

DIRECT EXPANSION COMMERCIAL PACKAGED AIR HANDLING UNITS, 6 – 25 TONS

BUILT TO LAST, EASY TO INSTALL AND SERVICE

- Multi-position design for horizontal or vertical installation without modification.
- Two sloped condensate pans on each unit for horizontal or vertical applications.
- Cleanable insulation treated with Environmental Protection Agency (EPA) registered antimicrobial agent improves indoor air quality.
- 2 inch filters.
- High-static design meets a wide range of applications.
- Powerfull belt-driven forward curved fans.
- Single refrigerant circuit on 072 and 091 sizes. Dual refrigerant circuit on 120–300 sizes. Dual circuit can be field modified for use on single circuit condensers.
- Single blower on 6 to 10 ton units; dual blower on 12.5 to 25 ton units.
- Cooling coils with mechanically bonded fins provide peak heat transfer.
- Standard factory-installed thermo-static expansion valve (TXV) with removable power element.
- Easy maintenance – removal of single panel allows access to virtually all components.
- Die-formed galvanized steel casings provide durability and structural integrity. Optional paint is available.
- 24-volt terminal block for control wiring connection.
- Economizer accessory provides ventilation air and “free” cooling.
- Hot water coil, steam coil, and electric heat accessories are available.

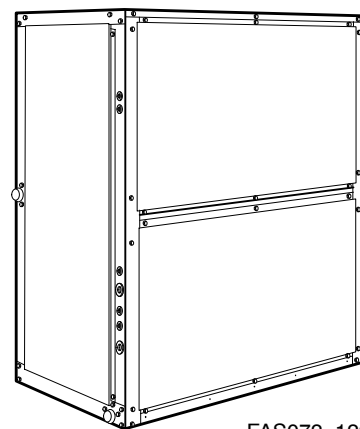

FAS072-120

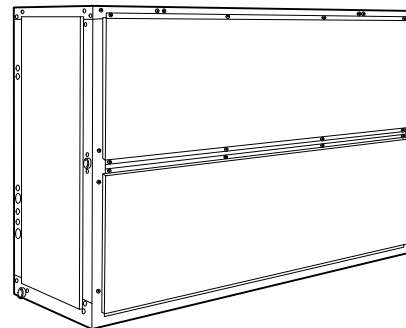

FAS150-300

WARRANTY

- 1 Year parts limited warranty



Use of the AHRI Certified TM Mark indicates a manufacturer's participation in the program. For verification of certification for individual products, go to www.ahrirectory.org.



UNIT PERFORMANCE DATA				
UNIT	Nominal Tons	Number of Circuits	Unit Dimensions H x W x L [mm]	Unit Weight lb. [kg]
FAS072*AAA0A0A	6	1	56-1/16" x 49" x 28-3/16" [1424 x 1244 x 714]	399 [181]
FAS091*AAA0A0A	7 1/2	1	56-1/16" x 49" x 28-3/16" [1424 x 1244 x 714]	404 [183]
FAS120*AAA0A0A	10	2	56-1/16" x 49" x 28-3/16" [1424 x 1244 x 714]	425 [193]
FAS150*AAA0A0A	12 1/2	2	56-1/16" x 89" x 28-3/16" [1424 x 2261 x 714]	695 [315]
FAS180*AAA0A0A	15	2	56-1/16" x 89" x 28-3/16" [1424 x 2261 x 714]	713 [323]
FAS240*AAA0A0A	20	2	56-1/16" x 89" x 28-3/16" [1424 x 2261 x 714]	730 [331]
FAS300*AAA0A0A	25	2	65-9/16" x 100-1/2" x 32-5/8" [1665 x 2553 x 829]	1050 [477]

* Indicates Unit voltage: K = 208/230-1-60, H = 208/230-3-60, M = 208/230/460-3-60, L = 460-3-60, S = 575-3-60

NOTE: BASE MODEL NUMBERS LISTED. SEE MODEL NOMENCLATURE LISTING FOR ADDITIONAL OPTIONS

TABLE OF CONTENTS

.....	PAGE
MODEL NUMBER NOMENCLATURE	3
OPTIONS AND ACCESSORIES	4
PHYSICAL DATA	7
DIMENSIONS	9
SELECTION PROCEDURE	22
PERFORMANCE DATA	23
ELECTRICAL DATA	35
TYPICAL PIPING AND WIRING	41
TYPICAL CONTROL WIRING SCHEMATIC	44
APPLICATION DATA	45
GUIDE SPECIFICATIONS	51

MODEL NOMENCLATURE

MODEL SERIES	F	A	S	0	9	1	M	A	A	A	0	A	0	A
Position Number	1	2	3	4	5	6	7	8	9	10	11	12	13	14
F = R-410A Fan Coil Unit														
A = Air Conditioning (Cooling Only) Type														
S = Standard Efficiency Efficiency														
072 = 6 Tons (1 circuit)														
091 = 7.5 Tons (1 circuit)														
120 = 10 Tons (2 circuit)														
150 = 12.5 Tons (2 circuit)														
180 = 15 Tons (2 circuit)														
240 = 20 Tons (2 circuit)														
300 = 25 Tons (2 circuit) Nominal Tonnage														
K = 208/230-1-60														
H = 208/230-3-60														
M = 460/208/230-3-60														
L = 460-3-60														
S = 575-3-60 Voltage														
A = Standard Static Standard Efficiency Motor / Standard Drive														
B = High Static Standard Efficiency Motor / High Drive														
D = Standard Static High Efficiency Motor / Standard Drive														
E = High Static High Efficiency Motor / High Drive Fan Motor Options														
A = Al/Cu Indoor Coil														
A = Standard D/X Coil Refrigerant System														
0 = No options Future Use														
A = None - Standard - Unpainted														
B = Painted cabinet (Gray) Painted Cabinet Options														
0 = Standard (Future use) Future Use														
A = Original Design Sales Digit														

*Single phase FAS072-091 units designate standard motor and high static drive.
 All FAS072-150 with a "M" voltage designation are triple voltage; i.e., 208/230/460-3-60.
 Size FAS180 is also triple voltage unless high static options is used, See chart below.

MODEL NUMBERS*	
Standard Static	High Static
FAS072KAAA0A0A	FAS072KBAA0A0A
FAS072MAAA0A0A	FAS072MBAA0A0A
FAS072SAAA0A0A	FAS072SBAA0A0A
FAS091KAAA0A0A	FAS091KBAA0A0A
FAS091MAAA0A0A	FAS091MBAA0A0A
FAS091SAAA0A0A	FAS091SBAA0A0A
FAS120MAAA0A0A	FAS120MBAA0A0A
FAS120SAAA0A0A	FAS120SBAA0A0A
FAS150MAAA0A0A	FAS150MBAA0A0A
FAS150SAAA0A0A	FAS150SEAA0A0A
FAS180MAAA0A0A	FAS180HEAA0A0A
FAS180SAAA0A0A	FAS180LEAA0A0A
-	FAS180SEAA0A0A
FAS240HDAA0A0A	FAS240HEAA0A0A
FAS240LDAA0A0A	FAS240LEAA0A0A
FAS240SDAA0A0A	FAS240SEAA0A0A
FAS300HDAA0A0A	FAS300HEAA0A0A
FAS300LDAA0A0A	FAS300LEAA0A0A
FAS300SDAA0A0A	FAS300SEAA0A0A

FACTORY OPTIONS AND/OR ACCESSORIES

Factory-installed accessories

Alternate fan motors and drives are available to provide the widest possible range of performance.

Prepainted steel units are available from the factory for applications that require painted units. Units are painted with American Sterling Gray color.

Field-installed accessories

Two-row hot water coils have copper tubes mechanically bonded to aluminum plate fins and non-ferrous headers.

One-row steam coil has copper tubes and aluminum fins. The Inner Distributing Tube (IDT) design provides uniform temperatures across the coil face. The steam coil has a broad operating pressure range; up to 20 psi (138 kPag) at 260°F (126°C). The IDT steam coils are especially suited to applications where sub-freezing air enters the unit.

Electric resistance heat coils have an open-wire design and are mounted in a rigid frame. Safety cutouts for high temperature conditions are standard. Terminal block for single-point power connection is included.

Economizer (enthalpy controlled) provides ventilation air and “free” cooling if outside ambient temperature and humidity are suitable. It can also be used with CO₂ sensors to help meet indoor air quality requirements.

Discharge plenum directs the air discharge directly into the occupied space; integral horizontal and vertical louvers enable redirection of airflow. Accessory is available unpainted or painted. Field assembly is required (only applicable for vertical application and cannot be used with electric heat).

Return-air grille provides a protective barrier over the return-air opening and gives a finished appearance to

units installed in the occupied space. Accessory is available unpainted or painted.

Subbase provides a stable, raised platform and room for condensate drain trap connection for vertical floor-mounted units. Accessory is available unpainted or painted.

Overhead suspension package includes necessary brackets to support units in horizontal ceiling installations.

CO₂ sensors can be used in conjunction with the economizer accessory to help meet indoor air quality requirements. The sensor signals the economizer to open when the CO₂ level in the space exceeds the set point. A programmable thermostat can be used to override the sensor if the outside-air temperature is too high or too low.

Condensate drain trap includes an overflow shutoff switch that can be wired to turn off the unit if the trap becomes plugged. Kit also includes a wire harness that can be connected to an alarm if desired. The transparent trap is designed for easy service and maintenance.

ITEM	OPTION*	ACCESSORY†
High Static Fan Motor / Drives	X	
CO ₂ Sensors		X
Condensate Drain Trap		X
Discharge Plenum		X
Economizer		X
Electric Heat		X
Hot Water Heating Coils		X
Overhead Suspension Package		X
Prepainted Units	X	
Return Air Grille		X
Steam Heating Coil		X
Subbase		X

* Factory-installed option.

† Field-installed accessory

ACCESSORIES		
Model Number	Description	Used on Unit Size (Tons)
AGRC01AA	Return Air Grille	6 to 10
AGRPC01AA	Return Air Grille, Painted	6 to 10
AGRC02BA	Return Air Grille	12-1/2 to 20
AGRPC02BA	Return Air Grille, Painted	12-1/2 to 20
ASPC01AA	Steam Coil (1 Row)	6 to 10 Ton
ASPC02BA	Steam Coil (1 Row)	12-1/2 to 20
ASBC01A	Floor Mount Base (Subbase)	6 to 20
ASBPC01A	Floor Mount Base (Subbase), Painted	6 to 20
ASBC01A	Overhead Suspension Brackets	6 to 25
ACSC01A	Condensate Overflow Switch	6 to 25
APDC01AA	Discharge Plenum	6 to 10
APDPC01AA	Discharge Plenum, Painted	6 to 10
APDC02BA	Discharge Plenum	12-1/2 to 20
APDPC02BA	Discharge Plenum, Painted	12-1/2 to 20
DNCBDIOX005A00	CO ₂ Sensor for Economizer	6 to 20
AEMC01AA	Economizer	6 to 10
AEMC02BA	Economizer	12-1/2 to 20
AHWC01AA	Hot Water Coil (2 Row)	6 to 10
AHWC02BA	Hot Water Coil (2 Row)	12-1/2 to 20

ACCESSORIES (CONT.)

Model Number	Description	Used on Unit Size (Tons)
CARAGRIL003A00	Return Air Grille	25
CARAGRIL006A00	Return Air Grille, Painted	25
CASTCOIL003A00	Steam Coil (1 Row)	25
CASUBASE002A00	Floor Mount Base (Subbase)	25
CASUBASE004A00	Floor Mount Base (Subbase), Painted	25
CAPLENUM003A00	Discharge Plenum	25
CAPLENUM006A00	Discharge Plenum, Painted	25
CAECOMZR003A00	Economizer	25
CAHWCOIL003A00	Hot Water Coil (2 Row)	25
CATRANRY001A00	Transformer Relay Package - Contains 200/230/460 to 24-volt transformer, indoor fan and solenoid valve relays with wiring and quick connect terminals. Recommended for 24-volt thermostat applications when additional VA is required.	6 to 25

ACCESSORY HEATERS

HEATER PART NO.	DESCRIPTION	Nominal Capacity	Used With
AAHC05AHA	5.0 kW, 240-3-60	5	072, 091, 120
AAHC10AHA	10.0 kW, 240-3-60	10	072, 091, 120
AAHC15AHA	15.0 kW, 240-3-60	15	072, 091, 120
AAHC25AHA	25.0 kW, 240-3-60	25	072, 091, 120
AAHC35CHA	35.0 kW, 240-3-60	35	091, 120
AAHC10BHA	10.0 kW, 240-3-60	10	150, 180, 240
AAHC20BHA	20.0 kW, 240-3-60	20	150, 180, 240
AAHC30BHA	30.0 kW, 240-3-60	30	150, 180, 240
AAHC50DHA	50.0 kW, 240-3-60	50	180, 240
AAHC20EHA	20.0 kW, 240-3-60	20	300
AAHC40EHA	40.0 kW, 240-3-60	40	300
AAHC50EHA	50.0 kW, 240-3-60	50	300
AAHC70EHA	70.0 kW, 240-3-60	70	300
AAHC05ALA	5.0 kW, 480-3-60	5	072, 091, 120
AAHC10ALA	10.0 kW, 480-3-60	10	072, 091, 120
AAHC15ALA	15.0 kW, 480-3-60	15	072, 091, 120
AAHC25ALA	25.0 kW, 480-3-60	25	072, 091, 120
AAHC35CLA	35.0 kW, 480-3-60	35	091, 120
AAHC10BLA	10.0 kW, 480-3-60	10	150, 180, 240
AAHC20BLA	20.0 kW, 480-3-60	20	150, 180, 240
AAHC30BLA	30.0 kW, 480-3-60	30	150, 180, 240
AAHC50DLA	50.0 kW, 480-3-60	50	180, 240
AAHC20ELA	20.0 kW, 480-3-60	20	300
AAHC40ELA	40.0 kW, 480-3-60	40	300
AAHC50ELA	50.0 kW, 480-3-60	50	300
AAHC70ELA	70.0 kW, 480-3-60	70	300
AAHC05ASA	5.0 kW, 575-3-60	5	072, 091, 120
AAHC10ASA	10.0 kW, 575-3-60	10	072, 091, 120
AAHC15ASA	15.0 kW, 575-3-60	15	072, 091, 120
AAHC25ASA	25.0 kW, 575-3-60	25	072, 091, 120
AAHC35CSA	35.0 kW, 575-3-60	35	091, 120
AAHC10BSA	10.0 kW, 575-3-60	10	150, 180, 240
AAHC20BSA	20.0 kW, 575-3-60	20	150, 180, 240
AAHC30BSA	30.0 kW, 575-3-60	30	150, 180, 240
AAHC50DSA	50.0 kW, 575-3-60	50	180, 240
AAHC20ESA	20.0 kW, 575-3-60	20	300
AAHC40ESA	40.0 kW, 575-3-60	40	300
AAHC50ESA	50.0 kW, 575-3-60	50	300
AAHC70ESA	70.0 kW, 480-3-60	70	300

FAS WITH DISCHARGE PLENUM, RETURN AIR GRILLE AND SUBBASE

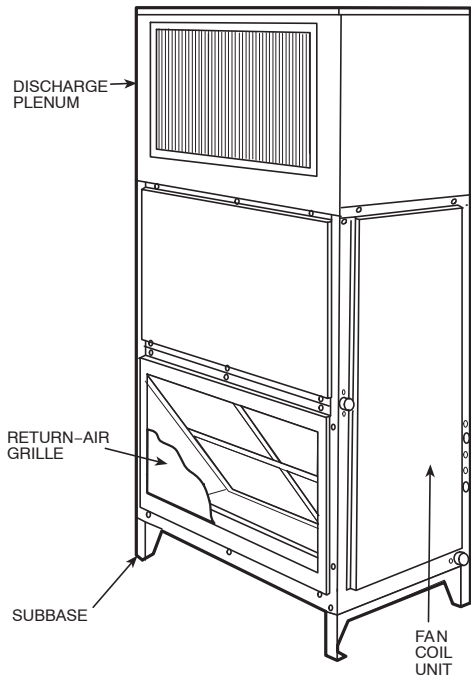

FAS WITH HOT WATER OR STEAM COIL

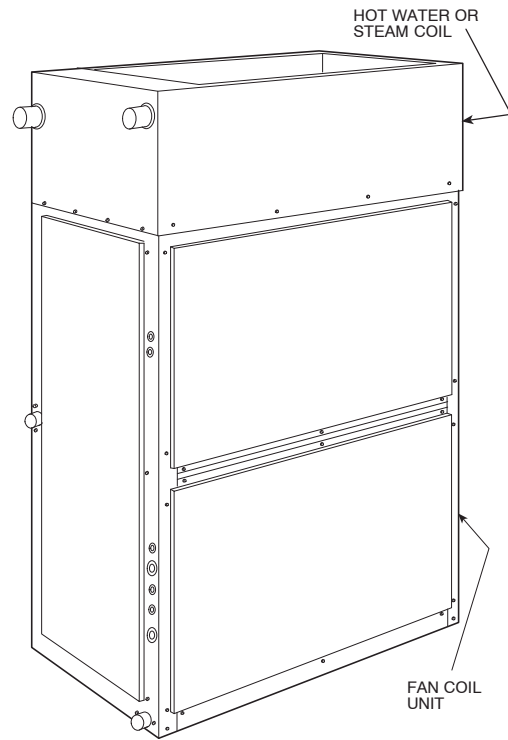

FAS WITH ECONOMIZER

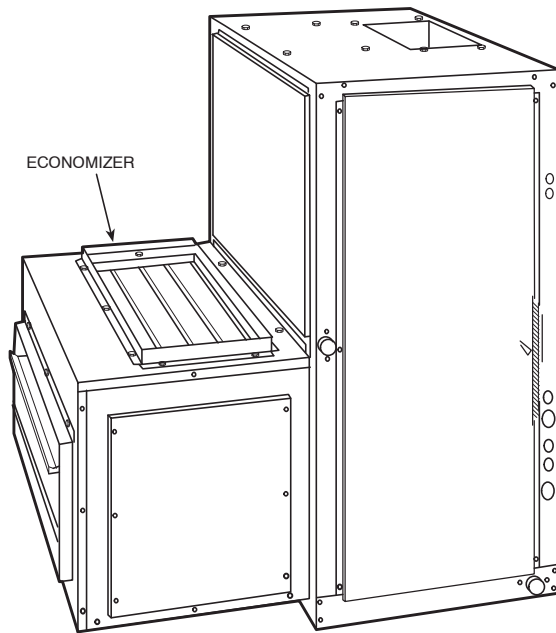

FAS WITH CONDENSATE TRAP

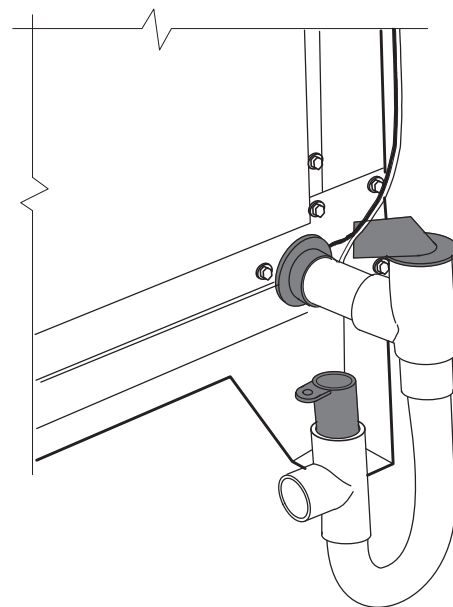

Physical Data, English – Cooling Units

UNIT FAS	072	091	120	150	180	240	300	
NOMINAL CAPACITY (Tons)	6	7 ¹ / ₂	10	12 ¹ / ₂	15	20	25	
OPERATING WEIGHT (lb)								
Base Unit with TXV (4 Row)	399	404	425	695	713	730	1050	
Plenum	175	175	175	225	225	225	325	
Economizer	185	185	185	340	340	340	340	
Hot Water Coil	195	195	195	285	285	285	345	
Steam Coil	215	215	215	340	340	340	405	
FANS								
Qty...Diam. (in.)	1...15	1...15	1...15	2...15	2...15	2...15	2...18	
Nominal Airflow (cfm)	2400	3000	4000	5000	6000	8000	10,000	
Airflow Range (cfm)	1800-3000	2250-3750	3000-5000	3750-6250	4500-7500	6000-10,000	7500-12,500	
Nom. Motor Hp (Standard Motor)*								
208/230-1-60	1.3	2.4	—	—	—	—	—	
208/230-3-60 and 460-3-60	2.4	2.4	2.4	2.9	3.7	5.0	7.5	
575-3-60	1.0	2.0	2.0	3.0	3.0	5.0	7.5	
230-3-50, 400-3-50	2.4	2.4	2.9	2.9	2.9	5.0	7.5	
Motor Speed (rpm)								
208/230-1-60	1725	1725	—	—	—	—	—	
208/230-3-60 and 460-3-60	1725	1725	1725	1725	1725	1745	1745	
575-3-60	1725	1725	1725	1725	1725	1745	1755	
230-3-50, 400-3-50	1425							
REFRIGERANT	R-410A							
Operating charge (lb) (approx per circuit) †	3.0	3.0	1.5/1.5	2.0/2.0	2.5/2.5	3.5/3.5	4.5/4.5	
DIRECT-EXPANSION COIL	Enhanced Copper Tubes, Aluminum Sine-Wave Fins							
Max Working Pressure (psig)	435							
Face Area (sq ft)	6.67	8.33	10.01	13.25	17.67	19.88	24.86	
No. of Splits	1	1	2	2	2	2	2	
Split Type...Percentage	Face...50/50							
No. of Circuits per Split	12	15	9	12	16	18	20	
Fins/in.	15	15	17	15	15	17	15	
STEAM COIL								
Max Working Press. (psig at 260°F)	20							
Total Face Area (sq ft)	6.67	6.67	6.67	13.33	13.33	13.33	15.0	
Rows...Fins/in.	1...9	1...9	1...9	1...10	1...10	1...10	1...10	
HOT WATER COIL								
Max Working Pressure (psig)	150							
Total Face Area (sq ft)	6.67	6.67	6.67	13.33	13.33	13.33	15.0	
Rows...Fins/in.	2...8.5	2...8.5	2...8.5	2...8.5	2...8.5	2...8.5	2...12.5	
Water Volume								
(gal)	8.3						13.9	14.3
(ft ³)	1.1						1.85	1.90
PIPING CONNECTIONS**								
Quantity...Size (in.)								
DX Coil — Suction (ODF)	1...1 ¹ / ₈					2...1 ¹ / ₈		2...1 ³ / ₈
DX Coil — Liquid Refrig. (ODF)	1...5 ⁵ / ₈					2...5 ⁵ / ₈		
Steam Coil, In (MPT)				1...2 ¹ / ₂				
Steam Coil, Out (MPT)				1...1 ¹ / ₂				
Hot Water Coil, In (MPT)	1...1 ¹ / ₂						1...2	
Hot Water Coil, Out (MPT)	1...1 ¹ / ₂						1...2	
Condensate (PVC)	1...5/8 ODM/1 IDF							
FILTERS	Throwaway — Factory-Supplied							
Quantity...Size (in.)	4...16 x 24 x 2			4...16 x 20 x 2			4...20 x 24 x 2	
Access Location				4...16 x 24 x 2			4...20 x 25 x 2	
	Right or Left Side							

* Refer to Alternate Fan Motor Data table, page 36, for alternate motor data.

† Units are shipped without refrigerant charge.

** All piping sizes are OD inches; equivalent sizes in millimeters follow:

Physical Data, SI – Cooling Units							
UNIT FAS	072	091	120	150	180	240	300
NOMINAL CAPACITY (kW)	21	26	35	43	52	70	87
OPERATING WEIGHT (kg)							
Base Unit with TXV (4 Row)	181	183	193	315	323	331	470
Plenum	80	80	80	102	102	102	148
Economizer	84	84	84	155	155	155	205
Hot Water Coil	89	89	89	130	130	130	157
Steam Coil	98	98	98	155	155	155	184
FANS							
Qty...Diam. (mm)	1...381	1...381	1...381	2...381	2...381	2...381	2...457
Nominal Airflow (L/s)	1133	1604	1888	2360	2831	3775	4719
Airflow Range (L/s)	850-1416	1203-2006	1416-2360	1770-2949	2124-3539	2831-4719	3539-5899
Nominal Motor kW (Standard Motor)*							
208/230-1-60	0.97	1.79	—	—	—	—	—
208/230-3-60 and 460-3-60	1.79	1.79	1.79	2.16	2.76	3.73	5.59
575-3-60	0.75	1.49	1.49	2.24	2.24	3.73	5.59
230-3-50, 400-3-50	1.79	1.79	2.16	2.16	2.16	3.73	5.59
Motor Speed (r/s)							
208/230-1-60	28.8	28.8	—	—	—	—	—
208/230-3-60 and 460-3-60	28.8	28.8	28.8	28.8	28.8	29.1	29.1
575-3-60	28.8	28.8	28.8	28.8	28.8	29.1	29.3
230-3-50, 400-3-50	23.8	23.8	23.8	23.8	23.8	23.8	23.8
REFRIGERANT	R-410A						
Operating charge (kg)							
(approx per circuit) †	1.36	1.36	0.68/0.68	0.90/0.90	1.13/1.13	1.59/1.59	2.04/2.04
DIRECT-EXPANSION COIL	Enhanced Copper Tubes, Aluminum Sine-Wave Fins						
Max Working Pressure (kPag)	2999						
Face Area (sq m)	0.62	0.77	0.93	1.23	1.64	1.85	2.30
No. of Splits	1	1	2	2	2	2	2
No. of Circuits per Split (4 Row)	12	15		12	16	18	20
Split Type...Percentage	—	—			Face...50/50		
Fins/m	591	591	670	591	591	670	591
STEAM COIL							
Max Working Pressure (kPag at 126°C)	138						
Total Face Area (sq m)	0.62	0.62	0.62	1.24	1.24	1.24	1.39
Rows...Fins/m	1...355	1...355	1...355	1...394	1...394	1...394	1...394
HOT WATER COIL							
Max Working Pressure (kPag)	1034						
Total Face Area (sq m)	0.62	0.62	0.62	1.24	1.24	1.24	1.39
Rows...Fins/m	2...335	2...335	2...335	2...335	2...335	2...335	2...493
Water Volume							
(L)		31.4			52.6		54.1
(m ³)		0.031			0.052		0.054
PIPING CONNECTIONS**							
Quantity...Size (in.)							
DX Coil — Suction (ODF)	1...1 ¹ / ₈	1...1 ¹ / ₈	2...1 ¹ / ₈	2...1 ¹ / ₈	2...1 ¹ / ₈	2...1 ¹ / ₈	2...1 ³ / ₈
DX Coil — Liquid Refrigerant (ODF)		1... ⁵ / ₈			2... ⁵ / ₈		
Steam Coil, In (MPT)		1...2 ¹ / ₂			1...2 ¹ / ₂		
Steam Coil, Out (MPT)		1...1 ¹ / ₂			1...1 ¹ / ₂		
Hot Water Coil, In (MPT)		1...1 ¹ / ₂	1...1 ¹ / ₂			1...2	
Hot Water Coil, Out (MPT)		1...1 ¹ / ₂	1...1 ¹ / ₂			1...2	
Condensate (PVC)	1...5/8 ODM/1 IDF						
FILTERS	Throwaway — Factory-Supplied						
Quantity...Size	4...406 x 610 x 51			4...406 x 508 x 51		4...508x610x51	
Access Location				4...406 x 610 x 51		4...508x635x51	
	Right or Left Side						

* Refer to Alternate Fan Motor Data table, page 36, for alternate motor data.

† Units are shipped without refrigerant charge.

** All piping sizes are OD inches; equivalent sizes in millimeters follow:

Dimensions - Sizes 6 - 10 Ton

LEGEND

TXV - Thermostatic Expansion Valve

NOTES:

1. Dimensions in [mm]
2. Direction of airflow
3. Recommended clearance:
Rear: 3 in [76 mm]
Front: 2 ft, 6 in [762 mm]
Right side: 2 ft, 6 in [762 mm]
Left side: 2 ft, 6 in [762 mm]
Local codes or jurisdiction may prevail
4. Liquid piping not supplied
5. Duct flange is factory supplied and field installed.

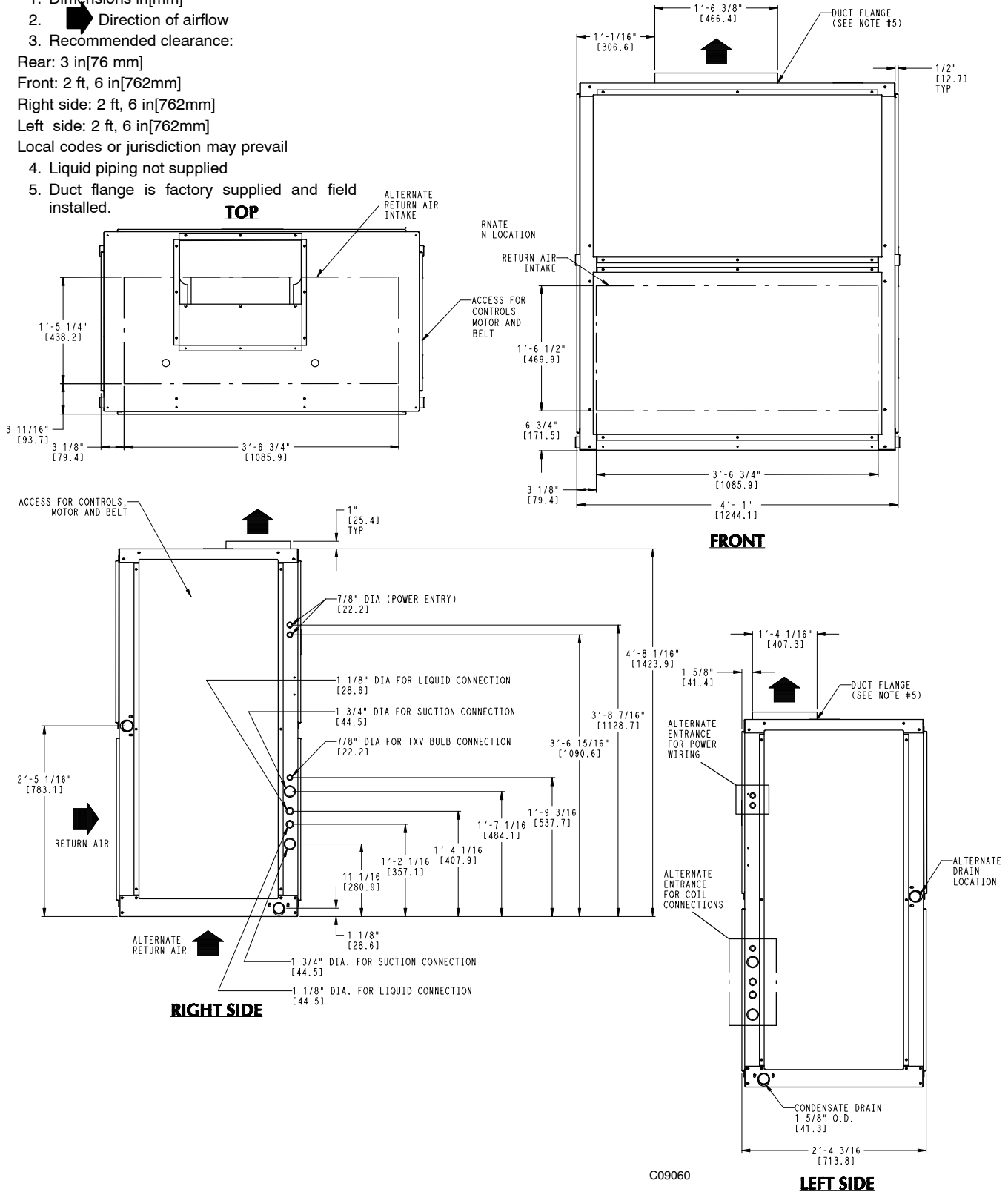

UNIT	UNIT WEIGHT lb(kg)
FAS072	399 (181)
FAS091	404 (183)
FAS120	425 (193)

Dimensions – Sizes 12.5 to 20 Ton

LEGEND

TXV – Thermostatic Expansion Valve

NOTES:

1. Dimensions in [mm]
2.  Direction of airflow
3. Recommended clearance:
Rear: 3 in [76 mm]
Front: 2 ft, 6 in [762mm]
Right side: 2 ft, 6 in [762mm]
Left side: 2 ft, 6 in [762mm]
Local codes or jurisdiction may prevail
4. Liquid piping not supplied
5. Duct flange is factory supplied and field installed.

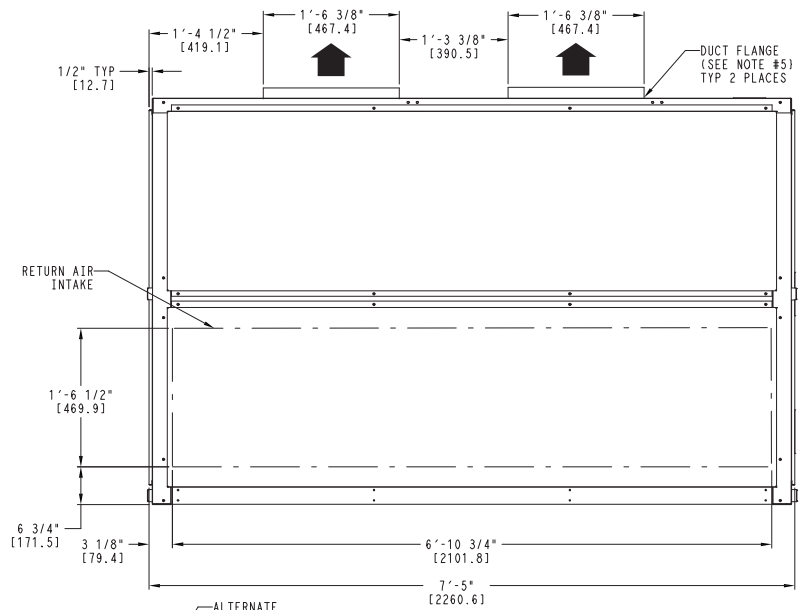

TOP

FRONT

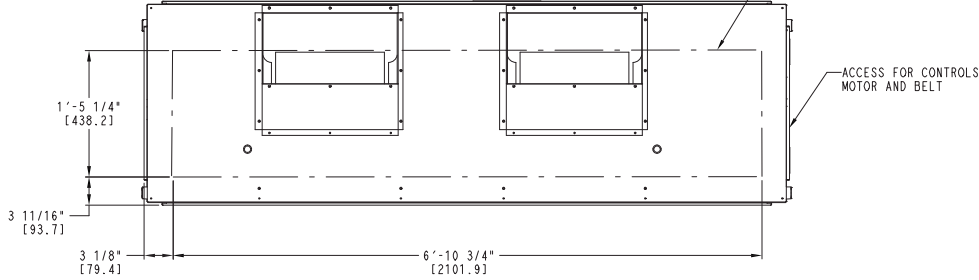

LEFT SIDE

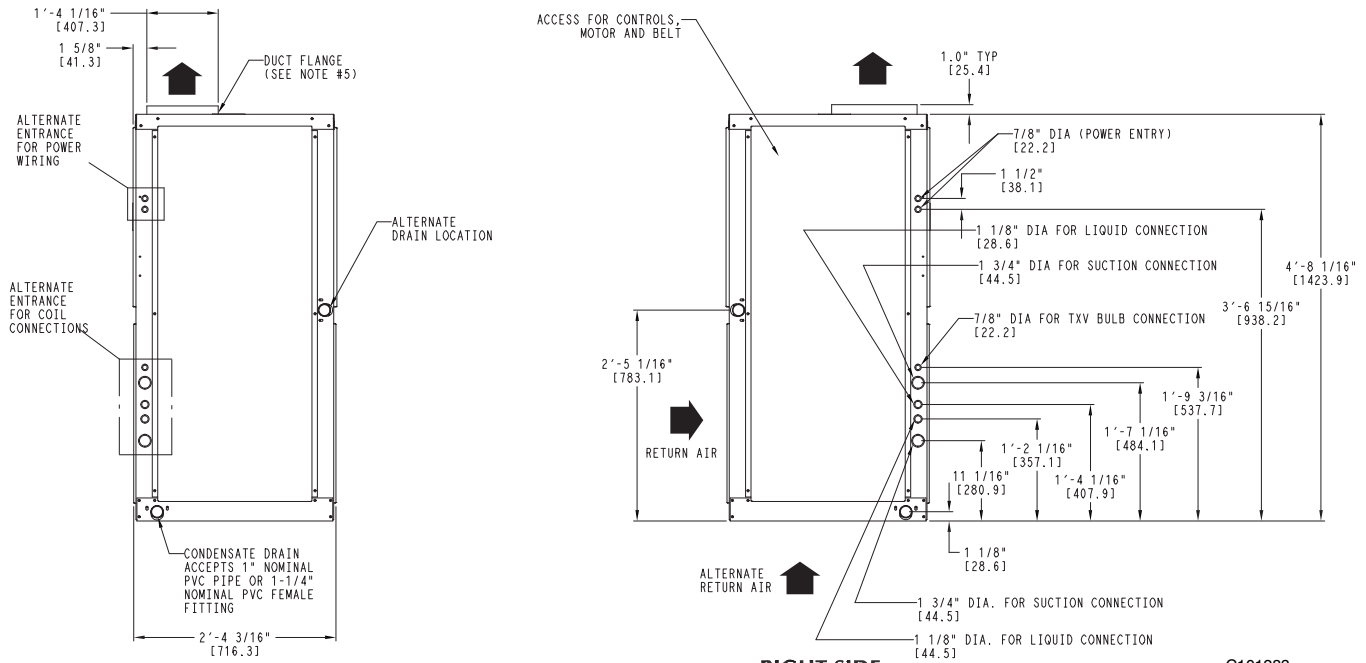

RIGHT SIDE

C101283

UNIT	UNIT WEIGHT lb(kg)
FAS150	695 (315)
FAS180	713 (323)
FAS240	730 (331)

Dimensions - Size 25 Ton

NOTES:

1. DIMENSIONS IN [] ARE IN MILLIMETERS.
2.  DIRECTIONS OF AIRFLOW.
3. RECOMMENDED CLEARANCE:
 REAR: 3 in. [76 mm]
 FRONT: 2 ft 6 in. [762 mm]
 RIGHT SIDE: 2 ft 6 in [762 mm]
 LEFT SIDE: 2 ft 6 in [762 mm]
 LOCAL CODES OR JURISDICTION MAY PREVAIL.
4. LIQUID PIPING NOT SUPPLIED
5. DUCT FLANGE IS FACTORY SUPPLIED AND FIELD INSTALLED.

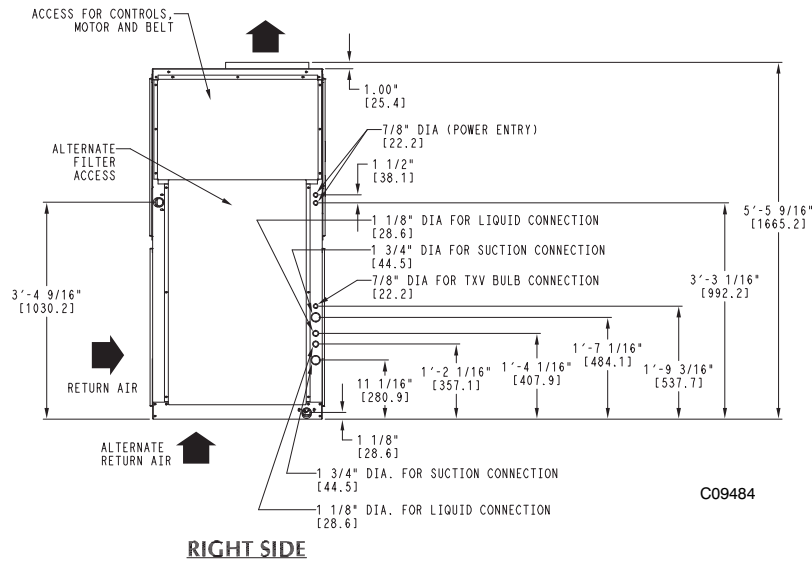
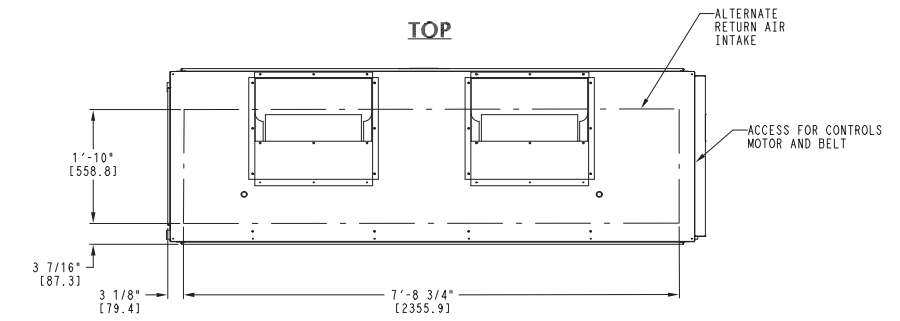
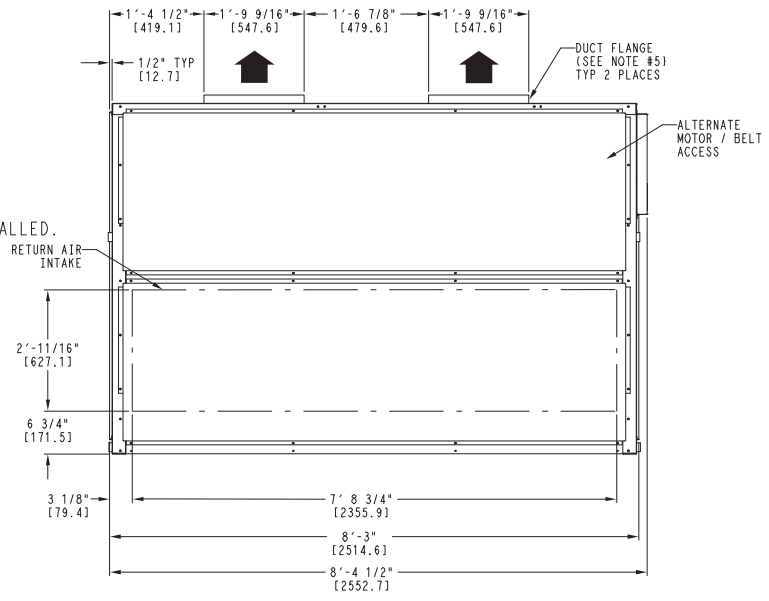
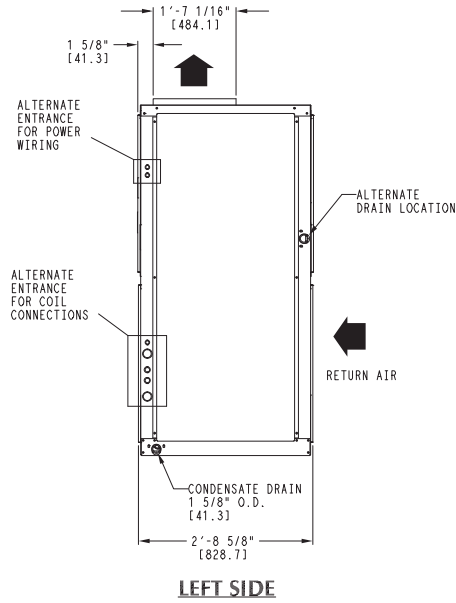

UNIT	UNIT WEIGHT lb(kg)
FAS300	1050 (477)

CORNER WEIGHTS
HORIZONTAL POSITION

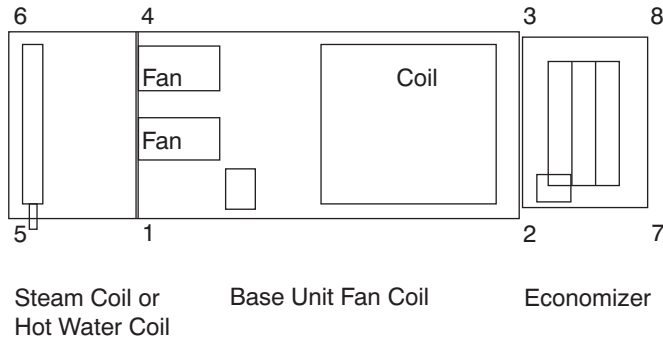

FAS – U.S.

FAS UNIT SIZE	UNIT OR ACCESSORY NAME		UNIT OR ACCESSORY WEIGHT (lb)	CORNER NUMBER (WEIGHT IN LB)							
				1	2	3	4	5	6	7	8
FAS072	FAN COIL BASE UNIT		399	109.3	106.1	90.6	93.4	—	—	—	—
FAS091	FAN COIL BASE UNIT		404	110.7	107.5	91.7	94.5	—	—	—	—
FAS120	FAN COIL BASE UNIT		425	116.4	113.0	96.5	99.4	—	—	—	—
FAS 072, 091, 120	STEAM COIL	ADD	215	40.2	0.0	0.0	40.6	66.5	67.5	0.0	0.0
	HOT WATER COIL	ADD	195	35.9	0.0	0.0	36.7	60.4	62.0	0.0	0.0
	ECONOMIZER	ADD	185	0.0	36.8	35.7	0.0	0.0	0.0	56.8	55.1
	ECO + STEAM COIL	ADD	400	38.8	38.6	37.4	39.2	64.2	65.2	59.5	57.7
	ECO + HW COIL	ADD	380	36.9	35.8	34.6	37.7	62.1	63.8	55.1	53.4
FAS150	FAN COIL BASE UNIT		695	224.0	177.7	129.8	163.7	—	—	—	—
FAS180	FAN COIL BASE UNIT		713	229.8	182.3	133.2	167.9	—	—	—	—
FAS240	FAN COIL BASE UNIT		730	235.6	186.4	136.5	171.5	—	—	—	—
FAS 150, 180, 240	STEAM COIL	ADD	340	61.4	0.0	0.0	62.0	107.8	108.8	0.0	0.0
	HOT WATER COIL	ADD	285	51.7	0.0	0.0	51.3	91.5	90.6	0.0	0.0
	ECONOMIZER	ADD	340	0.0	66.9	62.0	0.0	0.0	0.0	109.8	102.0
	ECO + STEAM COIL	ADD	680	64.4	63.7	59.0	65.0	113.0	114.1	104.5	97.1
	ECO + HW COIL	ADD	625	60.0	57.6	53.4	59.5	106.2	105.1	94.6	87.8
FAS300	FAN COIL BASE UNIT		1050	338.4	268.5	196.1	247.2	—	—	—	—
FAS300	STEAM COIL	ADD	405	73.2	0.0	0.0	73.8	128.4	129.6	0.0	0.0
	HOT WATER COIL	ADD	345	62.6	0.0	0.0	62.1	110.7	109.6	0.0	0.0
	ECONOMIZER	ADD	450	0.0	88.5	82.0	0.0	0.0	0.0	145.3	134.2
	ECO + STEAM COIL	ADD	855	80.6	80.1	74.1	81.6	142.0	143.4	131.3	122
	ECO + HW COIL	ADD	795	76.8	73.7	68.2	75.7	135.0	133.6	120.3	111.7

FAS – SI

FAS UNIT SIZE	UNIT OR ACCESSORY NAME		UNIT OR ACCESSORY WEIGHT (kg)	CORNER NUMBER (WEIGHT IN KG)							
				1	2	3	4	5	6	7	8
FAS072	FAN COIL BASE UNIT		181	49.6	48.1	41.1	42.3	—	—	—	—
FAS091	FAN COIL BASE UNIT		183	50.1	48.6	41.5	42.8	—	—	—	—
FAS120	FAN COIL BASE UNIT		193	52.9	51.3	43.8	45.2	—	—	—	—
FAS 072, 091, 120	STEAM COIL	ADD	98	18.2	0.0	0.0	18.4	30.2	30.6	0.0	0.0
	HOT WATER COIL	ADD	89	16.4	0.0	0.0	16.7	27.5	28.2	0.0	0.0
	ECONOMIZER	ADD	84	0.0	16.7	16.2	0.0	0.0	0.0	25.8	25
	ECO + STEAM COIL	ADD	182	17.6	17.5	17.0	17.8	29.1	29.6	27.0	26.2
	ECO + HW COIL	ADD	173	16.8	16.3	15.8	17.2	28.3	29.0	25.1	24.3
FAS150	FAN COIL BASE UNIT		315	86.3	83.7	71.5	73.7	—	—	—	—
FAS180	FAN COIL BASE UNIT		323	88.5	85.9	73.3	75.6	—	—	—	—
FAS150, 180, 240	STEAM COIL	ADD	155	28.1	0.0	0.0	28.3	49.3	49.3	0.0	0.0
	HOT WATER COIL	ADD	130	23.6	0.0	0.0	23.4	41.8	41.2	0.0	0.0
	ECONOMIZER	ADD	155	0.0	30.2	28.3	0.0	0.0	0.0	50.3	46.2
	ECO + STEAM COIL	ADD	310	29.3	29.0	26.9	29.6	51.5	51.9	47.6	44.2
	ECO + HW COIL	ADD	285	27.5	26.4	24.4	27.1	48.5	47.9	43.1	40.1
FAS300	FAN COIL BASE UNIT		477	130.5	126.7	108.2	111.6	—	—	—	—
FAS300	STEAM COIL	ADD	184	33.4	0.0	0.0	33.6	58.5	58.5	0.0	0.0
	HOT WATER COIL	ADD	156	28.3	0.0	0.0	28.0	50.3	49.4	0.0	0.0
	ECONOMIZER	ADD	204	0.0	39.8	37.2	0.0	0.0	0.0	66.2	60.8
	ECO + STEAM COIL	ADD	387	36.5	36.4	33.5	36.9	64.4	64.8	59.4	55.1
	ECO + HW COIL	ADD	360	34.8	33.5	30.8	34.2	61.2	60.5	54.5	50.6

LEGEND:

ECO – Economizer

HW – Hot Water

**CORNER WEIGHTS
VERTICAL POSITION**

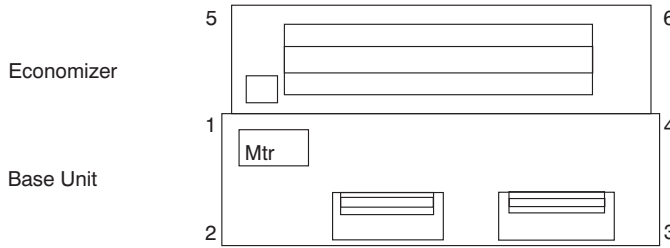

NOTE: Steam, Hot Water & Plenum
on top of positions 1,2,3,4

FAS – U.S.

FAS UNIT SIZE	UNIT OR ACCESSORY NAME		UNIT OR ACCESSORY WEIGHT (lb)	CORNER NUMBER (WEIGHT IN LB)					
				1	2	3	4	5	6
FAS072	FAN COIL BASE UNIT		399	100.5	114.9	98.0	85.8	—	—
FAS091	FAN COIL BASE UNIT		404	101.7	116.3	99.1	86.9	—	—
FAS120	FAN COIL BASE UNIT		425	107.6	122.3	108.0	87.1	—	—
FAS 072, 091, 120	STEAM COIL	ADD	215	54.1	54.1	53.4	53.4	0.0	0.0
	HOT WATER COIL	ADD	195	49.4	49.4	48.1	48.1	0.0	0.0
	PLENUM	ADD	175	50.8	36.7	36.7	50.8	0.0	0.0
	ECONOMIZER	ADD	195	38.9	0.0	0.0	37.1	59.9	58.3
	ECO + STEAM COIL	ADD	410	93.0	53.4	52.6	91.1	61.0	59.1
FAS150	FAN COIL BASE UNIT		695	191.2	210.5	153.8	139.5	—	—
FAS180	FAN COIL BASE UNIT		713	196.2	216.0	157.8	143.1	—	—
FAS150, 180	STEAM COIL	ADD	340	85.4	85.4	84.6	84.6	0.0	0.0
	HOT WATER COIL	ADD	285	70.9	70.9	71.6	71.6	0.0	0.0
	PLENUM	ADD	225	72.5	40.0	40.0	72.5	0.0	0.0
	ECONOMIZER	ADD	340	66.5	0.0	0.0	62.0	109.5	102.0
	ECO + STEAM COIL	ADD	680	153.0	89.1	88.7	147.7	104.5	97.0
FAS150, 180	ECO + HW COIL		625	139.9	82.5	83.3	136.7	94.7	87.9

FAS – SI

FAS UNIT SIZE	UNIT OR ACCESSORY NAME		UNIT OR ACCESSORY WEIGHT (kg)	CORNER NUMBER (WEIGHT IN LB)					
				1	2	3	4	5	6
FAS072	FAN COIL BASE UNIT		181	45.5	52.3	44.4	38.8	—	—
FAS091	FAN COIL BASE UNIT		183	46.0	52.7	44.9	39.4	—	—
FAS120	FAN COIL BASE UNIT		193	48.5	55.6	47.4	41.5	—	—
FAS 072, 091, 120	STEAM COIL	ADD	98	24.6	24.6	24.4	24.4	0.0	0.0
	HOT WATER COIL	ADD	89	22.4	22.4	22.1	22.1	0.0	0.0
	PLENUM	ADD	80	23.3	16.8	16.8	23.3	0.0	0.0
	ECONOMIZER	ADD	84	16.8	0.0	0.0	16.2	25.8	25.2
	ECO + STEAM COIL	ADD	182	41.3	23.6	23.3	40.3	27.0	26.5
FAS150	FAN COIL BASE UNIT		315	86.6	95.5	69.8	63.3	—	—
FAS180	FAN COIL BASE UNIT		323	88.9	97.9	71.6	64.9	—	—
FAS150, 180	STEAM COIL	ADD	155	39.0	39.0	38.5	38.5	0.0	0.0
	HOT WATER COIL	ADD	130	32.4	32.4	32.6	32.6	0.0	0.0
	PLENUM	ADD	102	32.9	18.1	18.1	32.9	0.0	0.0
	ECONOMIZER	ADD	155	31.1	0.0	0.0	28.5	49.7	45.7
	ECO + STEAM COIL	ADD	310	69.8	40.7	40.4	67.3	47.6	44.2
FAS150, 180	ECO + HW COIL		285	63.8	37.6	37.8	62.2	43.1	40.5

LEGEND:

ECO – Economizer
HW – Hot Water

Dimensions (cont.)

Preferred Suspension Technique – Overhead Suspension Accessory

**UNIT SIZES FAS072-120
(FRONT)**

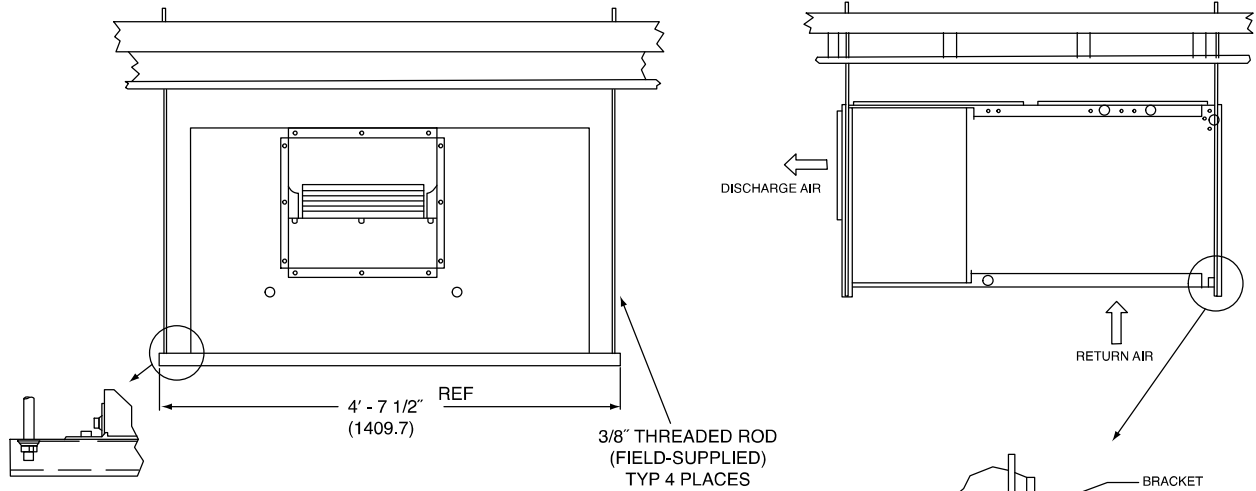

**UNIT SIZES FAS150-240
(FRONT)**

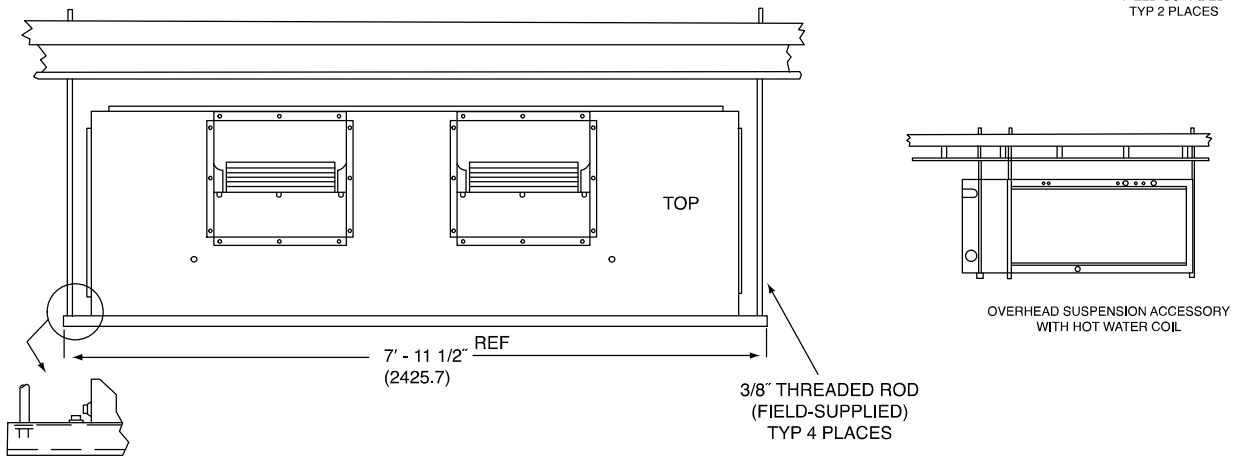

**UNIT SIZES FAS300
(FRONT)**

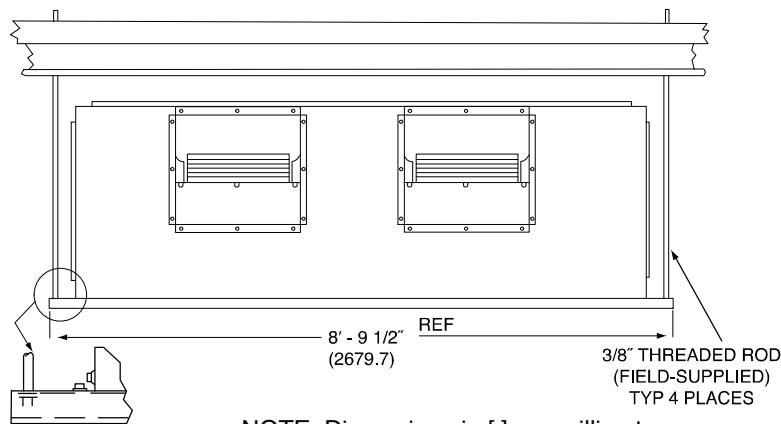

NOTE: Dimensions in [] are millimeters.

PLENUM, RETURN-AIR GRILLE, AND SUBBASE ACCESSORIES
UNIT SIZES 072 - 120

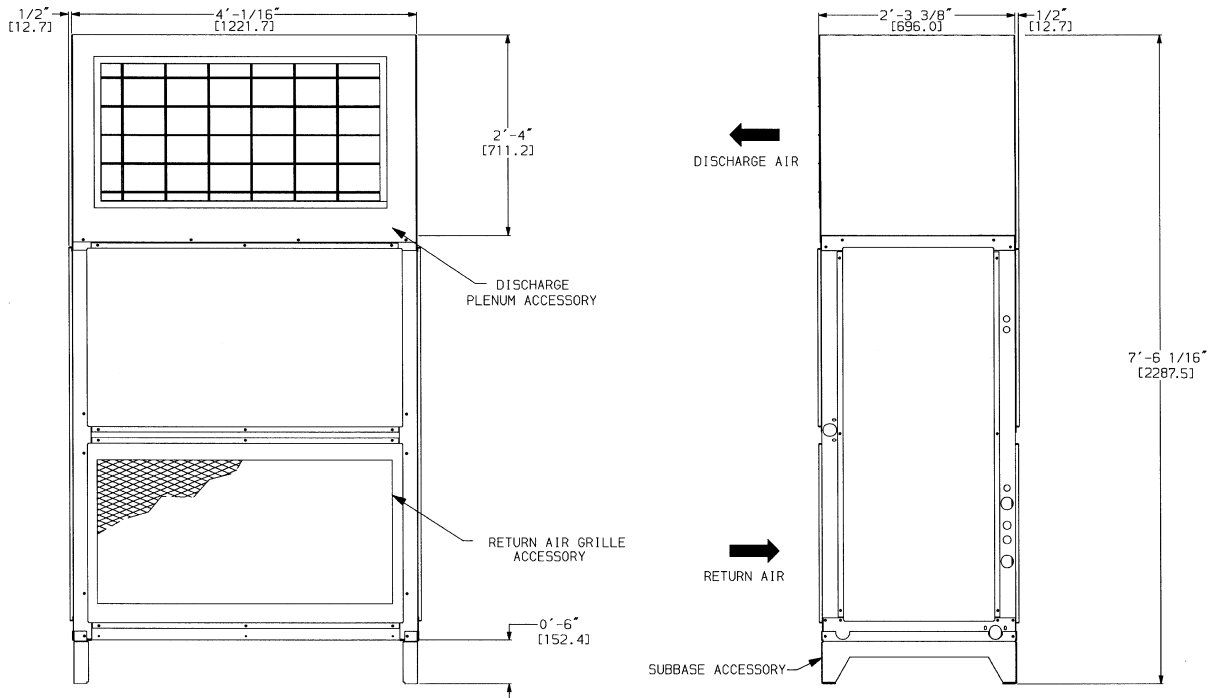

UNIT SIZE 150 - 240

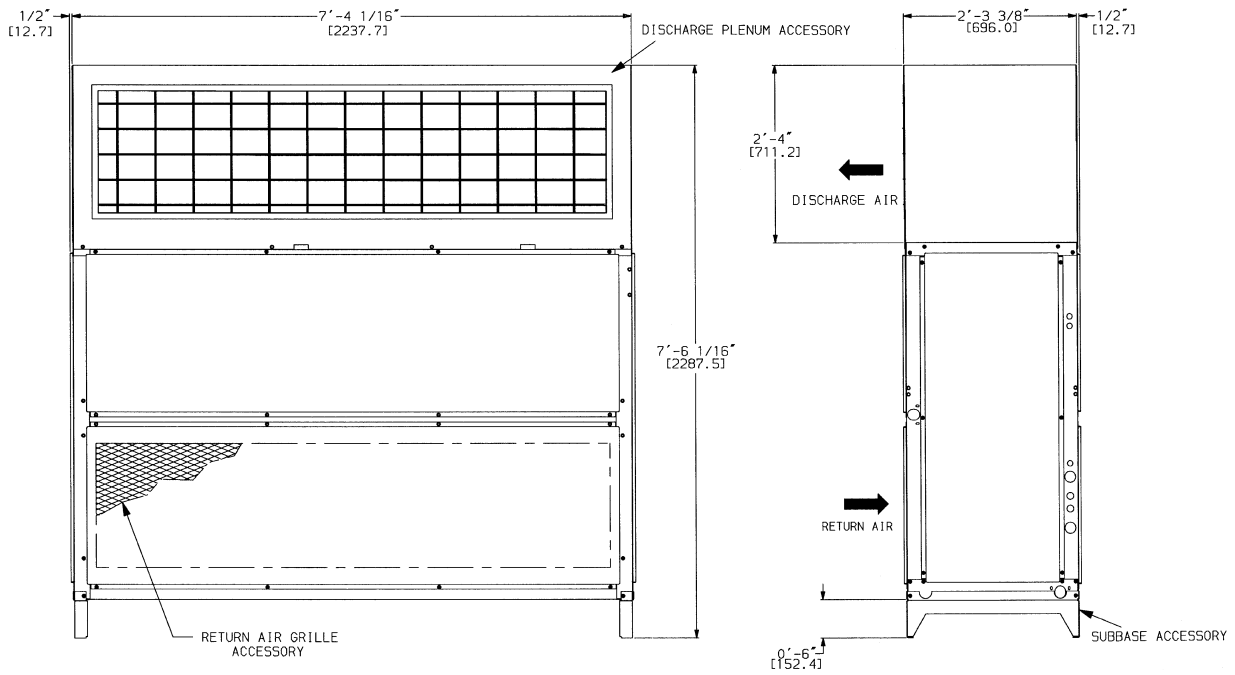

NOTE: Dimensions in [] are millimeters.

PLENUM, RETURN-AIR GRILLE, AND SUBBASE ACCESSORIES
UNIT SIZES FAS300

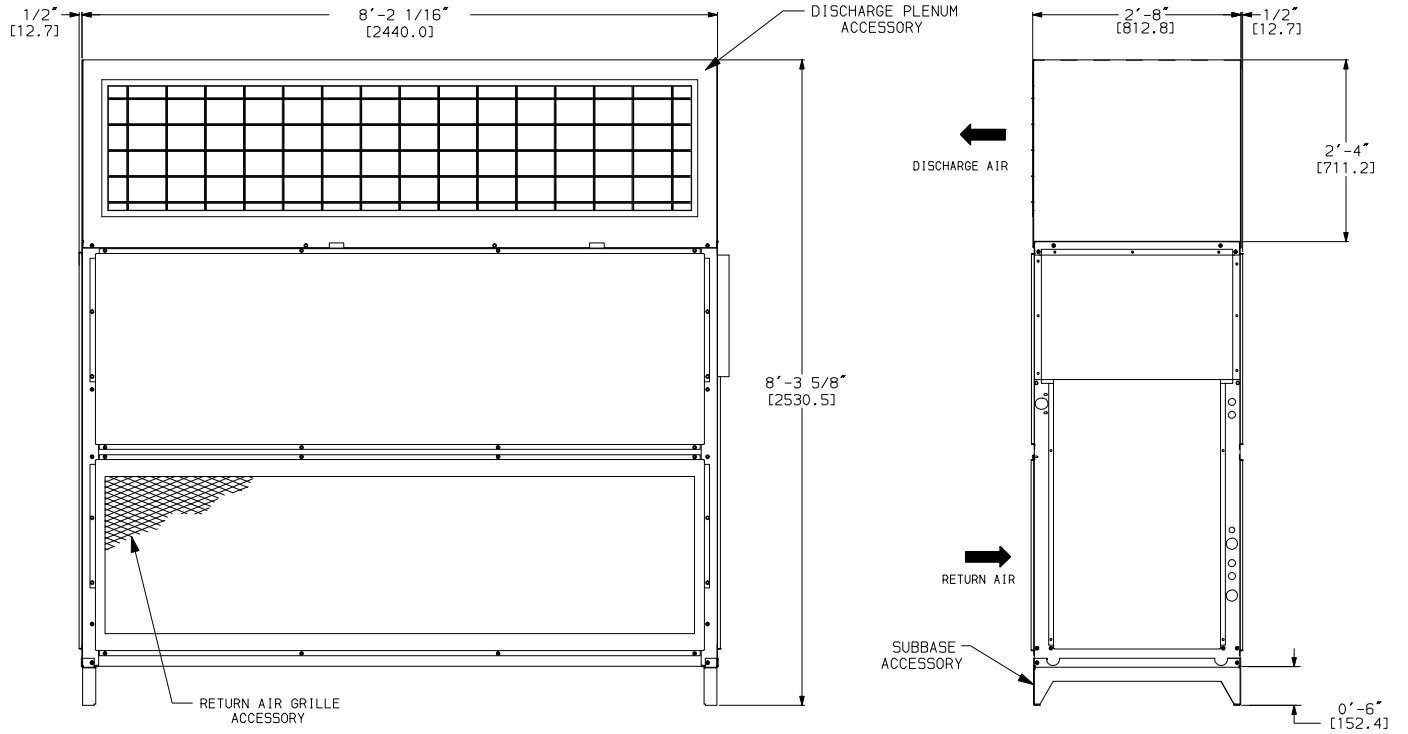

NOTE: Dimensions in [] are millimeters.

HOT WATER AND STEAM COIL ACCESSORIES

UNIT SIZES 072 – 120

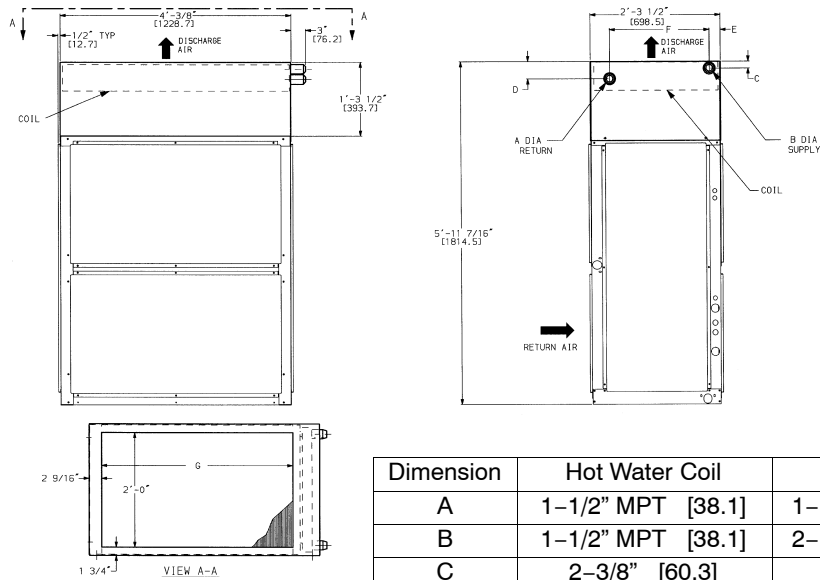

Dimension	Hot Water Coil	Steam Coil
A	1-1/2" MPT [38.1]	1-1/2" MPT [38.1]
B	1-1/2" MPT [38.1]	2-1/2" MPT [63.5]
C	2-3/8" [60.3]	3-1/8" [79.4]
D	4-7/8" [123.8]	3-1/8" [79.4]
E	2-1/8" [54.0]	4-9/16" [115.8]
F	1'-11 1/4" [590.6]	1' 9" [584.2]
G	3' 4" [1016.0]	3' 4" [1016.0]

UNIT SIZE 150 – 240

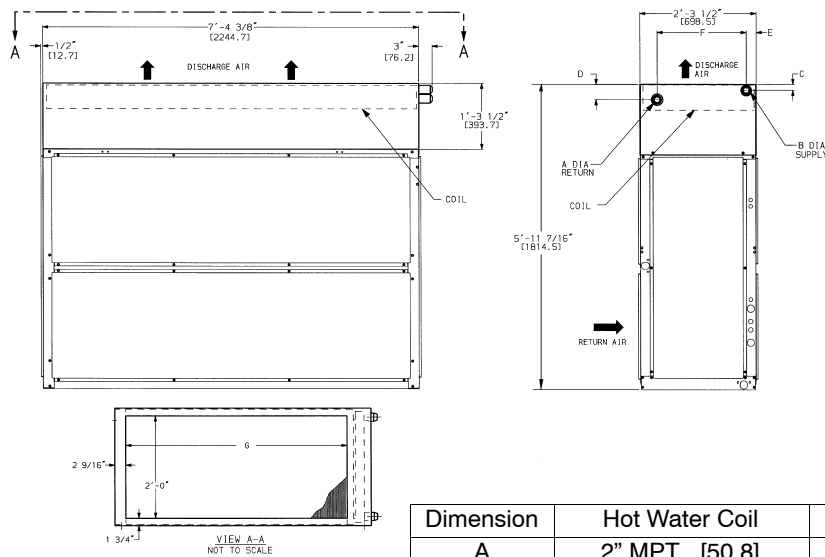

Dimension	Hot Water Coil	Steam Coil
A	2" MPT [50.8]	1-1/2" MPT [38.1]
B	2" MPT [50.8]	2-1/2" MPT [63.5]
C	2-3/8" [60.3]	3-1/8" [79.4]
D	4-7/8" [123.8]	3-1/8" [79.4]
E	2-1/8" [54.0]	4-9/16" [115.8]
F	1'-11 1/4" [590.6]	1' 9" [584.2]
G	6' 8" [2032.0]	6' 8" [2032.0]

NOTE: Dimensions in [] are millimeters.

HOT WATER AND STEAM COIL ACCESSORIES

UNIT SIZES 300

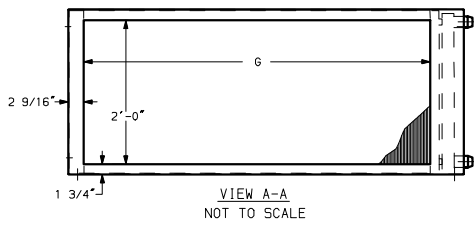
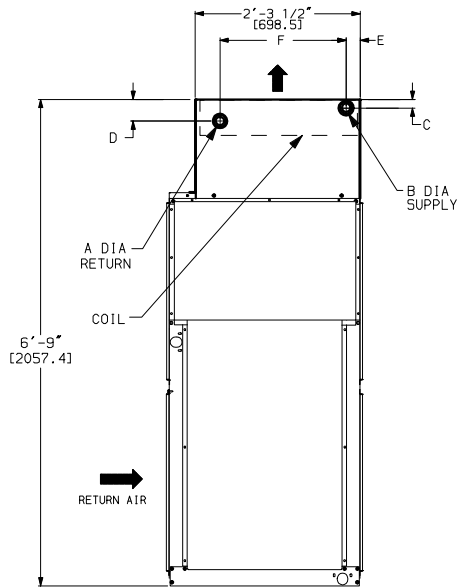
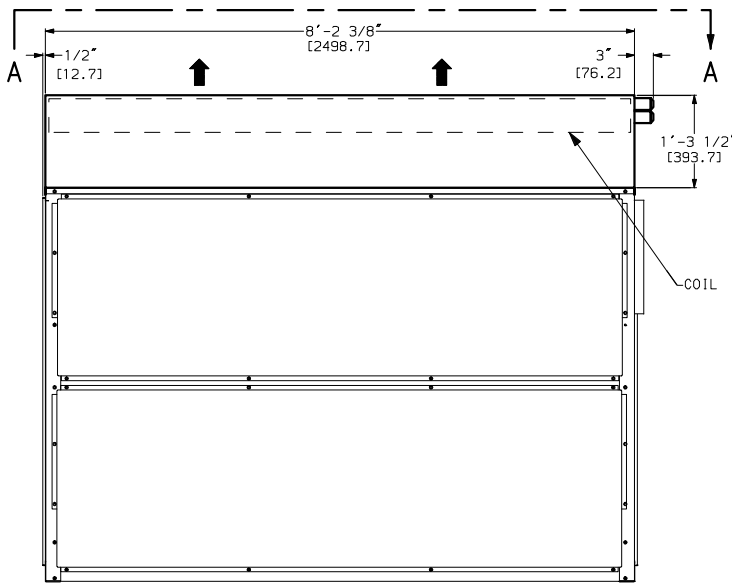

VIEW A-A
NOT TO SCALE

NOTE: Dimensions in [] are millimeters.

Dimension	Hot Water Coil	Steam Coil
A	2" MPT [50.8]	1-1/2" MPT [38.1]
B	2" MPT [50.8]	2-1/2" MPT [63.5]
C	2-3/8" [60.3]	3-1/8" [79.4]
D	4-7/8" [123.8]	3-1/8" [79.4]
E	2-1/8" [54.0]	4-9/16" [115.8]
F	1'-11 1/4" [590.6]	1' 9" [584.2]
G	7' 6" [2286.0]	7' 6" [2286.0]

ECONOMIZER ACCESSORY UNIT SIZES 072 – 120

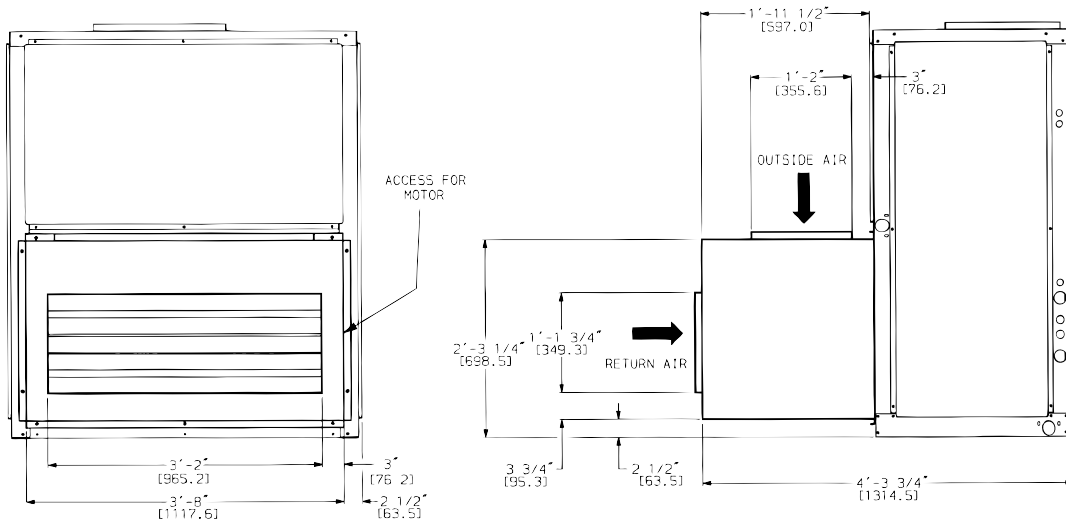

UNIT SIZES 150 – 240

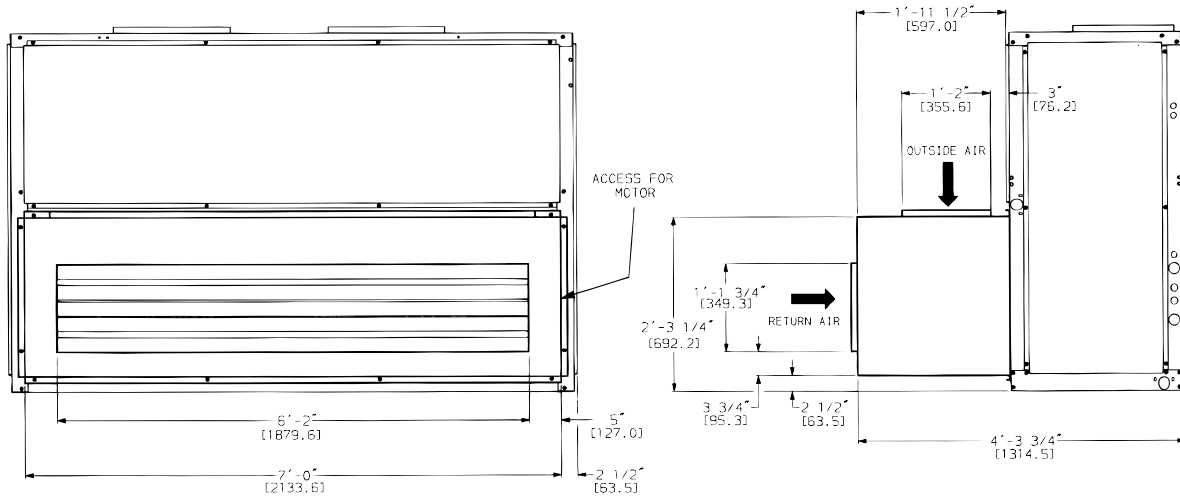

UNIT SIZES 300

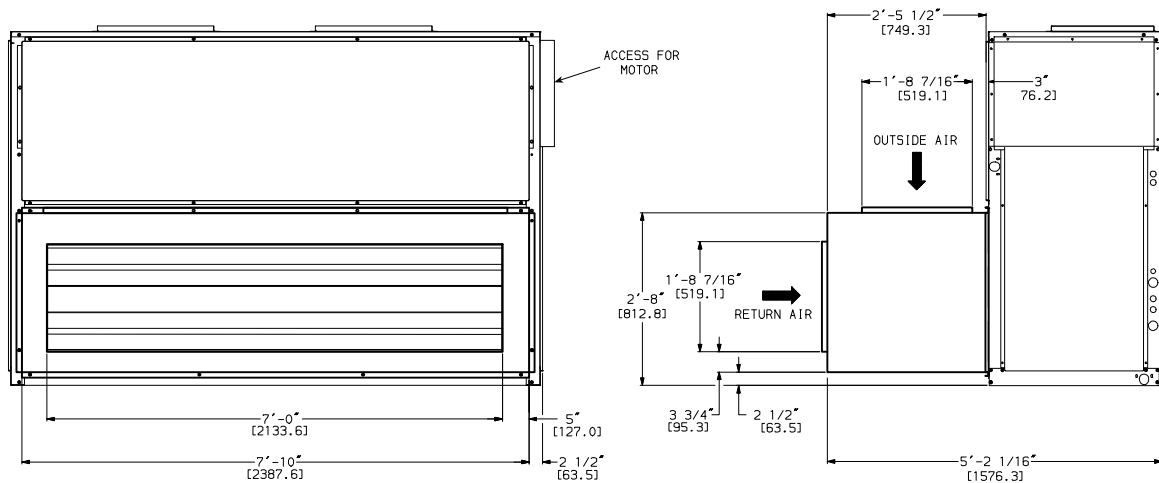

NOTE:

1. For horizontal unit applications, economizer can be attached to end of unit opposite duct connections.
2. Dimensions in [] are millimeters.

ELECTRIC HEAT ACCESSORY

UNIT SIZES 072 – 120

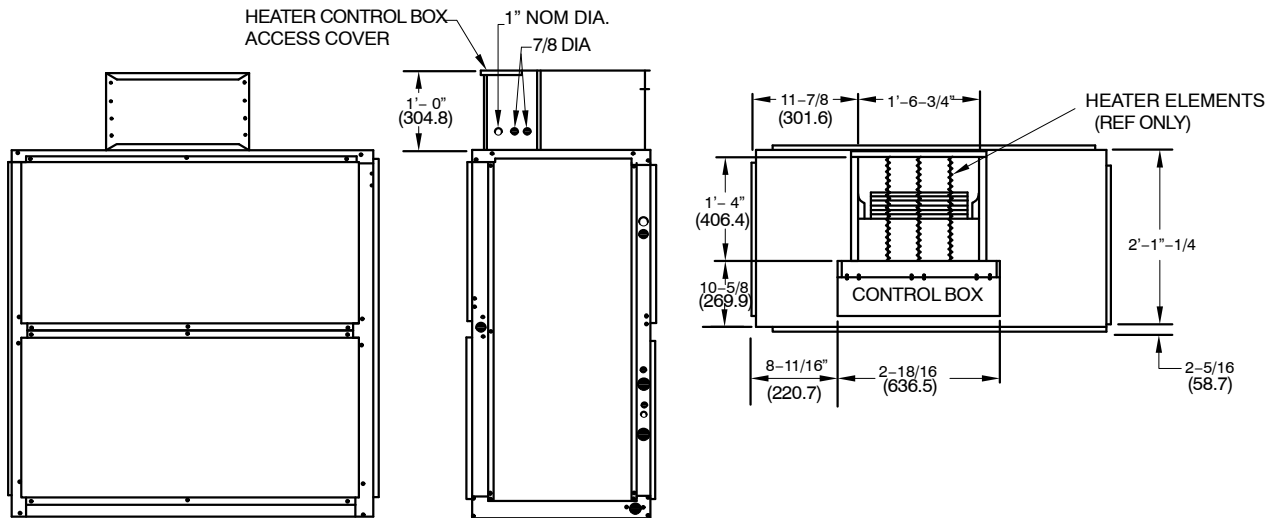

UNIT SIZES 150 – 300

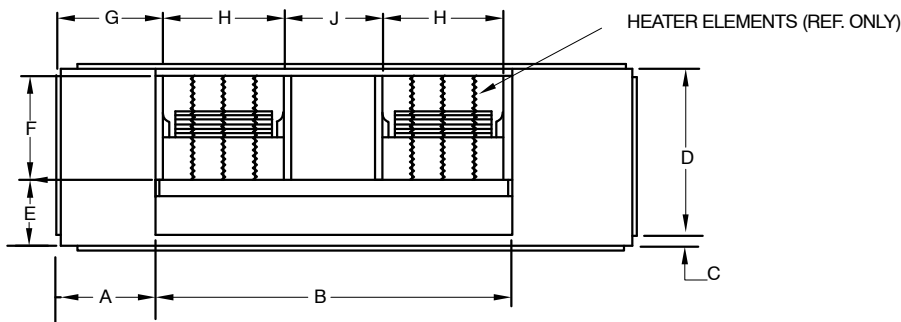
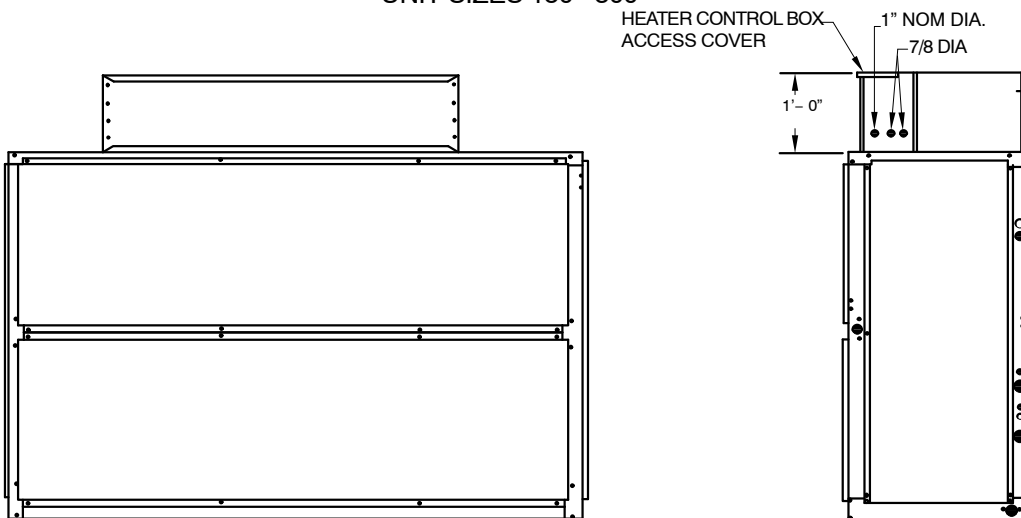

Unit Size	A	B	C	D	E	F	G	H	J
150-240	1'-3 1/4" [387.4]	4'-6 3/8" [1381.1]	2 5/16" [58.7]	2'-1 1/4" [641.4]	10 5/8" [269.9]	1'-4" [406.4]	1'-4 5/16" [414.3]	1'-6 3/4" [476.3]	1-7/8" [327.0]
300	1'-3 3/8" [390.5]	5'-4 7/8" [1636.8]	2 1/16" [26.9]	2'-6 3/16" [766.8]	1'-1 1/4" [311.2]	1'-7" [482.6]	1'-4 5/16" [414.3]	1'-10" [558.8]	1-4 7/16" [417.1]

SELECTION PROCEDURE (WITH EXAMPLE)

Cooling (DX)

I. Determine the cooling load and temperature and quantity of air entering the evaporator.

Given:

Total Capacity 200,000 Btuh
Sensible Heat Capacity 130,000 Btuh
Air Temperature Entering Indoor
Coil 80°F (27°C)db, 67°F (19°C) wb
Air Quantity Entering Indoor Coil 6000 cfm
Ductwork Static Pressure Loss 0.8 in. wg
Power Supply 230-3-60

II. Determine unit selection and coil refrigerant temperature.

Enter the Cooling Capacities table at 6000 cfm. Select a FAS180 unit which has a total capacity of 207,000 and 174,000 Btuh at 40 and 45°F (4 and 7°C) coil refrigerant temperature, respectively. By interpolation, coil refrigerant temperature of 41.1°F (5.1°C) is needed to give a total capacity of 200,000 Btuh. Sensible capacity is approximately 149,000 Btuh. Cooling load is satisfied.

Heating (Hot Water Coil)

I. Determine heating load and temperature of air entering the indoor coil.

Given:

Load 425,000 Btuh
Entering-Air Temperature 70°F (21°C)
Coils 2-Row Hot Water
Coil Entering-Water Temperature 200°F (93°C)
Water Temperature Drop 20°F (-7°C)

II. Find the heating capacity.

Enter Hydronic Heating Capacities table for the FAS180 unit at 6000 cfm. A 2-row hot water coil delivers 471,000 Btuh (based on 60°F/16°C entering air temperature and 20°F/-7°C water temperature drop). Since existing entering air temperature is 70°F (21°C), enter the Heating Correction Factors table for hot water coils at 200°F (93°C) entering water temperature, 20°F (-7°C) water temperature drop and 70°F (21°C) entering air. Read a constant of 0.93.

$$471,000 \times 0.93 = 438,000$$

The 438,000 Btuh rating satisfies the heating load.

Fan

I. Determine fan speed and brake horsepower:

From the Accessory Pressure Drop table, read a loss of 0.23 in. wg for a hot water coil at 6000 cfm.

$$\begin{aligned} \text{External static pressure} &= 0.80 + 0.23 \\ &= 1.03 \text{ in. wg} \end{aligned}$$

Enter FAS180 Fan Performance table at 6000 cfm and 1.03 in. wg. Interpolate and determine fan speed of 864 rpm and 3.1 bhp.

II. Determine motor and drive.

Enter the fan motor data tables and find that the 230 v standard motor for a FAS180 unit is rated at 3.7 Hp. Since the bhp required is 3.1, a standard motor satisfies the requirement and should be used.

Next, find the type of drive that satisfies the 864 rpm requirement in the Drive Data tables. For a FAS180 unit, the Medium-Static Drive table shows an rpm range of 742 to 943. Since the rpm required is 864, the medium-static drive satisfies the requirement and should be used. Select the standard motor and medium-static drive combination (option code "A" Standard or "B" High Static).

To select an outdoor unit for this FAS180 indoor section, refer to the Combination Rating sheets for CAS condensing units in the condensing unit Specification

PERFORMANCE DATA

FAS COOLING CAPACITIES – ENGLISH

UNIT FAS	EVAPORATOR AIR		COIL REFRIGERANT TEMP (°F)									
	Airflow (Cfm) BF	Ewb (°F)	30		35		40		45		50	
			TC	SHC	TC	SHC	TC	SHC	TC	SHC	TC	SHC
072	1,800 .06	72	124	60	113	55	101	49	87	43	71	37
		67	104	64	93	59	81	53	67	47	52	40
		62	86	68	75	62	63	56	49	49	42	42
	2,400 .10	72	143	69	131	64	117	58	101	52	83	44
		67	121	76	108	70	94	64	78	57	60	50
		62	101	83	88	76	73	69	60	60	51	51
3,000 .12	72	158	77	144	71	129	65	111	58	92	51	
	67	134	86	121	80	105	73	87	66	67	58	
	62	113	95	98	88	82	80	70	70	59	59	
091	2,250 .06	72	155	75	141	68	126	61	108	54	89	46
		67	130	80	116	73	101	66	83	59	64	51
		62	108	85	94	78	78	70	62	62	52	52
	3,000 .10	72	179	86	164	80	146	72	126	64	103	56
		67	151	95	136	88	118	80	98	71	75	62
		62	126	103	110	95	92	86	76	76	64	64
3,750 .12	72	197	96	180	89	161	82	139	73	115	63	
	67	168	108	151	100	131	92	109	82	84	72	
	62	141	119	122	110	103	100	87	87	74	74	
120	3,000 .05	72	200	96	182	88	161	79	138	70	113	60
		67	168	104	150	96	130	86	107	76	83	66
		62	140	112	121	102	101	92	82	82	69	69
	4,000 .07	72	228	111	208	102	185	93	159	83	130	71
		67	194	124	174	114	150	104	124	93	96	81
		62	162	135	141	124	119	113	99	99	84	84
5,000 .12	72	250	123	228	114	204	105	175	94	143	81	
	67	214	140	192	130	166	119	138	107	106	94	
	62	179	155	156	143	133	130	113	113	96	96	
150	3,750 .06	72	251	121	228	110	202	99	173	87	140	74
		67	210	129	187	118	161	106	133	94	102	81
		62	174	138	150	126	125	113	100	100	84	84
	5,000 .08	72	289	139	263	128	233	116	200	103	162	88
		67	244	154	218	141	188	128	155	114	119	99
		62	203	167	176	153	146	138	121	121	102	102
6,250 .10	72	319	155	290	143	258	131	221	116	180	101	
	67	271	174	242	161	209	147	172	132	133	115	
	62	226	192	196	177	164	160	139	139	118	118	
180	4,500 .03	72	310	150	281	136	249	122	214	108	174	92
		67	260	160	231	145	199	131	165	116	127	100
		62	215	169	186	154	154	138	121	121	102	102
	6,000 .05	72	361	175	329	161	292	145	250	128	205	110
		67	304	191	271	175	235	159	194	141	149	122
		62	254	206	220	189	183	170	149	149	125	125
7,500 .08	72	401	196	366	181	325	164	280	146	229	127	
	67	340	218	304	201	263	183	218	164	167	143	
	62	285	239	247	220	206	197	172	172	145	145	

LEGEND

BF — Bypass Factor
db — Dry-Bulb Temp (°F)
Ewb — Entering Wet-Bulb Temp (°F)
lwb — Leaving Wet-Bulb Temp (°F)
SHC — Sensible Heat Capacity (1000 Btuh)
TC — Total Capacity (1000 Btuh)

NOTES:

1. Ratings based on approximately 15°F superheat leaving coil.
2. Direct interpolation is permissible. Do not extrapolate.
3. Dashes indicate coil loading limits are exceeded.
4. Evaporator fan heat not deducted from ratings.

5. Formulas:

$$\text{Leaving db} = \text{entering db} - \frac{\text{sensible heat capacity (Btuh)}}{1.1 \times \text{cfm}}$$

$$\text{Leaving db} = \text{wet-bulb temperature corresponding to enthalpy of air leaving coil (h}_{lwb}\text{)}$$

$$h_{lwb} = h_{ewb} - \frac{\text{total capacity (Btuh)}}{4.5 \times \text{cfm}}$$

where h_{lwb} = enthalpy of air entering coil

6. SHC is based on 80°F db temperature of air entering evaporator coil.

PERFORMANCE DATA (CONT.)

FAS COOLING CAPACITIES – ENGLISH (cont.)

UNIT FAS	EVAPORATOR AIR		COIL REFRIGERANT TEMP (°F)									
	Airflow (Cfm) BF	Ewb (°F)	30		35		40		45		50	
			TC	SHC	TC	SHC	TC	SHC	TC	SHC	TC	SHC
240	6,000 .03	72	408	197	372	180	331	162	272	141	232	123
		67	344	213	307	195	266	176	220	156	169	135
		62	286	227	248	208	207	188	164	164	139	139
	8,000 .06	72	470	228	429	210	382	191	329	170	269	147
		67	399	253	357	233	309	212	256	189	197	166
		62	333	275	290	254	242	230	202	202	170	170
	10,000 .07	72	516	253	471	235	421	215	363	192	297	168
		67	440	287	395	266	343	244	284	219	220	193
		62	369	317	322	294	271	266	232	232	196	196
300	7,500 .04	72	470	226	428	208	379	187	328	167	270	144
		67	395	246	354	227	307	205	255	183	197	159
		62	329	265	287	244	240	221	193	193	163	163
	10,000 .06	72	535	260	487	240	434	219	376	196	310	171
		67	454	291	407	269	354	246	295	221	228	194
		62	380	320	332	296	279	268	235	235	199	199
	12,500 .08	72	583	287	531	267	475	245	412	221	341	194
		67	499	329	448	306	390	282	325	255	252	225
		62	420	367	367	341	310	310	269	269	228	228

LEGEND

- BF** — Bypass Factor
db — Dry–Bulb Temp (°F)
Ewb — Entering Wet–Bulb Temp (°F)
lwb — Leaving Wet–Bulb Temp (°F)
SHC — Sensible Heat Capacity (1000 Btuh)
TC — Total Capacity (1000 Btuh)

NOTES:

1. Ratings based on approximately 15°F superheat leaving coil.
2. Direct interpolation is permissible. Do not extrapolate.
3. Dashes indicate coil loading limits are exceeded.
4. Evaporator fan heat not deducted from ratings.

5. Formulas:

$$\text{Leaving db} = \text{entering db} - \frac{\text{sensible heat capacity (Btuh)}}{1.1 \times \text{cfm}}$$

$$\text{Leaving db} = \text{wet–bulb temperature corresponding to enthalpy of air leaving coil (} h_{lwb} \text{)}$$

$$h_{lwb} = h_{ewb} - \frac{\text{total capacity (Btuh)}}{4.5 \times \text{cfm}}$$

where h_{lwb} = enthalpy of air entering coil

6. SHC is based on 80°F db temperature of air entering evaporator coil.

PERFORMANCE DATA (CONT.)

FAS COOLING CAPACITIES – SI

UNIT FAS	EVAPORATOR AIR		COIL REFRIGERANT TEMP (°C)									
	Airflow (L/s) BF	Ewb (°C)	-1		2		4		7		10	
			TC	SHC	TC	SHC	TC	SHC	TC	SHC	TC	SHC
072	850 .06	22	36	17	33	16	29	14	25	13	21	11
		19	31	19	27	17	24	16	20	14	15	12
		17	25	20	22	18	18	16	14	14	12	12
	1130 .10	22	42	20	38	19	34	17	30	15	24	13
		19	36	22	32	21	28	19	23	17	18	15
		17	30	24	26	22	22	20	18	18	15	15
1420 .12	22	46	23	42	21	38	19	33	17	27	15	
	19	39	25	35	24	31	21	25	19	20	17	
	17	33	28	29	26	24	23	20	20	17	17	
091	1060 .06	22	45	22	41	20	37	18	32	16	26	14
		19	38	23	34	21	30	19	24	17	19	15
		17	32	25	27	23	23	21	18	18	15	15
	1420 .10	22	52	25	48	23	43	21	37	19	30	16
		19	44	28	40	26	35	23	29	21	22	18
		17	37	30	32	28	27	25	22	22	19	19
1770 .12	22	58	28	53	26	47	24	41	21	34	19	
	19	49	32	44	29	38	27	32	24	25	21	
	17	41	35	36	32	30	29	26	26	22	22	
120	1420 .05	22	58	28	53	26	47	23	41	21	33	18
		19	49	31	44	28	38	25	31	22	24	19
		17	41	33	35	30	30	27	24	24	20	20
	1890 .07	22	67	33	61	30	54	27	47	24	38	21
		19	57	36	51	33	44	30	36	27	28	24
		17	47	40	41	36	35	33	29	29	25	25
2360 .12	22	73	36	67	33	60	31	51	27	42	24	
	19	63	41	56	38	49	35	40	31	31	28	
	17	52	45	46	42	39	38	33	33	28	28	
150	1770 .06	22	73	35	67	32	59	29	51	26	41	22
		19	62	38	55	35	47	31	39	28	30	24
		17	51	40	44	37	37	33	29	29	25	25
	2360 .08	22	85	41	77	38	68	34	59	30	47	26
		19	72	45	64	41	55	38	45	33	35	29
		17	60	49	52	45	43	40	35	35	30	30
2980 .10	22	93	45	85	42	76	38	65	34	53	29	
	19	79	51	71	47	61	43	50	39	39	34	
	17	66	56	57	52	48	47	41	41	34	34	
180	2120 .03	22	91	44	82	40	73	36	63	32	51	27
		19	76	47	68	43	58	38	48	34	37	29
		17	63	50	55	45	45	41	36	36	30	30
	2830 .05	22	106	51	96	47	86	43	73	37	60	32
		19	89	56	79	51	69	46	57	41	44	36
		17	74	60	65	55	54	50	44	44	37	37
3540 .08	22	118	57	107	53	95	48	82	43	67	37	
	19	100	64	89	59	77	54	64	48	49	42	
	17	84	70	72	65	60	58	50	50	42	42	

LEGEND

- BF** — Bypass Factor
db — Dry–Bulb Temp (°F)
Ewb — Entering Wet–Bulb Temp (°F)
lwb — Leaving Wet–Bulb Temp (°F)
SHC — Sensible Heat Capacity (1000 Btuh)
TC — Total Capacity (1000 Btuh)

NOTES:

1. Ratings based on approximately 15°F superheat leaving coil.
2. Direct interpolation is permissible. Do not extrapolate.
3. Dashes indicate coil loading limits are exceeded.
4. Evaporator fan heat not deducted from ratings.

5. Formulas:

$$\text{Leaving db} = \text{entering db} - \frac{\text{sensible heat capacity (Btuh)}}{1.1 \times \text{cfm}}$$

$$\text{Leaving db} = \text{wet–bulb temperature corresponding to enthalpy of air leaving coil (h}_{lwb}\text{)}$$

$$h_{lwb} = h_{ewb} - \frac{\text{total capacity (Btuh)}}{4.5 \times \text{cfm}}$$

where h_{lwb} = enthalpy of air entering coil

6. SHC is based on 80°F db temperature of air entering evaporator coil.

PERFORMANCE DATA (CONT.)

FAS COOLING CAPACITIES – SI (cont.)

UNIT FAS	EVAPORATOR AIR		COIL REFRIGERANT TEMP (°C)									
	Airflow (L/s) BF	Ewb (°C)	-1		2		4		7		10	
			TC	SHC	TC	SHC	TC	SHC	TC	SHC	TC	SHC
240	2830 .03	22	120	58	109	53	97	48	80	41	68	36
		19	101	62	90	57	78	52	64	46	50	40
		17	84	67	73	61	61	55	48	48	41	41
	3780 .06	22	138	67	126	62	112	56	96	50	79	43
		19	117	74	105	68	91	62	75	56	58	49
		17	98	81	85	74	71	67	59	59	50	50
	4720 .07	22	151	74	138	69	123	63	106	56	87	49
		19	129	84	116	78	100	71	83	64	64	57
		17	108	93	94	86	79	78	68	68	58	58
300	3540 .04	22	138	66	125	61	111	55	96	49	79	42
		19	116	72	104	66	90	60	75	54	58	47
		17	96	78	84	72	70	65	57	57	48	48
	4720 .06	22	157	76	143	70	127	64	110	57	91	50
		19	133	85	119	79	104	72	86	65	67	57
		17	111	94	97	87	82	79	69	69	58	58
	5900 .08	22	171	84	156	78	139	72	121	65	100	57
		19	146	96	131	90	114	83	95	75	74	66
		17	123	107	107	100	91	91	79	79	67	67

LEGEND

- BF** — Bypass Factor
db — Dry–Bulb Temp (°F)
Ewb — Entering Wet–Bulb Temp (°F)
lwb — Leaving Wet–Bulb Temp (°F)
SHC — Sensible Heat Capacity (1000 Btuh)
TC — Total Capacity (1000 Btuh)

NOTES:

1. Ratings based on approximately 15°F superheat leaving coil.
2. Direct interpolation is permissible. Do not extrapolate.
3. Dashes indicate coil loading limits are exceeded.
4. Evaporator fan heat not deducted from ratings.

5. Formulas:

$$\text{Leaving db} = \text{entering db} - \frac{\text{sensible heat capacity (Btuh)}}{1.1 \times \text{cfm}}$$

$$\text{Leaving db} = \text{wet–bulb temperature corresponding to enthalpy of air leaving coil (} h_{lwb} \text{)}$$

$$h_{lwb} = h_{ewb} - \frac{\text{total capacity (Btuh)}}{4.5 \times \text{cfm}}$$

where h_{lwb} = enthalpy of air entering coil

6. SHC is based on 80°F db temperature of air entering evaporator coil.

PERFORMANCE DATA (CONT.)

HYDRONIC HEATING CAPACITIES — English

UNIT	AIRFLOW (Cfm)	1-ROW STEAM*		2-ROW HOT WATER COIL†			
		Cap.	Ldb	Cap.	Ldb	Water Flow (Gpm)	PD
FAS 072	1,800	146	134	156.0	140	15.6	3.4
	2,400	173	126	183.0	131	18.3	4.3
	3,000	209	123	206.0	124	20.6	5.2
FAS 091	2,250	168	129	174.0	133	17.4	4.0
	3,000	209	123	206.0	124	20.6	5.2
	3,750	240	117	238.0	118	23.8	6.5
FAS 120	3,000	209	123	299.0	152	29.9	5.0
	4,000	243	115	275.0	124	27.5	6.6
	5,000	279	111	316.0	119	31.6	8.2
FAS 150	3,750	370	150	362.0	149	36.2	4.2
	5,000	425	137	409.0	136	40.9	5.1
	6,250	465	128	456.0	128	45.6	6.0
FAS 180	4,500	402	141	412.0	145	41.2	4.5
	6,000	458	129	471.0	133	47.1	5.5
	7,500	479	118	529.0	125	52.9	6.6
FAS 240	6,000	458	129	506.0	138	50.6	5.1
	8,000	487	115	584.0	128	58.4	6.3
	10,000	499	105	652.0	120	65.2	7.5
FAS 300	7,500	511	122	649.0	140	64.9	5.7
	10,000	575	112	752.0	130	75.2	7.1
	12,500	626	106	842.0	122	84.2	8.5

LEGEND:

Cap. — Capacity (Btuh in thousands)

Ldb — Leaving Air Dry Bulb Temp (°F)

PD — Pressure Drop (ft water)

* Based on 5 psig steam, 60°F entering-air temperature. All steam coils are non-freeze type.

† Based on 200°F entering water, 20°F water temperature drop, 60°F entering-air temperature.

NOTES:

- Maximum operating limits for heating coils: 20 psig at 260°F.
- Leaving db = ent db (°F) + $\frac{\text{Capacity (Btuh)}}{1.1 \times \text{cfm}}$
- See Heating Correction Factors table.

HYDRONIC HEATING CAPACITIES — SI

UNIT	AIRFLOW (L/s)	1-ROW STEAM*		2-ROW HOT WATER COIL†			
		Cap.	Ldb	Cap.	Ldb	Water Flow (L/s)	PD
FAS 072	850	43	57	46	59	1.0	10.2
	1150	53	53	53	53	1.2	12.8
	1450	62	51	61	50	1.3	16.0
FAS 091	1000	48	55	50	56	1.1	11.5
	1400	59	50	60	50	1.3	15.3
	1800	71	47	70	47	1.5	19.5
FAS 120	1450	62	50	88	65	1.9	15.0
	1900	72	46	90	54	2.0	24.7
	2350	82	44	93	48	2.0	24.5
FAS 150	1750	108	66	106	65	2.3	12.4
	2350	122	58	120	57	2.6	15.2
	2950	136	53	134	52	2.9	17.9
FAS 180	2100	117	61	120	62	2.6	13.3
	2800	129	53	137	55	3.0	16.2
	3500	140	48	154	51	3.3	19.5
FAS 240	2900	135	53	150	58	3.3	15.6
	3800	140	46	170	52	3.7	18.6
	4700	146	41	191	49	4.1	22.3
FAS 300	3500	149	50	189	60	4.1	16.9
	4700	166	44	218	53	4.7	20.8
	5900	183	41	247	50	5.4	25.4

LEGEND:

Cap. — Capacity (Btuh in thousands)

Ldb — Leaving Air Dry Bulb Temp (°C)

PD — Pressure Drop (ft water)

* Based on 34.5 kPag steam, 15.6°C entering-air temperature. All steam coils are non-freeze type.

† Based on 93.3°C entering water temperature, 11.1°C water temperature drop, 15.6°C entering-air temperature.

NOTES:

- Maximum operating limits for heating coils: 138 kPag at 126.7°C.
- Leaving db = ent db (°C) + $\frac{\text{Capacity (kW)}}{1.23 \times 10^{-3} \times \text{L/s}}$
- See Heating Correction Factors table.

HEATING CORRECTION FACTORS — English

HOT WATER COIL						
Water Temp Drop (°F)	Ent Water Temp (°F)	Entering-Air Temp (°F)				
		40	50	60	70	80
10	140	0.72	0.64	0.57	0.49	0.41
	160	0.89	0.81	0.74	0.66	0.58
	180	1.06	0.98	0.90	0.83	0.75
	200	1.22	1.15	1.07	1.00	0.92
	220	1.39	1.32	1.24	1.17	1.09
20	140	0.64	0.57	0.49	0.41	0.33
	160	0.81	0.74	0.66	0.58	0.51
	180	0.98	0.91	0.83	0.75	0.68
	200	1.15	1.08	1.00	0.93	0.85
	220	1.32	1.25	1.17	1.10	1.02
30	140	0.56	0.49	0.41	0.33	0.24
	160	0.74	0.66	0.58	0.51	0.43
	180	0.91	0.83	0.76	0.68	0.60
	200	1.08	1.00	0.93	0.85	0.78
	220	1.25	1.18	1.10	1.03	0.95

STEAM COIL						
Steam Pressure (psig)	Entering-Air Temp (°F)					
	40	50	60	70	80	
0	1.06	0.98	0.91	0.85	0.78	
2	1.09	1.02	0.95	0.89	0.82	
5	1.13	1.06	1.00	0.93	0.87	

NOTE: Multiply capacity given in the Hydronic Heating Capacities table by the correction factor for conditions at which unit is actually operating. Correct leaving-air temperature using formula in Note 2 of Hydronic Heating Capacities table.

HEATING CORRECTION FACTORS — SI

HOT WATER COIL						
Water Temp Drop (°C)	Ent Water Temp (°C)	Entering-Air Temp (°C)				
		4	10	16	20	25
5	60	0.72	0.64	0.55	0.50	0.43
	70	0.87	0.79	0.71	0.65	0.58
	80	1.02	0.94	0.86	0.80	0.73
	90	1.17	1.09	1.01	0.95	0.89
	100	1.32	1.24	1.16	1.10	1.04
11	60	0.65	0.56	0.48	0.42	0.35
	70	0.80	0.72	0.63	0.58	0.51
	80	0.95	0.87	0.79	0.73	0.66
	90	1.10	1.02	0.94	0.89	0.82
	100	1.26	1.18	1.09	1.04	0.97
16	60	0.56	0.48	0.39	0.33	0.26
	70	0.72	0.63	0.55	0.49	0.42
	80	0.87	0.79	0.70	0.65	0.58
	90	1.02	0.94	0.86	0.81	0.74
	100	1.18	1.10	1.02	0.97	0.90

STEAM COIL						
Steam Pressure (kPag)	Entering-Air Temp (°C)					
	4	10	16	20	25	
0	1.07	0.99	0.91	0.86	0.80	
14	1.10	1.02	0.95	0.90	0.84	
35	1.14	1.07	0.99	0.95	0.89	

NOTE: Multiply capacity given in the Hydronic Heating Capacities table by the correction factor for conditions at which unit is actually operating. Correct leaving-air temperature using formula in Note 2 of Hydronic Heating Capacities table.

PERFORMANCE DATA (CONT.)

FAN PERFORMANCE DATA — FAS 0.0-1.2 in. wg ESP — 60 Hz, English

UNIT FAS	AIRFLOW (Cfm)	EXTERNAL STATIC PRESSURE (in. wg)													
		0.0		0.2		0.4		0.6		0.8		1.0		1.2	
		Rpm	Bhp	Rpm	Bhp	Rpm	Bhp	Rpm	Bhp	Rpm	Bhp	Rpm	Bhp	Rpm	Bhp
072	1,800	419	0.21	471	0.26	564	0.37	649	0.49	<u>727</u>	<u>0.63</u>	<u>797</u>	<u>0.77</u>	<u>862</u>	<u>0.92</u>
	2,100	471	0.31	519	0.37	602	0.49	679	<u>0.62</u>	<u>751</u>	<u>0.77</u>	<u>819</u>	<u>0.92</u>	<u>882</u>	<u>1.09</u>
	2,400	524	0.44	568	0.51	645	0.64	715	<u>0.79</u>	<u>781</u>	<u>0.94</u>	<u>844</u>	<u>1.11</u>	<u>905</u>	<u>1.28</u>
	2,700	578	0.61	619	0.69	<u>690</u>	<u>0.84</u>	<u>755</u>	<u>0.99</u>	<u>816</u>	<u>1.15</u>	<u>875</u>	<u>1.33</u>	<u>932</u>	<u>1.51</u>
	3,000	633	0.81	<u>671</u>	<u>0.90</u>	<u>738</u>	<u>1.07</u>	<u>799</u>	<u>1.24</u>	<u>856</u>	<u>1.41</u>	<u>910</u>	<u>1.60</u>	<u>963</u>	<u>1.79</u>
091	2,250	290	0.10	510	0.39	594	0.51	669	0.65	739	0.79	<u>806</u>	<u>0.95</u>	<u>870</u>	<u>1.12</u>
	2,600	349	0.19	561	0.55	640	0.70	709	0.84	<u>773</u>	<u>1.00</u>	<u>834</u>	<u>1.16</u>	<u>893</u>	<u>1.34</u>
	3,000	579	0.70	621	0.79	695	0.96	<u>759</u>	<u>1.12</u>	<u>818</u>	<u>1.30</u>	<u>874</u>	<u>1.47</u>	<u>928</u>	<u>1.66</u>
	3,400	646	0.99	683	1.09	<u>752</u>	<u>1.29</u>	<u>813</u>	<u>1.48</u>	<u>869</u>	<u>1.67</u>	<u>920</u>	<u>1.86</u>	<u>970</u>	<u>2.06</u>
	3,750	705	1.31	739	1.42	<u>804</u>	<u>1.63</u>	<u>862</u>	<u>1.85</u>	<u>915</u>	<u>2.05</u>	<u>964</u>	<u>2.26</u>	<u>1011</u>	<u>2.48</u>
120	3,000	421	0.35	592	0.73	670	0.90	737	1.06	<u>797</u>	<u>1.23</u>	<u>854</u>	<u>1.41</u>	<u>908</u>	<u>1.59</u>
	3,500	626	0.98	664	1.08	735	1.28	798	1.48	<u>855</u>	<u>1.67</u>	<u>908</u>	<u>1.87</u>	<u>958</u>	<u>2.07</u>
	4,000	706	1.42	738	1.54	803	1.77	862	2.00	<u>917</u>	<u>2.23</u>	<u>967</u>	<u>2.45</u>	<u>1014</u>	<u>2.67</u>
	4,500	786	1.99	815	2.12	<u>873</u>	<u>2.39</u>	<u>929</u>	<u>2.65</u>	<u>980</u>	<u>2.90</u>	<u>1028</u>	<u>3.16</u>	<u>1073</u>	<u>3.41</u>
	5,000	<u>867</u>	<u>2.70</u>	<u>893</u>	<u>2.84</u>	<u>946</u>	<u>3.14</u>	<u>997</u>	<u>3.43</u>	<u>1046</u>	<u>3.72</u>	<u>1092</u>	<u>4.00</u>	<u>1135</u>	<u>4.28</u>
150	3,750	410	0.43	467	0.55	567	0.83	649	1.12	721	1.41	<u>788</u>	<u>1.72</u>	<u>851</u>	<u>2.05</u>
	4,300	455	0.62	504	0.74	599	1.05	679	1.38	<u>748</u>	<u>1.70</u>	<u>811</u>	<u>2.04</u>	<u>871</u>	<u>2.39</u>
	5,000	514	0.92	556	1.06	641	1.39	718	1.76	<u>786</u>	<u>2.14</u>	<u>847</u>	<u>2.52</u>	<u>903</u>	<u>2.91</u>
	5,700	575	1.32	612	1.47	686	1.82	<u>759</u>	<u>2.23</u>	<u>825</u>	<u>2.66</u>	<u>884</u>	<u>3.09</u>	<u>939</u>	<u>3.52</u>
	6,250	624	1.71	657	1.87	725	2.24	<u>793</u>	<u>2.66</u>	<u>856</u>	<u>3.12</u>	<u>915</u>	<u>3.59</u>	<u>969</u>	<u>4.06</u>
180	4,500	437	0.61	483	0.72	576	1.01	660	1.35	<u>732</u>	<u>1.69</u>	<u>797</u>	<u>2.03</u>	<u>856</u>	<u>2.38</u>
	5,300	499	0.95	538	1.07	617	1.37	696	1.74	<u>767</u>	<u>2.13</u>	<u>830</u>	<u>2.53</u>	<u>888</u>	<u>2.94</u>
	6,000	555	1.34	590	1.48	659	1.79	<u>730</u>	<u>2.17</u>	<u>798</u>	<u>2.59</u>	<u>860</u>	<u>3.04</u>	<u>918</u>	<u>3.49</u>
	6,800	620	1.91	651	2.06	712	2.39	<u>774</u>	<u>2.78</u>	<u>836</u>	<u>3.22</u>	<u>896</u>	<u>3.71</u>	<u>952</u>	<u>4.21</u>
	7,500	677	2.52	706	2.69	<u>761</u>	<u>3.04</u>	<u>817</u>	<u>3.44</u>	<u>873</u>	<u>3.89</u>	<u>929</u>	<u>4.39</u>	<u>984</u>	<u>4.93</u>
240	6,000	542	1.29	577	1.42	646	1.72	716	2.09	785	2.51	849	2.95	<u>907</u>	<u>3.40</u>
	7,000	620	1.99	652	2.15	711	2.48	771	2.85	831	3.28	<u>890</u>	<u>3.76</u>	<u>947</u>	<u>4.27</u>
	8,000	700	2.92	728	3.10	781	3.46	833	3.85	<u>885</u>	<u>4.29</u>	<u>938</u>	<u>4.78</u>	<u>990</u>	<u>5.32</u>
	9,000	781	4.10	806	4.30	854	4.71	<u>900</u>	<u>5.13</u>	<u>946</u>	<u>5.58</u>	<u>993</u>	<u>6.08</u>	<u>1039</u>	<u>6.62</u>
	10,000	862	5.56	<u>885</u>	<u>5.79</u>	<u>929</u>	<u>6.24</u>	<u>971</u>	<u>6.70</u>	<u>1012</u>	<u>7.18</u>	<u>1054</u>	<u>7.69</u>	<u>1096</u>	<u>8.24</u>
300	7,500	476	1.39	510	1.58	579	1.99	644	2.40	701	2.81	752	3.29	804	3.96
	8,750	545	2.14	574	2.35	633	2.81	691	3.29	747	3.77	797	4.25	<u>842</u>	<u>4.76</u>
	10,000	615	3.12	641	3.36	692	3.87	743	4.41	794	4.96	<u>843</u>	<u>5.51</u>	<u>888</u>	<u>6.05</u>
	11,250	685	4.37	709	4.64	754	5.20	800	5.79	<u>845</u>	<u>6.40</u>	<u>891</u>	<u>7.02</u>	<u>935</u>	<u>7.64</u>
	12,500	756	5.92	778	6.22	819	6.83	860	<u>7.47</u>	<u>901</u>	<u>8.14</u>	<u>942</u>	<u>8.83</u>	<u>983</u>	<u>9.52</u>

LEGEND

Bhp — Brake Horsepower Input to Fan

ESP — External Static Pressure

Bold indicates field-supplied drive or motor is required.

Plain type indicates standard motor and standard drive.

Underline indicates a different motor and drive combination other than the standard motor and standard drive combination is required. Refer to fan motor and drive tables to complete selection.

NOTES:

Maximum allowable fan speed is 1100 rpm for unit sizes 028 and 030; 1200 rpm for all other sizes. Fan performance is based on deductions for wet coil, clean 2-in. filters, and unit casing. See table below for factory-supplied filter pressure drop. For 60 Hz units, the medium-static drive and standard motor combination is not available for 028 size.

PERFORMANCE DATA (CONT.)

FAN PERFORMANCE DATA — FAS 1.4-2.4 in. wg ESP — 60 Hz, English

UNIT FAS	AIRFLOW (Cfm)	EXTERNAL STATIC PRESSURE (in. wg)											
		1.4		1.6		1.8		2.0		2.2		2.4	
		Rpm	Bhp	Rpm	Bhp	Rpm	Bhp	Rpm	Bhp	Rpm	Bhp	Rpm	Bhp
072	1,800	<u>921</u>	1.07	<u>975</u>	<u>1.23</u>	<u>1026</u>	<u>1.39</u>	<u>1074</u>	<u>1.55</u>	1120	1.72	1164	1.90
	2,100	<u>942</u>	1.26	<u>997</u>	<u>1.43</u>	<u>1048</u>	<u>1.61</u>	1097	1.79	1143	1.97	1186	2.16
	2,400	<u>963</u>	1.47	<u>1017</u>	<u>1.66</u>	<u>1069</u>	<u>1.85</u>	1118	2.05	1164	2.25	—	—
	2,700	<u>987</u>	1.71	<u>1039</u>	<u>1.91</u>	1090	2.12	1138	2.33	1185	2.55	—	—
	3,000	<u>1015</u>	1.99	<u>1065</u>	<u>2.20</u>	1113	2.42	1161	2.65	—	—	—	—
091	2,250	<u>930</u>	1.29	<u>986</u>	1.47	<u>1039</u>	<u>1.65</u>	<u>1089</u>	<u>1.84</u>	<u>1136</u>	<u>2.03</u>	<u>1181</u>	<u>2.22</u>
	2,600	<u>950</u>	1.53	<u>1005</u>	1.72	<u>1057</u>	1.92	<u>1107</u>	<u>2.13</u>	<u>1154</u>	<u>2.33</u>	—	—
	3,000	<u>980</u>	1.86	<u>1031</u>	2.06	<u>1081</u>	2.27	<u>1129</u>	<u>2.49</u>	<u>1175</u>	<u>2.72</u>	—	—
	3,400	<u>1018</u>	2.26	<u>1065</u>	2.48	<u>1111</u>	2.70	<u>1156</u>	<u>2.93</u>	—	—	—	—
	3,750	<u>1057</u>	2.69	<u>1101</u>	2.92	<u>1144</u>	3.15	<u>1186</u>	<u>3.39</u>	—	—	—	—
120	3,000	<u>961</u>	1.78	<u>1012</u>	1.98	<u>1062</u>	2.19	<u>1111</u>	<u>2.41</u>	<u>1158</u>	2.64	—	—
	3,500	<u>1005</u>	2.27	<u>1052</u>	2.49	<u>1098</u>	2.71	<u>1142</u>	<u>2.94</u>	<u>1186</u>	3.18	—	—
	4,000	<u>1058</u>	2.90	<u>1101</u>	3.13	<u>1143</u>	3.36	<u>1184</u>	<u>3.60</u>	—	—	—	—
	4,500	<u>1116</u>	3.66	<u>1157</u>	3.91	<u>1196</u>	4.16	—	—	—	—	—	—
	5,000	<u>1176</u>	4.56	—	—	—	—	—	—	—	—	—	—
150	3,750	<u>912</u>	2.39	<u>971</u>	2.76	<u>1028</u>	3.14	<u>1083</u>	3.54	1135	3.95	1185	4.36
	4,300	<u>928</u>	2.75	<u>982</u>	3.13	<u>1036</u>	3.53	<u>1087</u>	3.94	1138	4.37	1187	4.81
	5,000	<u>956</u>	3.30	<u>1007</u>	3.71	<u>1056</u>	4.13	1104	4.56	1151	5.00	1196	5.46
	5,700	<u>990</u>	3.96	<u>1039</u>	4.40	<u>1086</u>	4.85	1130	5.31	1174	5.78	—	—
	6,250	<u>1019</u>	4.54	<u>1067</u>	5.02	1112	5.50	1156	5.99	1198	6.49	—	—
180	4,500	<u>912</u>	2.75	<u>967</u>	3.12	<u>1019</u>	3.52	<u>1070</u>	3.92	<u>1120</u>	4.35	<u>1168</u>	4.79
	5,300	<u>942</u>	3.34	<u>992</u>	3.76	<u>1041</u>	4.18	<u>1088</u>	4.61	<u>1134</u>	5.06	1179	5.52
	6,000	<u>971</u>	3.95	<u>1020</u>	4.40	<u>1067</u>	4.86	<u>1112</u>	5.33	<u>1156</u>	5.81	1198	6.29
	6,800	<u>1005</u>	4.72	<u>1054</u>	5.23	<u>1101</u>	5.75	<u>1145</u>	6.27	1187	6.79	—	—
	7,500	<u>1036</u>	5.48	<u>1084</u>	6.04	<u>1131</u>	6.61	1174	7.17	—	—	—	—
240	6,000	<u>961</u>	3.86	<u>1011</u>	4.31	<u>1058</u>	4.77	<u>1104</u>	5.24	<u>1147</u>	5.71	—	—
	7,000	<u>1000</u>	4.79	<u>1050</u>	5.32	<u>1097</u>	5.85	<u>1142</u>	6.38	<u>1184</u>	6.91	—	—
	8,000	<u>1041</u>	5.88	<u>1090</u>	6.47	<u>1137</u>	7.07	<u>1181</u>	7.67	—	—	—	—
	9,000	<u>1086</u>	7.21	<u>1133</u>	7.82	<u>1178</u>	8.47	—	—	—	—	—	—
	10,000	<u>1138</u>	8.83	<u>1180</u>	9.46	—	—	—	—	—	—	—	—
300	7,500	<u>874</u>	5.33	<u>897</u>	5.91	<u>940</u>	6.80	<u>990</u>	7.50	—	—	—	—
	8,750	<u>886</u>	5.36	<u>930</u>	6.13	<u>982</u>	7.32	<u>1020</u>	8.10	—	—	—	—
	10,000	<u>930</u>	6.60	<u>969</u>	7.20	<u>1007</u>	7.89	<u>1045</u>	8.71	—	—	—	—
	11,250	<u>976</u>	8.25	<u>1014</u>	8.86	<u>1051</u>	9.49	1086	10.17	—	—	—	—
	12,500	<u>1023</u>	10.20	<u>1061</u>	10.88	1097	11.56	—	—	—	—	—	—

LEGEND

Bhp — Brake Horsepower Input to Fan

ESP — External Static Pressure

Bold indicates field-supplied drive or motor is required.

Plain type indicates standard motor and standard drive.

Underline indicates a different motor and drive combination other than the standard motor and standard drive combination is required. Refer to fan motor and drive tables to complete selection.

NOTES:

Maximum allowable fan speed is 1100 rpm for unit sizes 028 and 030; 1200 rpm for all other sizes. Fan performance is based on deductions for wet coil, clean 2-in. filters, and unit casing. See table below for factory-supplied filter pressure drop. For 60 Hz units, the medium-static drive and standard motor combination is not available for 028 size.

PERFORMANCE DATA (CONT.)

FAN PERFORMANCE DATA — FAS 0-300 Pa ESP — 60 Hz, SI

UNIT FAS)	AIRFLOW (L/s)	EXTERNAL STATIC PRESSURE (Pa)													
		0		50		100		150		200		250		300	
		r/s	kW	r/s	kW	r/s	kW	r/s	kW	r/s	kW	r/s	kW	r/s	kW
072	850	6.98	0.16	7.86	0.19	9.40	0.27	10.81	0.37	<u>12.11</u>	<u>0.47</u>	<u>13.29</u>	<u>0.57</u>	<u>14.36</u>	<u>0.69</u>
	990	7.84	0.23	8.64	0.27	10.03	0.36	<u>11.31</u>	<u>0.46</u>	<u>12.52</u>	<u>0.57</u>	<u>13.65</u>	<u>0.69</u>	<u>14.71</u>	<u>0.81</u>
	1130	8.73	0.33	9.46	0.38	10.75	0.48	<u>11.91</u>	<u>0.59</u>	<u>13.01</u>	<u>0.70</u>	<u>14.07</u>	<u>0.83</u>	<u>15.08</u>	<u>0.96</u>
	1270	9.63	0.45	10.31	0.51	<u>11.51</u>	<u>0.62</u>	<u>12.58</u>	<u>0.74</u>	<u>13.60</u>	<u>0.86</u>	<u>14.58</u>	<u>0.99</u>	<u>15.53</u>	<u>1.13</u>
	1420	10.55	0.61	<u>11.18</u>	<u>0.67</u>	<u>12.30</u>	<u>0.80</u>	<u>13.31</u>	<u>0.92</u>	<u>14.26</u>	<u>1.05</u>	<u>15.17</u>	<u>1.19</u>	<u>16.05</u>	<u>1.33</u>
091	1060	4.83	0.07	8.50	0.29	9.91	0.38	11.15	0.48	12.32	0.59	<u>13.44</u>	<u>0.71</u>	<u>14.50</u>	<u>0.83</u>
	1230	5.81	0.14	9.35	0.41	10.67	0.52	11.81	0.63	<u>12.88</u>	<u>0.74</u>	<u>13.90</u>	<u>0.87</u>	<u>14.89</u>	<u>1.00</u>
	1420	9.65	0.52	10.35	0.59	11.59	0.71	<u>12.66</u>	<u>0.84</u>	<u>13.64</u>	<u>0.97</u>	<u>14.57</u>	<u>1.10</u>	<u>15.47</u>	<u>1.24</u>
	1600	10.76	0.74	11.39	0.81	<u>12.54</u>	<u>0.96</u>	<u>13.55</u>	<u>1.10</u>	<u>14.48</u>	<u>1.24</u>	<u>15.34</u>	<u>1.39</u>	<u>16.17</u>	<u>1.53</u>
	1770	11.74	0.97	12.32	1.06	<u>13.40</u>	<u>1.22</u>	<u>14.37</u>	<u>1.38</u>	<u>15.25</u>	<u>1.53</u>	<u>16.07</u>	<u>1.69</u>	<u>16.86</u>	<u>1.85</u>
120	1420	7.02	0.26	9.86	0.54	11.17	0.67	12.28	0.79	<u>13.29</u>	<u>0.92</u>	<u>14.23</u>	<u>1.05</u>	<u>15.14</u>	<u>1.19</u>
	1650	10.44	0.73	11.06	0.80	12.25	0.96	13.31	1.10	<u>14.25</u>	<u>1.25</u>	<u>15.13</u>	<u>1.39</u>	<u>15.96</u>	<u>1.54</u>
	1890	11.76	1.06	12.31	1.15	13.38	1.32	14.37	1.49	<u>15.28</u>	<u>1.66</u>	<u>16.11</u>	<u>1.83</u>	<u>16.89</u>	<u>1.99</u>
	2120	13.10	1.48	13.59	1.58	<u>14.55</u>	<u>1.78</u>	<u>15.48</u>	<u>1.97</u>	<u>16.34</u>	<u>2.17</u>	<u>17.14</u>	<u>2.35</u>	<u>17.89</u>	<u>2.54</u>
	2360	14.45	2.01	<u>14.89</u>	<u>2.12</u>	<u>15.76</u>	<u>2.34</u>	<u>16.62</u>	<u>2.56</u>	<u>17.43</u>	<u>2.77</u>	<u>18.20</u>	<u>2.98</u>	<u>18.92</u>	<u>3.19</u>
150	1770	6.84	0.32	7.78	0.41	9.46	0.62	10.82	0.83	12.02	1.05	<u>13.13</u>	<u>1.28</u>	<u>14.19</u>	<u>1.53</u>
	2030	7.58	0.46	8.40	0.55	9.98	0.78	11.31	1.03	<u>12.47</u>	<u>1.27</u>	<u>13.52</u>	<u>1.52</u>	<u>14.51</u>	<u>1.78</u>
	2360	8.57	0.69	9.27	0.79	10.68	1.04	11.96	1.31	<u>13.09</u>	<u>1.60</u>	<u>14.11</u>	<u>1.88</u>	<u>15.05</u>	<u>2.17</u>
	2690	9.59	0.99	10.20	1.10	11.44	1.36	<u>12.64</u>	<u>1.66</u>	<u>13.74</u>	<u>1.98</u>	<u>14.74</u>	<u>2.30</u>	<u>15.65</u>	<u>2.63</u>
	2950	10.40	1.28	10.96	1.39	12.09	1.67	<u>13.21</u>	<u>1.98</u>	<u>14.27</u>	<u>2.33</u>	<u>15.25</u>	<u>2.68</u>	<u>16.15</u>	<u>3.03</u>
180	2120	7.28	0.45	8.05	0.54	9.60	0.75	11.00	1.00	<u>12.21</u>	<u>1.26</u>	<u>13.28</u>	<u>1.51</u>	<u>14.27</u>	<u>1.78</u>
	2500	8.32	0.71	8.97	0.80	10.29	1.02	11.59	1.30	<u>12.78</u>	<u>1.59</u>	<u>13.84</u>	<u>1.89</u>	<u>14.80</u>	<u>2.19</u>
	2830	9.25	1.00	9.83	1.10	10.99	1.33	<u>12.16</u>	<u>1.62</u>	<u>13.29</u>	<u>1.93</u>	<u>14.34</u>	<u>2.27</u>	<u>15.30</u>	<u>2.60</u>
	3210	10.33	1.42	10.85	1.54	11.87	1.78	<u>12.90</u>	<u>2.07</u>	<u>13.93</u>	<u>2.40</u>	<u>14.93</u>	<u>2.76</u>	<u>15.87</u>	<u>3.14</u>
	3540	11.29	1.88	11.77	2.01	<u>12.69</u>	<u>2.27</u>	<u>13.62</u>	<u>2.56</u>	<u>14.56</u>	<u>2.90</u>	<u>15.49</u>	<u>3.27</u>	<u>16.40</u>	<u>3.67</u>
240	2830	9.03	0.96	9.62	1.06	10.77	1.29	11.94	1.56	13.08	1.87	14.15	2.20	<u>15.12</u>	<u>2.54</u>
	3300	10.34	1.48	10.86	1.60	11.85	1.85	12.84	2.12	13.85	2.45	<u>14.84</u>	<u>2.80</u>	<u>15.78</u>	<u>3.18</u>
	3780	11.67	2.17	12.14	2.31	13.02	2.58	13.88	2.87	<u>14.75</u>	<u>3.20</u>	<u>15.63</u>	<u>3.56</u>	<u>16.50</u>	<u>3.96</u>
	4250	13.01	3.05	13.44	3.21	14.23	3.51	<u>15.00</u>	<u>3.82</u>	<u>15.77</u>	<u>4.16</u>	<u>16.54</u>	<u>4.53</u>	<u>17.32</u>	<u>4.94</u>
	4720	14.36	4.15	<u>14.75</u>	<u>4.32</u>	<u>15.48</u>	<u>4.66</u>	<u>16.18</u>	<u>4.99</u>	<u>16.87</u>	<u>5.35</u>	<u>17.56</u>	<u>5.73</u>	<u>18.26</u>	<u>6.14</u>
300	3540	7.94	1.04	8.51	1.18	9.65	1.48	10.73	1.79	11.68	2.10	12.53	2.46	13.40	2.95
	4130	9.08	1.59	9.57	1.75	10.55	2.10	11.52	2.46	12.45	2.81	13.28	3.17	<u>14.04</u>	<u>3.55</u>
	4720	10.24	2.33	10.68	2.51	11.53	2.88	12.39	3.29	13.24	3.70	<u>14.05</u>	<u>4.11</u>	<u>14.80</u>	<u>4.51</u>
	5310	11.42	3.26	11.81	3.46	12.57	3.88	13.33	4.32	<u>14.09</u>	<u>4.77</u>	<u>14.85</u>	<u>5.24</u>	<u>15.58</u>	<u>5.70</u>
	5900	12.60	4.42	12.96	4.64	13.65	5.09	<u>14.33</u>	<u>5.57</u>	<u>15.01</u>	<u>6.07</u>	<u>15.70</u>	<u>6.58</u>	<u>16.38</u>	<u>7.10</u>

LEGEND

ESP — External Static Pressure

Bold indicates field-supplied drive or motor is required.

Plain type indicates standard motor and standard drive.

Underline indicates a different motor and drive combination other than the standard motor and standard drive combination is required. Refer to fan motor and drive tables to complete selection.

NOTES:

Maximum allowable fan speed is 18.3 r/s for unit sizes 028 and 030; 20 r/s for all other sizes. Fan performance is based on deductions for wet coil, clean 51-mm filters, and unit casing. See table below for factory-supplied filter pressure drop. For 60 Hz units, the medium-static drive and standard motor combination is not available for 028 size.

PERFORMANCE DATA (CONT.)

FAN PERFORMANCE DATA — FAS 350-600 Pa ESP — 60 Hz, SI

UNIT FAS	AIRFLOW (L/s)	EXTERNAL STATIC PRESSURE (Pa)											
		350		400		450		500		550		600	
		r/s	kW	r/s	kW	r/s	kW	r/s	kW	r/s	kW	r/s	kW
072	850	15.34	0.80	16.25	0.92	17.10	1.03	17.90	1.16	18.66	1.28	19.39	1.41
	990	15.69	0.94	16.61	1.07	17.47	1.20	18.28	1.33	19.04	1.47	19.77	1.61
	1130	16.04	1.09	16.95	1.23	17.81	1.38	18.63	1.53	19.40	1.67	—	—
	1270	16.44	1.27	17.32	1.42	18.17	1.58	18.97	1.74	19.75	1.90	—	—
	1420	16.91	1.49	17.75	1.64	18.56	1.81	19.34	1.97	—	—	—	—
091	1060	15.50	0.96	16.43	1.10	17.31	1.23	18.14	1.37	18.93	1.51	19.68	1.66
	1230	15.84	1.14	16.75	1.28	17.62	1.43	18.45	1.58	19.24	1.74	—	—
	1420	16.34	1.38	17.19	1.54	18.01	1.70	18.81	1.86	19.59	2.03	—	—
	1600	16.97	1.69	17.76	1.85	18.52	2.02	19.27	2.19	—	—	—	—
	1770	17.61	2.01	18.35	2.18	19.07	2.35	19.77	2.53	—	—	—	—
120	1420	16.02	1.33	16.87	1.48	17.71	1.64	18.52	1.80	19.30	1.97	—	—
	1650	16.76	1.70	17.53	1.85	18.29	2.02	19.04	2.19	19.77	2.37	—	—
	1890	17.64	2.16	18.35	2.33	19.05	2.51	19.74	2.69	—	—	—	—
	2120	18.60	2.73	19.28	2.91	19.93	3.10	—	—	—	—	—	—
	2360	19.61	3.40	—	—	—	—	—	—	—	—	—	—
150	1770	15.21	1.78	16.19	2.06	17.13	2.34	18.04	2.64	18.91	2.94	19.75	3.25
	2030	15.46	2.05	16.37	2.33	17.26	2.63	18.12	2.94	18.96	3.26	19.78	3.59
	2360	15.94	2.46	16.78	2.77	17.60	3.08	18.40	3.40	19.18	3.73	19.94	4.07
	2690	16.51	2.95	17.32	3.28	18.09	3.62	18.84	3.96	19.57	4.31	—	—
	2950	16.99	3.39	17.78	3.74	18.54	4.10	19.26	4.47	19.96	4.84	—	—
180	2120	15.21	2.05	16.11	2.33	16.98	2.62	17.83	2.93	18.66	3.24	19.47	3.57
	2500	15.69	2.49	16.54	2.80	17.35	3.12	18.14	3.44	18.90	3.77	19.64	4.11
	2830	16.18	2.94	17.01	3.28	17.79	3.63	18.54	3.97	19.27	4.33	19.97	4.69
	3210	16.75	3.52	17.57	3.90	18.34	4.29	19.08	4.67	19.78	5.06	—	—
	3540	17.26	4.09	18.07	4.50	18.84	4.93	19.57	5.35	—	—	—	—
240	2830	16.01	2.88	16.85	3.22	17.64	3.56	18.39	3.91	19.12	4.26	—	—
	3300	16.67	3.57	17.50	3.96	18.28	4.36	19.03	4.75	19.73	5.15	—	—
	3780	17.35	4.39	18.17	4.82	18.95	5.27	19.68	5.72	—	—	—	—
	4250	18.11	5.37	18.88	5.83	19.63	6.31	—	—	—	—	—	—
	4720	18.96	6.58	19.67	7.05	—	—	—	—	—	—	—	—
300	3540	14.57	3.97	14.95	4.41	15.67	5.07	16.50	5.59	—	—	—	—
	4130	14.76	3.99	15.51	4.57	16.36	5.46	17.00	6.04	—	—	—	—
	4720	15.49	4.92	16.15	5.37	16.78	5.88	17.42	6.50	—	—	—	—
	5310	16.26	6.15	16.91	6.61	17.51	7.08	18.10	7.58	—	—	—	—
	5900	17.04	7.61	17.68	8.11	18.28	8.62	—	—	—	—	—	—

LEGEND

ESP — External Static Pressure

Bold indicates field-supplied drive or motor is required.

Plain type indicates standard motor and standard drive.

Underline indicates a different motor and drive combination other than the standard motor and standard drive combination is required. Refer to fan motor and drive tables to complete selection.

NOTES:

Maximum allowable fan speed is 18.3 r/s for unit sizes 028 and 030; 20 r/s for all other sizes. Fan performance is based on deductions for wet coil, clean 51-mm filters, and unit casing. See table below for factory-supplied filter pressure drop. For 60 Hz units, the medium-static drive and standard motor combination is not available for 028 size.

PERFORMANCE DATA (CONT.)

DUCT SOUND POWER LEVELS (L_w)

MODEL	SIZE	CFM	dB(A)	OCTAVE BAND CENTER FREQUENCY (Hz)						
				63	125	250	500	1000	2000	4000
FAS	072	2,400	86.3	93.2	89.2	85.2	84.2	80.2	78.2	74.2
	091	3,000	88.3	95.3	91.3	87.3	86.3	82.3	80.3	76.3
	120	4,000	91.6	98.6	94.6	90.6	89.6	85.6	83.6	79.6
	150	5,000	91.1	97.3	93.3	89.3	90.3	84.3	82.3	78.3
	180	6,000	92.7	98.9	94.9	90.9	91.9	85.9	83.9	79.9

LEGEND:

ASHRAE – American Society of Heating, Refrigerating and Air Conditioning, Inc.

HVAC – Heating, Ventilation and Air Conditioning

NOTES:

1. The above estimated sound power levels are based upon the ASHRAE calculation approach from the ASHRAE 1987 HVAC Systems and Applications handbook, Chapter 52.
2. Since this data is calculated, these sound power levels may be different than the actual sound power levels.
3. The acoustic center of the unit is located at the geometric center of the unit.

FACTORY-SUPPLIED FILTER PRESSURE DROP — English

SIZE	UNIT	AIRFLOW (Cfm)	PRESSURE DROP (in. wg)
072	FAS	1,800	0.05
		2,400	0.08
		3,000	0.11
091	FAS	2,250	0.07
		3,000	0.11
		3,750	0.15
120	FAS	3,000	0.11
		4,000	0.17
		5,000	0.23
150	FAS	3,750	0.06
		5,000	0.10
		6,250	0.13
180	FAS	4,500	0.08
		6,000	0.12
		7,500	0.17
240	FAS	6,000	0.12
		8,000	0.19
		10,000	0.26
300	FAS	7,500	0.15
		10,000	0.22
		12,500	0.30

FACTORY-SUPPLIED FILTER PRESSURE DROP — SI

SIZE	UNIT	AIRFLOW (L/s)	PRESSURE DROP (Pa)
072	FAS	850	13
		1150	20
		1450	28
091	FAS	1000	17
		1400	27
		1800	38
120	FAS	1450	28
		1900	42
		2350	56
150	FAS	1750	15
		2350	24
		2950	33
180	FAS	2100	20
		2800	30
		3500	42
240	FAS	2900	32
		3800	47
		4700	64
300	FAS	3500	36
		4700	55
		5900	76

PERFORMANCE DATA (CONT.)

ACCESSORY PLENUM AIR THROW DATA — English (Ft)

UNIT	AIRFLOW (Cfm)	VANE DEFLECTION		
		Straight	21°	45°
FAS072	2,400	39	33	24
FAS091	3,000	45	38	28
FAS120	4,000	55	46	33
FAS150	5,000	45	38	28
FAS180	6,000	50	43	31
FAS240	8,000	60	51	37
FAS300	10,000	76	65	47

NOTE: Throw distances shown are for 75 fpm terminal velocity. Use the following multipliers to determine throw values for other terminal velocities.

TERMINAL VELOCITY (Fpm)	THROW FACTOR
50	X 1.50
100	X 0.75
150	X 0.50

ACCESSORY PLENUM AIR THROW DATA — SI(m)

UNIT	AIRFLOW (L/s)	VANE DEFLECTION		
		Straight	21°	45°
FAS072	1150	11.71	9.91	7.20
FAS091	1400	13.87	11.71	8.63
FAS120	1900	16.65	13.93	9.99
FAS150	2350	13.77	11.63	8.57
FAS180	2800	15.41	13.25	9.55
FAS240	3800	18.17	15.44	11.20
FAS300	4700	23.26	19.89	14.38

NOTE: Throw distances shown are for 0.381 m/sec terminal velocity. Use the following multipliers to determine throw values for other terminal velocities.

TERMINAL VELOCITY (m/sec)	THROW FACTOR
0.254	X 1.50
0.508	X 0.75
0.762	X 0.50

PERFORMANCE DATA (CONT.)

ACCESSORY PRESSURE DROP — English (in. wg)

UNIT	AIRFLOW (Cfm)	DISCHARGE PLENUM	RETURN AIR GRILLE	Hot Water	Steam	Electric	ECONOMIZER
FAS072	1,800	0.06	0.01	0.10	0.10	0.04	0.05
	2,400	0.10	0.01	0.16	0.16	0.06	0.07
	3,000	0.14	0.02	0.23	0.23	0.10	0.09
FAS091	2,250	0.09	0.01	0.15	0.15	0.06	0.06
	3,000	0.14	0.02	0.23	0.23	0.10	0.09
	3,750	0.21	0.03	0.35	0.35	0.15	0.15
FAS120	3,000	0.14	0.02	0.23	0.23	0.10	0.09
	4,000	0.22	0.04	0.37	0.37	0.17	0.17
	5,000	0.32	0.06	0.53	0.53	0.26	0.28
FAS150	3,750	0.07	0.01	0.11	0.11	0.04	0.05
	5,000	0.12	0.02	0.17	0.17	0.07	0.07
	6,250	0.17	0.02	0.25	0.25	0.11	0.11
FAS180	4,500	0.10	0.01	0.15	0.15	0.06	0.06
	6,000	0.16	0.02	0.23	0.23	0.10	0.09
	7,500	0.23	0.03	0.33	0.33	0.15	0.15
FAS240	6,000	0.16	0.02	0.23	0.23	0.10	0.09
	8,000	0.26	0.04	0.37	0.37	0.17	0.17
	10,000	0.37	0.06	0.53	0.53	0.26	0.28
FAS300	7,500	0.15	0.02	0.28	0.28	0.09	0.06
	10,000	0.24	0.03	0.44	0.44	0.16	0.09
	12,500	0.34	0.05	0.63	0.63	0.24	0.14

ACCESSORY PRESSURE DROP — SI (Pa)

UNIT	AIRFLOW (L/s)	DISCHARGE PLENUM	RETURN AIR GRILLE	HEATING COILS			ECONOMIZER
				Hot Water	Steam	Electric	
FAS072	850	15	2	25	25	9	12
	1150	25	3	41	41	16	18
	1450	36	5	60	60	26	23
FAS091	1000	20	2	33	33	12	13
	1400	34	5	57	57	24	22
	1800	51	8	85	85	39	39
FAS120	1450	36	5	60	60	26	23
	1900	56	10	93	93	43	43
	2350	79	15	132	132	65	69
FAS150	1750	18	2	26	26	10	12
	2350	29	5	43	43	17	17
	2950	43	5	62	62	26	27
FAS180	2100	24	2	36	36	14	15
	2800	39	5	57	57	24	22
	3500	56	7	82	82	37	37
FAS240	2900	41	5	60	60	26	23
	3800	64	10	93	93	43	43
	4700	91	15	132	132	65	69
FAS300	3500	37	5	67	67	22	15
	4700	59	7	109	109	39	22
	5900	86	12	157	157	60	35

ELECTRICAL DATA

STANDARD MOTORS

UNIT	V*-PH-Hz	VOLTAGE LIMITS	FAN MOTOR		POWER SUPPLY	
			Hp (kW)	FLA	Minimum Circuit Amps	MOCP
FAS072	208/230-1-60	187-253	1.3 (0.97)	7.6	9.5	15
	208/230-3-60	187-253	2.4 (1.79)	5.8	7.5	15
	460-3-60	414-506	2.4 (1.79)	2.6	3.3	15
	575-3-60	518-632	1.0 (0.75)	1.4	1.7	15
FAS091	208/230-1-60	187-253	2.4 (1.79)	11.0	13.8	20
	208/230-3-60	187-253	2.4 (1.79)	5.8	6.5	15
	460-3-60	414-506	2.4 (1.79)	2.6	3.3	15
	575-3-60	518-632	2.0 (1.49)	2.4	3.0	15
FAS120	208/230-3-60	187-253	2.4 (1.79)	5.8	7.3	15
	460-3-60	414-506	2.4 (1.79)	2.6	3.3	15
	575-3-60	518-632	2.0 (1.49)	2.4	3.0	15
FAS150	208/230-3-60	187-253	2.4 (1.79)	5.8	7.5	15
	460-3-60	414-506	2.4 (1.79)	2.6	3.3	15
	575-3-60	518-632	3.0 (2.24)	3.8	4.8	15
FAS180	208/230-3-60	187-253	3.7 (2.76)	10.6	13.3	20
	460-3-60	414-506	3.7 (2.76)	4.8	6.0	15
	575-3-60	518-632	3.0 (2.24)	3.8	4.8	15
FAS240	208/230-3-60	187-253	5.0 (3.73)	14.7/13.6	18.4/17.0	30/25
	460-3-60	414-506	5.0 (3.73)	6.8	8.5	15
	575-3-60	518-632	5.0 (3.73)	5.1	6.4	15
FAS300	208/230-3-60	187-253	7.5 (5.59)	21.5/19.4	26.9/24.3	45/40
	460-3-60	414-506	7.5 (5.59)	9.7	12.1	20
	575-3-60	518-632	7.5 (5.59)	7.8	9.8	15

LEGEND

FLA — Full Load Amps

MOCP — Maximum Overcurrent Protection

* Motors are designed for satisfactory operation within 10% of nominal voltages shown. Voltages should not exceed the limits shown in the Voltage Limits column.

NOTES:

1. Minimum circuit amps (MCA) and MOCP values are calculated in accordance with NEC (National Electrical Code) (U.S.A. standard), Article 440.
2. Motor FLA values are established in accordance with UL (Underwriters' Laboratories) Standard 1995 (U.S.A. standard).
3. Indoor fan motors 5 hp and larger meet the minimum efficiency requirements as established by the Energy Policy Act of 1992 (EPACT) effective October 24, 1997.
4. Unbalanced 3-Phase Supply Voltage
Never operate a motor where a phase imbalance in supply voltage is greater than 2%. Use the following formula to determine the percentage of voltage imbalance.

$$\% \text{ Voltage Imbalance} = 100 \times \frac{\text{max voltage deviation from average voltage}}{\text{average voltage}}$$

Example: Supply voltage is 230-3-60



AB = 224 v
BC = 231 v
AC = 226 v

$$\begin{aligned} \text{Average Voltage} &= \frac{(224 + 231 + 226)}{3} = \frac{681}{3} \\ &= 227 \end{aligned}$$

Determine maximum deviation from average voltage.

(AB) 227 - 224 = 3 v

(BC) 231 - 227 = 4 v

(AC) 227 - 226 = 1 v

Maximum deviation is 4 v.

Determine percent of voltage imbalance.

$$\begin{aligned} \% \text{ Voltage Imbalance} &= 100 \times \frac{4}{227} \\ &= 1.76\% \end{aligned}$$

This amount of phase imbalance is satisfactory as it is below the maximum allowable 2%.

IMPORTANT: If the supply voltage phase imbalance is more than 2%, contact your local electric utility company immediately.



ELECTRICAL DATA (CONT.)

ALTERNATE MOTORS

UNIT	V*-PH-Hz	VOLTAGE LIMITS	FAN MOTOR		POWER SUPPLY	
			Hp (kW)	FLA	Minimum Circuit Amps	MOCP
FAS072	208/230-1-60	187-253	2.4 (1.79)	11.0	13.8	20
	208/230-3-60	187-253	2.9 (2.16)	7.5	9.4	15
	460-3-60	414-506	2.9 (2.16)	3.4	4.3	15
	575-3-60	518-632	2.0 (1.49)	2.3	2.9	15
FAS091	208/230-1-60	187-253	2.4 (1.79)	11.0	13.8	15
	208/230-3-60	187-253	2.9 (2.16)	7.5	9.4	15
	460-3-60	414-506	2.9 (2.16)	3.4	4.3	15
	575-3-60	518-632	3.0 (2.24)	3.8	4.8	15
FAS120	208/230-3-60	187-253	3.7 (2.76)	10.2	12.8	20
	460-3-60	414-506	3.7 (2.76)	4.8	6.0	15
	575-3-60	518-632	3.0 (2.24)	3.8	4.8	15
FAS150	208/230-3-60	187-253	3.7 (2.76)	10.2	12.7	20
	460-3-60	414-506	3.7 (2.76)	4.8	6.0	15
	575-3-60	518-632	5.0 (3.73)	5.1	6.4	15
FAS180	208/230-3-60	187-253	5.0 (3.73)	14.6/13.6	18.4/17.0	30/25
	460-3-60	414-506	5.0 (3.73)	6.8	6.0	15
	575-3-60	518-632	5.0 (3.73)	5.1	6.4	15
FAS240	208/230-3-60	187-253	7.5 (5.59)	21.5/19.4	26.9/24.3	45/40
	460-3-60	414-506	7.5 (5.59)	9.7	12.1	20
	575-3-60	518-632	7.5 (5.59)	7.8	9.8	15
FAS300	208/230-3-60	187-253	10.0 (7.46)	28.2/25.2	35.0/31.5	60/60
	460-3-60	414-506	10.0 (7.46)	12.6	15.8	30
	575-3-60	518-632	10.0 (7.46)	10.3	12.9	20

LEGEND

FLA — Full Load Amps

MOCP — Maximum Overcurrent Protection

* Motors are designed for satisfactory operation within 10% of nominal voltages shown. Voltages should not exceed the limits shown in the Voltage Limits column.

NOTES:

1. Minimum circuit amps (MCA) and MOCP values are calculated in accordance with NEC (National Electrical Code) (U.S.A. standard), Article 440.
2. Motor FLA values are established in accordance with UL (Underwriters' Laboratories) Standard 1995 (U.S.A. standard).
3. Indoor fan motors 5 hp and larger meet the minimum efficiency requirements as established by the Energy Policy Act of 1992 (EPACT) effective October 24, 1997.
4. Unbalanced 3-Phase Supply Voltage
Never operate a motor where a phase imbalance in supply voltage is greater than 2%. Use the following formula to determine the percentage of voltage imbalance.

$$\% \text{ Voltage Imbalance} = 100 \times \frac{\text{max voltage deviation from average voltage}}{\text{average voltage}}$$

Example: Supply voltage is 230-3-60



AB = 224 v
BC = 231 v
AC = 226 v

$$\begin{aligned} \text{Average Voltage} &= \frac{(224 + 231 + 226)}{3} = \frac{681}{3} \\ &= 227 \end{aligned}$$

Determine maximum deviation from average voltage.

(AB) 227 - 224 = 3 v

(BC) 231 - 227 = 4 v

(AC) 227 - 226 = 1 v

Maximum deviation is 4 v.

Determine percent of voltage imbalance.

$$\begin{aligned} \% \text{ Voltage Imbalance} &= 100 \times \frac{4}{227} \\ &= 1.76\% \end{aligned}$$

This amount of phase imbalance is satisfactory as it is below the maximum allowable 2%.

IMPORTANT: If the supply voltage phase imbalance is more than 2%, contact your local electric utility company immediately.



ELECTRICAL DATA (CONT.)

ELECTRIC HEATER DATA

HEATER PART NO.	Unit FAS	V-PH-Hz	FAN MOTOR			ELECTRIC HEATER(S)					MCA*	MOCP*	
			Hp	kW	FLA	Nominal Capacity (kW)	Actual Capacity (kW)			FLA			
							Stage 1	Stage 2	Total				
AAHC05AHA	072-120	208-3-60	1.3†	0.97	7.6	5	3.8	—	3.8	10.4	22.5	25	
			2.4†	1.79	11.0	5	3.8	—	3.8	10.4	26.8	35	
			2.4	1.79	5.2	5	3.8	—	3.8	10.4	19.5	20	
			2.9	2.16	7.5	5	3.8	—	3.8	10.4	22.4	25	
			3.7	2.76	10.2	5	3.8	—	3.8	10.4	25.8	30	
		240-3-60	1.3†	0.97	7.6	5	5.0	—	5.0	12.0	24.5	25	
			2.4†	1.79	11.0	5	5.0	—	5.0	12.0	28.8	35	
			2.4	1.79	5.2	5	5.0	—	5.0	12.0	21.5	25	
			2.9	2.16	7.5	5	5.0	—	5.0	12.0	24.4	25	
			3.7	2.76	10.2	5	5.0	—	5.0	12.0	27.8	30	
		AAHC05ALA	480-3-60	2.4	1.79	2.6	5	5.0	—	5.0	6.00	10.8	15
				2.9	2.16	3.4	5	5.0	—	5.0	6.00	11.8	15
				3.7	2.76	4.8	5	5.0	—	5.0	6.00	13.5	15
		AAHC05ASA	575-3-60	1.0	0.75	1.4	5	5.0	—	5.0	5.00	8.0	15
				2.0	1.49	2.3	5	5.0	—	5.0	5.00	9.2	15
3.0	2.24			3.8	5	5.0	—	5.0	5.00	11.0	15		
AAHC10AHA	072-120	208-3-60	1.3†	0.97	7.6	10	7.5	—	7.5	20.8	35.6	40	
			2.4†	1.79	11.0	10	7.5	—	7.5	20.8	39.8	40	
			2.4	1.79	5.2	10	7.5	—	7.5	20.8	32.6	35	
			2.9	2.16	7.5	10	7.5	—	7.5	20.8	35.4	40	
			3.7	2.76	10.2	10	7.5	—	7.5	20.8	38.8	40	
		240-3-60	1.3†	0.97	7.6	10	10.0	—	10.0	24.1	39.6	40	
			2.4†	1.79	11.0	10	10.0	—	10.0	24.1	43.8	50	
			2.4	1.79	5.2	10	10.0	—	10.0	24.1	36.6	40	
			2.9	2.16	7.5	10	10.0	—	10.0	24.1	39.4	40	
			3.7	2.76	10.2	10	10.0	—	10.0	24.1	42.8	50	
		AAHC10ALA	480-3-60	2.4	1.79	2.6	10	10.0	—	10.0	12.0	18.3	20
				2.9	2.16	3.4	10	10.0	—	10.0	12.0	19.3	20
				3.7	2.76	4.8	10	10.0	—	10.0	12.0	21.0	25
		AAHC10ASA	575-3-60	1.0	0.75	1.4	10	10.0	—	10.0	10.0	14.3	15
				2.0	1.49	2.3	10	10.0	—	10.0	10.0	15.4	20
3.0	2.24			3.8	10	10.0	—	10.0	10.0	17.3	20		
AAHC15AHA	072-120	208-3-60	1.3†	0.97	7.6	15	11.3	—	11.3	31.3	48.6	50	
			2.4†	1.79	11.0	15	11.3	—	11.3	31.3	52.9	60	
			2.4	1.79	5.2	15	11.3	—	11.3	31.3	45.6	50	
			2.9	2.16	7.5	15	11.3	—	11.3	31.3	48.5	50	
			3.7	2.76	10.2	15	11.3	—	11.3	31.3	51.9	60	
		240-3-60	1.3†	0.97	7.6	15	15.0	—	15.0	36.1	54.6	60	
			2.4†	1.79	11.0	15	15.0	—	15.0	36.1	58.9	60	
			2.4	1.79	5.2	15	15.0	—	15.0	36.1	51.6	60	
			2.9	2.16	7.5	15	15.0	—	15.0	36.1	54.5	60	
			3.7	2.76	10.2	15	15.0	—	15.0	36.1	57.9	60	

LEGEND

FLA — Full Load Amps

Hp — Horsepower

MCA — Minimum Circuit Amps

MOCP — Maximum Overcurrent Protection (Amps)

* Values shown are for single-point connection of electric heat accessory and air handler.

† Single-phase motors. All other motors are 3-phase.

NOTES:

- Electrical resistance heaters are rated at 240 v, 480 v, or 575 v. To determine heater capacity (kW) at unit nameplate multiply the 240-v, 480-v, or 575-v capacity (kW) by the factor shown in the table below for the unit voltage.

HEATER RATING VOLTAGE	ACTUAL HEATER VOLTAGE										
	200	208	230	240	400	440	460	480	550	575	600
240	0.694	0.751	0.918	1	—	—	—	—	—	—	—
480	—	—	—	—	0.694	0.84	0.918	1	—	—	—
575	—	—	—	—	—	—	—	—	0.915	1	1.089

- The following equation converts kW of heat energy to Btuh:
kW x 3,412 = Btuh.

- Heater contactor coils are 24 v and require 8 va holding current.

- Electric heaters are tested and ETL approved at maximum total external static pressure of 1.9 in. wg.

- MCA and MOCP values apply to both standard and alternate factory-supplied motors.

- Approximate shipping weight for heaters that fit 6 to 10 ton units is 55 lb (25 kg) each. Approximate shipping weight for heaters that fit 12.5 to 15 ton units is 60 lb (27 kg) each.



ELECTRICAL DATA (cont.)

ELECTRIC HEATER DATA (cont)

HEATER PART NO.	Unit FAS	V-PH-Hz	FAN MOTOR			ELECTRIC HEATER(S)					MCA*	MOCP*		
			Hp	kW	FLA	Nominal Capacity (kW)	Actual Capacity (kW)			FLA				
							Stage 1	Stage 2	Total					
AAHC15ALA		480-3-60	2.4	1.79	2.6	15	15.0	—	15.0	18.0	25.8	30		
			2.9	2.16	3.4	15	15.0	—	15.0	18.0	26.8	30		
			3.7	2.76	4.8	15	15.0	—	15.0	18.0	28.6	30		
AAHC15ASA		575-3-60	1.0	0.75	1.4	15	15.0	—	15.0	15.1	20.6	25		
			2.0	1.49	2.3	15	15.0	—	15.0	15.1	21.7	25		
			3.0	2.24	3.8	15	15.0	—	15.0	15.1	23.6	25		
AAHC25AHA	072-120	208-3-60	1.3†	0.97	7.6	25	11.3	7.5	18.8	52.1	74.7	80		
			2.4†	1.79	11.0	25	11.3	7.5	18.8	52.1	78.9	80		
			2.4	1.79	5.2	25	11.3	7.5	18.8	52.1	71.7	80		
			2.9	2.16	7.5	25	11.3	7.5	18.8	52.1	74.5	80		
			3.7	2.76	10.2	25	11.3	7.5	18.8	52.1	77.9	80		
			2.4	1.79	5.2	25	11.3	7.5	18.8	52.1	71.7	80		
		240-3-60	1.3†	0.97	7.6	25	15.0	10.0	25.0	60.1	84.7	90		
			2.4†	1.79	11.0	25	15.0	10.0	25.0	60.1	88.9	90		
			2.4	1.79	5.2	25	15.0	10.0	25.0	60.1	81.7	90		
			2.9	2.16	7.5	25	15.0	10.0	25.0	60.1	84.6	90		
			3.7	2.76	10.2	25	15.0	10.0	25.0	60.1	87.9	90		
			2.4	1.79	5.2	25	15.0	10.0	25.0	60.1	81.7	90		
AAHC25ALA		480-3-60	2.4	1.79	2.6	25	15.0	10.0	25.0	30.1	40.8	50		
			2.9	2.16	3.4	25	15.0	10.0	25.0	30.1	41.8	50		
			3.7	2.76	4.8	25	15.0	10.0	25.0	30.1	43.6	50		
AAHC25ASA		575-3-60	1.0	0.75	1.4	25	15.0	10.0	25.0	25.1	33.1	35		
			2.0	1.49	2.3	25	15.0	10.0	25.0	25.1	34.3	35		
			3.0	2.24	3.8	25	15.0	10.0	25.0	25.1	36.1	40		
AAHC35CHA	091, 120	208-3-60	2.4†	1.79	11.0	35	15.0	11.3	26.3	73.0	105.0	110		
			2.4	1.79	5.2	35	15.0	11.3	26.3	73.0	97.7	100		
			2.9	2.16	7.5	35	15.0	11.3	26.3	73.0	100.6	110		
			3.7	2.76	10.2	35	15.0	11.3	26.3	73.0	104.0	110		
		240-3-60	2.4†	1.79	11.0	35	20.0	15.0	35.0	84.2	119.0	125		
			2.4	1.79	5.2	35	20.0	15.0	35.0	84.2	111.7	125		
			2.9	2.16	7.5	35	20.0	15.0	35.0	84.2	114.6	125		
			3.7	2.76	10.2	35	20.0	15.0	35.0	84.2	118.0	125		
		AAHC35CLA		480-3-60	2.4	1.79	2.6	35	20.0	15.0	35.0	42.1	55.9	60
					2.9	2.16	3.4	35	20.0	15.0	35.0	42.1	56.9	60
					3.7	2.76	4.8	35	20.0	15.0	35.0	42.1	58.6	60
		AAHC35CSA		575-3-60	2.0	1.49	2.3	35	20.0	15.0	35.0	35.1	46.8	50
3.0	2.24				3.8	35	20.0	15.0	35.0	35.1	48.7	50		

LEGEND

FLA — Full Load Amps

Hp — Horsepower

MCA — Minimum Circuit Amps

MOCP — Maximum Overcurrent Protection (Amps)

* Values shown are for single-point connection of electric heat accessory and air handler.

† Single-phase motors. All other motors are 3-phase.

NOTES:

- Electrical resistance heaters are rated at 240 v, 480 v, or 575 v. To determine heater capacity (kW) at unit nameplate multiply the 240-v, 480-v, or 575-v capacity (kW) by the factor shown in the table below for the unit voltage.

- The following equation converts kW of heat energy to Btuh:

$$\text{kW} \times 3,412 = \text{Btuh}$$

- Heater contactor coils are 24 v and require 8 va holding current.
- Electric heaters are tested and ETL approved at maximum total external static pressure of 1.9 in. wg.
- MCA and MOCP values apply to both standard and alternate factory-supplied motors.
- Approximate shipping weight for heaters that fit 6 to 10 ton units is 55 lb (25 kg) each. Approximate shipping weight for heaters that fit 12.5 to 15 ton units is 60 lb (27 kg) each.

HEATER RATING VOLTAGE	ACTUAL HEATER VOLTAGE										
	200	208	230	240	400	440	460	480	550	575	600
240	0.694	0.751	0.918	1	—	—	—	—	—	—	—
480	—	—	—	—	0.694	0.84	0.918	1	—	—	—
575	—	—	—	—	—	—	—	—	0.915	1	1.089



ELECTRICAL DATA (cont.)

ELECTRIC HEATER DATA (cont)

HEATER PART NO.	Unit FAS	V-PH-Hz	FAN MOTOR			ELECTRIC HEATER(S)						
						Nominal Capacity (kW)	Actual Capacity (kW)			FLA	MCA*	MOCP*
			Hp	kW	FLA		Stage 1	Stage 2	Total			
AAHC10BHA		208-3-60	2.9	2.16	7.5	10	7.5	—	7.5	20.8	35.4	40
			3.7	2.76	10.2	10	7.5	—	7.5	20.8	38.8	40
			5.0	3.73	14.7	10	7.5	—	7.5	20.8	44.4	50
AAHC10BLA		480-3-60	2.9	2.16	3.4	10	10.0	—	10.0	12.0	19.3	20
			3.7	2.76	4.8	10	10.0	—	10.0	12.0	21.0	25
			5.0	3.73	6.8	10	10.0	—	10.0	12.0	23.5	25
AAHC10BSA		575-3-60	3.0	2.24	3.8	10	10.0	—	10.0	10.0	17.3	20
			5.0	3.73	5.1	10	10.0	—	10.0	10.0	19.6	20
			2.9	2.16	7.5	20	14.9	—	14.9	41.5	51.2	70
AAHC20BHA	150, 180, 240	208-3-60	3.7	2.76	10.2	20	14.9	—	14.9	41.5	64.6	70
			5.0	3.73	14.7	20	14.9	—	14.9	41.5	70.2	80
			2.9	2.16	7.5	20	19.9	—	19.9	47.9	69.2	70
AAHC20BLA		480-3-60	3.7	2.76	10.2	20	19.9	—	19.9	47.9	72.6	80
			5.0	3.73	13.6	20	19.9	—	19.9	47.9	76.8	80
			2.9	2.16	3.4	20	20.0	—	20.0	24.1	34.3	35
AAHC20BSA		575-3-60	3.7	2.76	4.8	20	20.0	—	20.0	24.1	36.1	40
			5.0	3.73	6.8	20	20.0	—	20.0	24.1	38.6	40
			3.0	2.24	3.8	20	20.0	—	20.0	20.1	29.9	30
AAHC30BHA		208-3-60	5.0	3.73	5.1	20	20.0	—	20.0	20.1	31.5	35
			2.9	2.16	7.5	30	15.0	7.5	22.5	62.5	87.5	90
			3.7	2.76	10.2	30	15.0	7.5	22.5	62.5	90.9	100
AAHC30BLA		480-3-60	5.0	3.73	13.6	30	15.0	7.5	22.5	62.5	96.5	100
			2.9	2.16	7.5	30	20.0	10.0	30.0	72.2	99.6	100
			3.7	2.76	10.2	30	20.0	10.0	30.0	72.2	103.0	110
AAHC30BSA		575-3-60	5.0	3.73	13.6	30	20.0	10.0	30.0	72.2	107.2	110
			2.9	2.16	3.4	30	20.0	10.0	30.0	36.1	49.4	50
			3.7	2.76	4.8	30	20.0	10.0	30.0	36.1	51.1	60
AAHC30BHA		208-3-60	5.0	3.73	6.8	30	20.0	10.0	30.0	36.1	53.6	60
			3.0	2.24	3.8	30	20.0	10.0	30.0	30.1	42.4	50
			5.0	3.73	5.1	30	20.0	10.0	30.0	30.1	44.0	50

LEGEND

FLA — Full Load Amps

Hp — Horsepower

MCA — Minimum Circuit Amps

MOCP — Maximum Overcurrent Protection (Amps)

* Values shown are for single-point connection of electric heat accessory and air handler.

† Single-phase motors. All other motors are 3-phase.

NOTES:

- Electrical resistance heaters are rated at 240 v, 480 v, or 575 v. To determine heater capacity (kW) at unit nameplate multiply the 240-v, 480-v, or 575-v capacity (kW) by the factor shown in the table below for the unit voltage.

HEATER RATING VOLTAGE	ACTUAL HEATER VOLTAGE										
	200	208	230	240	400	440	460	480	550	575	600
240	0.694	0.751	0.918	1	—	—	—	—	—	—	—
480	—	—	—	—	0.694	0.84	0.918	1	—	—	—
575	—	—	—	—	—	—	—	—	0.915	1	1.089

- The following equation converts kW of heat energy to Btuh:
kW x 3,412 = Btuh.

- Heater contactor coils are 24 v and require 8 va holding current.

- Electric heaters are tested and ETL approved at maximum total external static pressure of 1.9 in. wg.

- MCA and MOCP values apply to both standard and alternate factory-supplied motors.

- Approximate shipping weight for heaters that fit 6 to 10 ton units is 55 lb (25 kg) each. Approximate shipping weight for heaters that fit 12.5 to 20 ton units is 60 lb (27 kg) each.



ELECTRICAL DATA (CONT.)

ELECTRIC HEATER DATA (cont.)

HEATER PART NO.	SIZE	V-PH-Hz	FAN MOTOR			ELECTRIC HEATER(S)					MCA*	MOCP*	
			Hp	kW	FLA	Nominal Capacity (kW)	Actual Capacity (kW)			FLA			
							Stage 1	Stage 2	Total				
AAHC50DHA	FAS180-240	208-3-60	3.7	2.76	10.2	50	22.6	15.0	37.6	104.3	143.1	150	
			5.0	3.73	14.7	50	22.6	15.0	37.6	104.3	148.7	150	
			7.5	5.59	21.5	50	22.6	15.0	37.6	104.3	157.2	175	
		240-3-60	3.7	2.76	10.2	50	30.0	20.0	50.0	120.3	163.1	175	
			5.0	3.73	13.6	50	30.0	20.0	50.0	120.3	167.4	175	
			7.5	5.59	19.4	50	30.0	20.0	50.0	120.3	174.6	175	
		AAHC50DLA	480-3-60	3.7	2.76	4.8	50	30.0	20.0	50.0	60.1	81.2	90
				5.0	3.73	6.8	50	30.0	20.0	50.0	60.1	83.7	90
				7.5	5.59	9.7	50	30.0	20.0	50.0	60.1	87.3	90
AAHC50DSA	575-3-60	3.0	2.24	3.8	50	30.0	20.0	50.0	50.2	67.5	70		
		5.0	3.73	5.1	50	30.0	20.0	50.0	50.2	69.1	70		
		7.5	5.59	7.8	50	30.0	20.0	50.0	50.2	72.5	80		
AAHC20EHA	FAS300	208-3-60	7.5	5.59	21.5	20	14.9	—	14.9	41.5	78.7	80	
			10.0	7.46	28.0	20	14.9	—	14.9	41.5	86.9	100	
		240-3-60	7.5	5.59	19.4	20	19.9	—	19.9	47.9	84.1	90	
			10.0	7.46	25.2	20	19.9	—	19.9	47.9	91.3	100	
		480-3-60	7.5	5.59	9.7	20	20.0	—	20.0	24.1	42.2	50	
			10.0	7.46	12.6	20	20.0	—	20.0	24.1	45.8	50	
AAHC20ELA	575-3-60	7.5	5.59	7.8	20	20.0	—	20.0	20.1	34.9	35		
		10.0	7.46	10.3	20	20.0	—	20.0	20.1	38.0	40		
AAHC20ESA	208-3-60	7.5	5.59	21.5	40	15.0	15.0	30.0	83.4	131.1	150		
		10.0	7.46	28.0	40	15.0	15.0	30.0	83.4	139.2	150		
		7.5	5.59	19.4	40	20.0	20.0	40.0	96.2	144.5	150		
		10.0	7.46	25.2	40	20.0	20.0	40.0	96.2	151.8	175		
AAHC40EHA	240-3-60	7.5	5.59	9.7	40	20.0	20.0	40.0	47.9	71.9	80		
		10.0	7.46	12.6	40	20.0	20.0	40.0	47.9	75.6	80		
AAHC40ELA	480-3-60	7.5	5.59	7.8	40	20.0	20.0	40.0	40.2	60.0	60		
		10.0	7.46	10.3	40	20.0	20.0	40.0	40.2	63.1	70		
AAHC40ESA	575-3-60	7.5	5.59	7.8	40	20.0	20.0	40.0	40.2	60.0	60		
		10.0	7.46	10.3	40	20.0	20.0	40.0	40.2	63.1	70		

LEGEND

- FLA** — Full Load Amps
- Hp** — Horsepower
- MCA** — Minimum Circuit Amps
- MOCP** — Maximum Overcurrent Protection (Amps)

* Values shown are for single-point connection of electric heat accessory and air handler.

† Single-phase motors. All other motors are 3-phase.

NOTES:

1. Electrical resistance heaters are rated at 240 v, 480 v, or 575 v. To determine heater capacity (kW) at unit nameplate multiply the 240-v, 480-v, or 575-v capacity (kW) by the factor shown in the table below for the unit voltage.

HEATER RATING VOLTAGE	ACTUAL HEATER VOLTAGE										
	200	208	230	240	400	440	460	480	550	575	600
240	0.694	0.751	0.918	1	—	—	—	—	—	—	—
480	—	—	—	—	0.694	0.84	0.918	1	—	—	—
575	—	—	—	—	—	—	—	—	0.915	1	1.089

2. The following equation converts kW of heat energy to Btuh: $kW \times 3,412 = Btuh$.
3. Heater contactor coils are 24 v and require 8 va holding current.
4. Electric heaters are tested and ETL approved at maximum total external static pressure of 1.9 in. wg.
5. MCA and MOCP values apply to both standard and alternate factory-supplied motors.
6. Approximate shipping weight for heaters that fit 6 to 10 ton units is 55 lb (25 kg) each. Approximate shipping weight for heaters that fit 12.5 to 20 ton units is 60 lb (27 kg) each.



TYPICAL PIPING AND WIRING

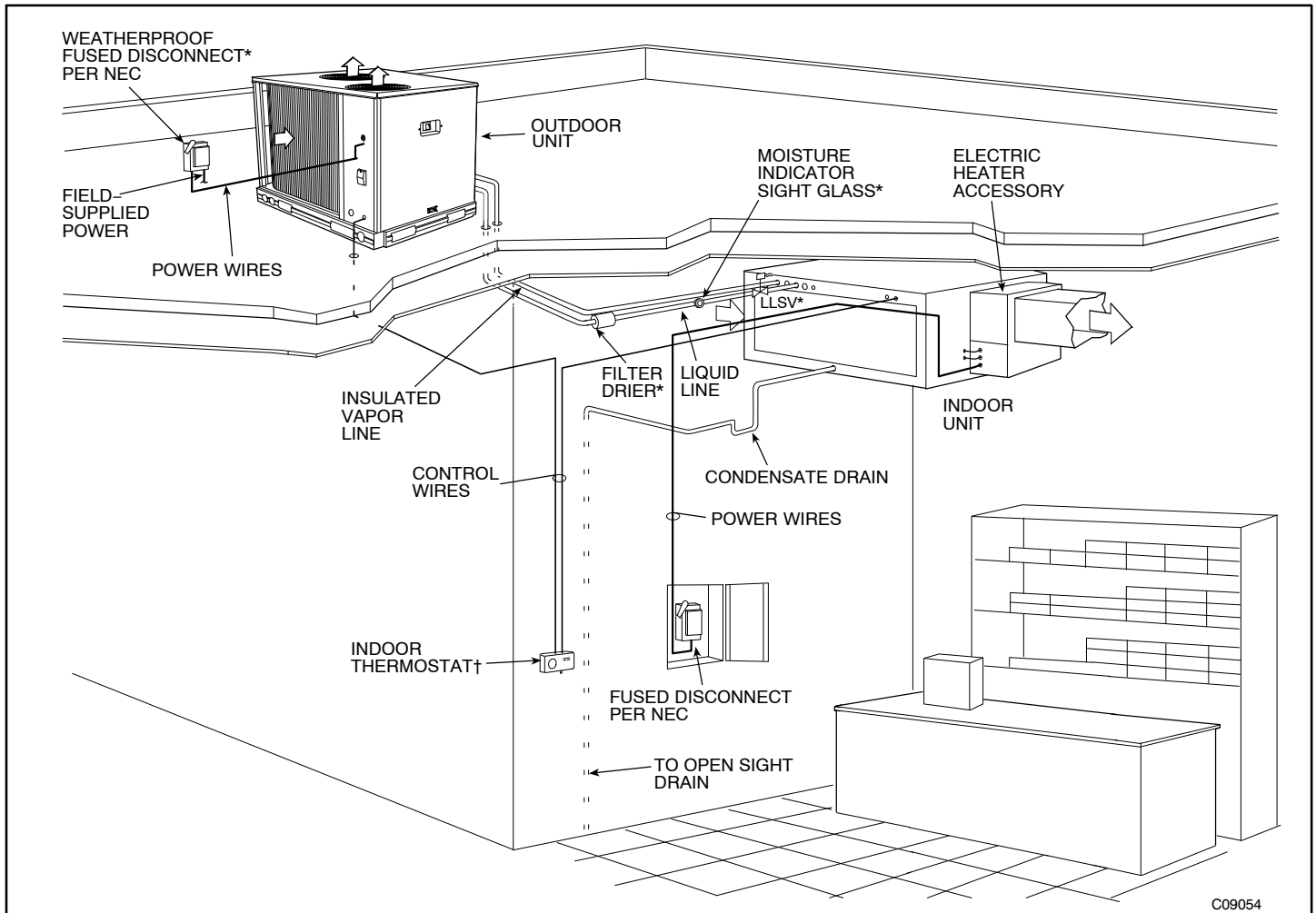

C09054

LEGEND:

NEC — National Electrical Code

TXV — Thermostatic Expansion Valve

* Field-supplied

† Double riser may be required. Consult condensing unit product data catalog for details.

NOTES:

1. All piping must follow standard refrigerant piping techniques.
2. All wiring must comply with the applicable local and national codes.
3. Wiring and piping shown are general points-of-connection guides only and are not intended for, or to include all details for, a specific installation.
4. Liquid line solenoid valve (solenoid drop control) is recommended to prevent refrigerant migration to the compressor.
5. Internal factory-supplied TXVs not shown.

TYPICAL PIPING AND WIRING (cont.)

VERTICAL INSTALLATION – FAS (TYPICAL)

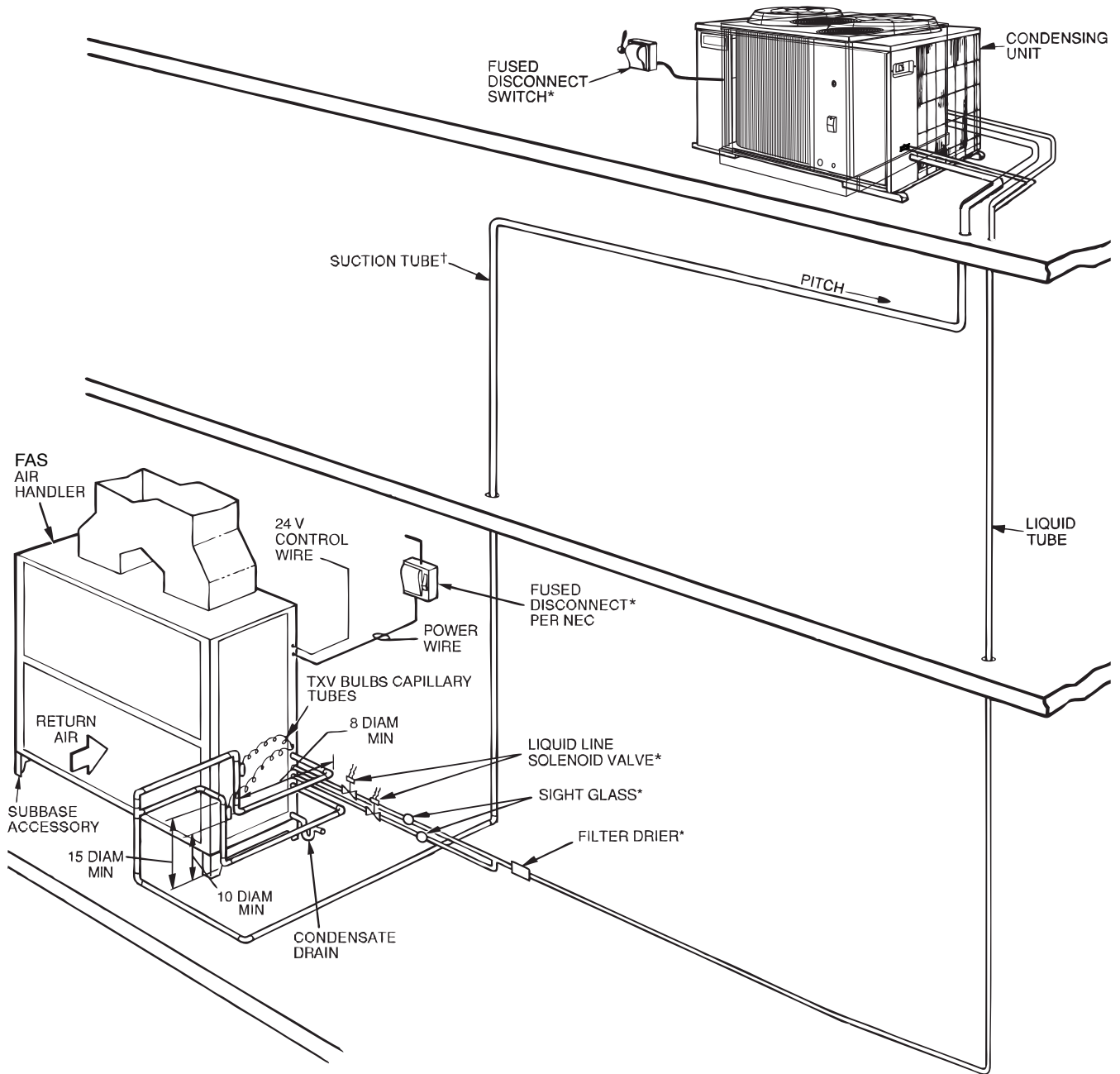

C09055

LEGEND:

LLSV – Liquid Line Solenoid Valve

NEC – National Electrical Code

TXV – Thermostatic Expansion Valve

* Field-supplied

† Double riser may be required Consult condensing unit product data catalog for details.

NOTES:

1. All piping must follow standard refrigerant piping techniques.
2. All wiring must comply with the applicable local and national codes.
3. Wiring and piping shown are general points-of-connection guides only and are not intended for, or to include all details for, a specific installation.
4. Liquid line solenoid valve (solenoid drop control) is recommended to prevent refrigerant migration to the compressor.
5. Internal factory-supplied TXVs not shown.

TYPICAL PIPING AND WIRING (cont.)

WIRING ROUTING, BASE UNIT FAS

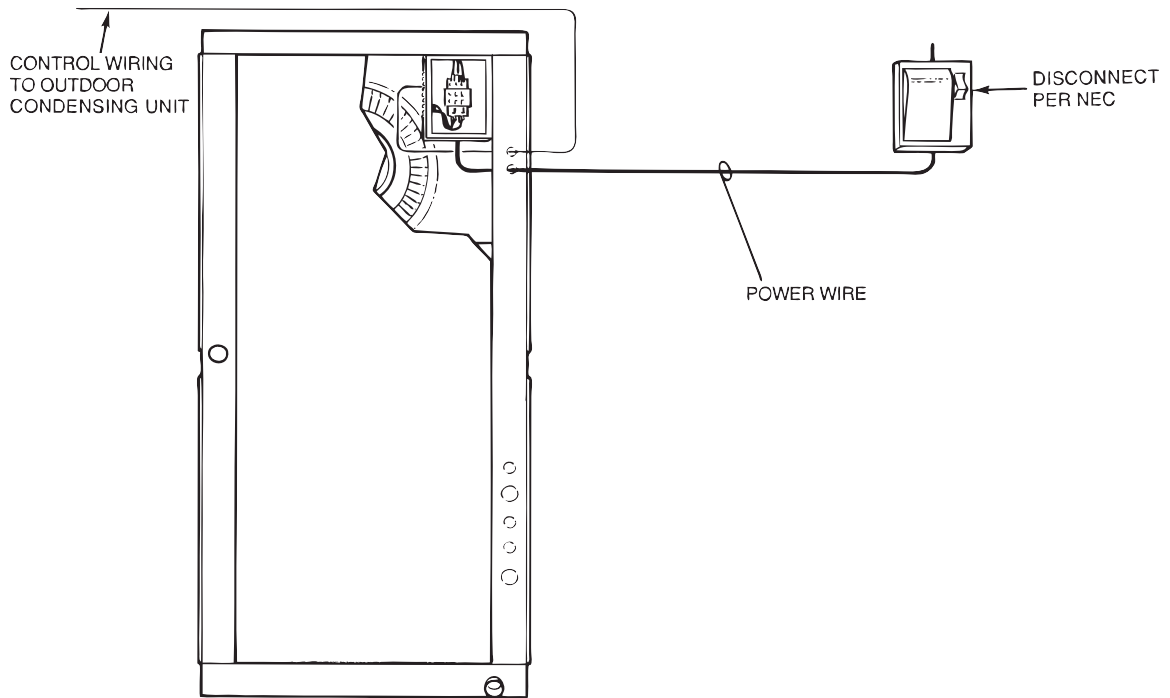

WIRING ROUTING, UNIT WITH ELECTRIC HEAT - FAS

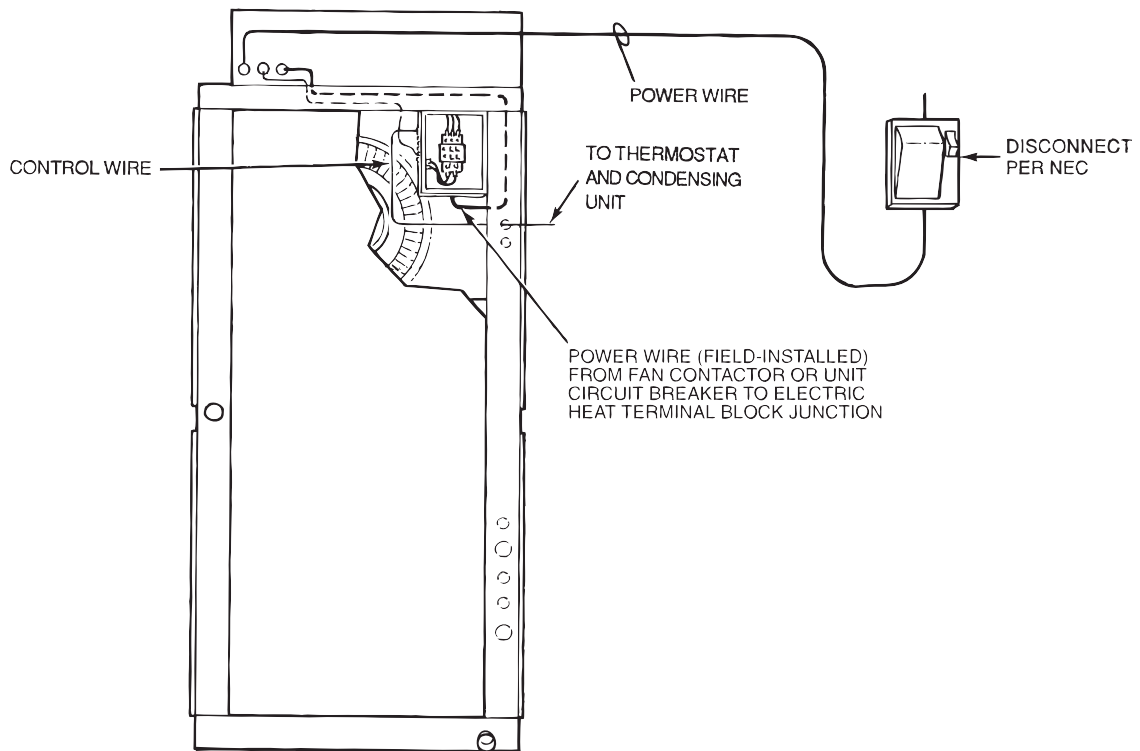

TYPICAL CONTROL WIRING SCHEMATIC

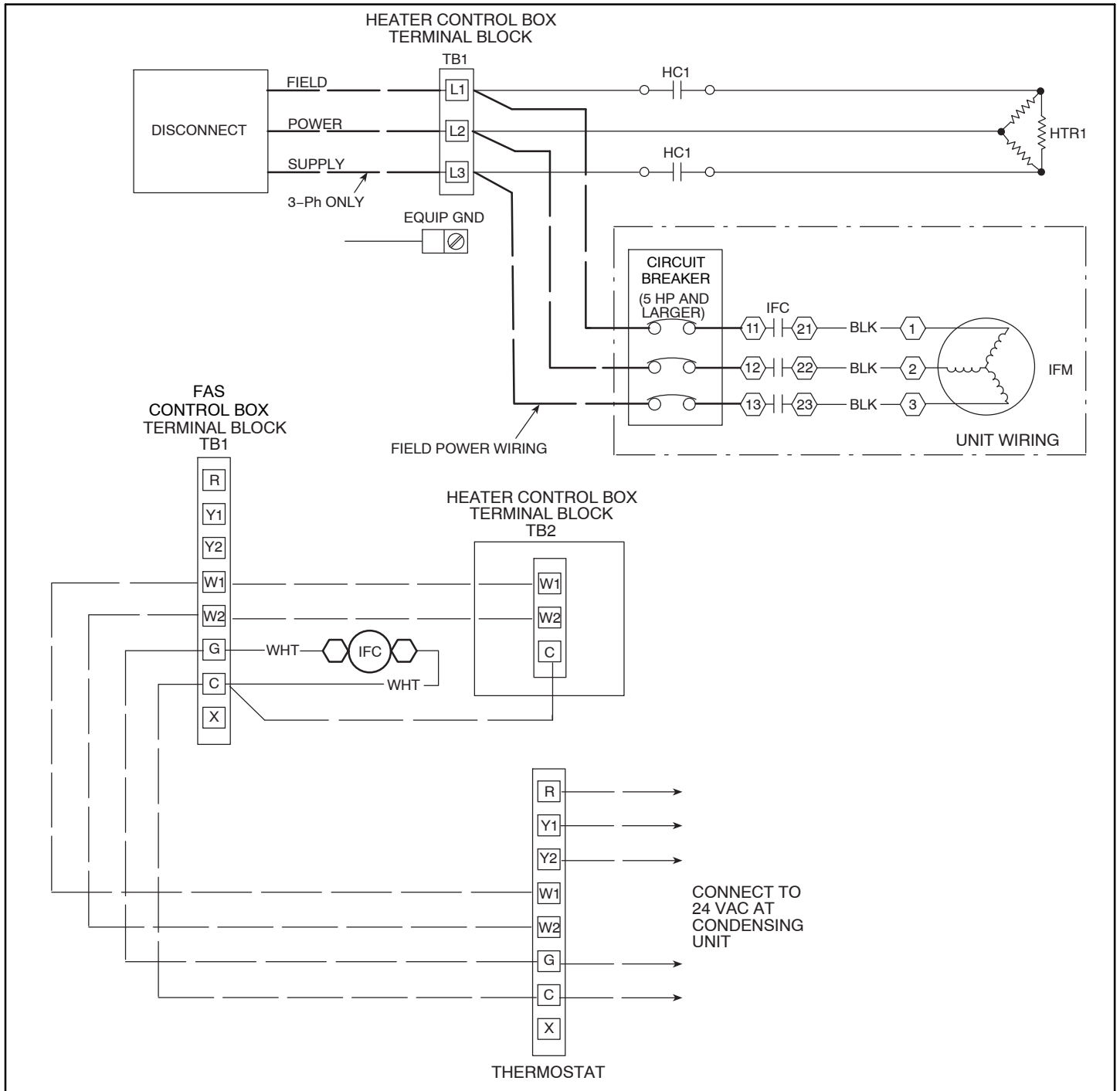

C09050

APPLICATION DATA

Operating limits

Maximum fan speed

FAS072-150 1200 RPM(20 R/S)

General

IMPORTANT: Do not bury refrigerant piping underground.

Select equipment to match or to be slightly less than peak load. This provides better humidity control, less unit cycling, and less part-load operation. Equipment should be selected to perform at no less than 300 cfm/ton (40 L/s per kW).

The air handler fan must always be operating when the condensing unit is operating.

Ductwork should be sized according to unit size, not building load. For larger units with two fans, a split duct

transition is recommended at the fan outlets, but a plenum can be used with slight reduction in external static pressure capability.

For variable air volume (VAV) systems with supply-to-return air recycling, use the equipment room as a return air plenum.

Hot gas bypass

Hot gas bypass may be required for low load control in certain applications. Hot gas should only be used during first stage cooling operation and should be applied to all evaporator circuits that are active at that time. To apply hot gas bypass, the FAS unit will require a field-installed auxiliary side connector(s). See the Auxiliary Side Connector Data table for part numbers.

AUXILIARY SIDE CONNECTOR DATA

UNIT FAS	P/N	INLET/OUTLET DIAMETER — ODF (in.)	AUXILIARY (Hot Gas) DIAMETER — ODF (in.)
072	1178747	1 ¹ / ₈	5 ⁵ / ₈
091	1178748	1 ³ / ₈	7 ⁷ / ₈
120	1178747	1 ¹ / ₈	5 ⁵ / ₈
150	1178747	1 ¹ / ₈	5 ⁵ / ₈
180	1178747	1 ¹ / ₈	5 ⁵ / ₈
240	1178747	1 ¹ / ₈	5 ⁵ / ₈
300	1178748	1 ³ / ₈	7 ⁷ / ₈

FACTORY-INSTALLED NOZZLE AND DISTRIBUTOR DATA

UNIT	COIL TYPE	TXV Qty...Part No.*	DISTRIBUTOR Qty...Part No.†	FEEDER TUBES PER DISTRIBUTOR Qty...Size (in.)	NOZZLE Qty...Part No.
072	4 Row	1...TDEBX8	1...1116	12... ¹ / ₄	1...E5
091	4 Row	1...TDEBX8	1...1126	15... ¹ / ₄	1...C6
120	4 Row	2...TDEX6	2...1115	9... ¹ / ₄	2...E4
150	4 Row	2...TDEBX8	2...1115	12... ³ / ₁₆	2...E5
180	4 Row	2...TDEBX8	2...1126	16... ¹ / ₄	2...C6
240	4 Row	2...TDEBX11	2...1126	18... ³ / ₁₆	2...C8
300	4 Row	2...TDEBX11	2...1126	20... ³ / ₁₆	2...C15

LEGEND

TXV — Thermostatic Expansion Valve

* Danfoss part numbers shown.

† Sporlan Valve Co. part numbers shown.

NOTE: Hot gas bypass applications require field-supplied auxiliary side connector.

APPLICATION DATA (cont.)

FAN MOTOR DATA STANDARD MOTOR — U.S.

UNIT	FAS072	FAS091	FAS120	FAS150	FAS180	FAS240	FAS300
208/230-1-60							
Speed (rpm)	1725	1725	—	—	—	—	—
Hp	1.3	2.4	—	—	—	—	—
Frame (NEMA)	56Y	56Y	—	—	—	—	—
Shaft Dia (in.)	5/8	5/8	—	—	—	—	—
208/230-3-60 and 460-3-60							
Speed (rpm)	1725	1725	1725	1725	1725	1745	1745
Hp	2.4	2.4	2.4	2.9	3.7	5.0	7.5
Frame (NEMA)	56Y	56Y	56Y	56Y	56Y	S184T	S213T
Shaft Dia (in.)	5/8	5/8	5/8	7/8	7/8	1 1/8	1 3/8
575-3-60							
Speed (rpm)	1725	1725	1725	1725	1725	1745	1755
Hp	1.0	2.0	2.0	3.0	3.0	5.0	7.5
Frame (NEMA)	56	56HZ	56HZ	56HZ	56HZ	184T	S213T
Shaft Dia (in.)	5/8	7/8	7/8	7/8	7/8	1 1/8	1 3/8

LEGEND:

NEMA — National Electrical Manufacturers Association (U.S.A.)

HIGH STATIC MOTOR — U.S.

UNIT	FAS072	FAS091	FAS120	FAS150	FAS180	FAS240	FAS300
208/230-1-60							
Speed (rpm)	1725	1725	—	—	—	—	—
Hp	2.4	2.4	—	—	—	—	—
Frame (NEMA)	56Y	56Y	—	—	—	—	—
Shaft Dia (in.)	5/8	5/8	—	—	—	—	—
230-3-60 and 460-3-60							
Speed (rpm)	1725	1725	1725	1725	1725	1745	1745
Hp	2.9	2.9	3.7	3.7	5.0	7.5	10.0
Frame (NEMA)	56Y	56Y	Y56Y	Y56Y	S184T	S213T	S215T
Shaft Dia (in.)	7/8	7/8	7/8	7/8	1 1/8	1 3/8	1 3/8
575-3-60							
Speed (rpm)	1725	1725	1725	1745	1745	1755	1750
Hp	2.0	3.0	3.0	5.0	5.0	7.5	10.0
Frame (NEMA)	56HZ	56HZ	56HZ	184T	184T	S213T	D215T
Shaft Dia (in.)	7/8	7/8	7/8	1 1/8	1 1/8	1 3/8	1 3/8

LEGEND:

NEMA — National Electrical Manufacturers Association (U.S.A.)

MOTOR EFFICIENCY FAS

MOTOR HP	EPACT MINIMUM	MOTOR EFFICIENCY
1.3*	—	70%
2.4	—	82%
2.9	—	82%
3.7	—	84%
5.0	89.5%	89.5%
7.5	91.7%	91.7%
10.0	91.7%	91.7%

LEGEND:

EPACT — Energy Policy and Conservation Act of 1992

* Single-phase only.

APPLICATION DATA (cont.)

FAN MOTOR DATA (cont) STANDARD MOTOR — SI

UNIT	FAS072	FAS091	FAS120	FAS150	FAS180	FAS240	FAS300
208/230-1-60							
Speed (r/s)	28.75	28.75	—	—	—	—	—
Shaft kW	0.97	1.79	—	—	—	—	—
Frame (NEMA)	56Y	56Y	—	—	—	—	—
Shaft Dia (mm)	15.9	15.9	—	—	—	—	—
208/230-3-60 and 460-3-60							
Speed (r/s)	28.75	28.75	28.75	28.75	28.75	29.08	29.08
Shaft kW	1.79	1.79	1.79	2.16	2.76	3.73	5.60
Frame (NEMA)	56Y	56Y	56Y	56Y	56Y	S184T	S213T
Shaft Dia (mm)	15.9	15.9	15.9	22.2	22.2	28.6	34.9
575-3-60							
Speed(r/s)	28.75	28.75	28.75	28.75	28.75	29.08	29.25
Shaft kW	0.75	1.49	1.49	2.24	2.24	3.73	5.60
Frame (NEMA)	56	56HZ	56HZ	56HZ	56HZ	184T	S213T
Shaft Dia (mm)	15.9	22.2	22.2	22.2	22.2	28.6	34.9

LEGEND:

NEMA — National Electrical Manufacturers Association (U.S.A.)

HIGH STATIC MOTOR — SI

UNIT	FAS072	FAS091	FAS120	FAS150	FAS180	FAS240	FAS300
208/230-1-60							
Speed (r/s)	28.75	28.75	—	—	—	—	—
Shaft kW	1.79	1.79	—	—	—	—	—
Frame (NEMA)	56Y	56Y	—	—	—	—	—
Shaft Dia (mm)	15.9	15.9	—	—	—	—	—
208/230-3-60 and 460-3-60							
Speed(r/s)	28.75	28.75	28.75	28.75	29.08	29.08	29.17
Shaft kW	2.16	2.16	2.76	2.76	3.73	5.60	7.46
Frame (NEMA)	56Y	56Y	Y56Y	Y56Y	S184T	S213T	S215T
Shaft Dia (mm)	22.2	22.2	22.2	22.2	28.6	34.9	34.9
575-3-60							
Speed (r/s)	28.75	28.75	28.75	29.08	29.08	29.25	29.17
Shaft kW	1.50	2.24	2.24	3.73	3.73	5.60	7.46
Frame (NEMA)	56HZ	56HZ	56HZ	184T	184T	S213T	D215T
Shaft Dia (mm)	22.2	22.2	22.2	28.6	28.6	34.9	34.9

LEGEND:

NEMA — National Electrical Manufacturers Association (U.S.A.)

APPLICATION DATA (cont.)

STANDARD DRIVE DATA, 60 Hz — U.S.

UNIT	FAS072	FAS091	FAS120	FAS150	FAS180	FAS240	FAS300
MOTOR DRIVE							
Motor Pulley Pitch Diameter (in.)	2.4-3.4	2.8-3.8	3.4-4.4	2.8-3.8	2.8-3.8	3.7-4.7	4.3-5.3
Pulley Factory Setting Full Turns Open	2.5	2.5	2.5	2.5	2.5	3.0	3.0
FAN DRIVE							
Pulley Pitch Dia (in.)	8.8	8.8	8.8	9.0	9.0	9.4	11.0
Pulley Bore (in.)	1	1	1	1 ^{7/16}	1 ^{7/16}	1 ^{7/16}	1 ^{15/16}
Belt No. — Section	1—A	1—A	1—A	1—A	1—A	1—B	2—B*
Belt Pitch (in.)	40.3	41.3	42.3	42.3	42.3	41.8	(2) 42.8 (2) 43.8
FAN SPEEDS (rpm)							
Factory Settings	568	647	764	632	632	771	752
Range	470-666	549-745	666-863	537-728	537-728	679-863	682-841
Max Allowable Speed (rpm)	1200	1200	1200	1200	1200	1200	1100
Change per 1/2 turn of Moveable Motor Pulley Flange	19.6	19.6	19.7	19.1	19.1	15.3	13.1
MAX FULL TURNS FROM CLOSED POSITION	5	5	5	5	5	6	6
SHAFTS CENTER DISTANCE (in.)	10.44- 12.32	10.44- 12.32	10.44- 12.32	10.44- 12.32	10.44- 12.32	9.12- 10.99	6.67- 9.43

* Four belts shipped with unit. Use correct set of 2 belts sized according to the pulley setting.

MEDIUM-STATIC DRIVE DATA, 60 Hz — U.S.

UNIT	FAS072	FAS091	FAS120	FAS150	FAS180	FAS240	FAS300
MOTOR DRIVE							
Motor Pulley Pitch Diameter (in.)	3.4-4.4	3.4-4.4	3.4-4.4	3.4-4.4	3.7-4.7	4.3-5.3	4.3-5.3
Pulley Factory Setting Full Turns Open	2.5	2.5	2.5	2.5	3.0	3.0	3.0
FAN DRIVE							
Pulley Pitch Dia (in.)	8.8	8.0	8.0	8.2	8.6	9.4	9.4
Pulley Bore (in.)	1	1	1	1 ^{7/16}	1 ^{7/16}	1 ^{7/16}	1 ^{15/16}
Belt No. — Section	1—A	1—A	1—A	1—A	1—B	1—B	2—B*
Belt Pitch (in.)	42.3	40.3	40.3	41.3	41.8	41.8	(2) 38.8 (2) 39.8
FAN SPEEDS (rpm)							
Factory Setting	764	841	841	820	842	881	881
Range	666-863	733-949	733-949	715-926	742-943	798-984	798-984
Max Allowable Speed (rpm)	1200	1200	1200	1200	1200	1200	1100
Change per 1/2 Turn of Moveable Motor Pulley Flange	19.7	21.6	21.6	21.1	16.7	15.3	15.3
MAX FULL TURNS FROM CLOSED POSITION	5	5	5	5	6	6	6
SHAFTS CENTER DISTANCE (in.)	10.44- 12.32	10.44- 12.32	10.44- 12.32	10.44- 12.32	10.44- 12.32	9.16- 10.99	6.67- 9.43

* Four belts shipped with unit. Use correct set of 2 belts sized according to the pulley setting.

APPLICATION DATA (cont.)

HIGH-STATIC DRIVE DATA, 60 Hz — U.S.

UNIT	FAS072	FAS091	FAS120	FAS150	FAS180	FAS240	FAS300
MOTOR DRIVE							
Motor Pulley Pitch Diameter (in.)	3.4-4.4	3.4-4.4	3.4-4.4	3.7-4.7	4.3-5.3	4.3-5.3	4.3-5.3
Pulley Factory Setting Full Turns Open	2.5	2.5	2.5	3.0	3.0	3.0	3.0
FAN DRIVE							
Pulley Pitch Dia (in.)	7.0	6.0*	6.0	7.4	7.9	7.4	8.6
Pulley Bore (in.)	1	1	1	1 ⁷ / ₁₆	1 ⁷ / ₁₆	1 ⁷ / ₁₆	1 ¹⁵ / ₁₆
Belt No. — Section	1—A	1—A	1—A	1—B	1—B	2—B	2—B
Belt Pitch (in.)	41.3	37.3	37.3	39.8	39.8	36.8	37.8
FAN SPEEDS (rpm)							
Factory Setting	961	1121	1121	979	1060	1118	1024
Range	838- 1084	978- 1200*†	978- 1200†	873- 1096	950- 1171	1014- 1200†	873- 1075
Max Allowable Speed (rpm)	1200	1200	1200	1200	1200	1200	1100
Change per 1/2 Turn of Moveable Motor Pulley Flange	24.6	28.7	28.7	19.4	18.4	19.4	16.7
MAX FULL TURNS FROM CLOSED POSITION	5	5	5	6	6	6	6
SHAFTS CENTER DISTANCE (in.)	10.44- 12.32	10.44- 12.32	10.44- 12.32	10.44- 12.32**	9.16- 10.99	8.16- 10.02	6.67- 9.43

* Values for 3-phase motor shown. For single-phase motor, pulley pitch diameter is 7 in. and resulting fan speed is 837-1096 rpm.

† It is possible to adjust drive so that fan speed exceeds maximum allowable. DO NOT exceed 1200 rpm.

** 575-v unit has a center distance of 9.16-10.99.

STANDARD DRIVE DATA, 60 Hz — SI

UNIT	FAS072	FAS091	FAS120	FAS150	FAS180	FAS240	FAS300
MOTOR DRIVE							
Motor Pulley Pitch Diameter (mm)	61.0- 86.4	71.1- 96.5	86.4- 111.8	71.1- 96.5	71.1- 96.5	94.0- 119.4	109.2- 134.6
Pulley Factory Setting Full Turns Open	2.5	2.5	2.5	2.5	2.5	3.0	3.0
FAN DRIVE							
Pulley Pitch Dia (mm)	224	224	224	229	229	239	279
Pulley Bore (mm)	25.4	25.4	25.4	36.5	36.5	36.5	49.2
Belt No. — Section	1—A	1—A	1—A	1—A	1—A	1—B	2—B*
Belt Pitch (mm)	1024	1049	1074	1074	1074	1062	(2) 1087 (2) 1113
FAN SPEEDS (r/s)							
Factory Setting	9.5	10.8	12.7	10.5	10.5	12.9	12.5
Range	7.8-11.1	9.2-12.4	11.1-14.4	9.0-12.1	9.0-12.1	11.3-14.4	11.4-14.0
Max Allowable Speed (r/s)	20.0	20.0	20.0	20.0	20.0	20.0	18.3
Change per 1/2 Turn of Moveable Motor Pulley Flange	0.327	0.327	0.328	0.318	0.318	0.255	0.218
MAX FULL TURNS FROM CLOSED POSITION	5	5	5	5	5	6	6
SHAFTS CENTER DISTANCE (mm)	265-313	265-313	265-313	265-313	265-313	232-279	169-240

* Four belts shipped with unit. Use correct set of 2 belts sized according to the pulley setting.

APPLICATION DATA (cont.)

MEDIUM-STATIC DRIVE DATA, 60 Hz — SI

UNIT	FAS072	FAS091	FAS120	FAS150	FAS180	FAS240	FAS300
MOTOR DRIVE							
Motor Pulley Pitch Diameter (mm)	86.4-111.8	86.4-111.8	86.4-111.8	86.4-111.8	94.0-119.4	109.2-134.6	109.2-134.6
Pulley Factory Setting Full Turns Open	2.5	2.5	2.5	2.5	3.0	3.0	3.0
FAN DRIVE							
Pulley Pitch Dia (mm)	224	203	203	208	218	239	239
Pulley Bore (mm)	25.4	25.4	25.4	36.5	36.5	36.5	49.2
Belt No. — Section	1—A	1—A	1—A	1—A	1—B	1—B	2—B*
Belt Pitch (mm)	1074	1024	1024	1049	1062	1062	(2) 986 (2) 1011
FAN SPEEDS (r/s)							
Factory Setting	12.7	14.0	14.0	13.7	14.0	14.7	14.7
Range	11.1-14.4	12.2-15.8	12.2-15.8	11.9-15.4	12.4-15.7	13.3-16.4	13.3-16.4
Max Allowable Speed (r/s)	20.0	20.0	20.0	20.0	20.0	20.0	18.3
Change per 1/2 Turn of Moveable Motor Pulley Flange	0.328	0.360	0.360	0.352	0.278	0.255	0.255
MAX FULL TURNS FROM CLOSED POSITION							
	5	5	5	6	6	6	6
SHAFTS CENTER DISTANCE (mm)	265-313	265-313	265-313	265-313	265-313	232-279	169-240

* Four belts shipped with unit. Use correct set of 2 belts sized according to the pulley setting.

HIGH-STATIC DRIVE DATA, 60 Hz — SI

UNIT	FAS072	FAS091	FAS120	FAS150	FAS180	FAS240	FAS300
MOTOR DRIVE							
Motor Pulley Pitch Diameter (mm)	86.4-111.8	86.4-111.8	86.4-111.8	94.0-119.4	109.2-134.6	109.2-134.6	109.2-134.6
Pulley Factory Setting Full Turns Open	2.5	2.5	2.5	3.0	3.0	3.0	3.0
FAN DRIVE							
Pulley Pitch Dia (mm)	178	152*	152	188	201	188	203
Pulley Bore (mm)	25.4	25.4	25.4	36.5	36.5	36.5	49.2
Belt No. — Section	1—A	1—A	1—A	1—B	1—B	2—B	2—B
Belt Pitch (mm)	1049	947	947	1011	1011	935	935
FAN SPEEDS (r/s)							
Factory Setting	16.0	18.7	18.7	16.3	17.7	18.6	17.1
Range	14.0-18.1	16.3-20.0*†	16.3-20.0†	14.4-18.3	15.8-19.5	16.9-20.0†	14.6-17.9
Max Allowable Speed (r/s)	20.0	20.0	20.0	20.0	20.0	20.0	18.3
Change per 1/2 Turn of Moveable Motor Pulley Flange	0.410	0.478	0.478	0.323	0.307	0.323	0.278
MAX FULL TURNS FROM CLOSED POSITION							
	5	5	5	6	6	6	6
SHAFTS CENTER DISTANCE (mm)	265-313	265-313	265-313	265-313**	232-279	207-255	169-240

* Values for 3-phase motor shown. For single-phase motor, pulley pitch diameter is 178 mm and resulting fan speed is 14.0-18.3 r/s.

† It is possible to adjust drive so that fan speed exceeds maximum allowable. DO NOT exceed 20 r/s.

** 575-v unit has a center distance of 233-279.

GUIDE SPECIFICATIONS

Commercial Packaged Air-Handling Unit

HVAC Guide Specifications

Size Range: **2,400 to 10,000 Cfm (1133 to 4719 L/s), Nominal Airflow, 6 to 25 Tons (21 to 87 kW), Nominal Cooling**

Model Number: **FAS (Direct-Expansion Coil)**

Part 1 — GENERAL

1.01 SYSTEM DESCRIPTION

- A. Indoor, packaged air-handling unit for use in commercial split systems. Unit shall have a multi-position design and shall be capable of horizontal or vertical installation on a floor or in a ceiling, with or without ductwork. (Only vertical units are to be applied without ductwork.)
- B. Unit with direct-expansion coil shall be used in a refrigerant circuit with a matching air-cooled condensing unit. Unit with chilled water coil shall be used in a chilled water circuit.

1.02 QUALITY ASSURANCE

- A. Coils shall be designed and tested in accordance with ASHRAE 15 Safety Code for Mechanical Refrigeration (U.S.A.), latest edition.
- B. Unit shall be constructed in accordance with ETL (U.S.A.) and ETL, Canada, standards and shall carry the ETL and ETL, Canada, labels.
- C. Unit insulation and adhesive shall comply with NFPA-90A (U.S.A.) requirements for flame spread and smoke generation. Insulation shall contain an EPA-registered immobilized antimicrobial agent to effectively resist the growth of bacteria and fungi as proven by tests in accordance with ASTM standards G21 and 22 (U.S.A.).
- D. Unit shall be manufactured in a facility registered to the ISO 9001:2000 manufacturing quality standard.
- E. Direct-expansion and chilled water coils shall be burst and leak tested at 435 psi (2999 kPa).

1.03 DELIVERY AND STORAGE

Units shall be stored and handled per manufacturer's recommendations.

Part 2 — PRODUCTS

2.01 EQUIPMENT

Indoor mounted, draw-thru, packaged air-handling unit that can be used in a suspended horizontal configuration or a vertical configuration. Unit shall consist of forward-curved belt-driven centrifugal fan(s), motor and drive assembly, pre-wired fan motor contactor, factory-installed refrigerant metering devices (direct-expansion coil units), cooling coil, 2-in. (51-mm) disposable air filters, and

condensate drain pans for vertical or horizontal configurations.

A. Base Unit:

1. Cabinet shall be constructed of mill-galvanized steel.
2. Cabinet panels shall be fully insulated with 1/2-in. (12.7-mm) fire-retardant material. Insulation shall contain an EPA-registered immobilized antimicrobial agent to effectively resist the growth of bacteria and fungi as proven by tests in accordance with ASTM standards G21 and 22 (U.S.A.).
3. Unit shall contain non-corroding condensate drain pans for both vertical and horizontal applications. Drain pans shall have connections on right and left sides of unit to facilitate field connection. Drain pans shall have the ability to be sloped toward the right or left side of the unit to prevent standing water from accumulating in pans.
4. Unit shall have factory-supplied 2-in. (51 mm) throwaway-type filters installed upstream from the cooling coil. Filter access shall be from either the right or left side of the unit.

B. Coils:

DX coil is 4-row and consists of copper tubes with sine-wave aluminum fins bonded to the tubes by mechanical expansion. Suction and liquid line connections or supply and discharge connections shall be made on the same side of the coil.

1. Direct-expansion coils shall feature factory installed thermostatic expansion valves (TXVs) for refrigerant control. The TXVs shall be R-410A compatible and capable of external adjustment. Direct-expansion heat pump coils shall have a factory-installed bypass line and check valve assembly around the TXVs to allow liquid flow from the coil to the outdoor unit during the heating mode. Coil tubing shall be internally rifled to maximize heat transfer.

C. Operating Characteristics:

Unit shall be capable of providing _____ cfm (L/s) airflow at an external static pressure of _____ in. wg (kPag).

D. Motor:

1. Fan motor of the size and electrical characteristics specified on the equipment schedule shall be factory supplied and installed.

GUIDE SPECIFICATIONS (cont.)

2. Motors rated at 1.3 through 3.7 hp (0.97 through 2.76 kW) shall have internal thermal overload protection. Motors rated at 5 hp (3.73 kW) shall be protected by a circuit breaker.
3. Evaporator-fan motor shall have permanently lubricated, sealed bearings and inherent automatic-reset thermal overload protection or manual reset calibrated circuit breakers. Evaporator motors are designed specifically for our units and do not have conventional horsepower (hp) ratings listed on the motor nameplate. Motors are designed and qualified in the "air-over" location downstream of the cooling coil and carry a maximum continuous bhp rating that is the maximum application bhp rating for the motor; no "safety factors" above that rating may be applied.
4. All evaporator-fan motors 5 hp and larger shall meet the minimum efficiency requirements as established by the Energy Policy Act of 1992 (EPACT), effective October 24, 1997.

E. Special Features:

1. High Static Motor and Drive:

A high-static drive shall be available to meet the airflow and external static pressure requirements specified on the equipment schedule.

2. External Paint:

Where conditions require, units shall be painted with an American Sterling Gray finish.

3. Hot Water Coil:

Coil shall be 2-row, U-bend coil with copper tubes and aluminum plate fins bonded to the tubes by mechanical expansion. Coil shall be mounted in a galvanized steel housing that shall be fastened to the unit's fan deck for blow-thru heating operation. Coil shall have maximum working pressure of 150 psig (1034 kPag).

4. Steam Distributing Coil:

Coil shall consist of one row of copper tubes with aluminum plate fins, and shall have inner steam distributing tubes. Coil shall be mounted in a galvanized steel housing and shall be fastened to the unit's fan deck for blow-thru heating operation. Coil shall have maximum working pressure of 20 psig at 260°F (138 kPag at 126°C).

5. Electric Heaters:

Heaters for nominal 240, 480, or 575-volt, 3-phase, 60 Hz shall be factory-supplied for field installation as shown on the equipment drawings. Electric heat assembly shall be ETL (U.S.A.) and ETL, Canada, agency approved, and shall have single-point power wiring. Heater assembly shall include contactors with 24-v coils, power wiring, 24-v control wiring

terminal blocks, and a hinged access panel. Electric heaters shall not be used with air discharge plenum.

6. Air Discharge Plenum:

Plenum shall be factory-supplied to provide free-blow air distribution for vertical floor-mounted units. A grille with moveable vanes for horizontal or vertical airflow adjustment shall be included. Plenum shall be field-assembled and field-installed on the unit's fan deck for blow-thru air distribution. Plenum shall not be used with electric heaters.

7. Return-Air Grille:

Grille shall be factory-supplied for field installation on the unit's return air opening.

8. Unit Subbase:

Subbase assembly shall be factory-supplied for field installation. Subbase shall elevate floor-mounted vertical units to provide access for correct condensate drain connection.

9. Economizer:

Economizer for ventilation or "free" cooling shall be factory provided for field installation on either return air opening of air handler. For free cooling applications, economizer shall be compatible with separate thermostat; economizer dampers shall open when outdoor air enthalpy is suitable for free cooling. Economizer shall be compatible with separate CO₂ sensor accessory; economizer dampers shall open when indoor CO₂ level rises above predetermined set point. Economizer shall include enthalpy control and damper actuator.

10. Overhead Suspension Package:

Package shall include necessary brackets to support units in a horizontal ceiling installation.

11. CO₂ Sensor:

Sensor shall provide the ability to signal the economizer to open when the space CO₂ level exceeds the predetermined setpoint. Sensor shall have the capability of being connected to Comfort System relay pack or to economizer using field-supplied and field-installed Honeywell dc adapter no. Q769C1004.

12. Condensate Drain Trap:

Trap shall have transparent, serviceable design for easy cleaning. Kit shall include overflow shutoff switch and wiring harness for connection to an alarm if desired.