



2024 WATER HEATING PRODUCT CATALOG



 **ARISTON**
GROUP

TABLE OF CONTENTS

Electric Storage Water Heaters

EVERLAST Elevate Demand Response.....	2
EVERLAST Elevate.....	4
EVERLAST Demand Response.....	6
EVERLAST Residential.....	8
EVERLAST Grid Enabled.....	10
EVERLAST Mini Tank.....	12
EVERLAST Light Duty.....	14
EVERLAST Medium Duty.....	16

Gas Storage Water Heaters

Phoenix Light Duty.....	18
Phoenix & Phoenix Multifit.....	20
Phoenix Plus.....	22

Volume Water Heaters

Elite XL VWH.....	24
-------------------	----

Indirect Water Heaters

SuperStor Ultra Max.....	28
SuperStor Ultra	30
SuperStor Ultra Max Multi-Source.....	32
SuperStor Ultra Commercial.....	34
SuperStor Contender Titanium.....	36
SuperStor Contender.....	38

Storage Tanks

SuperStor Ultra Storage.....	40
SuperStor Ultra Glass Lined Storage.....	42

ELEVATE DEMAND RESPONSE

Residential Electric Water Heaters



Benefits

- **DYNAMIC CAPACITY** – Design optimized to provide up to the same amount of hot water as a 100 gallon conventional electric water heater, from a 55 gallon tank.
- **MAXIMUM DURABILITY** – Constructed of high-quality stainless steel, using low-watt density titanium elements, backed by an industry-leading Lifetime Limited Warranty.*
- **SIMPLE INSTALLATION** – Lightweight and easier to handle than glass-lined water heaters, making new or retrofit installations a breeze by seamlessly fitting into the footprint of an 80 gallon unit.
- **OUT OF THE BOX COMPLIANCE** with jurisdictions requiring installation of a thermostatic mixing valve.

Features

- **MAXIMUM SAFETY WITH INTEGRATED SCALD PROTECTION** – Built-in ASSE 1017/ ASSE 1070 certified mixing valve ensures heated water is delivered at a consistent, safe temperature.
- **I-MEMORY** self-learning habit algorithm which will ensure you have hot water when you need it and save energy when you don't.
- **ECOPORT CERTIFIED** Demand Response ready.
- **DAILY SCHEDULING** set up daily scheduling to ensure hot water is available when needed most.
- **ELECTRONIC TEMPERATURE CONTROL** for precise temperature control and improved performance combined with an energy cut-off to prevent overheating.
- **USER-FRIENDLY LCD DISPLAY** screen that allows for easy view of current operational status, parameter changing, and diagnostics.
- **TEMPERATURE AND PRESSURE RELIEF VALVE** – Factory installed.
- **DRYFIRE PROTECTION** protects the water heater from damaging the elements if the tank is not properly filled.
- **DURABLE BRASS DRAIN VALVE** – Factory installed for fast and easy draining.

Performance

- **UEF RATING OF 0.94**
- **77 GALLON FIRST HOUR RATING (FHR)**
- **UP TO 115 GAL OF 105 °F AT THE FIXTURE WHEN TANK IS SET TO 170 °F**
- **240 VOLTS, 4500-WATT INPUT**
- **MEETS ALL EFFICIENCY REQUIREMENTS OF THE DOE**
- **NAECA III COMPLIANT**

Quality

- **316L STAINLESS STEEL TANK**
- **ALUMINUM ANODE ROD FOR ADDITIONAL PROTECTION**
- **LIMITED LIFETIME WARRANTY* / 8 YEAR COMPONENTS***



Globally Recognized. Industry Respected.

*With online registration. See product warranty for details.

SPECIFICATIONS AND APPLICATION DATA

MODEL	NOMINAL CAPACITY (GAL)	DOE RATED CAPACITY (GAL)	WATTAGE	VOLTAGE	FIRST HOUR RATING (GAL)	UEF	RECOVERY @ 90 °F RISE (GAL.)	FROM MIXING VALVE		FROM THERMOSTAT		SHIPPING WEIGHT
								MIN DELIVERY TEMP	MAX DELIVERY TEMP	MIN DELIVERY TEMP	MAX DELIVERY TEMP	
ELV055C2X045NDR	55	55	4500	240	77	0.94	20	90 °F 32 °C	130 °F 54 °C	90 °F 32 °C	170 °F 77 °C	154 lbs. 70 kg

SPECIFICATIONS AND DIMENSIONS

MODELS	GAL.	DRAIN HEIGHT A	T&P HEIGHT B	TOP OF HEATER C	OVERALL HEIGHT D	DIAMETER E	WATER CONNECTION DISTANCE F	HOT/COLD PORTS
ELV055C2X045NDR	55	6 ½"	41 ½"	51"	58"	23 ¼"	8"	¾" NPT

STORAGE TEMP WITH EQUIVALENT CAPACITY

TANK SET TEMP °F	125 FACTORY SETTING	140	150	170
Equivalent Capacity (GAL.)	55	65	80	100
Consecutive Showers (8 mins @ 3GPM)	3	3.5	4	5

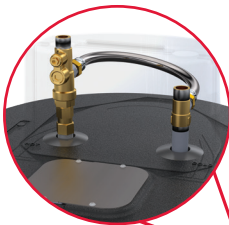

MIXING VALVE ASSEMBLY DETAIL

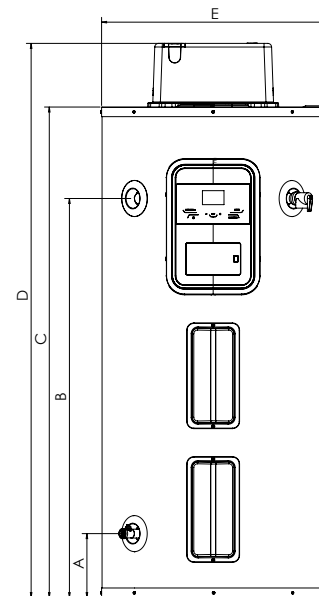
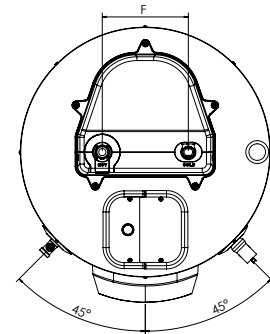
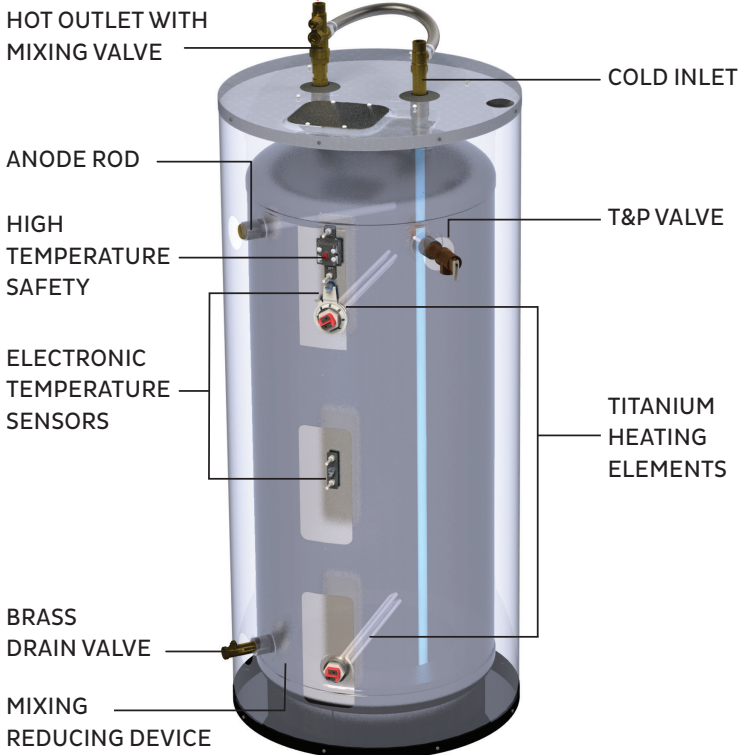

EVERLAST® ELEVATE

Residential Electric Water Heaters



Benefits

- **DYNAMIC CAPACITY** – Design optimized to provide up to the same amount of hot water as a 100 gallon conventional electric water heater, from a 55 gallon tank.
- **MAXIMUM DURABILITY** – Constructed of high-quality stainless steel, using low-watt density titanium elements, backed by an industry leading Lifetime Limited Warranty.*
- **SIMPLE INSTALLATION** – Lightweight and easier to handle than glass-lined water heaters, making new or retrofit installations a breeze by seamlessly fitting into the footprint of an 80 gallon unit.
- **OUT OF THE BOX COMPLIANCE** with jurisdictions requiring installation of a thermostatic mixing valve.

Features

- **MAXIMUM SAFETY WITH INTEGRATED SCALD PROTECTION** – Built-in ASSE 1017/ ASSE 1070 certified mixing valve ensures heated water is delivered at a consistent, safe temperature.
- **FULLY AUTOMATIC SURFACE MOUNTED THERMOSTATS** for controlling the temperature, combined with a manual energy cut-off to prevent overheating.
- **TEMPERATURE AND PRESSURE RELIEF VALVE** – Factory installed.
- **FULL PORT BRASS DRAIN VALVE** – Factory installed for fast and easy draining.

Performance

- UEF RATING OF 0.94
- UP TO 115 GAL OF 105 °F AT THE FIXTURE WHEN TANK IS SET TO 170 °F
- 240 VOLTS, 5500-WATT INPUT
- MEETS ALL EFFICIENCY REQUIREMENTS OF THE DOE
- NAECA III COMPLIANT

Quality

- 316L STAINLESS STEEL TANK
- ALUMINUM ANODE ROD FOR ADDITIONAL PROTECTION
- LIMITED LIFETIME WARRANTY* / 6 YEAR COMPONENTS*



Globally Recognized. Industry Respected.

*With online registration. See product warranty for details.

SPECIFICATIONS AND APPLICATION DATA

MODELS	SAFETY LISTING	# OF ELEMENTS & THERMOSTATS	WATTAGE	VOLTAGE	FULL LOAD CURRENT IN AMPS (SINGLE PHASE)	AHRI CERTIFIED RATINGS			RECOVERY @ 90 °F RISE (GAL.)	WATER TEMPERATURE RATINGS					SHIPPING WEIGHT
						FIRST HOUR BIN	FIRST HOUR RATING (GAL.)	UEF		FROM MIXING VALVE		FROM THERMOSTAT		HIGH TEMP LIMIT	
										MIN DELIVERY TEMP	MAX DELIVERY TEMP	MIN DELIVERY TEMP	MAX DELIVERY TEMP		
ELV055C2X055N	UL 174	2	5500	240	23	High	77	0.94	24	90 °F 32 °C	130 °F 54.4 °C	125 °F 51.7 °C	170 °F 76.7 °C	190 °F 87.8 °C	150 lbs. 68 kg

SPECIFICATIONS AND DIMENSIONS

MODELS	GAL.	A	B	C	D	E	F	HOT/COLD PORTS
ELV055C2X055N	55	6 ¼"	41 ½"	51"	58"	23 ¾"	8"	¾" NPT

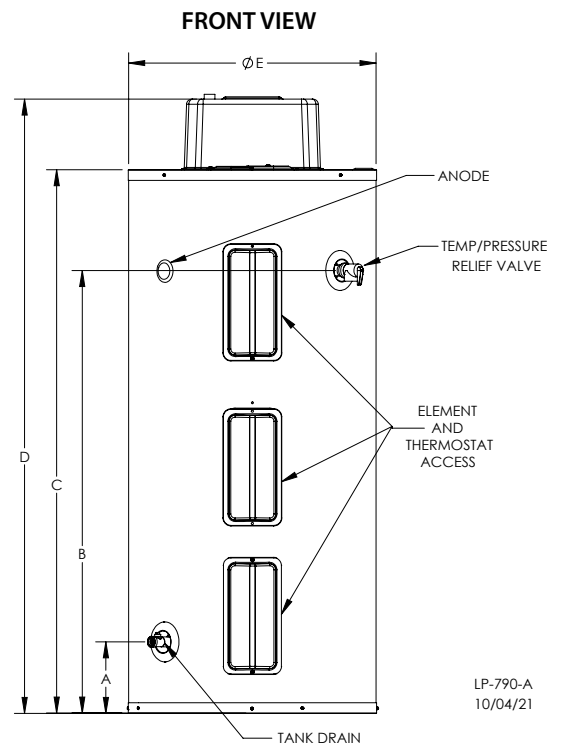
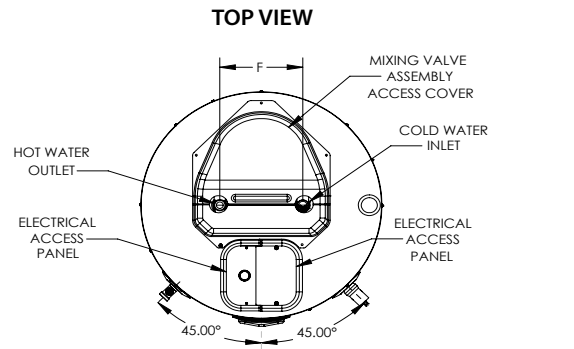
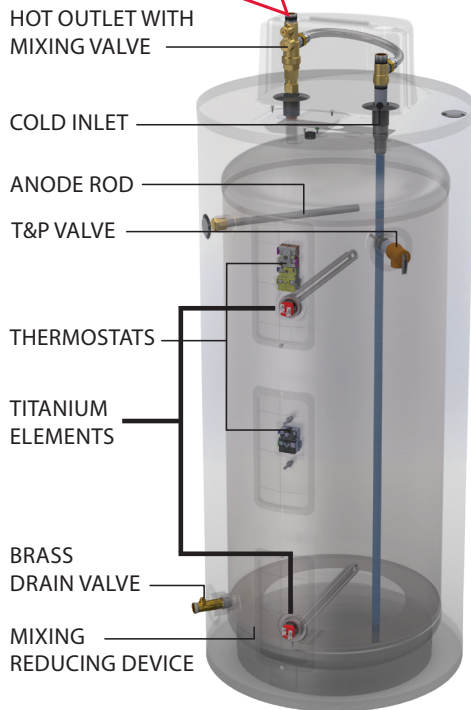

LP-790-A
10/04/21

EVERLAST® DEMAND RESPONSE

Residential Electric Water Heaters



Features

- **I-MEMORY** self-learning habit algorithm which will ensure you have hot water when you need it and save energy when you don't.
- **STAINLESS STEEL** tank constructed of high-quality, lightweight stainless steel making it easier to handle than glass-lined water heaters.
- **DAILY SCHEDULING** set up daily scheduling to ensure that hot water is available when needed most.
- **ECOPOINT CERTIFIED** Demand Response ready.
- **TITANIUM HEATING ELEMENTS** two low-wattage density elements to ensure more efficient operation and longer element life.
- **ELECTRONIC TEMPERATURE CONTROL** for precise temperature control and improved performance combined with an energy cut-off to prevent overheating.
- **USER-FRIENDLY LCD DISPLAY** screen that allows for easy view of current operational status, parameter changing, and diagnostics.
- **TEMPERATURE AND PRESSURE RELIEF VALVE** – Factory installed.
- **DRYFIRE PROTECTION** protects the water heater from damaging the elements if the tank is not properly filled.
- **DURABLE BRASS DRAIN VALVE** – Factory installed for fast and easy draining.

Performance

- UP TO .94 UEF RATING
- UP TO 65 GALLON FIRST HOUR RATING (FHR)
- 240 VOLTS, 4500-WATT INPUT
- MEETS ALL EFFICIENCY REQUIREMENTS OF THE DOE
- NAECA III COMPLIANT

Quality

- 316L STAINLESS STEEL TANK
- LIMITED LIFETIME WARRANTY*



Globally Recognized. Industry Respected.

*With online registration. See product warranty for details.

SPECIFICATIONS AND APPLICATION DATA

MODELS	NOMINAL CAPACITY (GAL)	DOE RATED CAPACITY (GAL)	WATTAGE	VOLTAGE	FIRST HOUR RATING (GAL.)	UEF	RECOVERY @ 90 °F RISE (GAL.)	MIN DELIVERY TEMP	MAX DELIVERY TEMP	SHIPPING WEIGHT
EVR040C2X045NDR	40	39	4500	240	57	0.94	20	104 °F 40 °C	150 °F 66 °C	115 lbs. 52 kg
EVR052C2X045NDR	52	48	4500	240	65	0.93	20	104 °F 40 °C	150 °F 66 °C	131 lbs. 59 kg

SPECIFICATIONS AND DIMENSIONS

MODELS	GAL.	DRAIN HEIGHT	T&P HEIGHT	TOP OF HEATER	DIAMETER	WATER CONNECTION DISTANCE	HOT/COLD PORTS
		A	B	C	D	E	
EVR040C2X045NDR	40	5 3/4"	46"	54 1/4"	19 1/2"	8"	3/4" NPT
EVR052C2X045NDR	52	5 3/4"	58 1/4"	66 3/4"	19 1/2"	8"	3/4" NPT

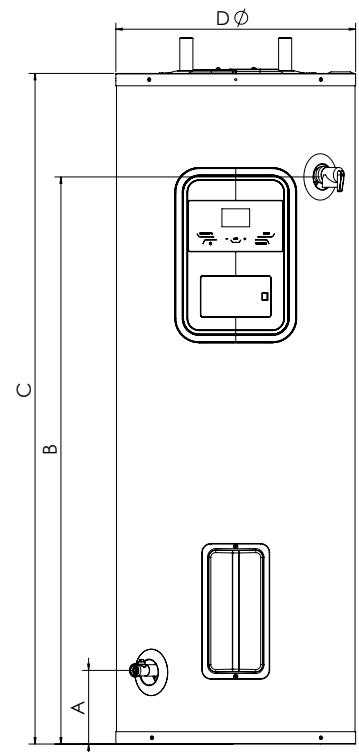
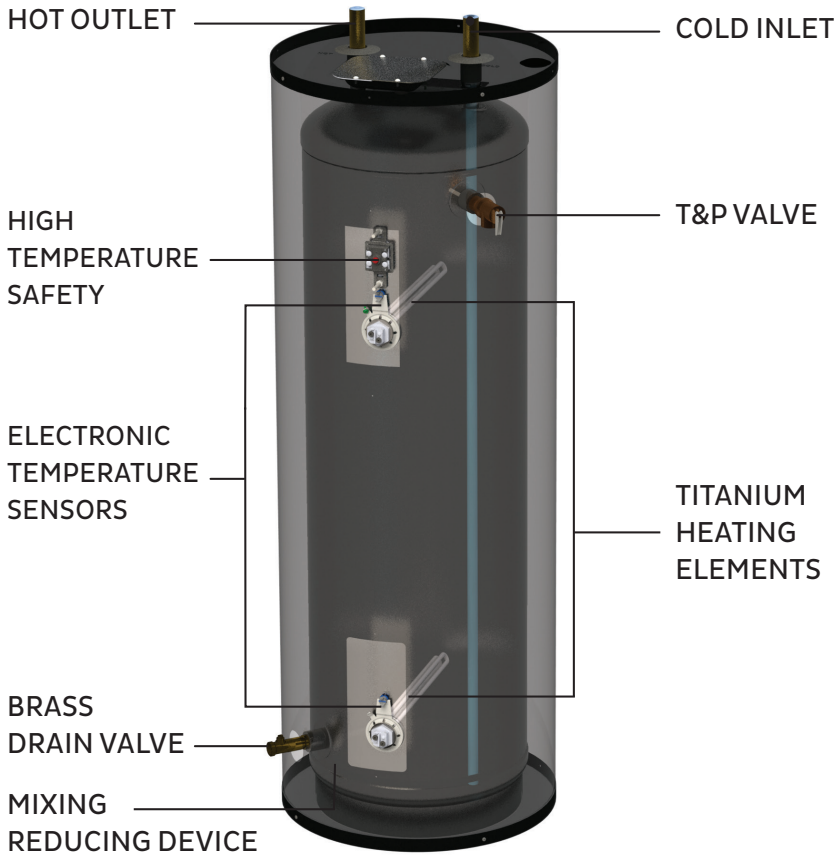
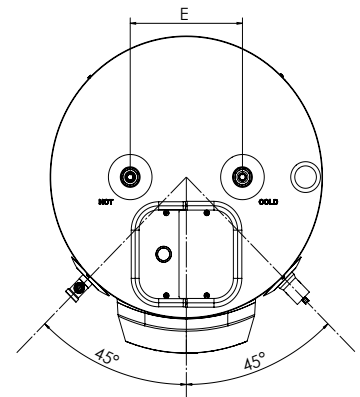

EVERLAST® RESIDENTIAL

Residential Electric Water Heaters



Features

- **STAINLESS STEEL** tank constructed of high-quality, lightweight stainless steel making it easier to handle than glass-lined water heaters.
- **TITANIUM HEATING ELEMENTS** two low-wattage density elements to ensure more efficient operation and longer element life.
- **MIXING REDUCING DEVICE** strategically designed to keep the incoming cold water in the lowest part of the tank to reduce mixing in the tank and increase performance and efficiency.
- **INLET DIPTUBE** injects cold water into the bottom of the tank to ensure only the hottest water is drawn from the top of the tank.
- **FULLY AUTOMATIC SURFACE MOUNTED THERMOSTATS** for controlling the temperature, combined with a automatic energy cut-off to prevent overheating.
- **TEMPERATURE AND PRESSURE RELIEF VALVE** – Factory installed.
- **DURABLE BRASS DRAIN VALVE** – Factory installed for fast and easy draining.

Performance

- **UP TO .94 UEF RATING**
- **UP TO 62 GALLON FIRST HOUR RATING (FHR)**
- **240 VOLTS, 4500 OR 5500-WATT INPUT**
- **ENVIRONMENTALLY SAFE NON-CFC FOAM** 2+ inches of super foam insulation for low standby loss
- **MEETS ALL EFFICIENCY REQUIREMENTS OF THE DOE**
- **AHRI CERTIFIED AND LISTED**
- **NAECA III COMPLIANT**

Quality

- **316L STAINLESS STEEL TANK**
- **NO ANODE ROD NEEDED**
- **LIMITED LIFETIME TANK WARRANTY* / 6 YEAR COMPONENTS***



Globally Recognized. Industry Respected.

*With online registration. See product warranty for details.

SPECIFICATIONS AND APPLICATION DATA

MODELS	NOMINAL CAPACITY (GAL)	DOE RATED CAPACITY (GAL)	WATTAGE	VOLTAGE	FIRST HOUR RATING (GAL)	UEF	RECOVERY @ 90°F RISE (GAL)	MIN DELIVERY TEMP	MAX DELIVERY TEMP	HIGH TEMP LIMIT	INLET/OUTLET SIZE
EVR040C2X045N	40	39	4,500	240	56	0.94	20	110°F (43.3°C)	150°F (65.5°C)	170°F (76.6°C)	3/4" NPT
EVR040C2X055N	40	39	5,500	240	56	0.94	25	110°F (43.3°C)	150°F (65.5°C)	170°F (76.6°C)	3/4" NPT
EVR052C2X045N	52	48	4,500	240	62	0.93	20	110°F (43.3°C)	150°F (65.5°C)	170°F (76.6°C)	3/4" NPT
EVR052C2X055N	52	48	5,500	240	62	0.93	25	110°F (43.3°C)	150°F (65.5°C)	170°F (76.6°C)	3/4" NPT

SPECIFICATIONS AND DIMENSIONS

MODELS	DRAIN HEIGHT	T & P HEIGHT	TOP OF HEATER	DIAMETER	WATER CONNECTIONS DISTANCE	SHIPPING WEIGHT
	A	B	C	D	E	
EVR040C2X045N	5 3/4"	46"	54 1/4"	19 1/2"	8"	104
EVR040C2X055N	5 3/4"	46"	54 1/4"	19 1/2"	8"	104
EVR052C2X045N	5 3/4"	58 1/4"	66 3/4"	19 1/2"	8"	118
EVR052C2X055N	5 3/4"	58 1/4"	66 3/4"	19 1/2"	8"	118

TOP VIEW

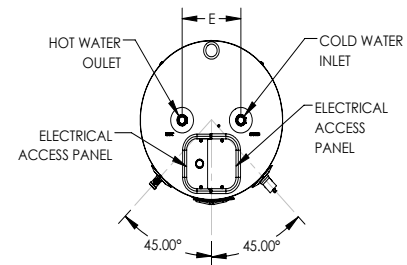

FRONT VIEW

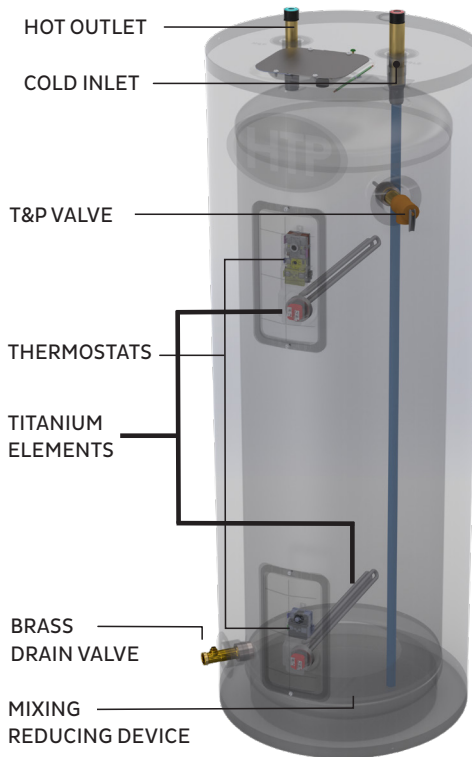
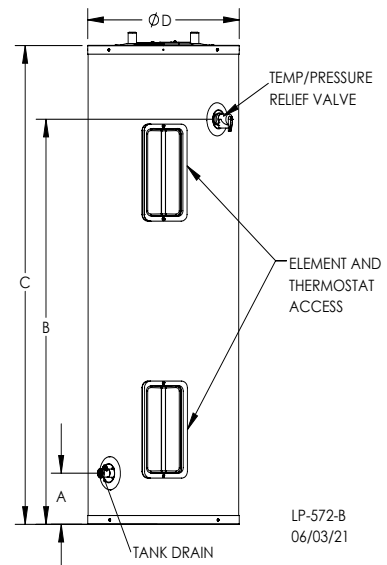

EVERLAST® GRID ENABLED

Residential Electric Water Heaters



Features

- **COMPLIES WITH LAW 114-11** – The Energy Efficiency Improvement Act of 2015.
- **MECHANICAL LOWER ELEMENT LOCK-OUT** no electronics or software required, unit ships with lower heating element locked. Key included for easy activation upon installation.
- **STAINLESS STEEL** tank constructed of high-quality, lightweight stainless steel making it easier to handle than glass-lined water heaters.
- **TITANIUM HEATING ELEMENT** two low-wattage density elements to ensure more efficient operation and longer element life.
- **MIXING REDUCING DEVICE** strategically designed to keep the incoming cold water in the lowest part of the tank to reduce mixing in the tank and increase performance and efficiency.
- **COMBINATION INLET AND DRAIN VALVE** – allows for easy installation.
- **INLET DIPTUBE** injects cold water into the bottom of the tank to ensure only the hottest water is drawn from the top of the tank.
- **FULLY AUTOMATIC SURFACE MOUNTED THERMOSTATS** for controlling the temperature, combined with a automatic energy cut-off to prevent overheating
- **TEMPERATURE AND PRESSURE RELIEF VALVE** – Factory installed.
- **DURABLE BRASS DRAIN VALVE** – Factory installed for fast and easy draining.

Performance

- UP TO .93 UEF RATING
- UP TO 101 GALLON FIRST HOUR RATING (FHR)
- 240 VOLTS, 4,500 OR 5,500- WATT INPUT
- ENVIRONMENTALLY SAFE NON-CFC FOAM 2+ INCHES OF SUPER FOAM INSULATION FOR LOW STANDBY LOSS
- MEETS ALL EFFICIENCY REQUIREMENTS OF THE DOE
- AHRI CERTIFIED AND LISTED
- NAECA III COMPLIANT

Quality

- 316L STAINLESS STEEL TANK
- NO ANODE ROD NEEDED
- LIMITED LIFETIME TANK WARRANTY* / 6 YEAR COMPONENTS*



Globally Recognized. Industry Respected.

*With online registration. See product warranty for details.

SPECIFICATIONS AND APPLICATION DATA

MODELS	NOMINAL CAPACITY (GAL)	DOE RATED CAPACITY (GAL)	WATTAGE	VOLTAGE	FIRST HOUR RATING (GAL)	UEF	RECOVERY @ 90 °F RISE (GAL.)	MIN DELIVERY TEMP	MAX DELIVERY TEMP	INLET/ OUTLET SIZE
EVG080C2X045H	80	78	4500	240	86	0.93	20	110 °F (43.3 °C)	170 °F (76.7 °C)	¾" NPT
EVG080C2X055H	80	78	5500	240	86	0.93	25	110 °F (43.3 °C)	170 °F (76.7 °C)	¾" NPT
EVG100C2X045H	100	96	4500	240	86	0.93	20	110 °F (43.3 °C)	170 °F (76.7 °C)	¾" NPT
EVG100C2X055H	100	96	5500	240	86	0.93	25	110 °F (43.3 °C)	170 °F (76.7 °C)	¾" NPT
EVG115C2X045H	115	111	4500	240	101	0.90	20	110 °F (43.3 °C)	170 °F (76.7 °C)	¾" NPT

SPECIFICATIONS AND DIMENSIONS

MODELS	DRAIN HEIGHT	T&P HEIGHT	TOP OF HEATER	DIAMETER	WATER CONNECTIONS DISTANCE	SHIPPING WEIGHT
	A	B	C	D	E	
EVG080*	6 ½"	69"	23 ¾"	60"	8"	151 lbs
EVG100*	7 ½"	61"	27"	52"	8"	206 lbs
EVG115*	7 ½"	69"	27"	60"	8"	224 lbs

TOP VIEW

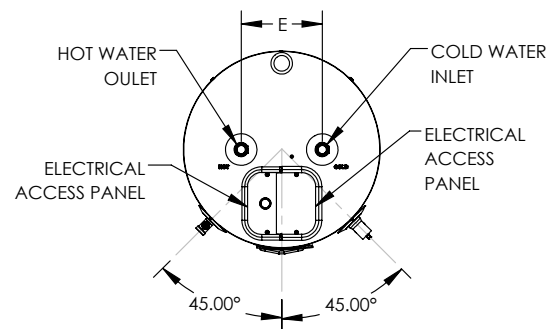

FRONT VIEW

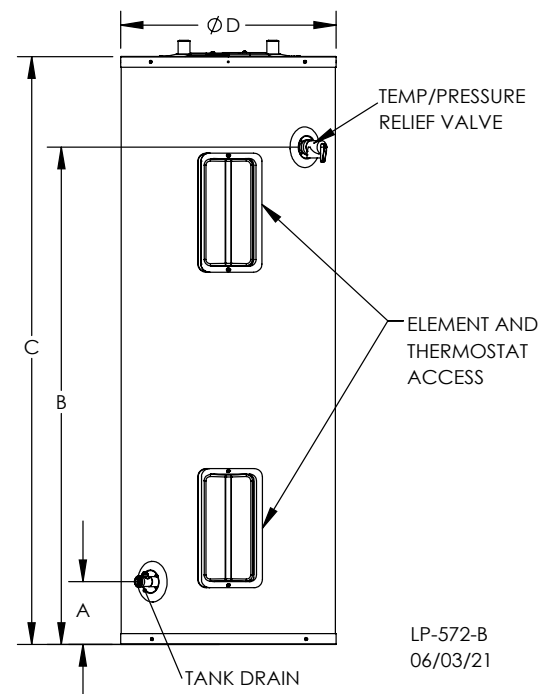

LP-572-B
06/03/21

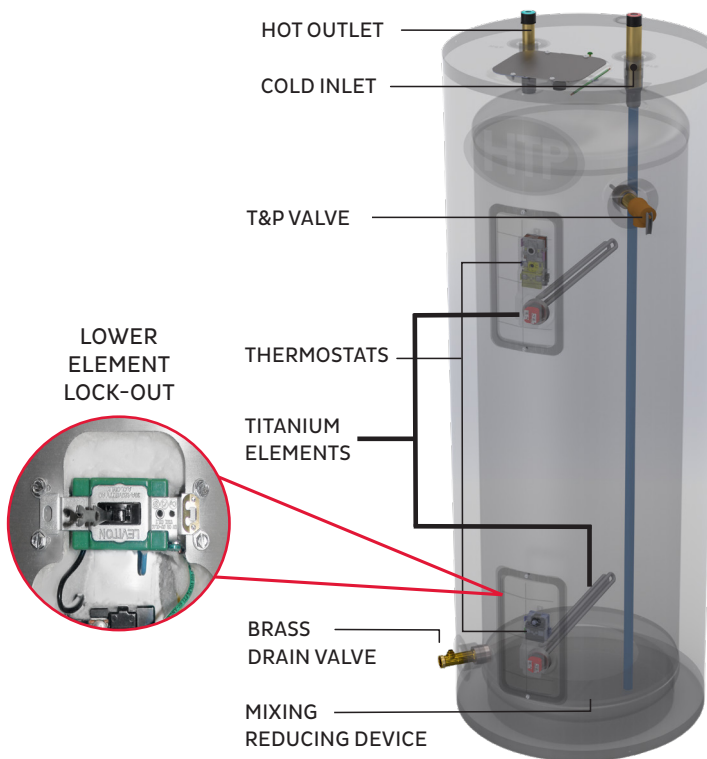

EVERLAST® MINI TANK

Residential Electric Water Heaters



Features

- **TITANIUM GLASS LINED TANK** durable titanium infused glass lining ensures years of use without worry.
- **COPPER HEATING ELEMENT** provides superior performance and superior corrosion resistance for longer element life.
- **COMPACT DESIGN** can be floor standing or wall mount to fit any installation (wall mounting bracket included)
- **VERSATILE INSTALLATION** can be installed right at the point of use for single or multi-faucet use, or can be installed in-line with a standard water heater as a booster at the point of use.
- **INSTANT HOT WATER** installation at the point of use eliminates the need for a recirc-line and stores hot water right where you need it most.
- **TOP INLET AND OUTLET** allows for easy under-sink installation.
- **SIMPLE WIRING** 2.5 and 4 gallon models have a simple 120v plug-in connection, 8 gallon is hard wired.
- **EASY TEMPERATURE CONTROL** using front mounted control knob with LED indication light.
- **FULLY AUTOMATIC SURFACE MOUNTED THERMOSTAT** for controlling the temperature, combined with a automatic energy cut-off to prevent overheating.
- **TEMPERATURE AND PRESSURE RELIEF VALVE** – Included, factory installed on the 2.5 and 4 gallon models.



Performance

- 120 VOLTS, 1,440 OR 2,000 WATT INPUT
- ENVIRONMENTALLY SAFE NON-CFC FOAM INSULATION FOR LOW STANDBY LOSS
- NAECA III COMPLIANT

Quality

- TITANIUM INFUSED GLASS LINED TANK
- COPPER HEATING ELEMENTS
- LIMITED 6 YEAR TANK WARRANTY / 2 YEAR COMPONENTS

SPECIFICATIONS AND APPLICATION DATA

MODELS	NOMINAL CAPACITY (GAL)	WATTAGE	VOLTAGE	RECOVERY @ 90 °F RISE (GAL)	MIN DELIVERY TEMP	MAX DELIVERY TEMP	INLET/ OUTLET SIZE
EVR02.5A014C	2.5	1,440	120	7	65 °F (18.5°C)	161 °F (71.5°C)	½" NPT
EVR04.0A014C	4.0	1,440	120	7	65 °F (18.5°C)	161 °F (71.5°C)	½" NPT
EVR08.0A020C	8.0	2,000	120	9	65 °F (18.5°C)	161 °F (71.5°C)	¾" NPT

SPECIFICATIONS AND DIMENSIONS

MODELS	HEIGHT/ WIDTH	PRODUCT DEPTH	T&P TO REAR DISTANCE	INLET/OUTLET TO REAR DISTANCE	INLET/ OUTLET HEIGHT	WATER CONNECTIONS DISTANCE	WALL MOUNT BRACKET FROM TOP	WALL MOUNT BRACKET HOLE DISTANCE	SHIPPING WEIGHT
	A	B	C	D	E	F	G	H	
EVR02.5A014C	14 ¼"	10 ¾"	6"	3 ½"	1"	3 ¾"	5 ¼"	2 ½"	20lbs
EVR04.0A014C	14 ¼"	12 ¾"	7 ½"	3 ½"	1"	3 ¾"	5 ¼"	2 ½"	22lbs
EVR08.0A020C	17 ½"	15 ¼"	8 ½"	4 ½"	1 ¼"	3 ¾"	6 ½"	2 ½"	32lbs

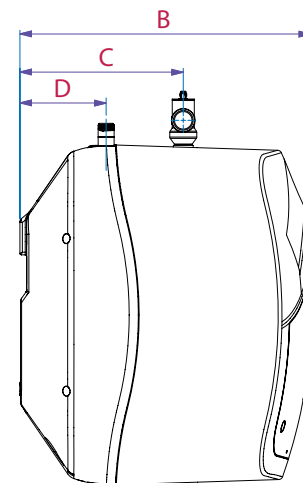
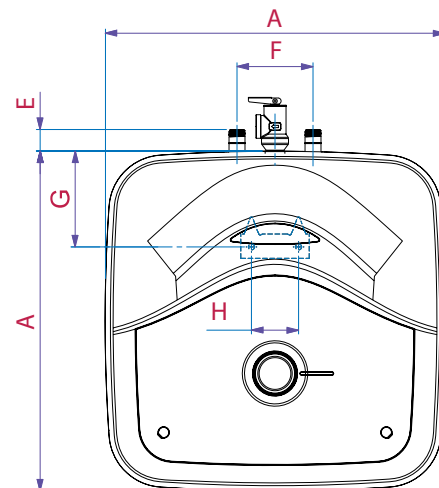
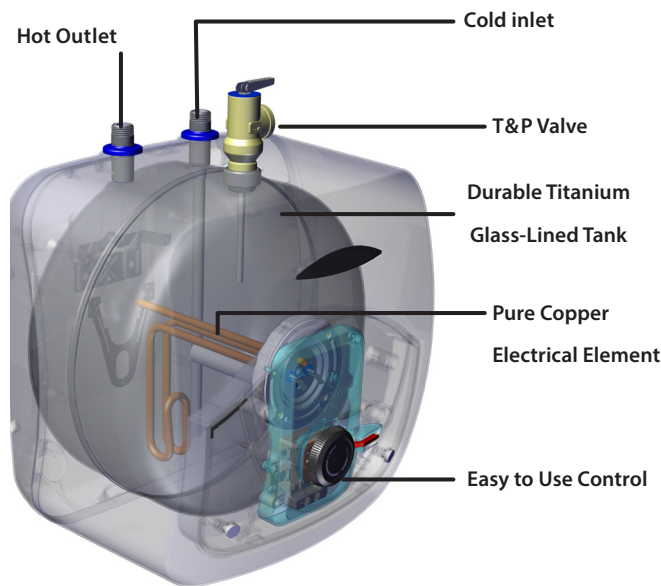

EVERLAST® LIGHT DUTY

Commercial Electric Water Heaters



Features

- **VERSATILE CONFIGURATIONS** – Can operate on single-phase or three-phase power, and elements can be wired for simultaneous or non-simultaneous operation.
- **TERMINAL BLOCK** – allows for easy phase or operational conversions in the field.
- **LIGHTWEIGHT CONSTRUCTION** crafted from high-quality 316L stainless steel, the EVERLAST line is easier to handle than glass-lined competitors.
- **TITANIUM HEATING ELEMENTS** two low watt-density elements to ensure longer element life.
- **FULLY AUTOMATIC SURFACE MOUNTED HIGH TEMPERATURE THERMOSTATS** adjustable up to 181°F. Simple and reliable.
- **TEMPERATURE AND PRESSURE RELIEF VALVE** – Factory installed.
- **DURABLE BRASS DRAIN VALVE** – Factory installed for fast and easy draining.

Performance

- 277 VOLTS
- 12,200-WATT INPUT
- MEETS OR EXCEEDS THE STANDBY LOSS REQUIREMENTS OF THE U.S. DEPARTMENT OF ENERGY
- AHRI CERTIFIED AND LISTED
- 2+ INCHES OF CALIFORNIA COMPLIANT LOW-GWP FOAM INSULATION
- NSF CERTIFIED

Warranty

- LIMITED 10 YEAR TANK WARRANTY / 1 YEAR COMPONENTS



Globally Recognized. Industry Respected.

SPECIFICATIONS AND APPLICATION DATA

MODELS	NOMINAL CAPACITY (GAL)	WATTAGE	VOLTAGE	# OF THERMOSTATS	# OF ELEMENTS	MIN DELIVERY TEMP	MAX DELIVERY TEMP	HIGH TEMP. LIMIT	INLET/ OUTLET SIZE
EVC080D2W122	80	12,200	277	2	2	120 °F (48.8 °C)	181 °F (82.8 °C)	200 °F (93.3 °C)	¾" NPT
EVC119D2W122	119	12,200	277	2	2	120 °F (48.8 °C)	181 °F (82.8 °C)	200 °F (93.3 °C)	¾" NPT

SPECIFICATIONS AND DIMENSIONS

MODELS	INLET/DRAIN HEIGHT	T&P HEIGHT	TOP OF HEATER	DIAMETER	WATER CONNECTIONS DISTANCE	SHIPPING WEIGHT
	A	B	C	D	E	
EVC080D2W122	6 ½"	60"	69"	23 ¾"	8"	185 lbs
EVC119D2W122	7 ¼"	60"	69"	27"	8"	250 lbs

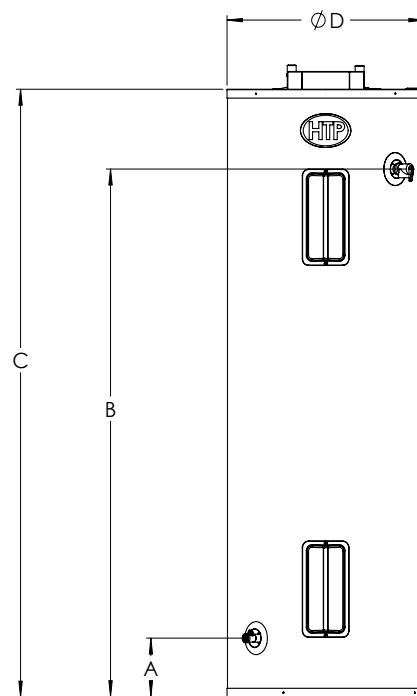
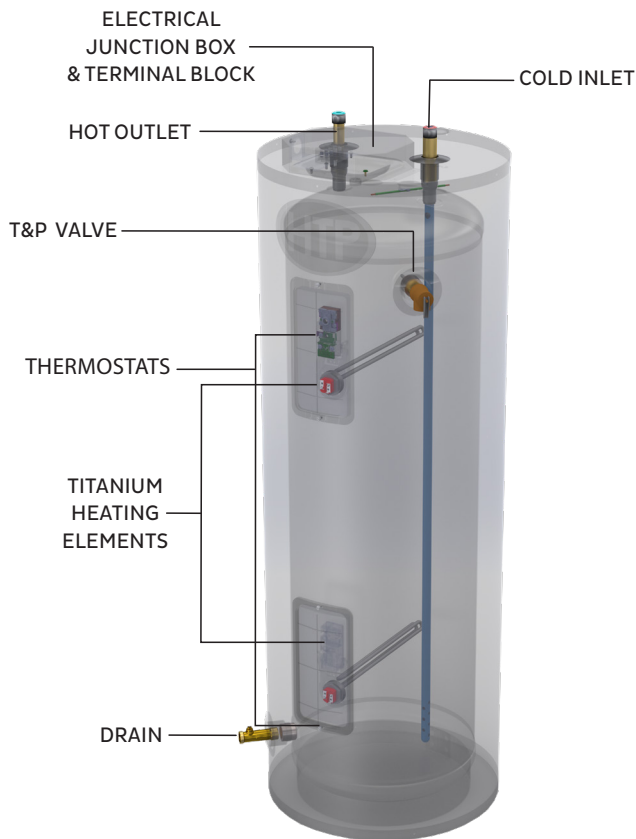
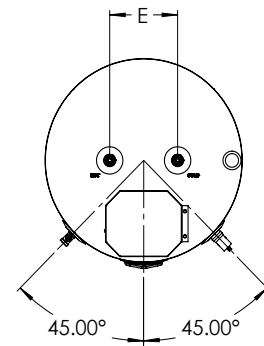

EVERLAST® MEDIUM DUTY

Commercial Electric Water Heaters



Features

- **DURABLE STEEL ENCLOSURE** – hinged cover provides easy access to internal fuses and wiring.
- **TERMINAL BLOCK** – allows for easy phase or operational conversions. Can be changed from single phase to 3-phase power and/or simultaneous operation to non-simultaneous.
- **INTERNALLY FUSED** – easily serviceable and added protection.
- **VERSATILE CONFIGURATIONS** – multiple heating element kits for fast and easy input configuration conversions.
- **STAINLESS STEEL** tank constructed of high-quality, lightweight stainless steel making it easier to handle than glass-lined water heaters.
- **TITANIUM HEATING ELEMENTS** 3 low-wattage density elements to ensure more efficient operation and longer element life.
- **FULLY AUTOMATIC SURFACE MOUNTED HIGH TEMPERATURE THERMOSTATS** adjustable up to 181°F, combined with a automatic energy cut-off to prevent overheating.
- **TEMPERATURE AND PRESSURE RELIEF VALVE** – Factory installed.
- **DURABLE BRASS DRAIN VALVE** – Factory installed for fast and easy draining.

Performance

- 208, 240, 277, AND 480 VOLTS
- 13,500 TO 18,000-WATT INPUT
- ENVIRONMENTALLY SAFE NON-CFC FOAM 2+ INCHES OF SUPER FOAM INSULATION FOR LOW STANDBY LOSS
- NSF 5 CERTIFIED
- AHRI CERTIFIED AND LISTED
- NAECA III COMPLIANT

Quality

- 316L STAINLESS STEEL TANK
- NO ANODE ROD NEEDED
- LIMITED 10 YEAR TANK WARRANTY* / 1 YEAR COMPONENTS*



Globally Recognized. Industry Respected.

*With online registration. See product warranty for details.

SPECIFICATIONS AND APPLICATION DATA

MODELS	NOMINAL CAPACITY (GAL)	WATTAGE	VOLTAGE	# OF THERMOSTATS	# OF FUSES	# OF FUSE HOLDERS	MIN DELIVERY TEMP	MAX DELIVERY TEMP	HIGH TEMP. LIMIT	INLET/OUTLET SIZE
EVC080B3W135	80	13,500	208	3	6	2	120 °F (48.8 °C)	181 °F (82.8 °C)	200 °F (93.3 °C)	¾" NPT
EVC080C3W135	80	13,500	240	3	6	2	120 °F (48.8 °C)	181 °F (82.8 °C)	200 °F (93.3 °C)	¾" NPT
EVC080C3W165	80	16,500	240	3	6	2	120 °F (48.8 °C)	181 °F (82.8 °C)	200 °F (93.3 °C)	¾" NPT
EVC080D3W180	80	18,000	277	3	6	2	120 °F (48.8 °C)	181 °F (82.8 °C)	200 °F (93.3 °C)	¾" NPT
EVC080E3W180	80	18,000	480	3	6	2	120 °F (48.8 °C)	181 °F (82.8 °C)	200 °F (93.3 °C)	¾" NPT
EVC100C3W135	100	13,500	240	3	6	2	120 °F (48.8 °C)	181 °F (82.8 °C)	200 °F (93.3 °C)	¾" NPT
EVC100C3W165	100	16,500	240	3	6	2	120 °F (48.8 °C)	181 °F (82.8 °C)	200 °F (93.3 °C)	¾" NPT
EVC100D3W180	100	18,000	277	3	6	2	120 °F (48.8 °C)	181 °F (82.8 °C)	200 °F (93.3 °C)	¾" NPT
EVC100E3W180	100	18,000	480	3	6	2	120 °F (48.8 °C)	181 °F (82.8 °C)	200 °F (93.3 °C)	¾" NPT
EVC115C3W135	115	13,500	240	3	6	2	120 °F (48.8 °C)	181 °F (82.8 °C)	200 °F (93.3 °C)	¾" NPT
EVC115C3W165	115	16,500	240	3	6	2	120 °F (48.8 °C)	181 °F (82.8 °C)	200 °F (93.3 °C)	¾" NPT
EVC115D3W180	115	18,000	277	3	6	2	120 °F (48.8 °C)	181 °F (82.8 °C)	200 °F (93.3 °C)	¾" NPT
EVC115E3W180	115	18,000	480	3	6	2	135 °F (57.2 °C)	181 °F (82.8 °C)	200 °F (93.3 °C)	¾" NPT

SPECIFICATIONS AND DIMENSIONS

MODELS	INLET/DRAIN HEIGHT	T&P HEIGHT	TOP OF HEATER	DIAMETER	WATER CONNECTIONS DISTANCE	PRODUCT DEPTH	SHIPPING WEIGHT
	A	B	C	D	E	F	
EVC080C3W135	6 ½"	60"	69"	23 ¾"	8"	26"	165 lbs
EVC100C3W135	7 ¾"	52"	61"	27"	8"	30"	220 lbs
EVC115C3W135	7 ¾"	60"	69"	27"	8"	30"	240 lbs

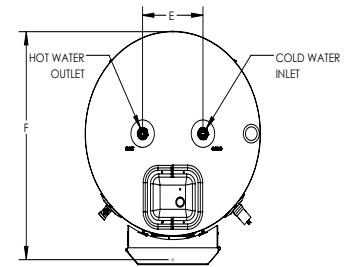

Optional Element Kits (Sold Separately)				
INPUT (WATTS)	208V	240V	277V	480V
12500	B3W125	NO	NO	NO
13500	B3W135	C3W135 (standard)		E3W135
14000	NO	NO	D3W140	NO
15000	NO	C3W150	D3W150	E3W150
16000	NO	NO	D3W160	NO
16500	NO	C3W165 (standard)	NO	E3W165
18000	NO	NO	D3WN180N (standard)	E3W180 (standard)

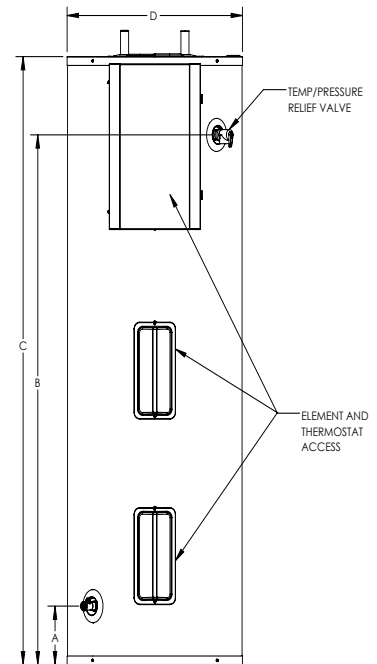

TOTAL INPUT (KW)	# OF ELEMENTS	SINGLE ELEMENT WATTAGE	Full Load Current in Amperes							
			208V PHASE		240V PHASE		277V PHASE		480V PHASE	
			1	3	1	3	1	3	1	3
12.5	3	4.2	60	35	-	-	-	-	-	-
13.5	3	4.5	65	38	57	33	-	-	29	17
14	3	4.7	-	-	-	-	51	30	-	-
15	3	5	-	-	63	36	55	32	32	18
16	3	5.3	-	-	-	-	58	34	-	-
16.5	3	5.5	-	-	69	40	-	-	35	20
18	3	6	-	-	-	-	65	38	38	22

PHOENIX LIGHT DUTY

Commercial Gas Water Heaters



Features

- **MODULATING BURNER** – Allows 3:1 turndown ratio to provide the correct amount of power when needed (25,000 to 76,000 BTU).
- **HIGH EFFICIENCY** – Up to 90 UEF and 206 gallon First Hour Rating.
- **MAXIMUM DURABILITY** – Tank constructed of high-quality stainless steel with a cupronickel heat exchanger that ensures years of maintenance-free operation.
- **LIGHTWEIGHT** – Stainless-steel tank for easier transportation and installation compared to traditional glass-lined water heaters.
- **FRONT COMBUSTION CHAMBER** – Allows for ease of access and servicing of the combustion assembly.
- **LCD SCREEN** – easy to read LCD (icon and text) display.
- **INTELLIGENT CONTROLS** – Monitor inlet and outlet water temperatures to automatically adjust modulation and ensure consistent performance.
- **VERSATILE VENTING** – Vents in 2" PVC, CPVC, or ULC S636 up to 150ft combined intake & exhaust.
- **FULLY AUTOMATIC TEMPERATURE CONTROLS** up to 160° F.
- **AUXILIARY PORT** for recirculation line or to hook up with an air handler.
- **TEMPERATURE AND PRESSURE RELIEF VALVE** – Included for ease of installation.
- **DURABLE BRASS DRAIN VALVE** – Factory installed for fast and easy draining.
- **GAS CONNECTION** – 1/2" female gas connection.
- **ADDED PROTECTION** – High quality aluminum anode rod to extend tank life.
- **NATURAL GAS AND LP MODELS AVAILABLE**
- **RESIDENTIAL WARRANTY** – 7-year Limited tank warranty (upgradable to 10-years) and 1 year parts.
- **COMMERCIAL WARRANTY** – 3-year Limited tank warranty (upgradeable to 5-year Limited warranty) and 1-year warranty on parts.



Globally Recognized. Industry Respected.

Plus

- MEETS ALL EFFICIENCY REQUIREMENTS OF THE DOE
- EXCEEDS ASHRAE 90.1B-1992 EFFICIENCY REQUIREMENTS
- ENERGY STAR RATED
- ENVIRONMENTALLY SAFE CFC FOAM 2+ INCHES OF SUPER FOAM INSULATION FOR LOW STANDBY LOSS
- AHRI CERTIFIED AND LISTED
- NSF 5 CERTIFIED
- ULTRA-LOW NOX RATED – PER SCAQMD RULE 1146.2
- ANSI Z21.10.3 CERTIFIED FOR SAFETY
- MEETS ALL REQUIREMENTS OF MASSACHUSETTS PLUMBING BOARD
- LEAD FREE – PER SAFE WATER DRINKING ACT SDWA SECTION 1417

SPECIFICATIONS AND APPLICATION DATA

MODELS	NOMINAL CAPACITY (GAL)	DOE RATED CAPACITY (GAL)	BTU INPUT NAT & LP GAS	FIRST HOUR RATING (GAL.)	UEF	RECOVERY EFFICIENCY %	GPH RECOVERY @ 100° RISE	AIR INTAKE/ EXHAUST VENT SIZE	COMBINED INTAKE/ EXHAUST VENT LENGTHS	INLET/ OUTLET SIZE
PH76-50	50	48	25,000-76,000	154	0.9	0.9	98	2"	150 FT	3/4" NPT
PH76-60	60	58	25,000 - 76,000	157	0.88	0.88	98	2"	150 FT	3/4" NPT
PH76-80	80	77	25,000 - 76,000	206	0.87	0.94	98	2"	150 FT	3/4" NPT

SPECIFICATIONS AND DIMENSIONS

MODELS	HEIGHT	GAS CONNECTION HEIGHT	INTAKE HEIGHT	EXHAUST HEIGHT	DIAMETER	PRODUCT DEPTH	WATER CONNECTIONS DISTANCE	AUX DEPTH	SHIPPING WEIGHT
	A	B	C	D	E	F	G	H	
PH76-50	44 1/4"	33"	33"	6 1/4"	23"	32 1/2"	8"	4"	155
PH76-60	52 3/4"	33"	33"	6 1/4"	23"	32 1/2"	8"	4"	170
PH76-80	49"	33"	33"	6 1/4"	23"	32 1/2"	8"	4"	195

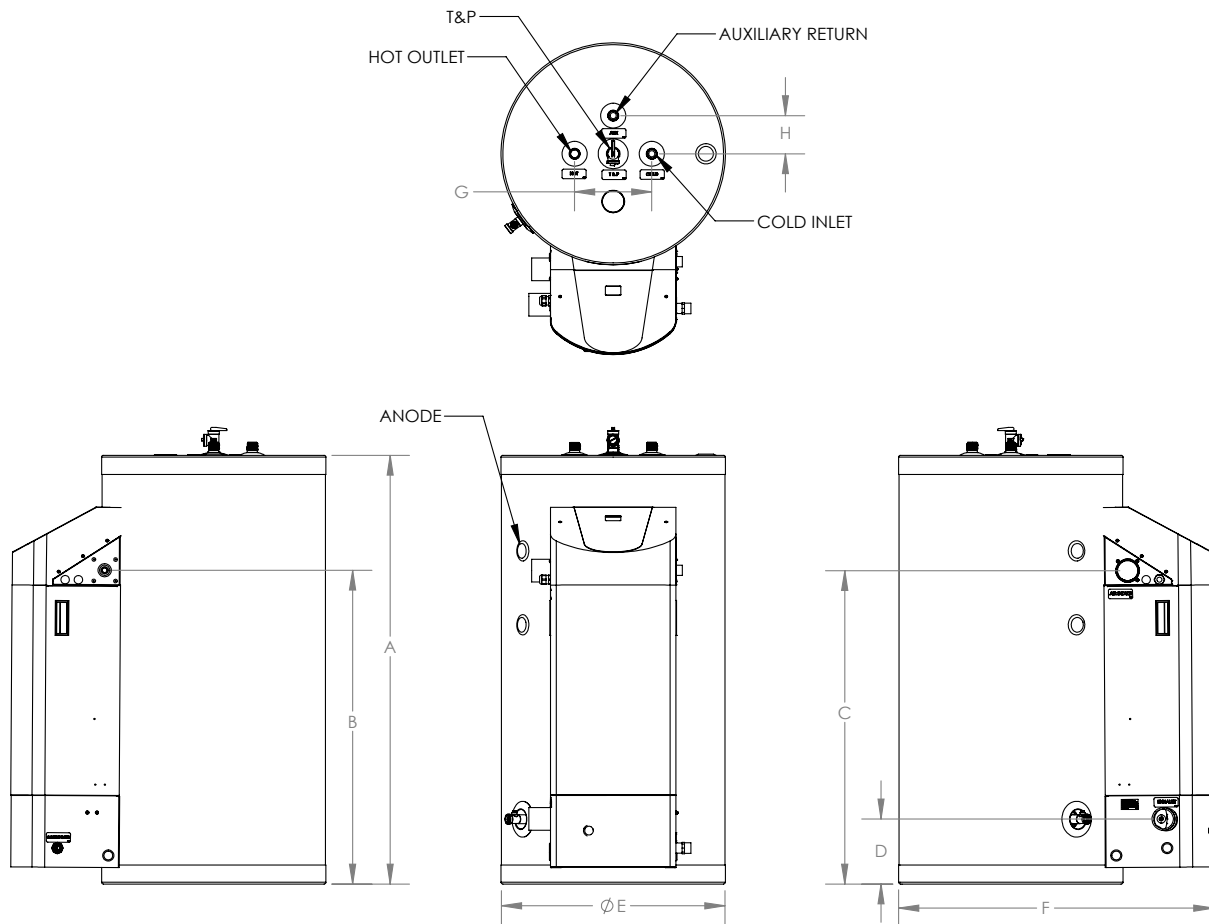

PHOENIX/PHOENIX MULTI-FIT

Commercial Gas Water Heaters



Features

- **MODULATING BURNER** – Allows 5:1 turndown ratio to provide the correct amount of power when needed.
- **HIGH EFFICIENCY** – Up to 96% thanks to the modulating-condensing combustion.
- **VARIETY OF POWER INPUTS** – Ranging from 100K to 199K BTU.
- **MAXIMUM DURABILITY** – Tank constructed of high-quality stainless steel with a cupronickel heat exchanger – combined with an anode rod – ensures years of maintenance-free operation.
- **LIGHTWEIGHT** – Stainless-steel tank for easier transportation and installation compared to traditional glass-lined water heaters.
- **MULTI-PORT CONFIGURATION** – Multi-fit models have top and side DHW connections to ensure installations – both new and retrofit – are easy.
- **FRONT COMBUSTION CHAMBER** – Allows for ease of access and servicing of the combustion assembly.
- **INTELLIGENT CONTROLS** – Monitor inlet and outlet water temperatures to automatically adjust modulation and ensure consistent performance.
- **VERSATILE VENTING** – Vents in PVC, CPVC, Stainless Steel, and ULC S636 up to 200ft combined intake & exhaust with 3".
- **NATURAL GAS MODELS WITH LP CONVERSION KITS** – Allow for fast conversions and reduced inventory requirements.
- **FULLY AUTOMATIC TEMPERATURE CONTROLS** up to 160° F.
- **TEMPERATURE AND PRESSURE RELIEF VALVE** – Factory installed.
- **FULL PORT BRASS DRAIN VALVE** – Factory installed for fast and easy draining.
- **GAS CONNECTION** – 3/4" female gas connection on all models.
- **ADDED PROTECTION** – High quality aluminum anode rod to extend tank life.
- **RESIDENTIAL WARRANTY** – 7-year Limited tank warranty and 1 year parts.
- **COMMERCIAL WARRANTY** – 3-year Limited tank warranty (upgradeable to 5-year Limited warranty) and 1-year warranty on parts.



Globally Recognized. Industry Respected.

Plus

- **MEETS ALL EFFICIENCY REQUIREMENTS OF THE DOE**
- **EXCEEDS ASHRAE 90.1B-1992 EFFICIENCY REQUIREMENTS**
- **ENERGY STAR RATED**
- **NSF 5 CERTIFIED**
- **ULTRA-LOW NOx RATED** – per SCAQMD Rule 1146.2
- **ANSI Z21.10.3 CERTIFIED FOR SAFETY**
- **MEETS ALL REQUIREMENTS OF MASSACHUSETTS PLUMBING BOARD**
- **LEAD FREE** – Per Safe Water Drinking Act SDWA section 1417

SPECIFICATIONS AND APPLICATION DATA

PERFORMANCE

MODELS	NOMINAL CAPACITY (GAL.)	BTU INPUT NAT & LP GAS	THERMAL EFFICIENCY %	GPH RECOVERY @100° RISE	AIR INTAKE/ EXHAUST VENT SIZE	COMBINED INTAKE/EXHAUST VENT LENGTHS	INLET/ OUTLET SIZE	SHIPPING WEIGHT
PH100-55	55	35,000 - 100,000	*0.89	115	2"	85'	1" NPT	175
PH130-55	55	35,000 - 130,000	94	146	2"	85'	1" NPT	175
PH160-55	55	40,000 - 160,000	95	184	3"	200'	1" NPT	175
PH199-55	55	40,000 - 199,000	95	229	3"	200'	1" NPT	175
PH100-80	80	35,000 - 100,000	*0.93	116	2"	85'	1½" NPT	235
PH130-80	80	35,000 - 130,000	95	150	2"	85'	1½" NPT	235
PH160-80	80	40,000 - 160,000	96	184	3"	200'	1½" NPT	235
PH199-80	80	40,000 - 199,000	95	229	3"	200'	1½" NPT	235
PH100-119	119	35,000 - 100,000	*0.9	117	2"	85'	1½" NPT	405
PH130-119	119	35,000 - 130,000	96	152	2"	85'	1½" NPT	405
PH160-119	119	40,000 - 160,000	96	184	3"	200'	1½" NPT	405
PH199-119	119	40,000 - 199,000	96	230	3"	200'	1½" NPT	405
PHM130-80	80	35,000 - 130,000	96	150	2"	85'	1½" NPT	285
PHM199-80	80	40,000 - 199,000	96	229	3"	200'	1½" NPT	285
PHM130-100	100	35,000 - 130,000	96	150	2"	85'	1½" NPT	315
PHM199-100	100	40,000 - 199,000	95	229	3"	200'	1½" NPT	315

* Indicates UEF instead of Thermal Efficiency

DIMENSIONS IN INCHES

MODELS	GALLONS	JACKET DIAMETER A	TOTAL HEIGHT B	OUTLET HEIGHT C	DRAIN HEIGHT D	AIR INTAKE CENTERLINE (FROM REAR) E	EXHAUST VENT CENTERLINE (FROM REAR) F	AIR INTAKE HEIGHT G	GAS CONNECTION HEIGHT H	EXHAUST VENT HEIGHT J	CONDENSATE CONNECTION HEIGHT K	T&P HEIGHT L	FRONT CABINET HEIGHT M	DEPTH N	DRAIN VALVE HEIGHT O	WATER CONNECTIONS DISTANCE P*
PHXXX-55	55	23	54 ¾	46 ½	6 ½	23 ¼	27 ¾	18 ½	17	7 ½	3	46 ½	23 ¼	34 ¾	7 ¼	n/a
PHXXX-80	80	23	74 ¾	67 ¾	7 ¾	27 ½	32	20 ¾	19 ¾	10	3	67 ¾	27"	34 ¾	7 ¼	n/a
PHXXX-119	119	27	74	66 ¾	7 ½	27 ½	32	21 ½	18 ¾	10 ½	3	66 ½	24 ¾	38 ½	7 ¼	n/a
PHMXXX-80	80	27 ½	55	45 ¾	7 ¾	27 ½	32	18 ¾	17	8	3	45 ¾	24 ¾	38 ¾	7 ¼	9 ½
PHMXXX-100	100	27 ½	63	54	7 ¾	27 ½	32	18 ¾	17	8	3	54	24 ¾	38 ¾	7 ¼	9 ½

*Multi-Fit only

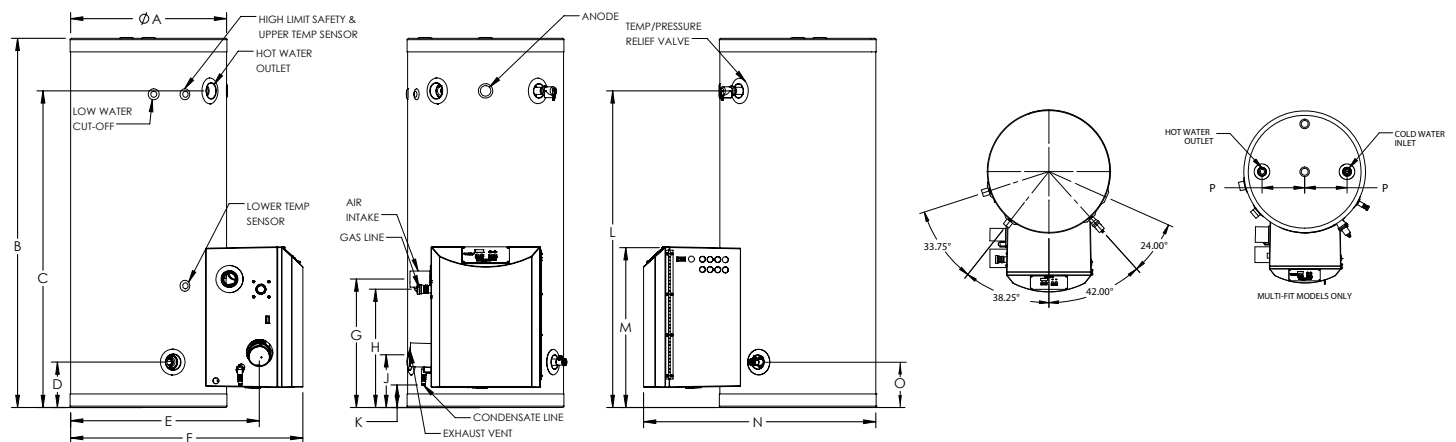

PHOENIX PLUS

Commercial Gas Water Heaters



Features

- **DUAL COMBUSTION SYSTEMS** – provides built in redundancy and load-matching modulation.
- **MODULATING BURNER** – Allows up to a 10:1 turndown ratio to provide the correct amount of power when needed.
- **HIGH EFFICIENCY** – Up to 95% thanks to the modulating-condensing combustion.
- **VARIETY OF POWER INPUTS** – Ranging from 199K to 399K BTU.
- **MAXIMUM DURABILITY** – Tank constructed of high-quality stainless steel with dual cupronickel heat exchangers – combined with an anode rod – ensures years of maintenance-free operation.
- **FRONT COMBUSTION CHAMBER** – Allows for ease of access and servicing of the combustion assembly.
- **INTELLIGENT CONTROLS** – Monitor inlet and outlet water temperatures to automatically adjust modulation and ensure consistent performance.
- **INDOOR AND OUTDOOR INSTALLATION** – durable powder coated steel cabinet allows for versatile installation.
- **VERSATILE VENTING** – Vents in PVC, CPVC, Stainless Steel, and ULC S636 up to 200ft combined intake & exhaust with 4".
- **NATURAL GAS MODELS WITH LP CONVERSION KITS** – Allow for fast conversions and reduced inventory requirements.
- **FULLY AUTOMATIC TEMPERATURE CONTROLS** up to 160° F.
- **LOW-WATER CUT OFF PROBE** factory installed.
- **RECIRCULATION PORT** allows for fast installation of recirculation line.
- **TEMPERATURE AND PRESSURE RELIEF VALVE** – included for easy installation.
- **DURABLE BRASS DRAIN VALVE** – Factory installed for fast and easy draining.
- **GAS CONNECTION** – 3/4" female gas connection on all models.
- **ADDED PROTECTION** – High quality aluminum anode rods to extend tank life.
- **3 YEAR LIMITED TANK WARRANTY / 1 YEAR COMPONENTS**



Globally Recognized. Industry Respected.

Plus

- **MEETS ALL EFFICIENCY REQUIREMENTS OF THE DOE**
- **EXCEEDS ASHRAE 90.1B-1992 EFFICIENCY REQUIREMENTS**
- **NSF 5 CERTIFIED**
- **ULTRA-LOW NOX RATED – PER SCAQMD RULE 1146.2**
- **ANSI Z21.10.3 CERTIFIED FOR SAFETY**
- **MEETS ALL REQUIREMENTS OF MASSACHUSETTS PLUMBING BOARD**
- **LEAD FREE – PER SAFE WATER DRINKING ACT SDWA SECTION 1417**

SPECIFICATIONS AND APPLICATION DATA

MODELS	NOMINAL CAPACITY (GAL)	BTU INPUT NAT & LP GAS	TURN DOWN RATIO	THERMAL EFFICIENCY %	GPH RECOVERY @ 100' RISE	AIR INTAKE/ EXHAUST VENT SIZE	COMBINED INTAKE/ EXHAUST VENT LENGTHS	INLET/ OUTLET SIZE	AUX PORT SIZE	GAS CONNECTION SIZE
PHP199-119	119	40,000 - 199,000	5:1	95	232	3"	200 FT	1-1/2" NPT	1" NPT	3/4" NPT
PHP260-119	119	35,000 - 260,000	10:1	94	303	4"	200 FT	1-1/2" NPT	1" NPT	3/4" NPT
PHP320-119	119	40,000 - 320,000	10:1	94	372	4"	200 FT	1-1/2" NPT	1" NPT	3/4" NPT
PHP399-119	119	40,000 - 399,000	10:1	95	464	4"	200 FT	1-1/2" NPT	1" NPT	3/4" NPT

SPECIFICATIONS AND DIMENSIONS

MODELS	GAS CONNECTION DEPTH A	CONDENSATE DEPTH B	CONDENSATE HEIGHT C	GAS CONNECTION HEIGHT D	CABINET WIDTH E	CABINET HEIGHT F	COLD INLET/AUX WIDTH G	AUX DEPTH H	AUX HEIGHT J	SHIPPING WEIGHT
PHP199-119	11-3/16"	5-1/2"	7"	42-1/8"	32"	77"	16"	9-3/4"	49"	475
PHP260-119	11-3/16"	5-1/2"	7"	42-1/8"	32"	85"	16"	9-3/4"	58-3/4"	555
PHP320-119	11-3/16"	5-1/2"	7"	42-1/8"	32"	85"	16"	9-3/4"	58-3/4"	575
PHP399-119	11-3/16"	5-1/2"	7"	42-1/8"	32"	85"	16"	9-3/4"	58-3/4"	575

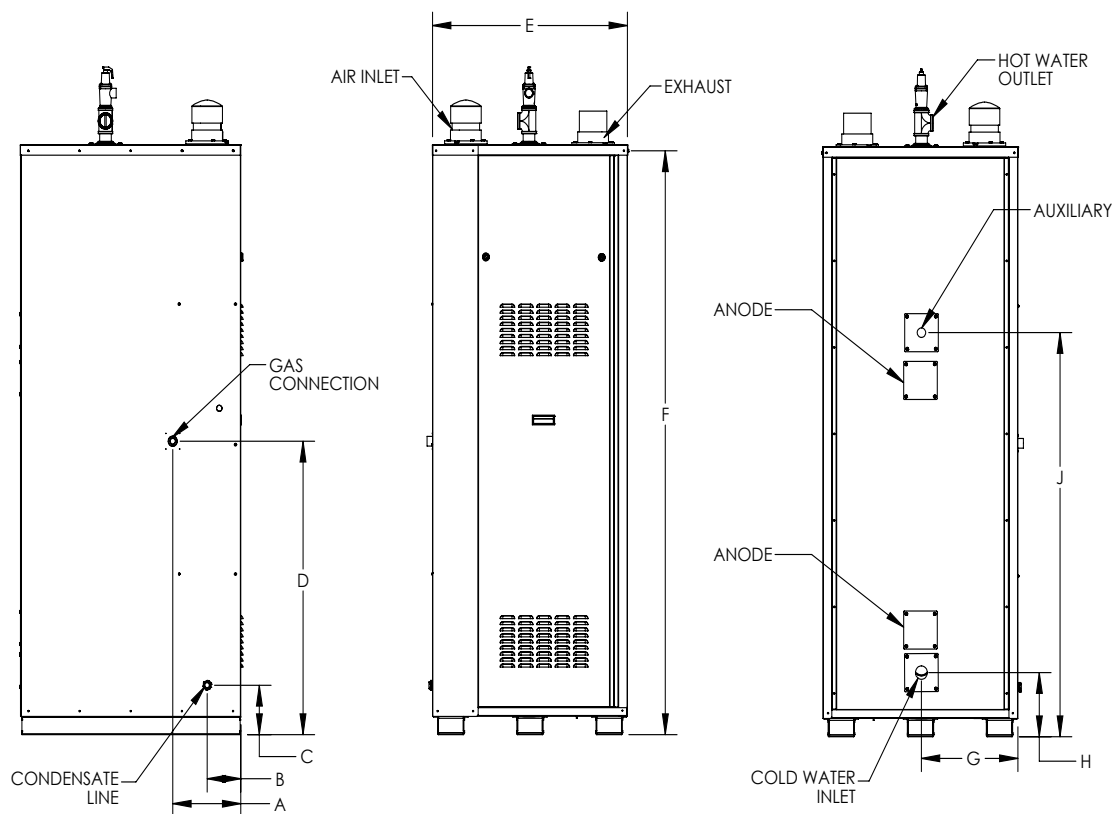

ELITE XL VWH

Volume Water Heaters



Features

- **WIDE RANGE OF INPUTS** - 7 Input options from 399,000 TO 2,000,000 BTU
- **EASY TO CONTROL** - 7" high resolution touch screen display makes checking or changing parameters easier than ever.
- **HTP LINK** - WiFi solution enables remote monitoring of the appliance and system
- **ASME CONSTRUCTION** - 316L stainless steel construction pressure rated at 160 PSI with ASME (H) stamp
- **4 PASS HEAT EXCHANGER** - large internal circuits reduce pressure drop allowing the use of smaller pumps, reducing the cost of installation.
- **BLUE JET COMBUSTION** - unique design low-nox burner technology which provides a uniform stable flame for years of trouble-free operation, while avoiding clogging and hot spots normally seen on premix burners.
- **FOOTMASTER WHEELS** - standard on all 399k-1M models, allows moving the unit and locking it in place easy
- **REMOVABLE FRONT AND SIDE PANELS** - allows access to all internal components and makes servicing a breeze.
- **CASCADE SEQUENCING** - up to 8 volume water heaters for redundancy of operation (no downtime), providing even larger turn down ratios while increasing overall system efficiency and performance with unit run time rotation.
- **VERSATILE VENTING** - Direct vent up to 150 ft (1.5M - 2.0M) and up to 125ft (399k - 1M) using PVC, CPVC, Polypropylene, or Stainless Steel.

Performance

- UP TO 98% THERMAL EFFICIENCY
- 10:1 TURN DOWN RATIO
- AHRI CERTIFIED AND LISTED

Quality

- STAINLESS STEEL WATER TUBE HEAT EXCHANGER
- LIMITED 5 YEAR WARRANTY / 1 YEAR COMPONENTS



Globally Recognized. Industry Respected.

HTP LINK

Multiple Platforms on the Cloud

Technical Support

Remotely link to a factory technician to assist in system monitoring, troubleshooting and overall system efficiency.

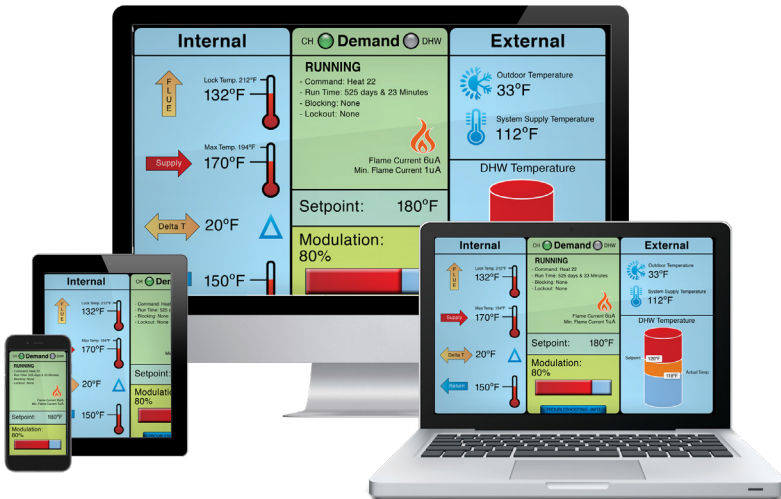

Building / Property Manager

Remotely link to monitor multiple units in multiple locations. Get text and email alerts to critical system events such as faults. Continuous system monitoring optimizes system performance and efficiency.



Contractor / Maintenance

Receive text and email notifications and remotely link to assist the customer with system issues. Get key information to quickly and efficiently troubleshoot before arriving on the job.



The HTP Link Touch Display

Take Total Control of Your Heating System

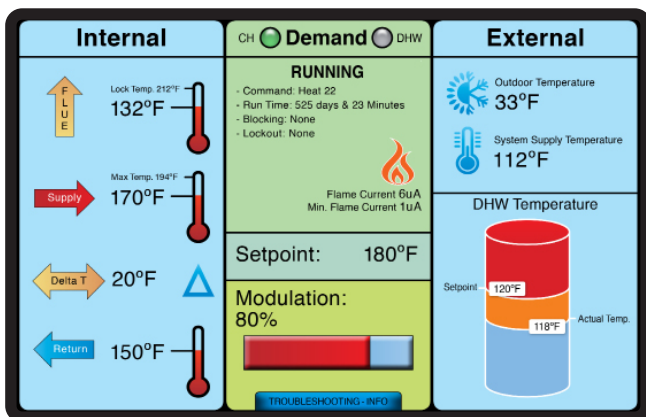

Each Elite XL comes with a High Resolution 7" Touchscreen

TOUCHSCREEN DISPLAY

7" High Resolution color touchscreen display provides clear visual monitoring of the unit's parameters and programming to maximize the efficiency of the unit. Display screen color will change to help clearly identify the status of the unit, making monitoring and troubleshooting easy.

Stand-By/Running (Green Color)
 Fault (Red Color)
 Blocking Code (Yellow Color)

Model ELX-		400FVWHN	500FVWHN	650FVWHN	800FVWHN	1000FVWHN	1500FVWHN	2000FVWHN
Installation		Indoor, Floor Standing, Fully Condensing						
Minimum / Maximum Input (Btu/Hr)		39,900 / 399,000	50,000 / 500,000	65,000 / 650,000	80,000 / 800,000	100,000 / 1,000,000	150,000 / 1,500,000	200,000 / 2,000,000
Heating Capacity (MBH)		387	485	630	776	970	1,455	1,940
Flue System		Category IV, Sealed Combustion Direct Vent, Power Vent						
Minimum Combined Vent Run		10 feet					15 feet	
Maximum Combined Vent Run		4" (125 feet)		6" (125 feet)			8" (150 feet)	
Approved Exhaust Vent Materials		PVC, CPVC, PP, Stainless Steel						
Packaging Dimensions (in Inches)	W	32.25					43.25	
	H	49.625					64.25	
	D	48		64			76	86
Shipping Weight (lbs)		538	545	680	700	745	1400	1750
Gas Supply Pressure		3.5" to 14" WC (NG or LP)						3.5" to 10.5" WC (NG ONLY)
Manifold Pressure	Min / Max	-0.08" WC (NG or LP)						-0.07" WC (NG ONLY)
Power Supply		120V 60 Hz, 6.3A						208/3PH WYE, 60Hz, 10A/Leg
Customer Connection Board Fuse Amperage Ratings		2 Amps						5 Amps
General Operating Conditions		Minimum Ambient Temperature: 32°F (0°C) Product Approvals and Requirements: ANSI Z21.13 / CSA 4.9, CSD-1 ASME Code						
Ignition System		Direct Electronic Spark Ignition / Flame Rectification						
Burner System		Premixed Fuel Modulation / Stainless Steel Burner						
Gas Valve System		Pneumatic Gas Valve						
Dimensions (in Inches)	W	26					31.8	
	H	41					60.8	
	D	40.7		56.5			66.5	79
VWH Water Content (Gallons)		3.8	4.3	5.6	6.6	8.1	12.9	16.25
Minimum Flow Rate @ 20°F ΔT at Low Fire (GPM)		4	5	6.5	8	10	15	20
DHW Setpoint Temperature Range		70 – 185°F						
Water Pressure (PSI)	Heat Exchanger MAWP	160						
	Temperature & Pressure Relief Valve	Temperature: 210F / Pressure: 150						
Connection Sizes	Supply / Return	2" NPT					2 1/2" Flange	
	Gas Inlet	1" NPT			1 1/4" NPT		1 1/2" NPT	2" NPT
Materials	Cabinet	Powder Coated Galvaneal Steel						
	Heat Exchanger	316L Stainless Steel Water Tube						
Safety Devices		Flame Rectifier Probe, Dual Water Supply Temperature Sensor / High Limit (210°F), Freeze Protection, Condensate Trap with Float, Dual Flue Sensor (210°F), Blocked Vent Pressure Switch, Internal UL 353 Approved Low Water Cut-Off (LWCO), High Resolution Flow Switch						

Model	Water Connection	Vent Size	Air Intake	Gas Connection	Condensate
ELX-400VWHN - ELX-500VWHN	2" NPT	4"	4"	1"	3/4" PVC
ELX-650VWHN		6"	6"	1"	
ELX-800VWHN - ELX-1000VWHN		1-1/4"			
ELX-1500VWHN	2 1/2" Flange	8"	8"	1-1/2"	1" PVC
ELX-2000VWHN				2"	

Model	A	B	C	D	E	F	G	H	J	K	L	M	N	O	P	Q	R
ELX-400FVWHN/ ELX-500FVWHN	41.0	26.0	40.7	17.9	35.0	4.1	10.1	10.5	12.6	16.1	20.5	22.0	6.1	8.1	25.8	35.0	2.8*
ELX-650FVWHN - ELX-1000FVWHN			56.5														
ELX-1500FVWHN	60.8	31.8	66.5	39.2	44.8	51.2	3.4	7.4	7.5	11.9	14.4	24.4	31.8	4.6	6.5	22.7	39.1
ELX-2000FVWHN			79.0														

399,000 to 1,000,000 Btuh Units

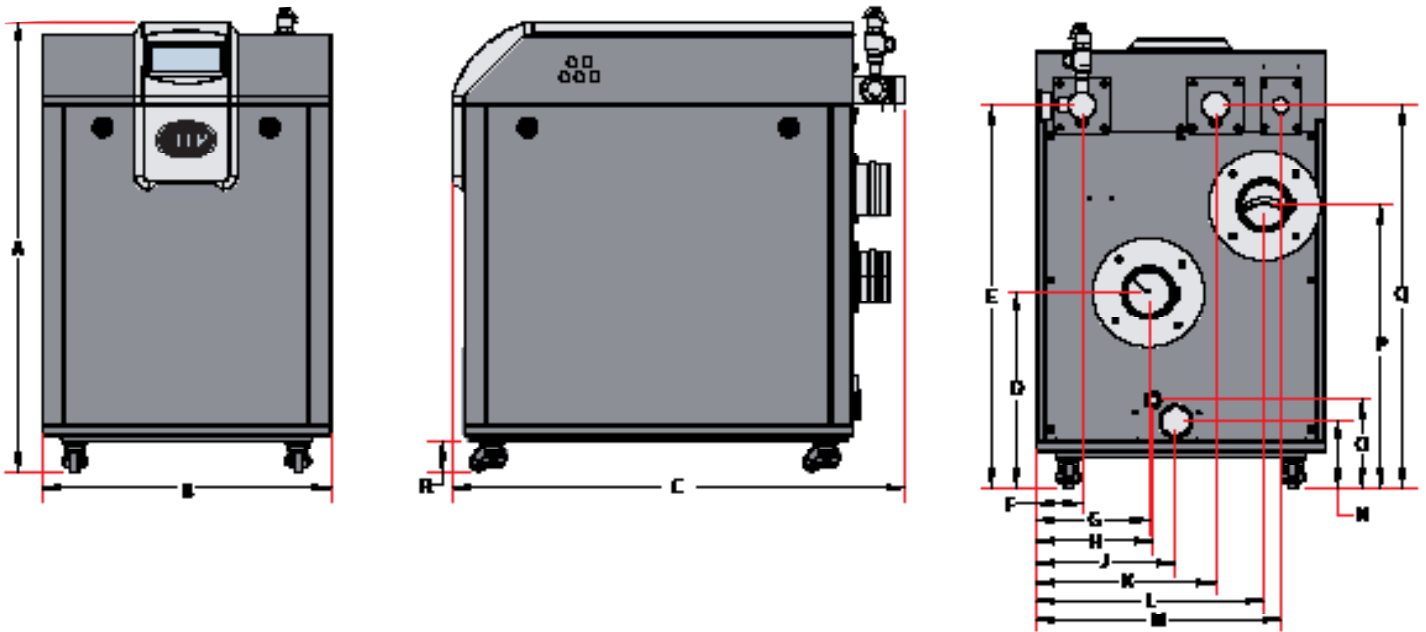

1,500,000 to 2,000,000 Btuh Units

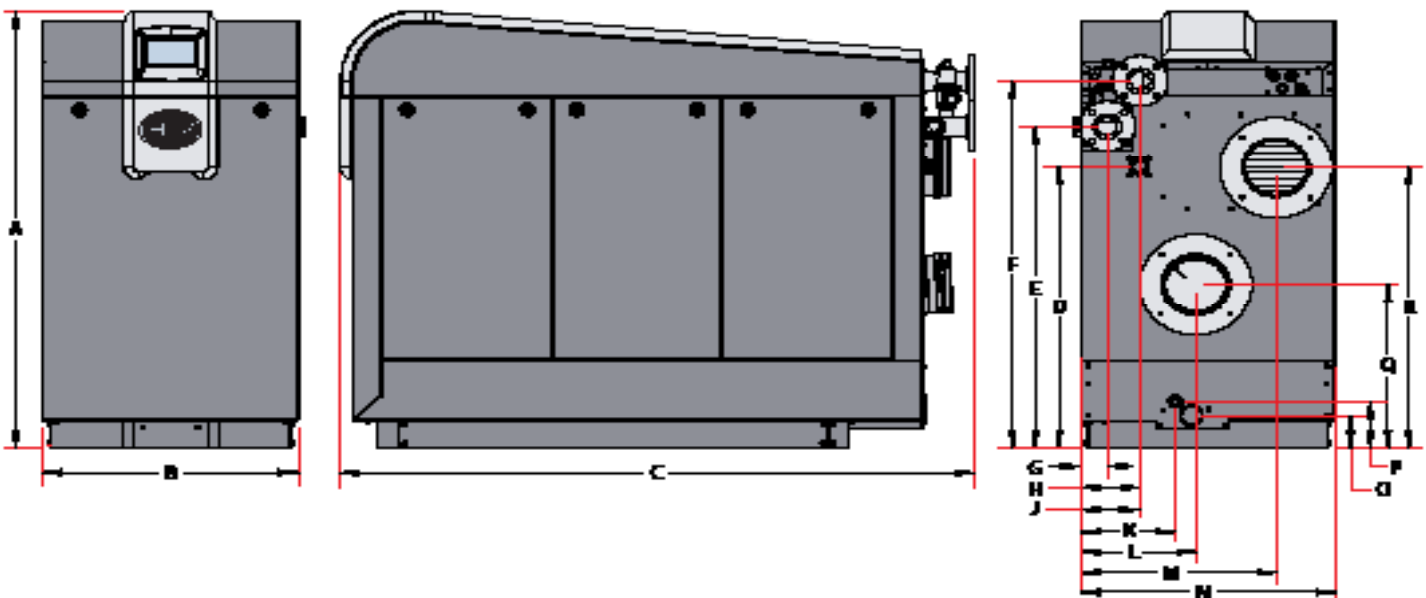

SUPERSTOR ULTRA MAX

Indirect Water Heaters



Features

- **STAINLESS STEEL** tank constructed of high-quality, lightweight stainless steel making it easier to handle than glass-lined water heaters.
- **SUPERFLEX HEAT EXCHANGER** Lightweight, corrugated stainless steel heat exchanger allows the coil to flex, minimizing scale buildup and prolonging tank life.
- **TOP CONNECTIONS** for cold inlet, hot outlet, and relief valve make installation easy.
- **DAILY SCHEDULING** set up daily scheduling to ensure hot water is available when needed most.
- **FULLY AUTOMATIC SURFACE MOUNTED THERMOSTAT** for controlling the temperature, combined with a manual energy cut-off to prevent overheating.
- **INLET DIPTUBE** injects cold water into the bottom of the tank to ensure only the hottest water is drawn from the top of the tank.
- **TEMPERATURE AND PRESSURE RELIEF VALVE** – Included for ease of installation.
- **DURABLE BRASS DRAIN VALVE** – Included for ease of installation.

Performance

- **IMPROVED FIRST HOUR RATING**
- **EXTREMELY LOW PRESSURE DROP**
- **UP TO 50% MORE HOT WATER THAN MANY WATER HEATERS OF SIMILAR SIZE.**
- **ENVIRONMENTALLY SAFE CFC FOAM 2+ INCHES OF SUPER FOAM INSULATION FOR LOW STANDBY LOSS**
- **NSF 5 CERTIFIED**

Quality

- **316L STAINLESS STEEL TANK**
- **316L CORRUGATED STAINLESS STEEL HEAT EXCHANGER**
- **NO ANODE ROD NEEDED**
- **LIMITED LIFETIME TANK WARRANTY* FOR RESIDENTIAL USE / 1 YEAR COMPONENTS**
- **5 YEAR TANK WARRANTY FOR COMMERCIAL USE / 1 YEAR COMPONENTS**



MULTI-SOURCE INDIRECT MODELS AVAILABLE WITH ELECTRIC BACKUP

*With online registration. See product warranty for details.

SPECIFICATIONS AND APPLICATION DATA

MODELS	NOMINAL CAPACITY (GAL.)	HEAT EXCHANGER SURFACE (SQ.FT.)	TEST PRESSURE (PSI)	WORKING PRESSURE (PSI)	180° F BOILER WATER FIRST HOUR RATING*	180° F BOILER BTUH / SIZE	RECOMMENDED FLOW RATE (GPM)	PRESSURE DROP AT RECOMMENDED FLOW RATE (FT. OF HEAD)	DHW INLET AND OUTLET PORT SIZES	BOILER INLET AND OUTLET PORT SIZES
MSSU-30N	30	15	300	150	286	170,000	14	5.4	3/4" NPT MALE	1" NPT FEMALE
MSSU-45N	30	15	300	150	317	185,000	14	5.4	3/4" NPT MALE	1" NPT FEMALE
MSSU-60N	30	15	300	150	340	185,000	14	5.4	1" NPT MALE	1" NPT FEMALE
MSSU-80N	30	18	300	150	405	215,000	14	2	1" NPT MALE	1" NPT FEMALE
MSSU-119N	119	18	300	150	433	215,000	14	2	1-1/2" NPT MALE	1" NPT FEMALE

+AHRI TEST METHOD BASED ON 77° F TEMPERATURE RISE, 58° F / 135° F W/BOILER WATER AT 180° F NOTE: TANK RECOVERY FROM COLD START WILL BE BETWEEN 10-13 MINUTES WHEN SIZED WITH CORRECT FLOW RATE, BOILER SIZE AND PRESSURE DROP RATINGS FROM LIST IN ABOVE CHART.
 CONTINUOUS FLOW RATING CALCULATION: FIRST HOUR RATING - (.75 * GALLON CAPACITY) = CONTINUOUS FLOW RATING.

DIMENSIONS & WEIGHT

MODEL	PRODUCT HEIGHT A	PRODUCT DIAMETER B	COIL OUTLET & DRAIN C	COIL INLET D	INLET/OUTLET HEIGHT E	WATER CONNECTIONS DISTANCE F	SHIPPING WEIGHT LBS
MSSU-30N	42-1/8"	19-3/8"	5-7/8"	21"	1-3/8"	8"	58
MSSU-45N	54-1/4"	19-3/8"	5-7/8"	21"	1-3/8"	8"	70
MSSU-60N	52-5/8"	23-1/2"	5-7/8"	21"	1-3/8"	8"	105
MSSU-80N	69"	23-1/2"	5-7/8"	21"	1-3/8"	8"	135
MSSU-119N	69"	27-1/2"	8-1/8"	20-1/4"	1-3/8"	8"	190

SUPERSTOR ULTRA MAX SERIES

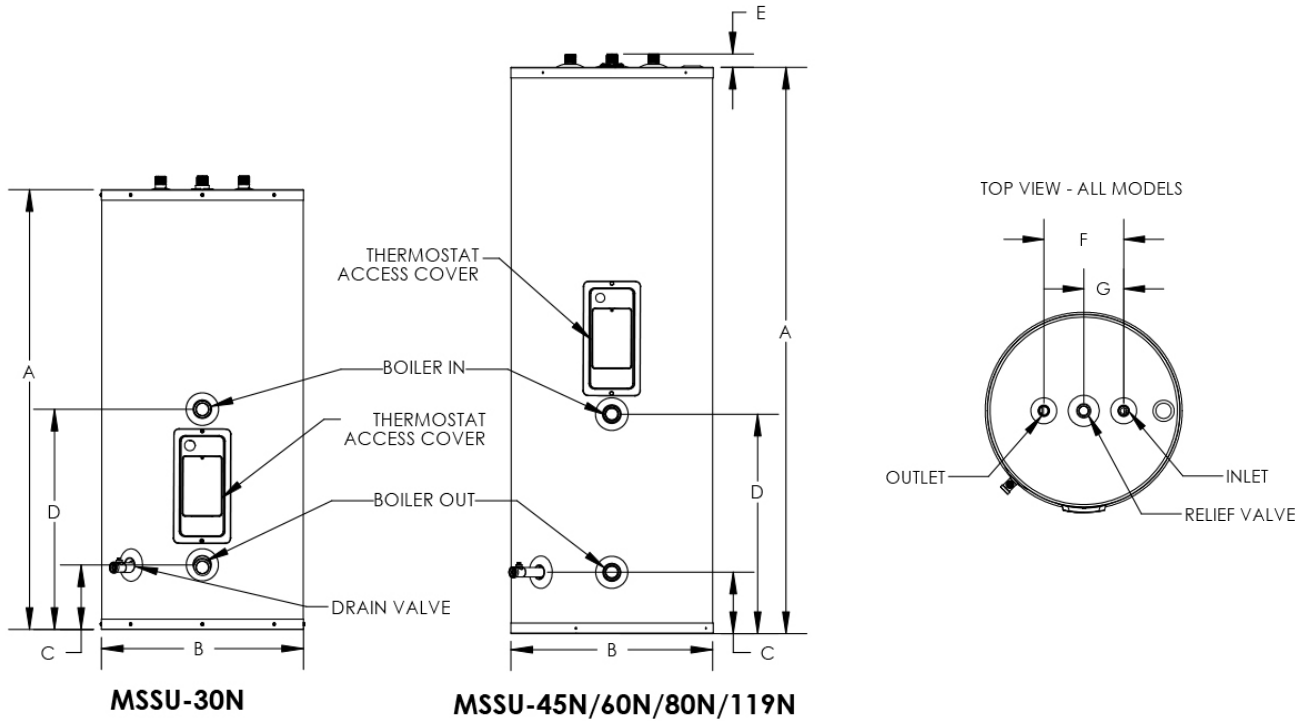

SUPERSTOR ULTRA

Indirect Water Heaters



Features

- **STAINLESS STEEL** tank constructed of high-quality, lightweight stainless steel making it easier to handle than glass-lined water heaters.
- **CUPRONICKEL HEAT EXCHANGER** high output finned heat exchanger maximizes efficiency with 11 fins per inch of tube.
- **IMMERSION CONTROL WELL** stainless steel sensor well provides accurate temperature control.
- **DURABLE BRASS DRAIN VALVE** – included for ease of installation.

Performance

- **UP TO 50% MORE HOT WATER THAN MANY WATER HEATERS OF SIMILAR SIZE.**
- **ENVIRONMENTALLY SAFE CFC FOAM 2+ INCHES OF SUPER FOAM INSULATION FOR LOW STANDBY LOSS**
- **NSF 5 CERTIFIED**

Quality

- **316L STAINLESS STEEL TANK**
- **CUPRONICKEL FINNED HEAT EXCHANGER**
- **NO ANODE ROD NEEDED**
- **LIMITED LIFETIME TANK WARRANTY* FOR RESIDENTIAL USE / 1 YEAR COMPONENTS**
- **5 YEAR TANK WARRANTY FOR COMMERCIAL USE / 1 YEAR COMPONENTS**



*With online registration. See product warranty for details.

SPECIFICATIONS AND APPLICATION DATA

MODEL	NOMINAL CAPACITY (GAL)	HEAT EXCHANGER SURFACE (SQ.FT.)	TEST PRESSURE (PSI)	WORKING PRESSURE (PSI)	180° F BOILER WATER FIRST HOUR RATING* (GPH)		RECOMMENDED FLOW RATE (GPM)	PRESSURE DROP AT RECOMMENDED FLOW RATE (FT. OF HEAD)	DHW INLET AND OUTLET PORT SIZES	BOILER INLET AND OUTLET PORT SIZES
					140F	115F				
SSU-20N	20	15	300	150	121	168	8	6	3/4" NPT MALE	1" NPT MALE
SSU-30N	30	15	300	150	154	212	8	6	3/4" NPT MALE	1" NPT MALE
SSU-30LBN	30	15	300	150	169	234	8	6	3/4" NPT MALE	1" NPT MALE
SSU-45N	45	20	300	150	212	292	10	7.9	3/4" NPT MALE	1" NPT MALE
SSU-60N	60	20	300	150	266	370	10	7.9	3/4" NPT MALE	1" NPT MALE
SSU-80N	80	34	300	150	330	440	12	9.1	1-1/2" NPT MALE	1" NPT MALE
SSU-119N	119	34	300	150	423	564	14	11.3	1-1/2" NPT MALE	1" NPT MALE

*DOE TEST METHOD BASED ON 90 F TEMPERATURE RISE, 50 /140 W/BOILER WATER AT 180 F

SPECIFICATIONS AND DIMENSIONS

MODELS	DHW INLET, DRAIN, & COIL OUTLET A	COIL INLET B	DHW HOT OUTLET C	PRODUCT HEIGHT D	PRODUCT DIAMETER E	SHIPPING WEIGHT LBS
SSU-20N		9-3/4"	22"	27"	19-1/4"	51
SSU-30N	5-1/4"	9-3/4"	34"	39-1/2"	19-1/4"	62
SSU-30LBN	5-1/4"	9-3/4"	22"	28-1/2"	23-1/4"	71
SSU-45N	5-1/4"	9-3/4"	46"	52-1/2"	19-1/4"	72
SSU-60N	5-1/4"	9-3/4"	46"	52-1/2"	23-1/4"	109
SSU-80N	6"	29"	64-3/4"	72"	23-1/4"	143
SSU-119N	7-1/4"	30-1/4"	66"	74"	27"	212

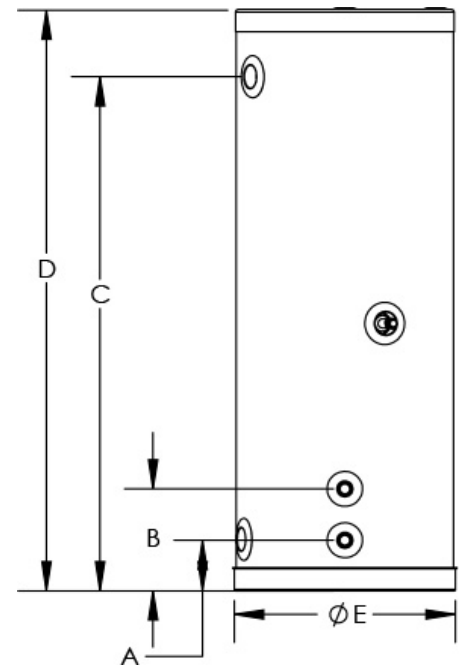

SSU MAX MULTI-SOURCE

Indirect Water Heaters



Features

- **STAINLESS STEEL** tank constructed of high-quality, lightweight stainless steel making it easier to handle than glass-lined water heaters.
- **SUPERFLEX HEAT EXCHANGER** Lightweight, corrugated stainless steel heat exchanger allows the coil to flex, minimizing scale buildup and prolonging tank life.
- **TOP CONNECTIONS** for cold inlet, hot outlet, and relief valve make installation easy.
- **DAILY SCHEDULING** set up daily scheduling to ensure hot water is available when needed most.
- **FULLY AUTOMATIC SURFACE MOUNTED THERMOSTAT** for controlling the temperature, combined with a manual energy cut-off to prevent overheating.
- **INLET DIPTUBE** injects cold water into the bottom of the tank to ensure only the hottest water is drawn from the top of the tank.
- **TEMPERATURE AND PRESSURE RELIEF VALVE** – Included for ease of installation.
- **DURABLE BRASS DRAIN VALVE** – Included for ease of installation.

Performance

- **IMPROVED FIRST HOUR RATING**
- **EXTREMELY LOW PRESSURE DROP**
- **UP TO 50% MORE HOT WATER THAN MANY WATER HEATERS OF SIMILAR SIZE.**
- **ENVIRONMENTALLY SAFE CFC FOAM 2+ INCHES OF SUPER FOAM INSULATION FOR LOW STANDBY LOSS**
- **NSF 5 CERTIFIED**

Quality

- **316L STAINLESS STEEL TANK**
- **316L CORRUGATED STAINLESS STEEL HEAT EXCHANGER**
- **NO ANODE ROD NEEDED**
- **LIMITED LIFETIME TANK WARRANTY* FOR RESIDENTIAL USE / 1 YEAR COMPONENTS**
- **5 YEAR TANK WARRANTY FOR COMMERCIAL USE / 1 YEAR COMPONENTS**



MULTI-SOURCE INDIRECT MODELS AVAILABLE WITH ELECTRIC BACKUP

*With online registration. See product warranty for details.

SPECIFICATIONS AND APPLICATION DATA

MODELS	NOMINAL CAPACITY (GAL)	HEAT EXCHANGER VOLUME (GALLONS)	WATER VOLUME OF BACKUP (GALLONS)	HEAT EXCHANGER SURFACE (SQ.FT.)	TEST PRESSURE (PSI)	WORKING PRESSURE (PSI)	RECOVERY OF BACK-UP IN MINUTES* (GALLONS)		FIRST DRAW** (GALLONS)	180° F BOILER BTUH / SIZE	RECOMMENDED FLOW RATE (GPM)	PRESSURE DROP AT RECOMMENDED FLOW RATE (FT. OF HEAD)	DHW INLET AND OUTLET PORT SIZES	BOILER INLET AND OUTLET PORT SIZES
							65 F RISE	90 F RISE						
MSSU-80NSE	80	1	22	18	300	150	63	85	405	215,000	14	2	3/4" NPT MALE	3/4" NPT MALE
MSSU-115NSE	119	1	32	18	300	150	84	112	433	215,000	14	2	3/4" NPT MALE	3/4" NPT MALE

*NOTE: Recovery was tested with no input to coil.

**NOTE: First draw was acquired by heating the entire tank until thermostat was satisfied, then drawing until a Delta T of 15oF was seen at the outlet

DIMENSIONS & WEIGHT

MODEL	PRODUCT HEIGHT	PRODUCT DIAMETER	COIL OUTLET	COIL INLET	INLET/OUTLET HEIGHT	T&P HEIGHT	T&P HEIGHT	SHIPPING WEIGHT LBS
	A	B	C	D	E	F	F	
MSSU-80N	69"	23-1/2"	7-1/4"	21-1/2"	2-1/2"	60-1/4"	8"	160
MSSU-119N	69"	27	7-1/4"	21-1/2"	2-1/2"	60-1/4"	8"	235

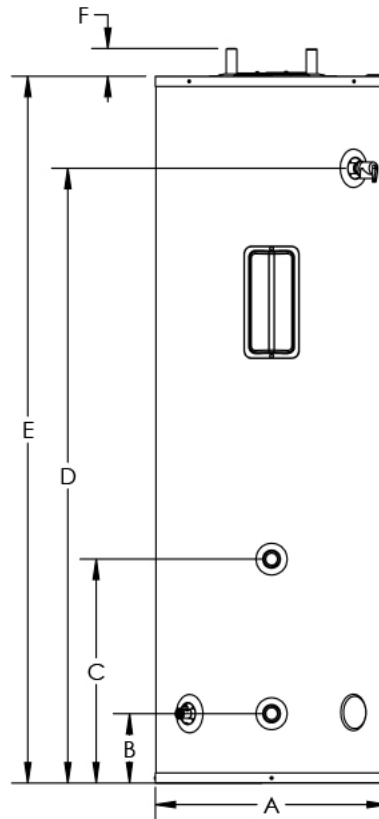

SUPERSTOR ULTRA COMMERCIAL

Indirect Water Heaters



Features

- **STAINLESS STEEL** tank constructed of high-quality, lightweight stainless steel making it easier to handle than glass-lined water heaters.
- **DUAL CUPRONICKEL HEAT EXCHANGERS** two high output finned heat exchanger maximize efficiency with 11 fins per inch of tube.
- **IMMERSION CONTROL WELL** stainless steel sensor well provides accurate temperature control.
- **TEMPERATURE AND PRESSURE RELIEF VALVE** included for ease of installation.
- **DURABLE BRASS DRAIN VALVE** included for ease of installation .

Performance

- **UP TO 50% MORE HOT WATER THAN MANY WATER HEATERS OF SIMILAR SIZE.**
- **ENVIRONMENTALLY SAFE CFC FOAM 2+ INCHES OF SUPER FOAM INSULATION FOR LOW STANDBY LOSS**
- **NSF 5 CERTIFIED**

Quality

- **316L STAINLESS STEEL TANK**
- **CUPRONICKEL FINNED HEAT EXCHANGERS**
- **NO ANODE ROD NEEDED**
- **7 YEAR TANK WARRANTY FOR COMMERCIAL USE / 1 YEAR COMPONENTS**



SPECIFICATIONS AND APPLICATION DATA

MODELS	NOMINAL CAPACITY (GAL.)	HEAT EXCHANGER SURFACE (SQ.FT.)	TEST PRESSURE (PSI)	WORKING PRESSURE (PSI)	180° F BOILER WATER FIRST HOUR RATING* (GPH)		RECOMMENDED FLOW RATE (GPM)	PRESSURE DROP AT RECOMMENDED FLOW RATE (FT. OF HEAD)	DHW INLET AND OUTLET PORT SIZES	BOILER INLET AND OUTLET PORT SIZES
					140F	140F				
SSU-60CN	60	40	300	150	354	467	22	9.2	1" NPT MALE	1" NPT FEMALE
SSU-80CN	80	68	300	150	490	647	24	10	1" NPT MALE	1" NPT FEMALE
SSU-119CN	119	68	300	150	637	841	28	12.7	1-1/2" NPT MALE	1" NPT FEMALE

*DOE TEST METHOD BASED ON 90 F TEMPERATURE RISE, 50 /140 W/BOILER WATER AT 180 F

DIMENSIONS & WEIGHT

MODEL	DHW INLET, DRAIN, & COIL OUTLET A	COIL OUTLET B	COIL INLET C	COIL OUTLET D	DHW OUTLET/T&P HEIGHT E	PRODUCT HEIGHT F	PRODUCT DIAMETER G	SHIPPING WEIGHT LBS
SSU-60CN	5-1/4"	9-3/4"	14"	18.75"	46"	52-1/2"	23-1/4"	126
SSU-80CN	6"	N/A	N/A	29"	64-3/4"	72"	23-1/4"	175
SSU-119CN	7-1/4"	N/A	N/A <td 30-1/4"	66"	74"	27"	242	

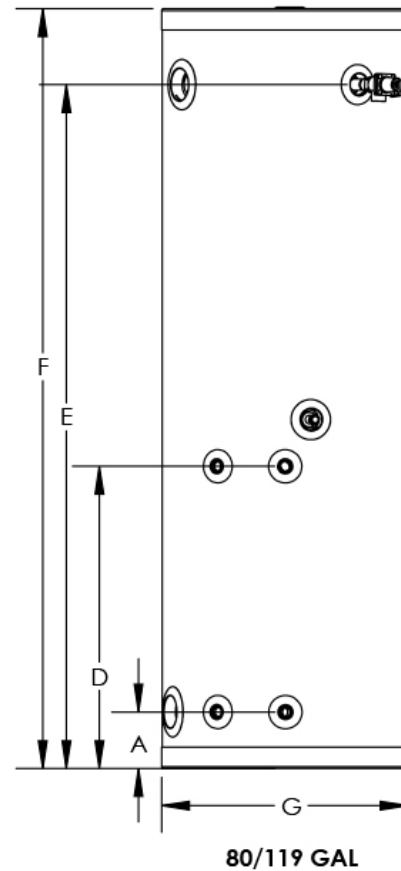
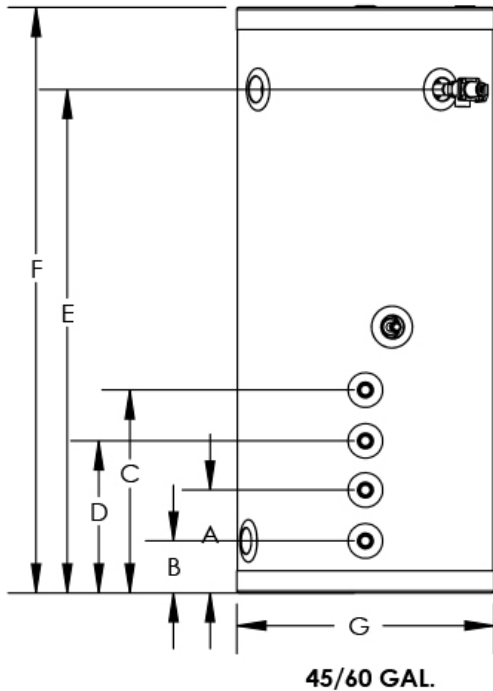

SUPERSTOR CONTENDER TITANIUM

Indirect Water Heaters



Features

- **TITANIUM INFUSED GLASS LINING** on tank and heat exchanger to reduce corrosion, tolerate high temperatures, and extend tank life.
- **TOP CONNECTIONS** for inlet, outlet, supply, return, and relief valve make installation easy.
- **INLET DIPTUBE** injects cold water into the bottom of the tank to ensure only the hottest water is drawn from the top of the tank.
- **DURABLE JACKET** constructed of powder coated steel jacket.
- **½" SCREW IN IMMERSION WELL** stainless steel sensor well included for ease of installation.
- **AQUASTAT** for controlling the temperature.
- **TEMPERATURE AND PRESSURE RELIEF VALVE** included for ease of installation.
- **DURABLE BRASS DRAIN VALVE** included for ease of installation.

Performance

- **UP TO 50% MORE HOT WATER THAN MANY WATER HEATERS OF SIMILAR SIZE**
- **ENVIRONMENTALLY SAFE CFC FOAM 2+ INCHES OF SUPER FOAM INSULATION FOR LOW STANDBY LOSS**

Quality

- **TITANIUM GLASS LINED STEEL TANK AND HEAT EXCHANGER**
- **MAGNESIUM ANODE ROD**
- **LIMITED LIFETIME TANK WARRANTY* FOR RESIDENTIAL USE / 6 YEAR COMPONENT**
- **5 YEAR TANK WARRANTY FOR COMMERCIAL USE / 1 YEAR COMPONENT**



*With online registration. See product warranty for details.

SPECIFICATIONS AND APPLICATION DATA

MODELS	NOMINAL CAPACITY (GAL.)	DOERATED CAPACITY (GAL.)	MAX WORKING TEMPERATURE	WORKING PRESSURE (PSI)	180° F BOILER WATER FIRST HOUR RATING*	180° F BOILER BTUH / SIZE	RECOMMENDED FLOW RATE (GPM)	PRESSURE DROP AT RECOMMENDED FLOW RATE (FT. OF HEAD)	DHW INLET AND OUTLET PORT SIZES	BOILER INLET AND OUTLET PORT SIZES
SSC-20TC	20	21.2	200 F	150	92	75,000	5	1.2	3/4" NPT MALE	3/4" NPT MALE
SSC-32TC	32	31.7	200 F	150	109	95,000	8	3.8	3/4" NPT MALE	3/4" NPT MALE
SSC-40TC	40	42.3	200 F	150	125	115,000	12	7.6	3/4" NPT MALE	3/4" NPT MALE
SSC-50TC	50	52.9	200 F	150	190	140,000	12	8.8	3/4" NPT MALE	3/4" NPT MALE

*AHRI TEST METHOD BASED ON 77° F TEMPERATURE RISE, 58° F / 135° F W/BOILER WATER AT 180° F NOTE: TANK RECOVERY FROM COLD START WILL BE BETWEEN 10-13 MINUTES WHEN SIZED WITH CORRECT FLOW RATE, BOILER SIZE AND PRESSURE DROP RATINGS FROM LIST IN ABOVE CHART.
 CONTINUOUS FLOW RATING CALCULATION: FIRST HOUR RATING - (.75 * GALLON CAPACITY) = CONTINUOUS FLOW RATING.
 WHEN SIZED WITH CORRECT FLOW RATE, BOILER SIZE AND PRESSURE DROP RATINGS FROM LIST IN ABOVE CHART.
 CONTINUOUS FLOW RATING CALCULATION: FIRST HOUR RATING - (.75 * GALLON CAPACITY) = CONTINUOUS FLOW RATING.

DIMENSIONS & WEIGHT

MODEL	PRODUCT DIAMETER A	PRODUCT DIAMETER B	TOP FITTING HEIGHT C	AQUASTAT HEIGHT D	DHW WATER CONNECTIONS DISTANCE E	BOILER CONNECTIONS DISTANCE F	BOILER CONNECTIONS DEPTH G	DHW CONNECTIONS DEPTH H	SHIPPING WEIGHT (LBS)
SSC-20TC	22"	28.7"	27"	14 1/2"	4 3/4"	11 3/4"	3 3/4"	6"	252
SSC-32TC	22"	37"	35 1/4"	18 1/4"	4 3/4"	11 3/4"	3 3/4"	6"	363
SSC-40TC	22"	45 1/4"	43 1/2"	18 1/4"	4 3/4"	11 3/4"	3 3/4"	6"	465
SSC-50TC	22"	54"	52 1/4"	22 1/4"	4 3/4"	11 3/4"	3 3/4"	6"	577

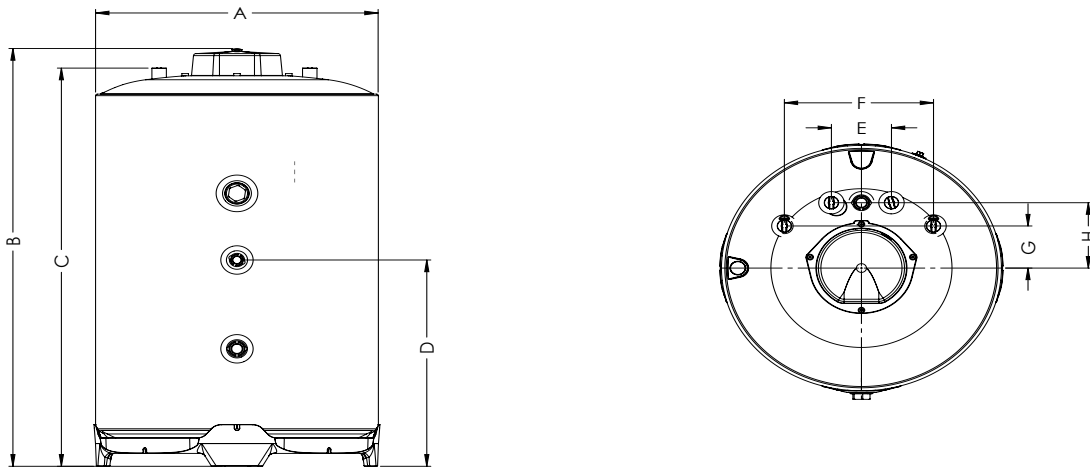

SUPERSTOR CONTENDER

Indirect Water Heaters



Features

- **GLASS LINED STEEL TANK** and heat exchanger to reduce corrosion and extend tank life.
- **TOP CONNECTIONS** for inlet and outlet for easy installation.
- **INLET DIPTUBE** injects cold water into the bottom of the tank to ensure only the hottest water is drawn from the top of the tank.
- **FULLY AUTOMATIC SURFACE MOUNTED THERMOSTAT** for controlling the temperature.
- **1" NPT SUPPLY AND RETURN CONNECTIONS** on all models.
- **TEMPERATURE AND PRESSURE RELIEF VALVE** included for ease of installation.
- **DURABLE BRASS DRAIN VALVE** included for ease of installation.

Performance

- **LOW PRESSURE DROP**
- **UP TO 50% MORE HOT WATER THAN MANY WATER HEATERS OF SIMILAR SIZE.**
- **ENVIRONMENTALLY SAFE CFC FOAM 2+ INCHES OF SUPER FOAM INSULATION FOR LOW STANDBY LOSS**

Quality

- **GLASS LINED STEEL TANK AND HEAT EXCHANGER**
- **MAGNESIUM ANODE ROD• NO ANODE ROD NEEDED**
- **7 YEAR TANK WARRANTY FOR RESIDENTIAL USE / 1 YEAR COMPONENT**
- **5 YEAR TANK WARRANTY FOR COMMERCIAL USE / 1 YEAR COMPONENT**



SPECIFICATIONS AND APPLICATION DATA

MODELS	NOMINAL CAPACITY (GAL.)	MAX WORKING TEMPERATURE	WORKING PRESSURE (PSI)	BOILER GROSS OUTPUT (BTU/H)	140 F 90 ΔT	127 F 77 ΔT	115 F 65 ΔT	RECOMMENDED FLOW RATE (GPM)	PRESSURE DROP AT RECOMMENDED FLOW RATE (FT. OF HEAD)	DHW INLET AND OUTLET PORT SIZES	BOILER INLET AND OUTLET PORT SIZES
SSC-80	80	200 F	150	91,000	198	221	270	10	5.5	1-1/2" NPT MALE	1" NPT MALE
SSC-119	119	200 F	150	108,000	268	300	364	12	14.6	1-1/2" NPT MALE	1" NPT MALE

*DOE TEST METHOD BASED ON 90 F TEMPERATURE RISE, 50 /140 W/BOILER WATER AT 180 F

DIMENSIONS & WEIGHT

MODEL	COIL INLET	COIL OUTLET	DRAIN HEIGHT	PRODUCT HEIGHT	PRODUCT DIAMETER	WATER CONNECTIONS DISTANCE	SHIPPING WEIGHT LBS
	A	B	C	D	E	F	
SSC-80	42 -1/8"	19-3/8"	5-7/8"	21"	1-3/8"	8"	232
SSC-119	54-1/4"	19-3/8"	5-7/8"	21"	1-3/8"	8"	300

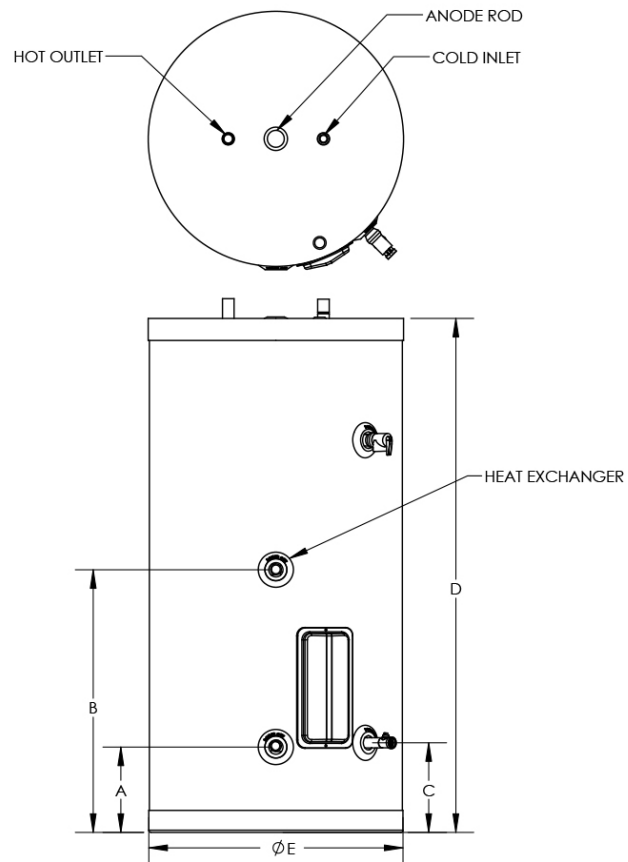

SUPERSTOR STAINLESS STORAGE

Storage Tanks



Features

- **STAINLESS STEEL** tank constructed of high-quality, lightweight stainless steel making it easier to handle than glass-lined water heaters.
- **FULLY AUTOMATIC SURFACE MOUNTED THERMOSTAT** for controlling the temperature.

Performance

- **ENVIRONMENTALLY SAFE CFC FOAM 2+ INCHES OF SUPER FOAM INSULATION FOR LOW STANDBY LOSS**

Quality

- **316L STAINLESS STEEL TANK**
- **NO ANODE ROD NEEDED**
- **10 YEAR TANK WARRANTY FOR RESIDENTIAL AND COMMERCIAL USE**



SPECIFICATIONS AND APPLICATION DATA

MODELS	NOMINAL CAPACITY (GAL.)	WORKING PRESSURE (PSI)	CONNECTION SIZES
SSU-20CBN	20	150	3/4" NPT MALE
SSU-30CBN	30	150	3/4" NPT MALE
SSU-45CBN	45	150	3/4" NPT MALE
SSU-60CBN	60	150	3/4" NPT MALE
SSU-80CBN	80	150	1-1/2" NPT MALE
SSU-119CBN	119	150	1-1/2" NPT MALE

DIMENSIONS & WEIGHT (NON-ASME)

MODEL	PRODUCT DIAMETER A	COLD WATER/DRAIN B	CIRCULATING PORT TOP C	OUTLET/T&P HEIGHT D	PRODUCT HEIGHT E	CONTROL WELL HEIGHT F	SHIPPING WEIGHT LBS
SSU-20CBN	19-1/4"	4-1/2"	14-1/2"	HEIGHT	27-1/2"	N/A	25
SSU-30CBN	19-1/4"	4-1/2"	14-1/2"	D	39-1/2"	N/A	40
SSU-45CBN	19-1/4"	4-1/2"	14-1/2"	45-3/4"	59-1/2"	N/A	64
SSU-60CBN	23-1/4"	4-1/2"	14-1/2"	45-3/4"	52-1/2"	N/A	90
SSU-80CBN	23-1/4"	6"	???	64-3/4"	72"	16"	129
SSU-119CBN	27"	7-1/4"	???	66"	73-1/2"	17-1/4"	178

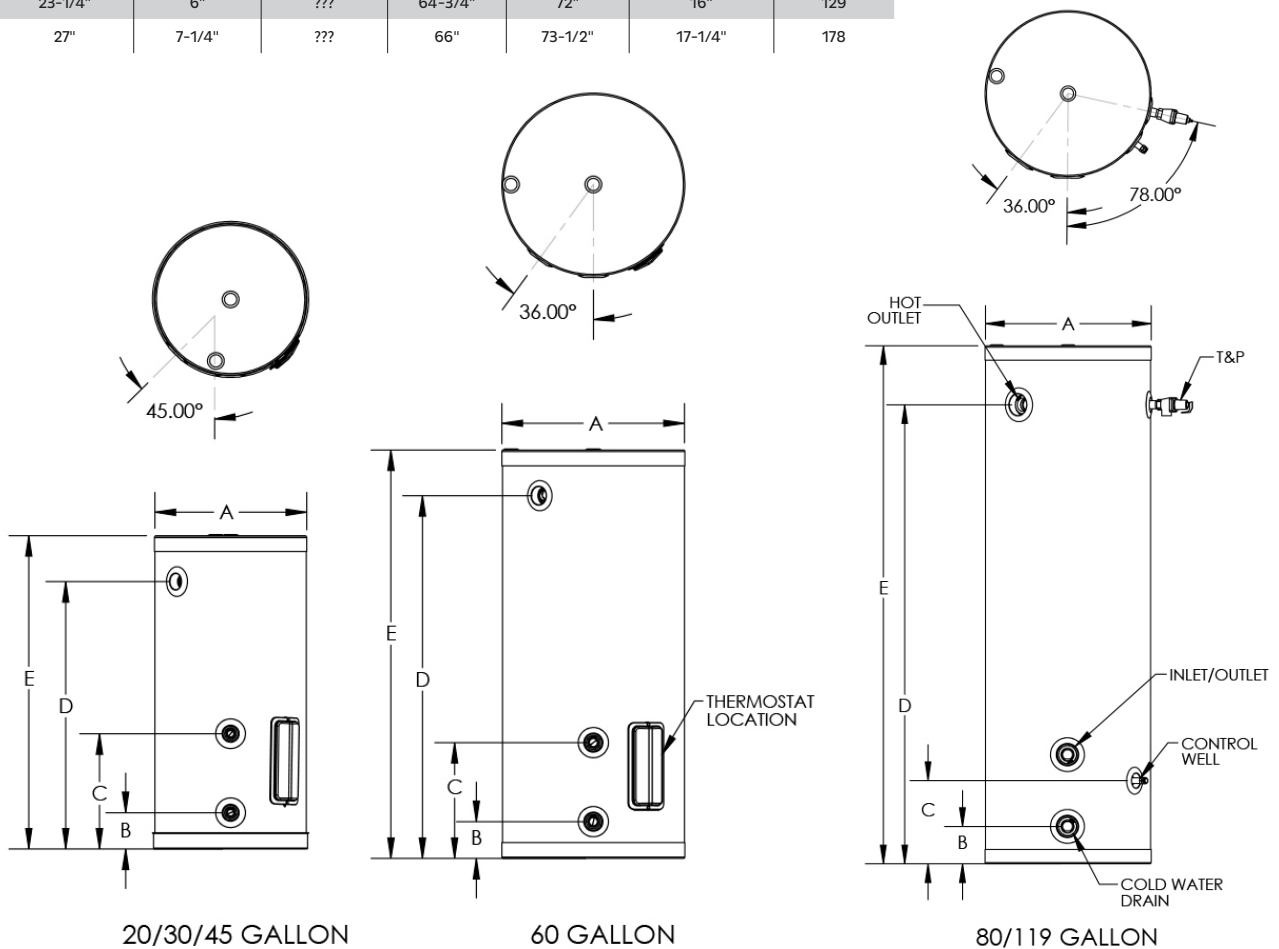

SUPERSTOR GLASS LINED STORAGE

Storage Tanks



Features

- **DURABLE GLASS LINED STEEL TANK** constructed of thick steel.
- **FULLY AUTOMATIC SURFACE MOUNTED THERMOSTAT** for controlling the temperature.

Performance

- **MEET OR EXCEED THE EFFICIENCY REQUIREMENTS OF ASHRAE STANDARD 90.1B-2001.**
- **ENVIRONMENTALLY SAFE CFC FOAM 1.5+ INCHES OF SUPER FOAM INSULATION FOR LOW STANDBY LOSS**

Quality

- **DURABLE GLASS LINED TANK**
- **DUAL MAGNESIUM ANODE ROD to prolong tank life**
- **5 YEAR TANK WARRANTY FOR RESIDENTIAL USE**



SPECIFICATIONS AND APPLICATION DATA

MODELS	NOMINAL CAPACITY (GAL.)	WORKING PRESSURE (PSI)	HOT OUTLET (TOP)	FRONT CONNECTIONS
GL-50	50	150	3/4" NPT MALE	3/4" NPT MALE
GL-80	80	150	2" NPT MALE	2" NPT MALE
GL-119	119	150	2" NPT MALE	2" NPT MALE

DIMENSIONS & WEIGHT

MODEL	PRODUCT HEIGHT	PRODUCT DIAMETER	CIRCULATING PORT TOP	CIRCULATING PORT BOTTOM	T&P HEIGHT	SHIPPING WEIGHT LBS
	A	B	C	D	E	
GL-50	19-1/4"	52"	14"	7"	45"	120
GL-80	23-1/4"	59"	13"	7"	51-1/4"	165
GL-119	28"	64"	13"	4"	55"	250

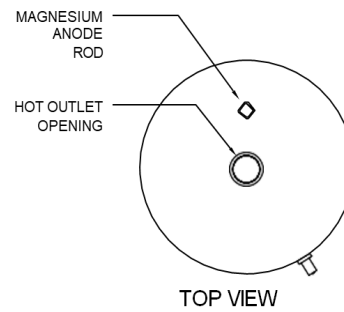
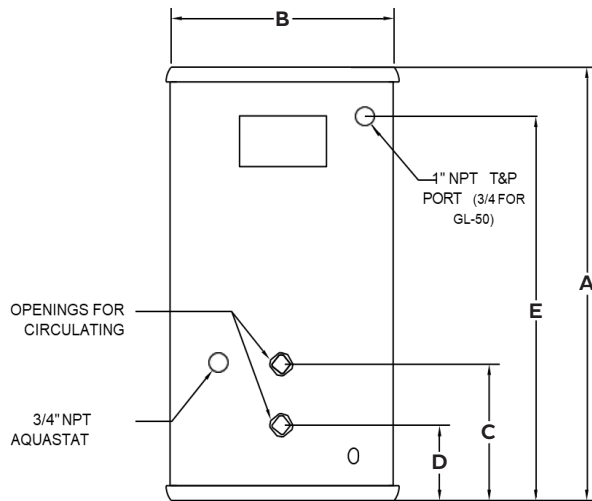



225 Dyer Street, Providence, RI 02903
Toll Free (800) 323-9651 • htproducts.com

MKTLIT-210 5.15.24