

REZNOR®**MODEL X****INDOOR, GAS-FIRED, GRAVITY-VENTED DUCT FURNACE FOR COMMERCIAL/
INDUSTRIAL USE****DESCRIPTION**

Reznor X Series Duct Furnaces are designed to provide **80% thermal efficiency** for indoor application with gravity venting. They are certified for use with natural or propane gas, as specified, in sizes from 75,000 through 400,000 BTUH input. These models are used as heating components in heating, heating/cooling, or makeup air systems and require a separate blower system for air delivery. The furnace has a Reznor Thermocore® aluminized steel heat exchanger with venturi-design tubes. The die-formed burners are of aluminized steel and include flared ports with a stainless steel insert.

The Model X furnace is approved for a temperature rise of 50°F to 90°F and includes “finger-baffles” for proper air distribution at these lower air volumes. Removing the finger-baffles increases the air flow. These field converted units are approved for a temperature rise of 20°F to 75°F.

Standard features include a spark ignition pilot and a single-stage, 24-volt gas valve. Model X units are wired for field connection to a remote 24-volt thermostat for automatic operation. Each unit is provided with all required limit and safety controls, including a blocked vent shut-off system.

STANDARD FEATURES

- Orifices for natural gas
- Aluminized steel heat exchanger
- Aluminized steel burners with stainless steel insert
- 120-volt supply voltage
- 24 volt control voltage transformer
- High limit safety cutout
- Single-stage combination gas valve (see note 1)
- Side access for burners and controls (left side facing air stream)
- Horizontal or vertical flue discharge
- Spark-ignited pilot
- Fan control
- Terminal blocks for connecting field wiring
- Blocked vent shut-off system

**OPTIONAL FEATURES -
FACTORY INSTALLED**

- Unit equipped for propane gas
- E-3 (409) stainless steel heat exchanger (see note 2)
- E-3 (409) stainless steel burners (see note 2)
- E-3 (409) stainless steel drip pan (see note 2)
- Gas Controls
 - ◆ Spark-ignited intermittent safety pilot with electronic flame supervision
 - ◆ Spark-ignited intermittent safety pilot with electronic flame supervision and timed lockout
 - ◆ Two-stage controls
 - ◆ Electronic modulation - 50%-100% firing rate
- Burner air shutters (required on units equipped with propane gas)
- 208/230/460-volt alternate supply voltage
- Right side controls (facing airstream)

NOTES:

1. Regulated combination redundant gas valve consists of combination pilot solenoid valve, electric gas valve, pilot filter, pressure regulator, pilot shut-off, and manual shut-off, all in one body. Gas supply pressure must not exceed 0.5 PSI (8 oz. - 14" w.c.). Minimum inlet pressure for natural gas is 5" w.c. Minimum inlet pressure for propane gas is 11" w.c.
2. For air inlet temperatures below 40°F or temperature rise less than 40°F, an optional stainless steel heat exchanger is recommended.
3. See temperature rise and pressure drop tables.
4. Blower must be placed on entering side of furnace.
5. Approved for installation downstream of an air conditioning coil (optional drain flange, stainless steel heat exchanger, and stainless steel burners are recommended).
6. Not approved for residential use.

REZNOR®**MODEL X (cont'd)****INDOOR, GAS-FIRED, GRAVITY-VENTED DUCT FURNACE FOR COMMERCIAL/
INDUSTRIAL USE****OPTIONAL FEATURES -
FIELD INSTALLED**

- Single-stage thermostat
- Two-stage thermostat
- Electronic room override (makeup air applications only)
- Thermostat guard with locking cover
- Manual shut-off valve and union
- Power venter with venter adapter
- Condensate drain flange kit
- Disconnect switch (UL Listed)

TECHNICAL DATA

Model X	Size	75	100	125	150	175	200	225	250	300	350	400
Input Heating Capacity	BTUH	75,000	100,000	125,000	150,000	175,000	200,000	225,000	250,000	300,000	350,000	400,000
	(kW)	(22.0)	(29.3)	(36.6)	(44.0)	(51.3)	(58.6)	(65.9)	(73.3)	(87.9)	(102.6)	(117.2)
Output Heating Capacity (80%) ^A	BTUH	60,000	80,000	100,000	120,000	140,000	160,000	180,000	200,000	240,000	280,000	320,000
	(kW)	(17.6)	(23.4)	(29.3)	(35.2)	(41.0)	(46.9)	(52.8)	(58.6)	(70.3)	(82.1)	(93.8)
Full Load Amps (115V)		0.2	0.2	0.2	0.2	0.2	0.2	0.2	0.2	0.2	0.2	0.2
Unit Control Amps (24V)		0.3	0.3	0.3	0.3	0.3	0.3	0.3	0.3	0.3	0.3	0.3
Air Volume w/ Finger-Baffles	cfm	610-1,105	815-1,475	1,020-1,840	1,225-2,210	1,430-2,580	1,635-2,945	1,840-3,315	2,045-3,685	2,455-4,420	2,865-5,160	3,275-5,895
	(m ³ /hr)	(1,036-1,877)	(1,385-2,506)	(1,733-3,126)	(2,081-3,755)	(2,429-4,383)	(2,778-5,003)	(3,126-5,632)	(3,474-6,261)	(4,171-7,509)	(4,867-8,767)	(5,564-10,015)
Air Volume w/o Finger-Baffles ^B	cfm	735-2,765	980-3,685	1,225-4,605	1,475-5,530	1,720-6,450	1,965-7,370	2,210-8,295	2,455-9,215	2,945-11,060	3,440-12,900	3,930-14,745
	(m ³ /hr)	(1,249-4,698)	(1,665-6,261)	(2,081-7,824)	(2,506-9,395)	(2,922-10,958)	(3,338-12,521)	(3,755-14,093)	(4,171-15,656)	(5,003-18,790)	(5,844-21,916)	(6,677-25,051)
Net Weight	lbs	150	150	163	182	186	224	231	276	286	320	355
	(kg)	(68)	(68)	(74)	(83)	(84)	(102)	(105)	(125)	(130)	(145)	(161)
Ship Weight	lbs	170	170	200	220	230	275	290	350	360	390	420
	(kg)	(77)	(77)	(91)	(100)	(104)	(125)	(132)	(159)	(163)	(177)	(191)
Gas Connection (in.) Natural ^C		1/2"	1/2"	1/2"	1/2"	1/2"	1/2"	1/2"	1/2"	3/4"	3/4"	3/4"
Flue Size		5" Rd.	6" Rd.	7" Ov.	8" Ov.	8" Ov.	8" Rd.	8" Rd.	10" Ov.	10" Ov.	12" Ov.	12" Ov.

^A In U.S. ratings are for altitudes to 2,000 feet. Above 2,000 feet derate by orifice change, 4% for each 1,000 feet above sea level.

In Canada ratings are for altitudes to 2,000 feet. For high altitude units (2,001-4,500 ft.) derate by 10% of maximum input.

^B For high air volume the finger-baffles in the heat exchanger section are removed during unit installation. See installation manual for instructions.

^C Sizes shown are for natural gas connections and are applicable to single stage gas valves, NOT supply line size. Propane gas connection is 1/2" for all sizes.



MODEL X (cont'd)

INDOOR, GAS-FIRED, GRAVITY-VENTED DUCT FURNACE FOR COMMERCIAL/ INDUSTRIAL USE

DIMENSIONS

±1/8" (3mm)

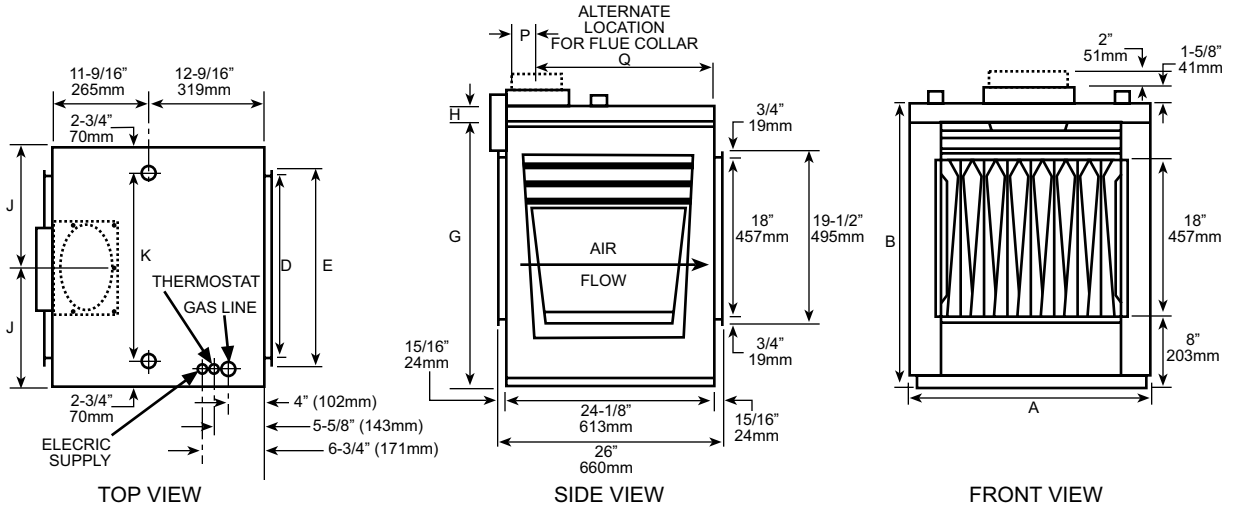

SIZE		A	B	D	E	G	H	J	K	P	Q
75	in.	19 1/4	32 1/4	12 1/2	14	30 1/4	2	9 5/8	13 3/4	3 1/2	20 3/4
	(mm)	(489)	(819)	(318)	(356)	(768)	(51)	(244)	(349)	(89)	(527)
100	in.	19 1/4	32 1/4	12 1/2	14	30 1/4	2	9 5/8	13 3/4	3 1/2	20 3/4
	(mm)	(489)	(819)	(318)	(356)	(768)	(51)	(244)	(349)	(89)	(527)
125	in.	22	32 1/4	15 1/4	16 3/4	30 1/4	2	11	16 1/2	3 1/2	20 3/4
	(mm)	(559)	(819)	(387)	(425)	(768)	(51)	(279)	(419)	(89)	(527)
150, 175	in.	27 1/2	32 1/4	20 3/4	22 1/4	30 1/4	2	13 3/4	22	3 1/2	20 3/4
	(mm)	(699)	(819)	(527)	(565)	(768)	(51)	(349)	(559)	(89)	(527)
200, 225	in.	33	35 1/4	26 1/4	27 3/4	31 3/4	3 1/2	16 1/2	27 1/2	5	19 1/4
	(mm)	(838)	(895)	(667)	(705)	(806)	(89)	(419)	(699)	(127)	(489)
250, 300	in.	41 1/4	35 1/4	34 1/2	36	31 3/4	3 1/2	20 5/8	35 3/4	5	19 1/4
	(mm)	(1,048)	(895)	(876)	(914)	(806)	(89)	(524)	(908)	(127)	(489)
350	in.	46 3/4	35 1/4	40	41 1/2	31 3/4	3 1/2	23 3/8	41 1/4	5	19 1/4
	(mm)	(1,187)	(895)	(1,016)	(1,054)	(806)	(89)	(594)	(1,048)	(127)	(489)
400	in.	52 1/4	35 1/4	45 1/2	47	31 3/4	3 1/2	26 1/8	46 3/4	5	19 1/4
	(mm)	(1,327)	(895)	(1,156)	(1,194)	(806)	(89)	(664)	(1,187)	(127)	(489)

CLEARANCE FROM COMBUSTIBLES

- Top, flue connections, side opposite controls - 6" (152mm)
- Control side - unit width plus 6" (152mm)
- Bottom - 3" (76mm)

NOTES

1. Burner and control access shown left hand side. Specify right hand for opposite access and connections (Option AJ2).
2. Standard air flow as shown. Direction of air flow may be reversed by field relocation of air baffles.
3. See power venting arrangement section for more information.