

PRODUCT SPECIFICATIONS

Bulletin No. ZGA/ZGB-036-074-50HZ (2/2017)

Z-SERIESTM

DESIGNED TO FIT. FAST.

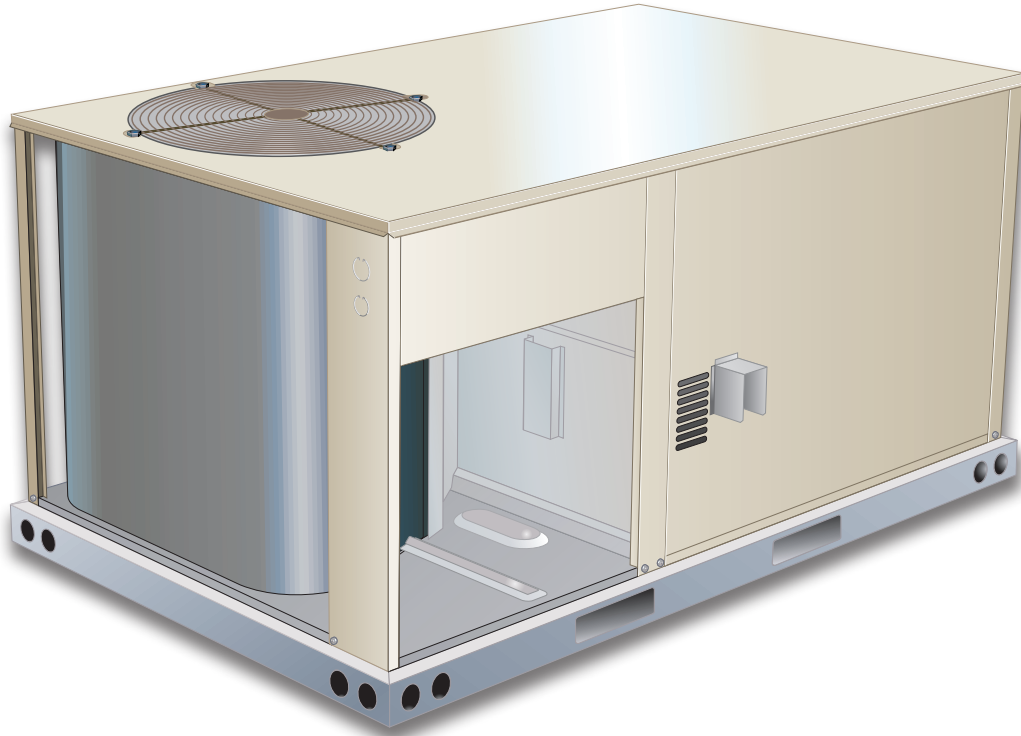

10.5 to 21 kW (3 to 6 Tons)
Net Cooling Capacity – 8.6 to 17.1 kW (29 200 to 58 400 Btuh)
Gas Input Heat Capacity – 16.7 to 38.7 kW (57 000 to 132 000 Btuh)

MODEL NUMBER IDENTIFICATION

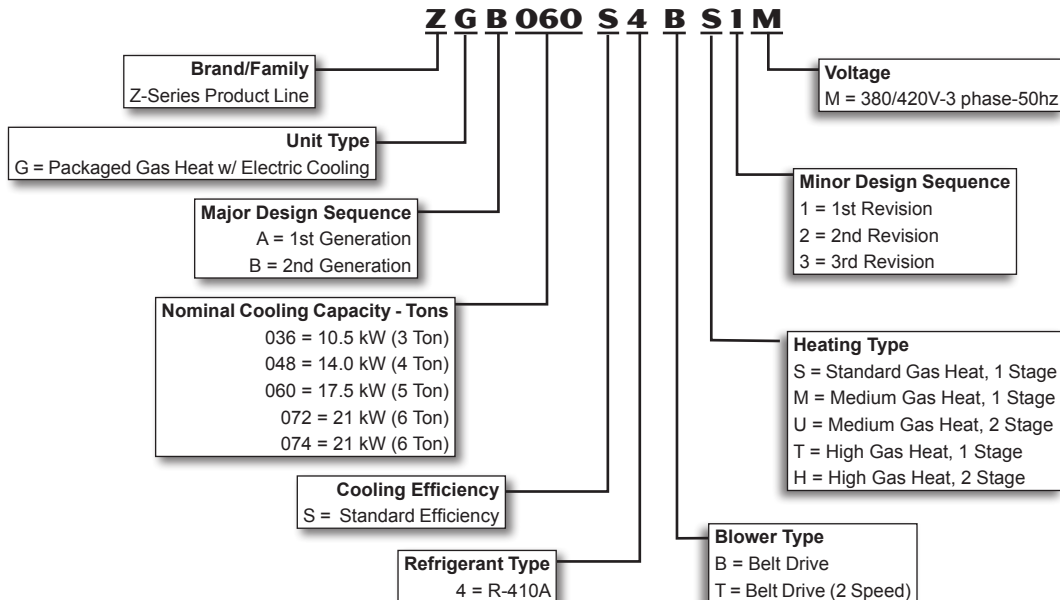

FEATURES AND BENEFITS

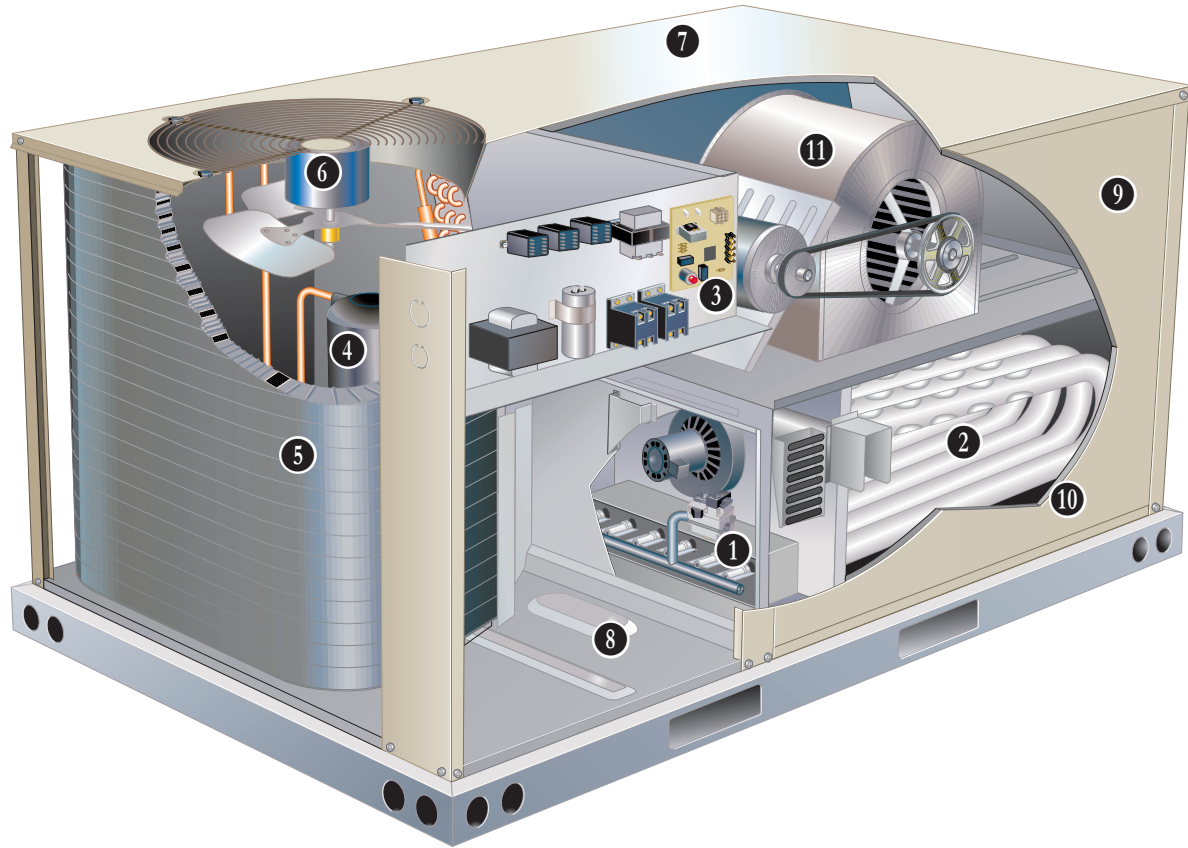

Z-Series rooftop units from Allied are the new standard for cost efficient, reliable rooftop units built for long-lasting performance that can significantly improve indoor environments. Z-Series rooftop units feature:

- **Quick and Easy Retrofit** - Fast installation for replacement of many existing rooftop units - fits high volume competitor's roof curbs.
- **R-410A Refrigerant** - Environmentally friendly.
- **Single Speed Scroll Compressor** - Furnished on all ZGA and ZGB036 through 060 models.
- **Two-Stage Scroll Compressor** - Furnished on all ZGB074 models. Allows rooftop units to deliver just the necessary amount of cooling needed to meet the space's demand. **Eco-last™** Coil System - Smaller, lighter condenser coil.
- **High Pressure Switch** - Protects compressor.
- **Belt Drive Blower Motor** - To maximize air performance.
- **Downflow or Horizontal Airflow** - Easy field conversion.
- **Two Fork Lift Slots on Three Sides** - Easy to pick up and transport units from almost any angle.
- **Corrosion-Resistant Drain Pan** - Provides application flexibility, durability and improved serviceability.
- **Common Components** - Many maintenance items are standard throughout the entire product line, reducing the need to carry different parts to the job or maintain in inventory.

FEATURES AND BENEFITS

CONTENTS

Blower Data	19
Dimensions - Accessories.	43
Dimensions - Unit - ZGA	41
Dimensions - Unit - ZGB	42
Features And Benefits	2
High Altitude Derate.	13
Model Number Identification	1
Optional Conventional Temperature Control Systems	39
Options / Accessories.	9
Outdoor Sound Data	40
Ratings - ZGA.	14
Ratings - ZGB.	16
Specifications - Gas Heat.	13
Specifications - ZGA	11
Specifications - ZGB	12
Unit Clearances.	38
Weight Data.	40

TESTING

Components bonded for grounding to meet safety standards for servicing required by Underwriters Laboratories (UL) and the International Electrotechnical Commission (IEC).

Cooling performance is rated at test conditions included in Air-Conditioning, Heating and Refrigeration Institute (AHRI) Standards 210/24-02008 (10.5 to 17.5 kW models) and 340/360-2007 (21 kW models) while operating at rated voltage and air volumes.

International Organization for Standardization (ISO) 9001 Registered Manufacturing Quality System.

HEATING SYSTEM

- 1 **Aluminized steel inshot burners**, direct spark ignition, electronic flame sensor, combustion air inducer, redundant automatic single or dual stage gas valve with manual shut-off.
- 2 **Heat Exchanger**
Tubular construction, aluminized steel, life cycle tested.
- 3 **Electronic Pilot Ignition**
Electronic spark igniter provides positive direct ignition of burners on each operating cycle. The system permits main gas valve to stay open only when the burners are proven to be lit. Should a loss of flame occur, the gas valve closes, shutting off the gas to the burners. Ignition module has LED to indicate status and aid in troubleshooting.
Watchguard circuit on module automatically resets ignition controls after one hour of continuous thermostat demand after unit lockout, eliminating nuisance service calls. Ignition control is factory installed in the controls section.

Limit Controls

Factory installed, redundant limit controls with fixed temperature setting.

Heat limit controls protect heat exchanger and other components from overheating.

Safety Switches

Flame roll-out switch, flame sensor and combustion air inducer proving switch protect system operation.

Required Selections

Gas Input Choice - Order one:

- Standard Gas Heat (1 Stage) 16.7 kW (57 000 Btuh)
- Medium Gas Heat (1 Stage) 27.8 kW (95 000 Btuh)
- Medium Gas Heat (2 Stage) 20.8/27.8 kW (71 000/95 000 Btuh)
- High Gas Heat (1 Stage) 38.7 kW (132 000 Btuh)
- High Gas Heat (2 Stage) 29.0/38.7 kW (99 000/132 000 Btuh).

Options / Accessories

Field Installed

Propane Kits

Conversion kit to field change over units from Natural Gas to Propane.

Vertical Vent Extension Kit

Use to exhaust flue gases vertically above unit. Required when unit vent is too close to fresh air intakes per building codes. The vent kit also prevents ice formation on intake louvers.

FEATURES AND BENEFITS

COOLING SYSTEM

Designed to maximize sensible and latent cooling performance at design conditions.

System can operate from 2°C to 52°C without any additional controls.

R-410A Refrigerant

Non-chlorine based, ozone friendly, R-410A.

Unit is factory pre-charged with refrigerant. See Specifications Table.

4 Single Speed Scroll Compressor (All ZGA 036 through 060 Models)

Resiliently mounted on rubber grommets for quiet operation.

Scroll compressors for high performance, reliability and quiet operation.

Copeland Scroll Ultra Tech™ Two-Stage Compressor (ZGB074 Models)

Two-stage scroll compressors for increased part load efficiency, high performance, reliability and quiet operation.

Resiliently mounted on rubber grommets for quiet operation.

Thermal Expansion Valve (ZGB074 Models)

Assures optimal performance throughout the application range.

Removable element head.

Refrigerant Metering Orifice (All ZGA and ZGB036, 048, 060 Models)

Accurately meters refrigerant in system.

Refrigerant control is accomplished by exact sizing of refrigerant metering orifice.

Compressor Crankcase Heater

Protects against refrigerant migration that can occur during low ambient operation.

High Pressure Switch

Protects the compressor from overload conditions such as dirty condenser coils, blocked refrigerant flow, or loss of outdoor fan operation.

Automatic reset.

Filter/Drier

High capacity filter/drier protects the system from dirt and moisture.

5 Eco-last™ Coil System

Condenser coil features lightweight, all aluminum brazed fin construction.

Constructed of three

components: a flat extrusion tube, fins in-between the flat extrusion tube and two refrigerant manifolds.

Eco-last™ Coil System features:

- Improved heat transfer performance due to high primary surface area (flat tubes) versus secondary surface (fins).
- Smaller internal volume (reduced refrigerant charge).
- High durability (all aluminum construction).
- Fewer brazed joints.
- Compact design (reduces unit weight).
- Easy maintenance/cleaning.

Mounting brackets with rubber inserts secure coil to unit providing vibration dampening and corrosion protection.

Evaporator Coil

Copper tube construction, enhanced rippled-edge aluminum fins, flared shoulder tubing connections, silver soldered construction for improved heat transfer. Factory leak tested. Cross row circuiting with rifled tubing optimizes both sensible and latent cooling capacity.

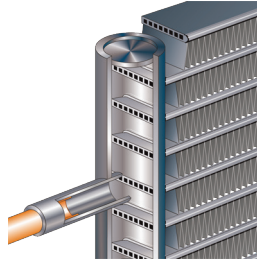

Condensate Drain Pan

Plastic pan, sloped to meet drainage requirements of the American Society of Heating Refrigeration and Air Conditioning Engineers 62.1.

End drain connection.

6 Outdoor Coil Fan Motor

Thermal overload protected, totally enclosed, permanently lubricated bearings, shaft down, fan guard mount.

Outdoor Coil Fan Guard

Polyvinyl chloride (PVC) coated fan guard furnished.

Required Selections

Cooling Capacity

Specify nominal cooling capacity of the unit.

Options / Accessories

Field Installed

Condensate Drain Trap

Field installed only.

Available in copper or polyvinyl chloride (PVC).

Drain Pan Overflow Switch

Monitors condensate level in drain pan, shuts down unit if drain becomes clogged.

Low Ambient Kit

Cycles the outdoor fan while allowing compressor operation in the cooling cycle. This intermittent fan operation allows the system to operate without icing the evaporator coil and losing capacity. Designed for use in ambient temperatures no lower than -18°C. A crankcase heater must be installed on the compressor.

FEATURES AND BENEFITS

CABINET

7 Construction

Heavy-gauge steel panels and full perimeter heavy-gauge galvanized steel base rail provides structural integrity for transportation, handling, and installation.

Base rails have rigging holes. Three sides of the base rail have fork slots.

Raised edges around duct and power entry openings in the bottom of the unit provide additional protection against water entering the building.

Airflow Choice

Units are shipped in downflow (vertical) configuration, can be field converted to horizontal airflow configuration without the need of a kit.

8 Power Entry

Electrical lines can be brought through the unit base or through horizontal access knock-outs.

Optional Bottom Power Entry Kit is available.

9 Exterior Panels

Constructed of heavy-gauge, galvanized steel with a two-layer enamel paint finish.

10 Insulation

All panels adjacent to conditioned air are fully insulated with non-hygroscopic fiberglass insulation.

Access Panels

Access panels are provided for the compressor, heating, controls, blower and air filter/economizer section.

Options / Accessories

Factory Installed

Corrosion Protection

A completely flexible immersed coating with an electro-deposited dry film process. (AST ElectroFin E-Coat) Meets Mil Spec MIL-P-53084, ASTM B117 Standard Method Salt Spray Testing.

Indoor Corrosion Protection:

- Coated coil

Outdoor Corrosion Protection:

- Coated coil

Field Installed

Combination Coil/Hail Guards

Heavy gauge steel frame painted to match cabinet with expanded metal mesh to protect the outdoor coil from damage.

CONTROLS

Unit Control

All control voltage is provided via a 24V (secondary) transformer with inline fuse protection.

Heat/Cool Staging

Capable of up to 2 heat / 2 cool staging with a thermostat.

Night Setback Mode

Saves energy by closing outdoor air dampers and operating supply fan on thermostat demand only.

Smoke Detectors

NOTE - Smoke detectors are not available and must be field provided by installer.

Options / Accessories

Field Installed

Thermostats

Control system and thermostat options, see page 39.

FEATURES AND BENEFITS

11 BLOWER

A wide selection of supply air blower options are available to meet a variety of air flow requirements.

Motor

Overload protected, equipped with ball bearings. Belt drive motors are offered on all models and are available in several different sizes to maximize air performance.

Two-speed belt drive motor (low static/high static) is available on 074 models.

Supply Air Blower

Forward curved blades, blower wheel is statically and dynamically balanced.

Equipped with ball bearings and adjustable pulley (allows speed change).

Required Selections

Supply Air Blower

Order blower motor kW and drive kit number required when base unit is ordered, see Drive Kit Specifications Table.

INDOOR AIR QUALITY

Air Filters

Disposable 51 mm filters furnished as standard.

Options / Accessories

Field Installed

Indoor Air Quality (CO₂) Sensor

Monitors CO₂ levels adjusts economizer dampers as needed for Demand Control Ventilation.

ELECTRICAL

Marked & Color-Coded Wiring

All electrical wiring is color-coded and marked to identify which components it is connecting.

Electrical Plugs

Positive connection electrical plugs are used to connect common accessories or maintenance parts for easy removal or installation.

Required Selections

Voltage Choice

Specify when ordering base unit.

ECONOMIZER OPTIONS

Factory or Field Installed

**Economizer (Downflow or Horizontal)
(Standard and High Performance Common Features)**

Outdoor Air Hood is furnished.

Economizer includes Barometric Relief Dampers with Exhaust Hood.

Barometric Relief Dampers allow relief of excess air, aluminum blade dampers prevent blow back and outdoor air infiltration during off cycle, bird screen furnished. Hood is furnished.

Single Sensible Temperature Control is furnished with the economizer

Outdoor air sensor enables Economizer if the outdoor temperature is less than the setpoint of the control.

Demand Control Ventilation (DCV) ready using optional CO₂ sensors.

NOTE - Horizontal Economizer is field installed only.

Standard Economizer Features

Gear-driven action, return air and outdoor air dampers, plug-in connections to unit, neoprene seals, 24-volt, fully-modulating spring return motor.

Standard Economizer Control Module

The Standard Economizer Control Module can be adjusted to operate based on outdoor air temperatures.



Economizer Controls:

- Damper Minimum Position - Can be set lower than traditional minimum air requirements resulting in cost savings.
- IAQ Sensor - Signals dampers to modulate and maintain 13°C when CO₂ is higher than the CO₂ setpoint.
- Demand Control Ventilation (DCV) LED - A steady green Demand Control Ventilation LED indicates the IAQ reading is higher than setpoint and requires more fresh air.
- Free Cool LED - A steady green LED indicates outdoor air is suitable for free cooling.

Free Cooling runs when outdoor air temperature is lower than the set temperature on the economizer control.

NOTE: The Free Cooling default setting for outdoor air temperature sensor is 13°C.

High Performance Economizer Features

Gear-driven action, high torque 24-volt fully-modulating spring return damper motor, return air and outdoor air dampers, plug-in connections to unit, nylon bearings, enhanced neoprene blade edge seals and flexible stainless steel jamb seals to minimize air leakage.

High Performance Economizer Control Module

Module provides inputs and outputs to control economizer based on parameter settings.



Module automatically detects sensors by polling to determine which sensors are installed in system.

Module displays any alarm messages (fault detection and diagnostics) as an aid in troubleshooting.

Non-volatile memory retains parameter settings in case of power failure.

Keypad with four navigation buttons and LCD screen is furnished for setting economizer parameters.

- Menu Up/Exit (⬆) button returns to the main menu.
- Arrow Up (▲) button moves to the previous or next parameter within the selected menu.
- Arrow Down (▼) button moves to the next parameter within the selected menu.
- Select (enter) (↵) button confirms parameter selection.

Main Menu Structure:

- STATUS (economizer and system operation status)
- SETPOINTS (settings for various setpoint parameters)
- SYSTEM SETUP (settings/information about the system)
- ADVANCED SETUP (freeze protection, CO₂ settings, stage 3 delay and additional calibration settings)
- CHECKOUT (damper positions)
- ALARMS (output signal that can be configured for remote alarm monitoring)

Refer to Installation Instructions for complete setup information and menu parameters available.

OPTIONS / ACCESSORIES

ECONOMIZER OPTIONS

(continued)

Field Installed

Single Enthalpy Temperature Control

Outdoor air enthalpy sensor enables Economizer if the outdoor enthalpy is less than the setpoint of the control.

EXHAUST OPTIONS

Field Installed

Power Exhaust Fan - Downflow or Horizontal

Installs external to unit for applications with Economizer option. Provides exhaust air pressure relief. Interlocked to run when supply air blower is operating, fan runs when outdoor air dampers are 50% open (adjustable), motor is overload protected.

Fan is 305 mm diameter with 5 fan blades. 0.25 kW motor.

OUTDOOR AIR OPTIONS

Field Installed

Outdoor Air Dampers - Downflow

Single blade damper, 0 to 25% (fixed) outdoor air adjustable, installs in unit.

Automatic model features fully modulating spring return damper motor with plug-in connection.

Manual model features a slide damper. Maximum mixed air temperature in cooling mode: 38°C.

Outdoor Air Hood is furnished.

ROOF CURBS

Hybrid Roof Curbs, Downflow

Nailer strip furnished, mates to unit, US National Roofing Contractors Approved, shipped knocked down.

Roof curb can be assembled using interlocking tabs to fasten corners together. No tools required.

Curb can also be fastened together with furnished hardware.

Available in 203, 356, 457, and 610 mm heights.

Adaptor Curbs (not shown)

Curbs are regionally sourced. Dimensions will vary based upon the source. Contact your local sales representative for a detailed cut sheet with applicable dimensions.

CEILING DIFFUSERS

Ceiling Diffusers (Flush and Step-Down)

Diffuser face and grilles with white powder coat finish, insulated (UL listed duct liner), diffuser box with collars for duct connection, fixed blades (flush diffusers) and double deflection blades (step-down diffusers), provisions for suspending, internally sealed (prevents recirculation), removable return air grille, adapts to T-bar ceiling grids or plaster ceilings.

Transitions (Supply and Return)

NOTE - Ceiling Diffuser Transitions are not furnished and must be field fabricated.

OPTIONS / ACCESSORIES

Item	Catalog No.	ZGA ZGB 036	ZGA ZGB 048	ZGA ZGB 060	ZGA 072	ZCB 074
COOLING SYSTEM						
Condensate Drain Trap	Polyvinyl Chloride (PVC) - C1TRAP20AD2	76W26	X	X	X	X
	Copper - C1TRAP10AD2	76W27	X	X	X	X
Drain Pan Overflow Switch	Z1SNSR90A1	99W59	X	X	X	X
Low Ambient Kit	Z1SNSR33A-1	99W67	X	X	X	X
HEATING SYSTEM						
Gas Heat Input	Standard 1 Stage - 16.7 kW input	Factory	O	O	O	O
	Medium 1 Stage - 27 kW input	Factory	O	O	O	O
	Medium 2 Stage - 20.8/27 kW input	Factory	O	O	O	O
	High 1 Stage - 38.7 kW input	Factory		O	O	O
	High 2 Stage - 29.0/38.7 kW input	Factory		O	O	O
Propane Conversion Kits	For 1 Stage models - Z1PROP10A-1	14N20	X	X	X	X
	For 2 Stage models - Z1PROP20A-1	14N21	X	X	X	X
Vertical Vent Extension Kit	C1EXTN20FF1	31W62	X	X	X	X
BLOWER - SUPPLY AIR						
Motors	Belt Drive - 0.62 kW Standard Efficiency	Factory	O	O		O
	Belt Drive - 0.93 kW Standard Efficiency	Factory	O	O	O	O
	Belt Drive - 1.24 kW Standard Efficiency	Factory			O	O
	Belt Drive - 1.24 kW (2 Speed)	Factory				O
Drive Kits See Blower Data Tables for selection	Kit #ZA07 - 705-1077 rev/min	Factory	O			
	Kit #ZA08 - 759-1158 rev/min	Factory		O		
	Kit #ZA09 - 919-1247 rev/min	Factory			O	
	Kit #ZA10 - 1025-1391 rev/min	Factory	O			
	¹ Kit #ZA11 - 1111-1437 rev/min	Factory		O		
	² Kit #ZA12 - 1190-1540 rev/min	Factory			O	
	Kit #ZAA03 - 665-921 rev/min	Factory				O
Kit #ZAA04 - 768-1023 rev/min	Factory				O	
Kit #ZAA05 - 921-1177 rev/min	Factory				O	
CABINET						
Combination	ZGA/ZGB036, ZGA/ZGB048, ZGA060 models - Z1GARD52A-1	12X19	X	X	X	
Coil/Hail Guards	ZGA072, ZGB060, ZGB074 models - Z1GARD52AT1	12X20			X	X
Corrosion Protection		Factory	O	O	O	O
ELECTRICAL						
Voltage 50 hz with neutral	380/420V - 3 phase	Factory	O	O	O	O
Bottom Power Entry Kit	Z1PEKT01A-1	98W08	X	X	X	X
ECONOMIZERS						
Standard Economizer With Outdoor Air Hood						
Standard Economizer (Downflow) Includes Barometric Exhaust Dampers and Exhaust Hood	Z1ECON30A-2	14D94	OX	OX	OX	OX
Standard Economizer (Horizontal) Includes Barometric Exhaust Dampers and Exhaust Hood	Z1ECON16A-2	14D92	X	X	X	X
Standard Economizer Controls						
Single Enthalpy Control	C1SNSR64FF1	53W64	X	X	X	X
High Performance Economizer With Outdoor Air Hood						
High Performance Economizer (Downflow) Includes Barometric Exhaust Dampers and Exhaust Hood	Z1ECON32A-2	14D95	OX	OX	OX	OX
High Performance Economizer (Horizontal) Includes Barometric Exhaust Dampers and Exhaust Hood	Z1ECON33A-2	14D93	X	X	X	X
High Performance Economizer Controls						
Single Enthalpy Control	C1SNSR61FF1	11G21	X	X	X	X

¹ ZA11 drive kits require the 0.93 kW motor.

² ZA12 drive kit requires the 1.24 kW motor.

NOTE - The catalog and model numbers that appear here are for ordering field installed accessories only.

OX - Field Installed or Configure to Order (factory installed)

O - Configure to Order (Factory Installed)

X - Field Installed.

OPTIONS / ACCESSORIES

Item		Catalog No.	ZGA ZGB 036	ZGA ZGB 048	ZGA ZGB 060	ZGA 072	ZCB 074
OUTDOOR AIR							
Outdoor Air Dampers - Includes Outdoor Air Hood							
Motorized	Z1DAMP21A-2	15D19	X	X	X	X	X
Manual	Z1DAMP11A-2	15D20	X	X	X	X	X
POWER EXHAUST FAN							
Standard Static (Downflow)	380/420V-3ph - Z1PWRE10A-1G	23E01	X	X	X	X	X
Standard Static (Horizontal)	380/420V-3ph - Z1PWRE10A-1G	28E01	X	X	X	X	X
INDOOR AIR QUALITY							
Indoor Air Quality (CO₂) Sensors							
Sensor - Wall-mount, off-white plastic cover with LCD display	C0SNSR50AE1L	77N39	X	X	X	X	X
Sensor - Wall-mount, black plastic case, no display, rated for plenum mounting	C0SNSR53AE1L	87N54	X	X	X	X	X
CO ₂ Sensor Duct Mounting Kit - for downflow applications	C0MISC19AE1	85L43	X	X	X	X	X
Aspiration Box - for duct mounting non-plenum rated CO ₂ sensor (77N39)	C0MISC16AE1	90N43	X	X	X	X	X
ROOF CURBS							
Hybrid Roof Curbs, Downflow							
203 mm height	Z1CURB70A-1	11F76	X	X	X	X	X
356 mm height	Z1CURB71A-1	11F77	X	X	X	X	X
457 mm height	Z1CURB72A-1	11F78	X	X	X	X	X
610 mm height	Z1CURB73A-1	11F79	X	X	X	X	X
CEILING DIFFUSERS							
Step-Down - Order one	RTD9-65S	13K60	X	X	X		
	RTD11-95S	13K61				X	X
Flush - Order one	FD9-65S	13K55	X	X	X		
	FD11-95S	13K56				X	X

NOTE - Ceiling Diffuser Transitions are not furnished and must be field fabricated.

NOTE - The catalog and model numbers that appear here are for ordering field installed accessories only.

OX - Field Installed or Configure to Order (factory installed)

O - Configure to Order (Factory Installed)

X - Field Installed.

SPECIFICATIONS - ZGA

General Data		Nominal Size	10.5 kW (3 Ton)	14.0 kW (4 Ton)	17.5 kW (5 Ton)	21 kW (6 Ton)
		Model No.	ZGA036S4B	ZGA048S4B	ZGA060S4B	ZGA072S4B
		Efficiency Type	Standard	Standard	Standard	Standard
		Blower Type	Single Speed Drive Belt	Single Speed Drive Belt	Single Speed Drive Belt	Single Speed Drive Belt
Cooling Performance	Gross Cooling Capacity - kW (Btuh)		9.0 (30 800)	12.1 (42 100)	14.9 (50 800)	17.6 (60 100)
	Net Cooling Capacity - kW (Btuh)		¹ 8.6 (29 200)	¹ 11.5 (39 300)	¹ 14.3 (48 800)	² 17.1 (58 400)
	Rated Air Flow - L/s (cfm)		565 (1200)	730 (1550)	780 (1650)	955 (2025)
	³ Sound Rating Number (SRN) (dBA)		77	80	83	84
	Total Unit Power - kW		2.5	3.7	4.6	5.2
	SEER (Btuh/Watt)		13.00	13.00	13.00	---
	EER (Btuh/Watt)		11.50	10.60	10.70	11.20
		¹ IEER (Btuh/Watt)	---	---	---	12.00
Refrigerant		Type	R-410A	R-410A	R-410A	R-410A
		Charge Furnished	1.8 kg (4 lbs. 1 oz.)	2.0 kg (4 lbs. 6 oz.)	2.4 kg (5 lbs. 6 oz.)	3.2 (7 lbs. 0 oz.)
Gas Heating Options - See page 13			Standard (1 Stage) or Medium (1 or 2 Stage)	Standard (1 Stage), Medium (1 or 2 Stage) or High (1 or 2 Stage)		
Compressor Type (one per unit)			Scroll	Scroll	Scroll	Scroll
Outdoor Coil	Net face area - m ² (sq. ft.)		1.19 (12.8)	1.19 (12.8)	1.41 (15.2)	1.85 (19.9)
	Number of rows		1	1	1	1
	Fins per m (in.)		906 (23)	906 (23)	906 (23)	906 (23)
Outdoor Coil Fan	Motor W (HP)		(1) 124 (1/6)	(1) 187 (1/4)	(1) 249 (1/3)	(1) 249 (1/3)
	Motor rev/min		688	688	896	900
	Total motor watts		160	210	275	290
	Diameter - mm (in.)		(1) 559 (22)	(1) 559 (22)	(1) 559 (22)	(1) 559 (22)
	Number of blades		4	4	3	3
	Total air volume - L/s (cfm)		1060 (2250)	1300 (2750)	1595 (3165)	1680 (3560)
Indoor Coil	Net face area - m ² (sq. ft.)		0.78 (8.4)	0.78 (8.4)	0.78 (8.4)	1.0 (10.8)
	Tube diameter - mm (in.)		9.5 (3/8)	9.5 (3/8)	9.5 (3/8)	9.5 (3/8)
	Number of rows		2	2	3	3
	Fins per m (in.)		551 (14)	551 (14)	551 (14)	551 (14)
	Drain Connection (no. and size) - in.		(1) 1 NPT	(1) 1 NPT	(1) 1 NPT	(1) 1 NPT
	Expansion device type		Fixed Orifice	Fixed Orifice	Fixed Orifice	Fixed Orifice
⁴ Indoor Blower & Drive Selection	Nominal Motor Size kW (hp)		0.62 (0.83), 0.93 (1.25)	0.62 (0.83), 0.93 (1.25)	0.93 (1.25), 1.24 (1.66)	0.93 (1.25), 1.24 (1.66)
	Maximum Usable Motor Size kW (hp)		0.71 (0.95), 1.07 (1.43)	0.71 (0.95), 1.07 (1.43)	1.07 (1.43), 1.42 (1.91)	1.07 (1.43), 1.42 (1.91)
	Available Drive Kits		ZA07 705-1077 rev/min ZA10 1025-1391 rev/min	ZA08 759-1158 rev/min ⁵ ZA11 1111-1437 rev/min	ZA09 919-1247 rev/min ⁶ ZA12 1190-1540 rev/min	ZAA03 665-921 rev/min ZAA04 768-1023 rev/min ZAA05 921-1177 rev/min
	Wheel nominal diameter x width - mm (in.)		254 x 254 (10 x 10)	254 x 254 (10 x 10)	254 x 254 (10 x 10)	381 x 229 (15 x 9)
Filters	Type		Disposable			
	Number and size - mm (in.)		(4) 356 x 508 x 51 (14 x 20 x 2)			(2) 406 x 508 x 51 (16 x 20 x 2) (2) 508 x 508 x 51 (20 x 20 x 2)
Electrical Characteristics - 50 Hz			380/420V - 50 hertz - 3 phase with neutral			

NOTE - Net capacity includes evaporator blower motor heat deduction. Gross capacity does not include evaporator blower motor heat deduction.

^{1,2} Rating test conditions are those included in Air-Conditioning, Heating and Refrigeration Institute (AHRI) Standard ¹ 210/240; or ² 340/360; 35°C (95°F) outdoor air temperature and 27°C (80°F) db/19°C (67°F) wb entering evaporator air; minimum external duct static pressure while operating at rated voltage and air volumes.

³ Sound Rating Number (SRN) rated in accordance with test conditions included in ANSI/AHRI Standard 270-2008.

⁴ Using total air volume and system static pressure requirements determine from blower performance tables rev/min and motor size required. Maximum usable size of motors furnished is shown. If motors of comparable size are used, be sure to keep within the service factor limitations outlined on the motor nameplate.

0.62 kW = 0.83 hp (1.0 nominal hp) while operating at rated voltage and frequency.

0.93 kW = 1.25 hp (1.5 nominal hp) while operating at rated voltage and frequency.

1.24 kW = 1.66 hp (2.0 nominal hp) while operating at rated voltage and frequency.

⁵ ZA11 drive kits require the 0.93 kW motor.

⁶ ZA12 drive kit requires the 1.24 kW motor.

SPECIFICATIONS - ZGB

General Data		Nominal Size	10.5 kW (3 Ton)	14.0 kW (4 Ton)	17.5 kW (5 Ton)	21.0 kW (6 Ton)
		Model No.	ZGB036S4B	ZGB048S4B	ZGB060S4B	ZGB074S4T
		Efficiency Type	Standard	Standard	Standard	Standard
		Blower Type	Single Speed Belt Drive	Single Speed Belt Drive	Single Speed Belt Drive	Two Speed Belt Drive
Cooling Performance	Gross Cooling Capacity - kW (Btuh)		9.2 (31 400)	12.0 (40 900)	14.6 (49 900)	17.3 (59 000)
	Net Cooling Capacity - kW (Btuh)		¹ 8.8 (30 200)	¹ 11.6 (39 700)	¹ 14.2 (48 600)	² 16.9 (57 500)
	Rated Air Flow - L/s (cfm)		560 (1190)	650 (1380)	815 (1725)	1038 (2200)
	³ Sound Rating Number (SRN) (dBA)		77	80	78	84
	Total Unit Power - kW		2.55	3.5	4.3	5.1
	¹ SEER (Btuh/Watt)		14.00	14.00	14.00	---
	² IEER (Btuh/Watt)		---	---	---	15.00
	EER (Btuh/Watt)		¹ 11.80	¹ 11.30	¹ 11.30	² 11.00
Refrigerant	Type		R-410A	R-410A	R-410A	R-410A
	Charge Furnished		2.32 kg (5 lbs. 2 oz.)	2.38 kg (5 lbs. 4 oz.)	3.32 kg (7 lbs. 5 oz.)	3.26 kg (7 lbs. 3 oz.)
Gas Heating Options - See page 13			Standard (1 Stage) or Medium (1 or 2 Stage)	Standard (1 Stage), Medium (1 or 2 Stage) or High (1 or 2 Stage)		
Compressor Type (one per unit)			Scroll	Scroll	Scroll	Scroll
Outdoor Coil	Net face area - m ² (sq. ft.)		1.41 (15.2)	1.41 (15.2)	1.85 (19.9)	1.85 (19.9)
	Number of rows		1	1	1	1
	Fins per m (in.)		906 (23)	906 (23)	906 (23)	906 (23)
Outdoor Coil Fan	Motor W (hp)		(1) 187 (1/4)	(1) 187 (1/4)	(1) 187 (1/4)	(1) 249 (1/3)
	Motor rev/min		690	690	690	900
	Total motor watts		260	260	260	290
	Diameter - mm (in.)		(1) 559 (22)	(1) 559 (22)	(1) 559 (22)	(1) 559 (22)
	Number of blades		4	4	4	3
	Total air volume - L/s (cfm)		1453 (3080)	1453 (3080)	1453 (3080)	1680 (3500)
Indoor Coil	Net face area - m ² (sq. ft.)		0.78 (8.4)	0.78 (8.4)	1.0 (10.8)	1.0 (10.8)
	Tube diameter - mm (in.)		9.5 (3/8)	9.5 (3/8)	9.5 (3/8)	9.5 (3/8)
	Number of rows		3	3	3	3
	Fins per m (in.)		551 (14)	551 (14)	551 (14)	551 (14)
	Drain Connection (no. and size) - in.		(1) 1 NPT	(1) 1 NPT	(1) 1 NPT	(1) 1 NPT
	Expansion device type		Fixed Orifice	Fixed Orifice	Fixed Orifice	Balance port TXV, removable head
⁴ Indoor Blower & Drive Selection	Nominal Motor Size kW (hp)		0.62 (0.83), 0.93 (1.25)	0.62 (0.83), 0.93 (1.25)	0.93 (1.25), 1.24 (1.66)	1.24 (1.66)
	Maximum Usable Motor Size kW (hp)		0.71 (0.95), 1.07 (1.43)	0.71 (0.95), 1.07 (1.43)	1.07 (1.43), 1.42 (1.91)	1.42 (1.91)
	Available Drive Kits		ZA07 705 - 1077 rev/min ZA10 1025 - 1391 rev/min	ZA08 759 - 1158 rev/min ⁵ ZA11 1111 - 1437 rev/min	ZA09 919-1247 rev/min ⁶ ZA12 1190-1540 rev/min	ZAA03 665-921 rev/min ZAA04 768-1023 rev/min ZAA05 921-1177 rev/min
	Wheel nominal diameter x width - mm (in.)		254 x 254 (10 x 10)	254 x 254 (10 x 10)	254 x 254 (10 x 10)	381 x 229 (15 x 9)
Filters	Type		Disposable			
	Number and size - mm (in.)		(4) 356 x 508 x 51 (14 x 20 x 2)		(2) 406 x 508 x 51 (16 x 20 x 2) (2) 508 x 508 x 51 (20 x 20 x 2)	(2) 508 x 508 x 51 (20 x 20 x 2) (2) 406 x 508 x 51 (16 x 20 x 2)
Electrical Characteristics - 50 Hz			380/420V - 50 hertz - 3 phase with neutral			

NOTE - Net capacity includes evaporator blower motor heat deduction. Gross capacity does not include evaporator blower motor heat deduction.

^{1,2} Rating test conditions are those included in Air-Conditioning, Heating and Refrigeration Institute (AHRI) Standard ¹210/240 or ²340/360; 35°C (95°F) outdoor air temperature and 27°C (80°F) db/19°C (67°F) wb entering evaporator air; minimum external duct static pressure while operating at rated voltage and air volumes.

³ Sound Rating Number (SRN) rated in accordance with test conditions included in ANSI/AHRI Standard 270-2008.

⁴ Using total air volume and system static pressure requirements determine from blower performance tables rev/min and motor size required. Maximum usable size of motors furnished is shown. If motors of comparable size are used, be sure to keep within the service factor limitations outlined on the motor nameplate.

0.62 kW = 0.83 hp (1.0 nominal hp) while operating at rated voltage and frequency.

0.93 kW = 1.25 hp (1.5 nominal hp) while operating at rated voltage and frequency.

1.24 kW = 1.66 hp (2.0 nominal hp) while operating at rated voltage and frequency.

⁵ ZA11 drive kits require the 0.93 kW motor.

⁶ ZA12 drive kit requires the 1.24 kW motor.

SPECIFICATIONS - GAS HEAT

Model No.		036, 048, 060	072, 074	036, 048, 060	072, 074	036, 048, 060	072, 074	048, 060	072, 074	048, 060	072, 074
Heat Input Type		Standard (1 Stage)		Medium (1 Stage)		Medium (2 Stage)		High (1 Stage)		High (2 Stage)	
Input Btuh	1st Stage	16.7 (57 000)		27.8 (95 000)		20.2 (71 000)		38.7 (132 000)		30.8 (99 000)	
	2nd Stage	---		---		27.8 (95 000)		---		38.7 (132 000)	
Output Btuh	1st Stage	13.5 (46 000)		22.3 (76 000)		17.3 (57 000)		31.1 (106 000)		25.1 (79 000)	
	2nd Stage	---		---		22.3 (76 000)		---		31.1 (106 000)	
Temperature Rise Range - °F	1st Stage	6-22°C (10-40°F)	3-19°C (5-35°F)	17-33°C (30-60°F)	8-25°C (15-45°F)	11-28°C (20-50°F)	3-19°C (5-35°F)	22-39°C (40-70°F)	17-33°C (30-60°F)	14-31°C (25-55°F)	11-28°C (20-50°F)
	2nd Stage	---	---	---	---	17-33°C (30-60°F)	8-25°C (15-45°F)	---	---	22-39°C (40-70°F)	17-33°C (30-60°F)
¹ Thermal Efficiency		80%	80%	80%	80%	80%	80%	80%	80%	80%	80%
Gas Supply Connections		1/2 in. NPT									
Recommended Gas Supply Pressure	Natural Gas	1.7 kPa (7.0 in. w.c.)									
	Propane	2.7 kPa (11.0 in. w.c.)									

¹ Thermal Efficiency at full input.

HIGH ALTITUDE DERATE

NOTE - Units may be installed at altitudes up to 610 m (2000 ft) above sea level without any modifications. At altitudes above 610 m (2000 ft.), units must be derated to match information in the table shown. At altitudes above 1372 m (4500 ft.), unit must be derated 2% for each 305 m (1000 ft.) above sea level. Example: 1524 m (5000 ft.) above sea level = 5 x 2% or 10% derate.

NOTE - This is the only permissible derate for these units.

Heat Input Type	Gas Manifold Pressure							
	Altitude		kPa		in. w.g.		Input Rate	
	meters	feet	Natural Gas	LPG/Propane	Natural Gas	LPG/Propane	kW	Btuh
Standard (1 stage)	610 - 1372	2001 - 4500	0.57	1.7	2.3	6.9	15.5	53 000
Medium (1 stage)	610 - 1372	2001 - 4500	0.57	1.7	2.3	6.9	25.8	88 000
Medium (2 stage)	610 - 1372	2001 - 4500	0.57 / 0.32	1.7 / 0.97	2.3 / 1.3	6.9 / 3.9	25.8 / 19.3	88 000 / 66 000
High (1 stage)	610 - 1372	2001 - 4500	0.57	1.7	2.3	6.9	35.8	122 000
High (2 stage)	610 - 1372	2001 - 4500	0.57 / 0.32	1.7 / 0.97	2.3 / 1.3	6.9 / 3.9	35.8 / 27.0	122 000 / 92 000

RATINGS - ZGA

NOTE - For Temperatures and Capacities not shown in tables, see bulletin - Cooling Unit Rating Table Correction Factor Data in Miscellaneous Engineering Data section.

10.5 kW - ZGA036S4

Entering Wet Bulb Temperature	Total Air Volume	Outdoor Air Temperature Entering Outdoor Coil																							
		26.7°C						35°C						43.3°C						51.7°C					
		Total Cool Cap.	Comp. Motor Input	Sensible To Total Ratio (S/T)			Total Cool Cap.	Comp. Motor Input	Sensible To Total Ratio (S/T)			Total Cool Cap.	Comp. Motor Input	Sensible To Total Ratio (S/T)			Total Cool Cap.	Comp. Motor Input	Sensible To Total Ratio (S/T)						
				Dry Bulb					Dry Bulb					Dry Bulb					Dry Bulb						
L/s	kW	kW	24°C	27°C	29°C	kW	kW	24°C	27°C	29°C	kW	kW	24°C	27°C	29°C	kW	kW	24°C	27°C	29°C					
17.2°C	455	8.9	1.63	0.73	0.89	1.00	7.9	2.00	0.73	0.91	1.00	6.4	2.39	0.74	0.95	1.00	4.6	2.87	0.80	1.00	1.00				
	565	9.6	1.64	0.79	0.96	1.00	8.4	2.00	0.80	0.99	1.00	7.0	2.40	0.83	1.00	1.00	5.1	2.88	0.93	1.00	1.00				
	680	10.1	1.65	0.85	1.00	1.00	9.0	2.01	0.86	1.00	1.00	7.5	2.41	0.90	1.00	1.00	5.5	2.88	1.00	1.00	1.00				
19.4°C	455	9.6	1.64	0.56	0.71	0.86	8.5	2.00	0.54	0.71	0.87	7.0	2.40	0.52	0.73	0.92	4.9	2.89	0.49	0.79	1.00				
	565	10.2	1.65	0.60	0.77	0.94	9.0	2.01	0.59	0.78	0.96	7.4	2.41	0.58	0.81	1.00	5.3	2.88	0.58	0.91	1.00				
	680	10.6	1.65	0.64	0.83	0.99	9.4	2.02	0.63	0.84	1.00	7.8	2.41	0.63	0.89	1.00	5.5	2.88	0.65	1.00	1.00				
21.7°C	455	10.2	1.65	0.41	0.56	0.70	9.1	2.01	0.37	0.54	0.69	7.5	2.41	0.32	0.52	0.71	5.4	2.89	0.24	0.51	0.77				
	565	10.8	1.66	0.43	0.60	0.76	9.6	2.02	0.40	0.59	0.76	8.0	2.41	0.36	0.58	0.80	5.7	2.89	0.29	0.60	0.89				
	680	11.3	1.66	0.45	0.64	0.81	10.1	2.03	0.43	0.63	0.83	8.3	2.42	0.39	0.64	1.00	5.9	2.89	0.33	0.67	0.99				

Entering Wet Bulb Temperature	Total Air Volume	Outdoor Air Temperature Entering Outdoor Coil																			
		46°C						48°C						50°C							
		Total Cool Cap.	Comp. Motor Input	Sensible To Total Ratio (S/T)			Total Cool Cap.	Comp. Motor Input	Sensible To Total Ratio (S/T)			Total Cool Cap.	Comp. Motor Input	Sensible To Total Ratio (S/T)							
				Dry Bulb					Dry Bulb					Dry Bulb							
L/s	kW	kW	24°C	27°C	29°C	kW	kW	24°C	27°C	29°C	kW	kW	24°C	27°C	29°C	kW	kW	24°C	27°C	29°C	
17.2°C	455	7.1	2.52	.75	.98	1.00	5.4	2.61	0.77	1.00	1.00	4.9	2.71	0.79	1.00	1.00	5.4	2.72	0.90	1.00	1.00
	565	7.6	2.53	.84	1.00	1.00	5.9	2.63	0.87	1.00	1.00	5.4	2.72	0.90	1.00	1.00	5.4	2.72	0.90	1.00	1.00
	680	8.0	2.54	.92	1.00	1.00	6.4	2.63	0.96	1.00	1.00	5.8	2.73	0.99	1.00	1.00	5.8	2.73	0.99	1.00	1.00
19.4°C	455	7.5	2.52	.50	.73	.95	5.8	2.62	0.50	0.76	0.98	5.2	2.72	0.50	0.78	1.00	5.2	2.72	0.50	0.78	1.00
	565	7.8	2.53	.57	.83	1.00	6.2	2.63	0.58	0.86	1.00	5.6	2.73	0.58	0.89	1.00	5.6	2.73	0.58	0.89	1.00
	680	8.0	2.54	.63	.91	1.00	6.5	2.64	0.64	0.94	1.00	5.9	2.73	0.65	0.98	1.00	5.9	2.73	0.65	0.98	1.00
21.7°C	455	7.9	2.53	.30	.52	.72	6.3	2.63	0.28	0.52	0.74	5.7	2.73	0.26	0.52	0.76	5.7	2.73	0.26	0.52	0.76
	565	8.3	2.54	.34	.58	.81	6.7	2.64	0.33	0.59	0.84	6.0	2.73	0.30	0.60	0.87	6.0	2.73	0.30	0.60	0.87
	680	8.5	2.55	.37	.64	.90	6.9	2.65	0.36	0.65	0.93	6.3	2.74	0.35	0.67	0.96	6.3	2.74	0.35	0.67	0.96

14.0 kW - ZGA048S4

Entering Wet Bulb Temperature	Total Air Volume	Outdoor Air Temperature Entering Outdoor Coil																							
		26.7°C						35°C						43.3°C						51.7°C					
		Total Cool Cap.	Comp. Motor Input	Sensible To Total Ratio (S/T)			Total Cool Cap.	Comp. Motor Input	Sensible To Total Ratio (S/T)			Total Cool Cap.	Comp. Motor Input	Sensible To Total Ratio (S/T)			Total Cool Cap.	Comp. Motor Input	Sensible To Total Ratio (S/T)						
				Dry Bulb					Dry Bulb					Dry Bulb					Dry Bulb						
L/s	kW	kW	24°C	27°C	29°C	kW	kW	24°C	27°C	29°C	kW	kW	24°C	27°C	29°C	kW	kW	24°C	27°C	29°C					
17.2°C	604	12.4	2.41	0.74	0.89	1.00	10.9	2.87	0.75	0.92	1.00	9.3	3.47	0.77	0.96	1.00	7.1	4.20	0.87	1.00	1.00				
	755	13.2	2.40	0.80	0.96	1.00	11.6	2.88	0.82	0.99	1.00	10.0	3.48	0.85	1.00	1.00	7.4	4.21	0.99	1.00	1.00				
	906	13.7	2.41	0.85	1.00	1.00	12.3	2.88	0.88	1.00	1.00	10.6	3.49	0.92	1.00	1.00	7.6	4.23	1.00	1.00	1.00				
19.4°C	604	13.2	2.40	0.57	0.72	0.86	11.7	2.88	0.56	0.73	0.89	10.1	3.49	0.56	0.75	0.93	7.1	4.21	0.57	0.85	1.00				
	755	14.1	2.40	0.61	0.78	0.93	12.5	2.89	0.61	0.80	0.96	10.6	3.49	0.61	0.83	1.00	7.4	4.23	0.66	0.98	1.00				
	906	14.7	2.41	0.65	0.83	0.99	13.0	2.89	0.65	0.86	1.00	11.0	3.50	0.66	0.91	1.00	7.7	4.24	0.74	1.00	1.00				
21.7°C	604	14.1	2.41	0.43	0.57	0.70	12.5	2.88	0.40	0.56	0.71	10.7	3.49	0.37	0.56	0.73	7.6	4.23	0.32	0.59	0.84				
	755	14.9	2.41	0.45	0.61	0.76	13.3	2.88	0.42	0.61	0.78	11.3	3.50	0.40	0.61	0.82	7.9	4.24	0.37	0.67	0.97				
	906	15.6	2.41	0.46	0.64	0.81	13.8	2.89	0.44	0.65	0.84	11.7	3.51	0.43	0.67	0.89	8.2	4.25	0.41	0.76	1.00				

Entering Wet Bulb Temperature	Total Air Volume	Outdoor Air Temperature Entering Outdoor Coil																			
		46°C						48°C						50°C							
		Total Cool Cap.	Comp. Motor Input	Sensible To Total Ratio (S/T)			Total Cool Cap.	Comp. Motor Input	Sensible To Total Ratio (S/T)			Total Cool Cap.	Comp. Motor Input	Sensible To Total Ratio (S/T)							
				Dry Bulb					Dry Bulb					Dry Bulb							
L/s	kW	kW	24°C	27°C	29°C	kW	kW	24°C	27°C	29°C	kW	kW	24°C	27°C	29°C	kW	kW	24°C	27°C	29°C	
17.2°C	604	7.9	3.88	0.80	1.00	1.00	7.9	3.88	0.80	1.00	1.00	7.3	4.08	0.83	1.00	1.00	7.3	4.08	0.83	1.00	1.00
	755	8.6	3.90	0.90	1.00	1.00	8.6	3.90	0.90	1.00	1.00	7.9	4.10	0.93	1.00	1.00	7.9	4.10	0.93	1.00	1.00
	906	9.2	3.91	0.98	1.00	1.00	9.2	3.91	0.98	1.00	1.00	8.4	4.10	1.00	1.00	1.00	8.4	4.10	1.00	1.00	1.00
19.4°C	604	8.6	3.90	0.56	0.79	0.98	8.6	3.90	0.56	0.79	0.98	7.8	4.09	0.56	0.81	1.00	7.8	4.09	0.56	0.81	1.00
	755	9.0	3.90	0.63	0.88	1.00	9.0	3.90	0.63	0.88	1.00	8.2	4.10	0.64	0.92	1.00	8.2	4.10	0.64	0.92	1.00
	906	9.3	3.91	0.69	0.97	1.00	9.3	3.91	0.69	0.97	1.00	8.4	4.11	0.71	1.00	1.00	8.4	4.11	0.71	1.00	1.00
21.7°C	604	9.2	3.91	0.35	0.56	0.77	9.2	3.91	0.35	0.56	0.77	8.4	4.10	0.33	0.57	0.80	8.4	4.10	0.33	0.57	0.80
	755	9.6	3.92	0.38	0.64	0.87	9.6	3.92	0.38	0.64	0.87	8.8	4.11	0.38	0.65	0.90	8.8	4.11	0.38	0.65	0.90
	906	9.9	3.92	0.42	0.70	0.95	9.9	3.92	0.42	0.70	0.95	9.1	4.12	0.41	0.73	0.99	9.1	4.12	0.41	0.73	0.99

RATINGS - ZGA

NOTE – For Temperatures and Capacities not shown in tables, see bulletin – Cooling Unit Rating Table Correction Factor Data in Miscellaneous Engineering Data section.

17.5 KW - ZGA060S4

Entering Wet Bulb Temperature	Total Air Volume	Outdoor Air Temperature Entering Outdoor Coil																			
		26.7°C						35°C					43.3°C					51.7°C			
		Total Cool Cap.	Comp. Motor Input	Sensible To Total Ratio (S/T)			Total Cool Cap.	Comp. Motor Input	Sensible To Total Ratio (S/T)			Total Cool Cap.	Comp. Motor Input	Sensible To Total Ratio (S/T)			Total Cool Cap.	Comp. Motor Input	Sensible To Total Ratio (S/T)		
				Dry Bulb					Dry Bulb					Dry Bulb					Dry Bulb		
L/s	kW	kW	24°C	27°C	29°C	kW	kW	24°C	27°C	29°C	kW	kW	24°C	27°C	29°C	kW	kW	24°C	27°C	29°C	
17.2°C	755	15.0	2.87	0.76	0.92	1.00	13.3	3.42	0.79	0.96	1.00	11.6	4.10	0.82	1.00	1.00	9.7	4.99	0.90	1.00	1.00
	944	15.7	2.89	0.83	1.00	1.00	14.2	3.45	0.86	1.00	1.00	12.5	4.15	0.92	1.00	1.00	10.4	5.04	1.00	1.00	1.00
	1133	16.6	2.91	0.89	1.00	1.00	15.0	3.47	0.94	1.00	1.00	13.1	4.18	1.00	1.00	1.00	10.9	5.08	1.00	1.00	1.00
19.4°C	755	16.0	2.9	0.59	0.74	0.89	14.3	3.45	0.59	0.76	0.93	12.4	4.14	0.61	0.80	0.99	10.1	5.02	0.63	0.88	1.00
	944	16.8	2.92	0.63	0.81	0.98	15.0	3.47	0.64	0.84	1.00	12.9	4.17	0.66	0.90	1.00	10.4	5.05	0.71	0.99	1.00
	1133	17.3	2.93	0.67	0.87	1.00	15.4	3.49	0.69	0.91	1.00	13.3	4.18	0.72	0.98	1.00	10.9	5.07	0.78	1.00	1.00
21.7°C	755	17.0	2.93	0.43	0.58	0.72	15.2	3.48	0.43	0.59	0.74	13.2	4.18	0.42	0.60	0.78	10.8	5.07	0.41	0.63	0.86
	944	17.8	2.95	0.45	0.62	0.78	15.9	3.51	0.45	0.64	0.82	13.8	4.21	0.44	0.66	0.87	11.3	5.10	0.44	0.71	0.97
	1133	18.4	2.96	0.47	0.66	0.85	16.4	3.53	0.47	0.68	0.89	14.2	4.23	0.47	0.72	0.96	11.5	5.13	0.48	0.78	1.00

Entering Wet Bulb Temperature	Total Air Volume	Outdoor Air Temperature Entering Outdoor Coil														
		46°C					48°C					50°C				
		Total Cool Cap.	Comp. Motor Input	Sensible To Total Ratio (S/T)			Total Cool Cap.	Comp. Motor Input	Sensible To Total Ratio (S/T)			Total Cool Cap.	Comp. Motor Input	Sensible To Total Ratio (S/T)		
				Dry Bulb					Dry Bulb					Dry Bulb		
L/s	kW	kW	24°C	27°C	29°C	kW	kW	24°C	27°C	29°C	kW	kW	24°C	27°C	29°C	
17.2°C	755	11.0	4.36	0.84	1.00	1.00	10.6	4.57	0.86	1.00	1.00	10.1	4.79	0.88	1.00	1.00
	944	11.9	4.40	0.94	1.00	1.00	11.4	4.62	0.96	1.00	1.00	10.8	4.84	0.99	1.00	1.00
	1133	12.5	4.43	1.00	1.00	1.00	11.9	4.65	1.00	1.00	1.00	11.4	4.87	1.00	1.00	1.00
19.4°C	755	11.7	4.40	0.61	.82	1.00	11.2	4.60	0.62	0.84	1.00	10.6	4.82	0.63	0.86	1.00
	944	12.2	4.42	0.68	.92	1.00	11.6	4.63	0.69	0.94	1.00	11.0	4.85	0.70	0.97	1.00
	1133	12.5	4.44	0.73	1.00	1.00	12.0	4.65	0.75	1.00	1.00	11.4	4.87	0.76	1.00	1.00
21.7°C	755	12.5	4.44	0.41	.61	.80	11.9	4.65	0.41	0.62	0.82	11.4	4.88	0.41	0.63	0.84
	944	13.0	4.46	0.44	.67	.90	12.4	4.68	0.44	0.68	0.92	11.8	4.90	0.44	0.70	0.95
	1133	13.4	4.49	0.47	.73	.98	12.7	4.70	0.47	0.75	1.00	12.1	4.92	0.47	0.77	1.00

22 KW - ZGA072S4

Entering Wet Bulb Temperature	Total Air Volume	Outdoor Air Temperature Entering Outdoor Coil																			
		26.7°C						35°C					43.3°C					51.7°C			
		Total Cool Cap.	Comp. Motor Input	Sensible To Total Ratio (S/T)			Total Cool Cap.	Comp. Motor Input	Sensible To Total Ratio (S/T)			Total Cool Cap.	Comp. Motor Input	Sensible To Total Ratio (S/T)			Total Cool Cap.	Comp. Motor Input	Sensible To Total Ratio (S/T)		
				Dry Bulb					Dry Bulb					Dry Bulb					Dry Bulb		
L/s	kW	kW	24°C	27°C	29°C	kW	kW	24°C	27°C	29°C	kW	kW	24°C	27°C	29°C	kW	kW	24°C	27°C	29°C	
17.2°C	945	18.0	3.57	0.79	0.94	1.00	15.8	4.23	0.80	0.97	1.00	13.3	5.01	0.83	1.00	1.00	10.8	6.01	0.89	1.00	1.00
	1135	18.8	3.60	0.84	0.99	1.00	16.6	4.26	0.86	1.00	1.00	14.3	5.06	0.9	1.00	1.00	11.6	6.05	0.96	1.00	1.00
	1320	19.7	3.63	0.89	1.00	1.00	17.5	4.30	0.91	1.00	1.00	15	5.10	0.96	1.00	1.00	12.2	6.08	1.00	1.00	1.00
19.4°C	945	19.3	3.62	0.61	0.77	0.91	16.9	4.28	0.60	0.79	0.94	14.3	5.06	0.59	0.81	0.98	11.4	6.04	0.60	0.87	1.00
	1135	20.0	3.64	0.64	0.82	0.97	17.6	4.31	0.64	0.85	1.00	14.9	5.09	0.65	0.88	1.00	11.8	6.07	0.67	0.95	1.00
	1320	20.7	3.67	0.66	0.87	1.00	18.1	4.33	0.67	0.90	1.00	15.4	5.12	0.69	0.94	1.00	12.2	6.08	0.72	1.00	1.00
21.7°C	945	20.5	3.66	0.44	0.60	0.75	18.1	4.33	0.42	0.60	0.76	15.4	5.12	0.39	0.60	0.79	12.3	6.09	0.34	0.61	0.85
	1135	21.3	3.69	0.46	0.64	0.80	18.8	4.36	0.44	0.64	0.83	15.9	5.15	0.42	0.65	0.87	12.8	6.12	0.39	0.67	0.93
	1320	21.9	3.72	0.47	0.67	0.85	19.2	4.38	0.45	0.67	0.88	16.4	5.18	0.44	0.70	0.93	13.1	6.15	0.41	0.73	0.99

Entering Wet Bulb Temperature	Total Air Volume	Outdoor Air Temperature Entering Outdoor Coil														
		46°C					48°C					50°C				
		Total Cool Cap.	Comp. Motor Input	Sensible To Total Ratio (S/T)			Total Cool Cap.	Comp. Motor Input	Sensible To Total Ratio (S/T)			Total Cool Cap.	Comp. Motor Input	Sensible To Total Ratio (S/T)		
				Dry Bulb					Dry Bulb					Dry Bulb		
L/s	kW	kW	24°C	27°C	29°C	kW	kW	24°C	27°C	29°C	kW	kW	24°C	27°C	29°C	
17.2°C	945	12.6	5.30	0.82	1.00	1.00	11.4	5.78	0.87	1.00	1.00	11.4	5.78	0.87	1.00	1.00
	1135	13.5	5.34	0.90	1.00	1.00	12.2	5.83	0.95	1.00	1.00	12.2	5.83	0.95	1.00	1.00
	1320	14.2	5.39	0.97	1.00	1.00	12.8	5.86	1.00	1.00	1.00	12.8	5.86	1.00	1.00	1.00
19.4°C	945	13.5	5.35	0.58	0.80	0.99	12.0	5.82	0.59	0.85	1.00	12.0	5.82	0.59	0.85	1.00
	1135	14.0	5.38	0.63	0.88	1.00	12.5	5.85	0.66	0.93	1.00	12.5	5.85	0.66	0.93	1.00
	1320	14.4	5.40	0.68	0.95	1.00	13.0	5.87	0.71	0.99	1.00	13.0	5.87	0.71	0.99	1.00
21.7°C	945	14.4	5.40	0.37	0.58	0.78	12.9	5.87	0.36	0.60	0.84	12.9	5.87	0.36	0.60	0.84
	1135	15.0	5.42	0.40	0.63	0.86	13.5	5.90	0.39	0.67	0.92	13.5	5.90	0.39	0.67	0.92
	1320	15.4	5.46	0.42	0.69	0.93	13.8	5.93	0.42	0.73	0.98	13.8	5.93	0.42	0.73	0.98

RATINGS - ZGB

NOTE – For Temperatures and Capacities not shown in tables, see bulletin – Cooling Unit Rating Table Correction Factor Data in Miscellaneous Engineering Data section.

10.5 KW - ZGB036S4

Entering Wet Bulb Temperature	Total Air Volume	Outdoor Air Temperature Entering Outdoor Coil																							
		26.7°C						35°C						43.3°C						51.7°C					
		Total Cool Cap.	Comp. Motor Input	Sensible To Total Ratio (S/T)			Total Cool Cap.	Comp. Motor Input	Sensible To Total Ratio (S/T)			Total Cool Cap.	Comp. Motor Input	Sensible To Total Ratio (S/T)			Total Cool Cap.	Comp. Motor Input	Sensible To Total Ratio (S/T)						
				Dry Bulb					Dry Bulb					Dry Bulb					Dry Bulb						
L/s	kW	kW	24°C	27°C	29°C	kW	kW	24°C	27°C	29°C	kW	kW	24°C	27°C	29°C	kW	kW	24°C	27°C	29°C					
17.2°C	455	9.1	1.62	0.73	0.89	1.00	8.30	1.92	0.75	0.94	1.00	7.40	2.29	0.79	0.99	1.00	7.70	2.77	1.00	1.00	1.00				
	565	9.6	1.62	0.79	0.99	1.00	8.80	1.93	0.82	1.00	1.00	7.90	2.30	0.88	1.00	1.00	7.70	2.77	1.00	1.00	1.00				
	680	10.0	1.63	0.86	1.00	1.00	9.20	1.94	0.91	1.00	1.00	8.30	2.31	0.97	1.00	1.00	7.70	2.77	1.00	1.00	1.00				
19.4°C	455	9.6	1.63	0.57	0.71	0.85	8.80	1.93	0.58	0.73	0.90	7.90	2.30	0.60	0.77	0.96	7.70	2.77	1.00	1.00	1.00				
	565	10.1	1.63	0.61	0.77	0.95	9.20	1.94	0.62	0.80	1.00	8.10	2.31	0.65	0.86	1.00	7.70	2.77	1.00	1.00	1.00				
	680	10.4	1.64	0.65	0.83	1.00	9.50	1.94	0.67	0.88	1.00	8.40	2.31	0.69	0.95	1.00	7.70	2.77	1.00	1.00	1.00				
21.7°C	455	10.2	1.64	0.43	0.56	0.69	9.30	1.94	0.43	0.57	0.71	8.30	2.31	0.43	0.59	0.74	7.70	2.77	1.00	1.00	1.00				
	565	10.7	1.65	0.44	0.60	0.75	9.70	1.95	0.45	0.62	0.78	8.60	2.31	0.45	0.64	0.83	7.70	2.77	1.00	1.00	1.00				
	680	11.0	1.66	0.46	0.64	0.81	10.00	1.95	0.46	0.66	0.86	8.90	2.32	0.48	0.69	1.00	7.70	2.77	1.00	1.00	1.00				

Entering Wet Bulb Temperature	Total Air Volume	Outdoor Air Temperature Entering Outdoor Coil														
		46°C					48°C					50°C				
		Total Cool Cap.	Comp. Motor Input	Sensible To Total Ratio (S/T)			Total Cool Cap.	Comp. Motor Input	Sensible To Total Ratio (S/T)			Total Cool Cap.	Comp. Motor Input	Sensible To Total Ratio (S/T)		
				Dry Bulb					Dry Bulb					Dry Bulb		
L/s	kW	kW	24°C	27°C	29°C	kW	kW	24°C	27°C	29°C	kW	kW	24°C	27°C	29°C	
17.2°C	455	7.1	2.43	.84	1.00	1.00	6.9	2.54	.82	1.00	1.00	6.7	2.65	.84	1.00	1.00
	565	7.6	2.44	.92	1.00	1.00	7.3	2.55	.93	1.00	1.00	7.1	2.66	.95	1.00	1.00
	680	8.0	2.45	.99	1.00	1.00	7.7	2.55	1.00	1.00	1.00	7.4	2.67	1.00	1.00	1.00
19.4°C	455	7.5	2.44	.62	.81	.98	7.2	2.54	.62	.80	1.00	6.9	2.66	.62	.81	1.00
	565	7.8	2.45	.68	.90	1.00	7.5	2.55	.67	.90	1.00	7.2	2.66	.68	.92	1.00
	680	8.0	2.45	.73	.98	1.00	7.7	2.55	.72	.99	1.00	7.4	2.67	.73	1.00	1.00
21.7°C	455	7.9	2.45	.43	.61	.78	7.7	2.55	.43	.61	.78	7.4	2.66	.43	.62	.79
	565	8.3	2.45	.46	.67	.87	8.0	2.56	.45	.66	.87	7.6	2.67	.46	.68	.90
	680	8.5	2.46	.48	.73	.96	8.1	2.56	.48	.72	.97	7.8	2.67	.49	.73	.99

14.0 KW - ZGB048S4

Entering Wet Bulb Temperature	Total Air Volume	Outdoor Air Temperature Entering Outdoor Coil																							
		26.7°C						35°C						43.3°C						51.7°C					
		Total Cool Cap.	Comp. Motor Input	Sensible To Total Ratio (S/T)			Total Cool Cap.	Comp. Motor Input	Sensible To Total Ratio (S/T)			Total Cool Cap.	Comp. Motor Input	Sensible To Total Ratio (S/T)			Total Cool Cap.	Comp. Motor Input	Sensible To Total Ratio (S/T)						
				Dry Bulb					Dry Bulb					Dry Bulb					Dry Bulb						
L/s	kW	kW	24°C	27°C	29°C	kW	kW	24°C	27°C	29°C	kW	kW	24°C	27°C	29°C	kW	kW	24°C	27°C	29°C					
17.2°C	604	11.7	2.29	0.75	0.90	1.00	11.10	2.74	0.78	0.95	1.00	10.60	3.30	0.82	1.00	1.00	10.10	4.05	0.88	1.00	1.00				
	755	12.1	2.30	0.79	0.99	1.00	11.60	2.75	0.84	1.00	1.00	11.10	3.33	0.90	1.00	1.00	10.40	4.08	0.97	1.00	1.00				
	906	12.5	2.32	0.86	1.00	1.00	12.00	2.77	0.92	1.00	1.00	11.40	3.35	0.98	1.00	1.00	10.70	4.11	1.00	1.00	1.00				
19.4°C	604	12.2	2.30	0.59	0.72	0.86	11.60	2.76	0.62	0.76	0.91	11.00	3.33	0.65	0.79	0.97	10.30	4.07	0.69	0.85	1.00				
	755	12.6	2.32	0.62	0.78	0.96	12.00	2.77	0.65	0.81	1.00	11.30	3.34	0.69	0.87	1.00	10.60	4.09	0.74	0.95	1.00				
	906	12.9	2.33	0.66	0.84	1.00	12.20	2.79	0.69	0.89	1.00	11.50	3.36	0.73	0.96	1.00	10.70	4.11	0.78	1.00	1.00				
21.7°C	604	12.7	2.32	0.45	0.57	0.70	12.10	2.78	0.47	0.60	0.73	11.40	3.35	0.50	0.64	0.77	10.70	4.10	0.54	0.68	0.83				
	755	13.2	2.34	0.46	0.61	0.75	12.50	2.80	0.49	0.64	0.79	11.80	3.38	0.52	0.68	0.85	10.90	4.13	0.55	0.73	0.93				
	906	13.5	2.36	0.47	0.65	0.81	12.80	2.81	0.50	0.69	0.87	12.00	3.39	0.53	0.72	0.93	11.00	4.14	0.57	0.77	1.00				

Entering Wet Bulb Temperature	Total Air Volume	Outdoor Air Temperature Entering Outdoor Coil														
		46°C					48°C					50°C				
		Total Cool Cap.	Comp. Motor Input	Sensible To Total Ratio (S/T)			Total Cool Cap.	Comp. Motor Input	Sensible To Total Ratio (S/T)			Total Cool Cap.	Comp. Motor Input	Sensible To Total Ratio (S/T)		
				Dry Bulb					Dry Bulb					Dry Bulb		
L/s	kW	kW	24°C	27°C	29°C	kW	kW	24°C	27°C	29°C	kW	kW	24°C	27°C	29°C	
17.2°C	604	8.6	3.69	.77	.98	1.00	10.3	3.69	.84	1.00	1.00	10.2	3.87	.86	1.00	1.00
	755	9.3	3.71	.86	1.00	1.00	10.7	3.72	.93	1.00	1.00	10.6	3.91	.95	1.00	1.00
	906	9.8	3.72	.94	1.00	1.00	11.0	3.75	1.00	1.00	1.00	10.9	3.94	1.00	1.00	1.00
19.4°C	604	9.3	3.71	.55	.75	.95	10.6	3.71	.67	.82	1.00	10.5	3.90	.69	.84	1.00
	755	9.8	3.72	.61	.84	1.00	10.9	3.73	.71	.91	1.00	10.7	3.92	.73	.93	1.00
	906	10.1	3.72	.66	.93	1.00	11.1	3.75	.76	.99	1.00	10.9	3.93	.77	1.00	1.00
21.7°C	604	9.9	3.73	.36	.55	.74	11.0	3.75	.52	.66	.80	10.8	3.93	.53	.67	.81
	755	10.4	3.73	.39	.61	.83	11.3	3.77	.53	.70	.89	11.1	3.96	.54	.72	.91
	906	10.8	3.73	.42	.67	.91	11.5	3.78	.55	.75	.98	11.3	3.97	.56	.76	.99

RATINGS - ZGB

NOTE – For Temperatures and Capacities not shown in tables, see bulletin – Cooling Unit Rating Table Correction Factor Data in Miscellaneous Engineering Data section.

17.5 KW - ZGB060S4

Entering Wet Bulb Temperature	Total Air Volume	Outdoor Air Temperature Entering Outdoor Coil																				
		26.7°C						35°C					43.3°C					51.7°C				
		Total Cool Cap.	Comp. Motor Input	Sensible To Total Ratio (S/T)			Total Cool Cap.	Comp. Motor Input	Sensible To Total Ratio (S/T)			Total Cool Cap.	Comp. Motor Input	Sensible To Total Ratio (S/T)			Total Cool Cap.	Comp. Motor Input	Sensible To Total Ratio (S/T)			
				Dry Bulb					Dry Bulb					Dry Bulb					Dry Bulb			
		L/s	kW	kW	24°C	27°C	29°C	kW	kW	24°C	27°C	29°C	kW	kW	24°C	27°C	29°C	kW	kW	24°C	27°C	29°C
17.2°C	755	14.7	2.88	0.78	0.93	1.00	12.7	3.43	0.79	0.96	1.00	10.7	4.12	0.81	0.99	1.00	8.7	5.03	0.86	1.00	1.00	
	945	15.5	2.89	0.86	0.99	1.00	13.7	3.44	0.87	1.00	1.00	11.8	4.16	0.9	1.00	1.00	9.6	5.09	0.96	1.00	1.00	
	1135	16.5	2.91	0.91	1.00	1.00	14.7	3.47	0.94	1.00	1.00	12.6	4.19	0.97	1.00	1.00	10.3	5.13	1.00	1.00	1.00	
19.4°C	755	15.9	2.9	0.6	0.76	0.91	13.9	3.45	0.59	0.77	0.93	11.7	4.16	0.57	0.79	0.97	9.3	5.07	0.56	0.84	1.00	
	945	16.7	2.91	0.64	0.83	0.97	14.6	3.46	0.64	0.86	1.00	12.4	4.18	0.64	0.89	1.00	9.8	5.10	0.65	0.94	1.00	
	1135	17.4	2.92	0.69	0.89	1.00	15.1	3.47	0.69	0.92	1.00	12.9	4.20	0.71	0.96	1.00	10.3	5.13	0.73	1.00	1.00	
21.7°C	755	17.0	2.91	0.43	0.59	0.74	15.0	3.48	0.41	0.58	0.75	12.7	4.19	0.36	0.57	0.77	10.2	5.12	0.32	0.57	0.81	
	945	17.9	2.93	0.45	0.64	0.81	15.8	3.49	0.43	0.63	0.83	13.5	4.22	0.4	0.65	0.87	10.8	5.16	0.36	0.66	0.92	
	1135	18.6	2.95	0.48	0.69	0.88	16.3	3.51	0.46	0.69	0.90	13.9	4.25	0.44	0.71	0.94	11.2	5.19	0.41	0.75	1.00	

Entering Wet Bulb Temperature	Total Air Volume	Outdoor Air Temperature Entering Outdoor Coil														
		46°C					48°C					50°C				
		Total Cool Cap.	Comp. Motor Input	Sensible To Total Ratio (S/T)			Total Cool Cap.	Comp. Motor Input	Sensible To Total Ratio (S/T)			Total Cool Cap.	Comp. Motor Input	Sensible To Total Ratio (S/T)		
				Dry Bulb					Dry Bulb					Dry Bulb		
		L/s	kW	kW	24°C	27°C	29°C	kW	kW	24°C	27°C	29°C	kW	kW	24°C	27°C
17.2°C	755	11.0	4.36	0.84	1.00	1.00	9.6	4.59	.83	1.00	1.00	9.1	4.82	.85	1.00	1.00
	945	11.9	4.40	0.94	1.00	1.00	10.6	4.64	.93	1.00	1.00	10.1	4.88	.94	1.00	1.00
	1135	12.5	4.43	1.00	1.00	1.00	11.3	4.68	1.00	1.00	1.00	10.8	4.91	1.00	1.00	1.00
19.4°C	755	11.7	4.40	0.61	.82	1.00	10.4	4.63	.57	.81	.99	9.8	4.86	.57	.82	1.00
	945	12.2	4.42	0.68	.92	1.00	11.0	4.66	.64	.92	1.00	10.4	4.89	.65	.93	1.00
	1135	12.5	4.44	0.73	1.00	1.00	11.4	4.69	.72	.99	1.00	10.8	4.92	.73	1.00	1.00
21.7°C	755	12.5	4.44	0.41	.61	.80	11.4	4.68	.33	.57	.79	10.8	4.91	.32	.57	.80
	945	13.0	4.46	0.44	.67	.90	12.0	4.71	.38	.65	.90	11.3	4.94	.37	.65	.91
	1135	13.4	4.49	0.47	.73	.98	12.4	4.74	.42	.73	.97	11.8	4.98	.41	.73	.98

RATINGS - ZGB

NOTE – For Temperatures and Capacities not shown in tables, see bulletin – Cooling Unit Rating Table Correction Factor Data in Miscellaneous Engineering Data section.

21 KW - ZGB074S4 - COOLING CAPACITY (1ST STAGE)

Entering Wet Bulb Temperature	Total Air Volume	Outdoor Air Temperature Entering Outdoor Coil																							
		18.1°C						24°C						29°C						35°C					
		Total Cool Cap.	Comp. Motor Input	Sensible To Total Ratio (S/T)			Total Cool Cap.	Comp. Motor Input	Sensible To Total Ratio (S/T)			Total Cool Cap.	Comp. Motor Input	Sensible To Total Ratio (S/T)			Total Cool Cap.	Comp. Motor Input	Sensible To Total Ratio (S/T)						
				Dry Bulb					Dry Bulb					Dry Bulb					Dry Bulb						
L/s	kW	kW	24°C	27°C	29°C	kW	kW	24°C	27°C	29°C	kW	kW	24°C	27°C	29°C	kW	kW	24°C	27°C	29°C					
17.2°C	565	13.0	1.85	0.74	0.88	0.98	12.1	2.13	0.74	0.90	1.00	11.3	2.39	0.75	0.92	1.00	10.3	2.76	0.76	0.95	1.00				
	755	14.1	1.84	0.81	0.99	1.00	13.2	2.12	0.82	1.00	1.00	12.4	2.39	0.83	1.00	1.00	11.5	2.76	0.86	1.00	1.00				
	945	15.2	1.83	0.88	1.00	1.00	14.3	2.11	0.90	1.00	1.00	13.5	2.39	0.93	1.00	1.00	12.5	2.75	0.95	1.00	1.00				
19.4°C	565	13.9	1.84	0.59	0.73	0.83	13.0	2.12	0.59	0.74	0.84	12.2	2.39	0.59	0.75	0.86	11.1	2.76	0.59	0.76	0.88				
	755	15.1	1.83	0.65	0.82	0.93	14.0	2.12	0.65	0.83	0.95	13.1	2.39	0.65	0.84	0.97	12.0	2.76	0.66	0.87	1.00				
	945	15.8	1.83	0.70	0.89	1.00	14.7	2.11	0.70	0.91	1.00	13.8	2.38	0.71	0.93	1.00	12.6	2.75	0.72	0.97	1.00				
21.7°C	565	15.2	1.83	0.41	0.54	0.63	14.3	2.12	0.40	0.54	0.63	13.5	2.39	0.39	0.54	0.63	12.3	2.75	0.37	0.53	0.64				
	755	16.5	1.82	0.42	0.59	0.69	15.4	2.11	0.42	0.59	0.70	14.5	2.38	0.41	0.59	0.71	13.3	2.75	0.39	0.59	0.72				
	945	17.3	1.81	0.45	0.63	0.74	16.2	2.10	0.44	0.64	0.76	15.2	2.37	0.43	0.64	0.78	13.9	2.74	0.42	0.65	0.80				

21 KW - ZGB074S4 - COOLING CAPACITY (2ND STAGE)

Entering Wet Bulb Temperature	Total Air Volume	Outdoor Air Temperature Entering Outdoor Coil																							
		26.7°C						35°C						43.3°C						51.7°C					
		Total Cool Cap.	Comp. Motor Input	Sensible To Total Ratio (S/T)			Total Cool Cap.	Comp. Motor Input	Sensible To Total Ratio (S/T)			Total Cool Cap.	Comp. Motor Input	Sensible To Total Ratio (S/T)			Total Cool Cap.	Comp. Motor Input	Sensible To Total Ratio (S/T)						
				Dry Bulb					Dry Bulb					Dry Bulb					Dry Bulb						
L/s	kW	kW	24°C	27°C	29°C	kW	kW	24°C	27°C	29°C	kW	kW	24°C	27°C	29°C	kW	kW	24°C	27°C	29°C					
17.2°C	905	16.9	3.26	0.79	0.97	1.00	15.1	3.90	0.82	1.00	1.00	13.5	4.69	0.85	1.00	1.00	11.6	5.68	0.91	1.00	1.00				
	1135	18.0	3.29	0.86	1.00	1.00	16.3	3.95	0.90	1.00	1.00	14.5	4.74	0.95	1.00	1.00	12.5	5.72	1.00	1.00	1.00				
	1360	18.9	3.33	0.94	1.00	1.00	17.2	3.98	0.97	1.00	1.00	15.3	4.77	1.00	1.00	1.00	13.2	5.75	1.00	1.00	1.00				
19.4°C	905	17.9	3.29	0.63	0.80	0.91	16.1	3.94	0.63	0.83	0.95	14.1	4.72	0.65	0.86	1.00	11.8	5.69	0.67	0.93	1.00				
	1135	18.7	3.32	0.68	0.88	1.00	16.8	3.97	0.69	0.91	1.00	14.7	4.75	0.71	0.96	1.00	12.5	5.72	0.75	1.00	1.00				
	1360	19.3	3.34	0.73	0.95	1.00	17.3	3.99	0.74	0.99	1.00	15.3	4.77	0.77	1.00	1.00	13.2	5.75	0.83	1.00	1.00				
21.7°C	905	19.4	3.35	0.41	0.57	0.67	17.5	4.00	0.40	0.58	0.69	15.5	4.78	0.38	0.58	0.71	13.2	5.75	0.37	0.60	0.75				
	1135	20.3	3.38	0.43	0.62	0.74	18.3	4.03	0.42	0.63	0.76	16.1	4.81	0.41	0.64	0.80	13.7	5.78	0.40	0.67	0.85				
	1360	21.0	3.41	0.44	0.66	0.80	18.9	4.06	0.44	0.68	0.83	16.6	4.84	0.43	0.70	0.88	14.1	5.81	0.43	0.74	0.94				

Entering Wet Bulb Temperature	Total Air Volume	Outdoor Air Temperature Entering Outdoor Coil																	
		46°C						48°C						50°C					
		Total Cool Cap.	Comp. Motor Input	Sensible To Total Ratio (S/T)			Total Cool Cap.	Comp. Motor Input	Sensible To Total Ratio (S/T)			Total Cool Cap.	Comp. Motor Input	Sensible To Total Ratio (S/T)					
				Dry Bulb					Dry Bulb					Dry Bulb					
L/s	kW	kW	24°C	27°C	29°C	kW	kW	24°C	27°C	29°C	kW	kW	24°C	27°C	29°C				
17.2°C	905	12.9	4.98	0.86	1.00	1.00	12.5	5.21	0.88	1.00	1.00	12.0	5.46	0.89	1.00	1.00			
	1135	13.9	5.03	0.97	1.00	1.00	13.4	5.25	0.98	1.00	1.00	12.9	5.50	1.00	1.00	1.00			
	1360	14.7	5.06	1.00	1.00	1.00	14.2	5.29	1.00	1.00	1.00	13.6	5.54	1.00	1.00	1.00			
19.4°C	905	13.4	5.00	0.65	0.88	1.00	12.9	5.23	0.66	0.89	1.00	12.3	5.47	0.66	0.91	1.00			
	1135	14.0	5.03	0.72	0.98	1.00	13.5	5.26	0.73	1.00	1.00	13.0	5.50	0.74	1.00	1.00			
	1360	14.7	5.06	0.79	1.00	1.00	14.2	5.29	0.80	1.00	1.00	13.6	5.53	0.81	1.00	1.00			
21.7°C	905	14.8	5.07	0.38	0.59	0.72	14.2	5.29	0.37	0.59	0.73	13.7	5.54	0.37	0.60	0.74			
	1135	15.4	5.10	0.40	0.65	0.81	14.9	5.32	0.40	0.66	0.82	14.2	5.57	0.40	0.67	0.84			
	1360	15.9	5.13	0.43	0.71	0.89	15.3	5.35	0.43	0.72	0.91	14.7	5.59	0.43	0.73	0.93			

BLOWER DATA - BELT DRIVE - ZGA036 - DOWNFLOW

BLOWER TABLE INCLUDES RESISTANCE FOR BASE UNIT ONLY WITH DRY INDOOR COIL AND AIR FILTERS IN PLACE.

FOR ALL UNITS ADD:

1 - Any factory installed options air resistance (heat section, economizer, wet coil, etc.).

2 - Any field installed accessories air resistance (duct resistance, diffuser, etc.).

See page 35 for blower motors and drives and wet coil and options/accessory air resistance data.

Air Volume		External Static - Pa (in.w.g.)																							
		25 (0.10)		50 (0.20)		75 (0.30)		100 (0.40)		125 (0.50)		150 (0.60)		175 (0.70)		200 (0.80)									
L/s	cfm	Rev/min	kW	BHP	Rev/min	kW	BHP	Rev/min	kW	BHP	Rev/min	kW	BHP	Rev/min	kW	BHP	Rev/min	kW	BHP						
425	900	566	0.12	0.16	631	0.13	0.18	699	0.14	0.19	768	0.16	0.21	836	0.16	0.22	901	0.19	0.25	961	0.20	0.27	1016	0.22	0.29
472	1000	591	0.13	0.18	656	0.15	0.20	724	0.16	0.21	793	0.17	0.23	859	0.19	0.25	922	0.20	0.27	979	0.22	0.30	1032	0.25	0.33
519	1100	618	0.15	0.20	684	0.16	0.22	752	0.18	0.24	819	0.19	0.26	883	0.21	0.28	944	0.23	0.31	998	0.25	0.34	1049	0.28	0.37
566	1200	648	0.17	0.23	715	0.19	0.25	782	0.20	0.27	847	0.22	0.29	910	0.24	0.32	967	0.26	0.35	1020	0.28	0.38	1068	0.31	0.42
613	1300	681	0.19	0.26	748	0.21	0.28	814	0.22	0.30	878	0.25	0.33	937	0.27	0.36	992	0.29	0.39	1043	0.32	0.43	1089	0.35	0.47
661	1400	718	0.22	0.29	783	0.24	0.32	848	0.25	0.34	909	0.28	0.37	966	0.31	0.41	1018	0.33	0.44	1067	0.36	0.48	1112	0.39	0.52
708	1500	757	0.25	0.33	821	0.27	0.36	883	0.29	0.39	941	0.31	0.42	995	0.34	0.46	1046	0.37	0.50	1092	0.40	0.54	1136	0.43	0.57

Air Volume		External Static - Pa (in.w.g.)																							
		225 (0.90)		250 (1.00)		275 (1.10)		300 (1.20)		325 (1.30)		350 (1.40)		375 (1.50)		400 (1.60)									
L/s	cfm	Rev/min	kW	BHP	Rev/min	kW	BHP	Rev/min	kW	BHP	Rev/min	kW	BHP	Rev/min	kW	BHP	Rev/min	kW	BHP						
425	900	1067	0.24	0.32	1115	0.26	0.35	1161	0.28	0.37	1205	0.30	0.40	1247	0.32	0.43	1287	0.35	0.47	1326	0.37	0.50	1365	0.40	0.53
472	1000	1081	0.27	0.36	1128	0.29	0.39	1173	0.31	0.41	1216	0.33	0.44	1258	0.36	0.48	1297	0.38	0.51	1336	0.40	0.54	1374	0.43	0.58
519	1100	1097	0.30	0.40	1143	0.32	0.43	1187	0.34	0.46	1229	0.37	0.49	1270	0.39	0.52	1309	0.42	0.56	1347	0.44	0.59	1384	0.47	0.63
566	1200	1115	0.34	0.45	1159	0.36	0.48	1202	0.38	0.51	1244	0.40	0.54	1284	0.43	0.58	1323	0.46	0.61	1360	0.48	0.65	1397	0.51	0.69
613	1300	1134	0.37	0.50	1177	0.40	0.53	1219	0.42	0.56	1260	0.45	0.60	1300	0.47	0.63	1338	0.50	0.67	1375	0.53	0.71	1411	0.56	0.75
661	1400	1155	0.41	0.55	1197	0.44	0.59	1238	0.46	0.62	1278	0.49	0.66	1317	0.52	0.70	1354	0.55	0.74	1391	0.58	0.78	1426	0.61	0.82
708	1500	1177	0.46	0.61	1218	0.48	0.65	1258	0.51	0.68	1298	0.54	0.72	1336	0.57	0.76	1373	0.60	0.81	1409	0.63	0.85	1443	0.66	0.89

BLOWER DATA - BELT DRIVE - ZGA036 - HORIZONTAL

BLOWER TABLE INCLUDES RESISTANCE FOR BASE UNIT ONLY WITH DRY INDOOR COIL AND AIR FILTERS IN PLACE.
FOR ALL UNITS ADD:

- 1 - Any factory installed options air resistance (heat section, economizer, wet coil, etc.).
- 2 - Any field installed accessories air resistance (duct resistance, diffuser, etc.).

See page 35 for blower motors and drives and wet coil and options/accessory air resistance data.

Air Volume		External Static - Pa (in.w.g.)																							
		25 (0.10)		50 (0.20)		75 (0.30)		100 (0.40)		125 (0.50)		150 (0.60)		175 (0.70)		200 (0.80)									
L/s	cfm	Rev/ min	kW	BHP	Rev/ min	kW	BHP	Rev/ min	kW	BHP	Rev/ min	kW	BHP	Rev/ min	kW	BHP	Rev/ min	kW	BHP						
425	900	566	0.10	0.13	634	0.12	0.16	704	0.13	0.18	773	0.15	0.20	839	0.17	0.23	902	0.19	0.25	961	0.21	0.28	1016	0.23	0.31
472	1000	590	0.12	0.16	658	0.13	0.18	728	0.15	0.20	795	0.17	0.23	860	0.19	0.25	920	0.21	0.28	977	0.23	0.31	1030	0.25	0.34
519	1100	615	0.13	0.18	685	0.15	0.20	754	0.17	0.23	820	0.19	0.26	883	0.22	0.29	941	0.24	0.32	995	0.26	0.35	1046	0.28	0.38
566	1200	644	0.16	0.21	714	0.17	0.23	782	0.19	0.26	847	0.22	0.29	908	0.25	0.33	963	0.27	0.36	1015	0.29	0.39	1064	0.31	0.42
613	1300	676	0.18	0.24	746	0.20	0.27	814	0.22	0.30	876	0.25	0.33	934	0.28	0.37	987	0.31	0.41	1037	0.33	0.44	1083	0.35	0.47
661	1400	713	0.21	0.28	782	0.23	0.31	847	0.26	0.35	907	0.28	0.38	962	0.31	0.42	1013	0.34	0.45	1060	0.37	0.49	1105	0.39	0.52
708	1500	755	0.25	0.33	821	0.27	0.36	883	0.29	0.39	939	0.32	0.43	991	0.35	0.47	1039	0.37	0.50	1085	0.40	0.54	1128	0.43	0.57

External Static - Pa (in.w.g.)

Air Volume		External Static - Pa (in.w.g.)																							
		225 (0.90)		250 (1.00)		275 (1.10)		300 (1.20)		325 (1.30)		350 (1.40)		375 (1.50)		400 (1.60)									
L/s	cfm	Rev/ min	kW	BHP	Rev/ min	kW	BHP	Rev/ min	kW	BHP	Rev/ min	kW	BHP	Rev/ min	kW	BHP	Rev/ min	kW	BHP						
425	900	1068	0.25	0.33	1118	0.27	0.36	1165	0.28	0.38	1211	0.31	0.41	1254	0.33	0.44	1294	0.35	0.47	1332	0.37	0.50	1369	0.40	0.54
472	1000	1080	0.28	0.37	1128	0.29	0.39	1175	0.31	0.42	1219	0.34	0.45	1262	0.36	0.48	1302	0.38	0.51	1340	0.41	0.55	1377	0.43	0.58
519	1100	1094	0.31	0.41	1141	0.32	0.43	1186	0.34	0.46	1230	0.37	0.49	1272	0.39	0.52	1311	0.42	0.56	1349	0.45	0.60	1386	0.48	0.64
566	1200	1110	0.34	0.45	1155	0.36	0.48	1200	0.38	0.51	1243	0.40	0.54	1284	0.43	0.58	1323	0.46	0.61	1361	0.49	0.66	1398	0.52	0.70
613	1300	1128	0.37	0.50	1172	0.40	0.53	1215	0.42	0.56	1258	0.44	0.59	1298	0.47	0.63	1337	0.50	0.67	1375	0.54	0.72	1411	0.57	0.76
661	1400	1148	0.41	0.55	1191	0.43	0.58	1233	0.46	0.62	1274	0.48	0.65	1314	0.51	0.69	1353	0.55	0.74	1391	0.59	0.79	1427	0.62	0.83
708	1500	1170	0.46	0.61	1211	0.48	0.64	1252	0.51	0.68	1293	0.54	0.72	1333	0.57	0.76	1371	0.60	0.81	1408	0.64	0.86	1444	0.68	0.91

BLOWER DATA - BELT DRIVE - ZGA048 - DOWNFLOW

BLOWER TABLE INCLUDES RESISTANCE FOR BASE UNIT ONLY WITH DRY INDOOR COIL AND AIR FILTERS IN PLACE.

FOR ALL UNITS ADD:

1 - Any factory installed options air resistance (heat section, economizer, wet coil, etc.).

2 - Any field installed accessories air resistance (duct resistance, diffuser, etc.).

See page 35 for blower motors and drives and wet coil and options/accessory air resistance data.

Air Volume		External Static - Pa (in.w.g.)																							
		25 (0.10)		50 (0.20)		75 (0.30)		100 (0.40)		125 (0.50)		150 (0.60)		175 (0.70)		200 (0.80)									
L/s	cfm	Rev/ min	kW	BHP	Rev/ min	kW	BHP	Rev/ min	kW	BHP	Rev/ min	kW	BHP	Rev/ min	kW	BHP	Rev/ min	kW	BHP						
566	1200	648	0.17	0.23	715	0.19	0.25	782	0.20	0.27	847	0.22	0.29	910	0.24	0.32	967	0.26	0.35	1020	0.28	0.38	1068	0.31	0.42
613	1300	681	0.19	0.26	748	0.21	0.28	814	0.22	0.30	878	0.25	0.33	937	0.27	0.36	992	0.29	0.39	1043	0.32	0.43	1089	0.35	0.47
661	1400	718	0.22	0.29	783	0.24	0.32	848	0.25	0.34	909	0.28	0.37	966	0.31	0.41	1018	0.33	0.44	1067	0.36	0.48	1112	0.39	0.52
708	1500	757	0.25	0.33	821	0.27	0.36	883	0.29	0.39	941	0.31	0.42	995	0.34	0.46	1046	0.37	0.50	1092	0.40	0.54	1136	0.43	0.57
755	1600	798	0.28	0.38	860	0.31	0.41	919	0.33	0.44	974	0.35	0.47	1026	0.38	0.51	1074	0.41	0.55	1119	0.44	0.59	1161	0.47	0.63
802	1700	840	0.32	0.43	899	0.34	0.46	955	0.37	0.49	1007	0.40	0.53	1057	0.43	0.57	1103	0.46	0.61	1146	0.49	0.66	1187	0.52	0.70
849	1800	882	0.36	0.48	938	0.38	0.51	991	0.41	0.55	1041	0.44	0.59	1088	0.47	0.63	1132	0.51	0.68	1174	0.54	0.72	1214	0.57	0.77
897	1900	924	0.40	0.54	977	0.43	0.58	1027	0.46	0.62	1075	0.49	0.66	1120	0.52	0.70	1163	0.56	0.75	1203	0.60	0.80	1242	0.63	0.85
944	2000	965	0.46	0.61	1016	0.48	0.65	1064	0.51	0.69	1110	0.55	0.74	1153	0.59	0.79	1194	0.63	0.84	1233	0.66	0.89	1271	0.71	0.95

Air Volume		External Static - Pa (in.w.g.)																							
		225 (0.90)		250 (1.00)		275 (1.10)		300 (1.20)		325 (1.30)		350 (1.40)		375 (1.50)		400 (1.60)									
L/s	cfm	Rev/ min	kW	BHP	Rev/ min	kW	BHP	Rev/ min	kW	BHP	Rev/ min	kW	BHP	Rev/ min	kW	BHP	Rev/ min	kW	BHP						
566	1200	1115	0.34	0.45	1159	0.36	0.48	1202	0.38	0.51	1244	0.40	0.54	1284	0.43	0.58	1323	0.46	0.61	1360	0.48	0.65	1397	0.51	0.69
613	1300	1134	0.37	0.50	1177	0.40	0.53	1219	0.42	0.56	1260	0.45	0.60	1300	0.47	0.63	1338	0.50	0.67	1375	0.53	0.71	1411	0.56	0.75
661	1400	1155	0.41	0.55	1197	0.44	0.59	1238	0.46	0.62	1278	0.49	0.66	1317	0.52	0.70	1354	0.55	0.74	1391	0.58	0.78	1426	0.61	0.82
708	1500	1177	0.46	0.61	1218	0.48	0.65	1258	0.51	0.68	1298	0.54	0.72	1336	0.57	0.76	1373	0.60	0.81	1409	0.63	0.85	1443	0.66	0.89
755	1600	1201	0.51	0.68	1241	0.53	0.71	1280	0.56	0.75	1319	0.60	0.80	1357	0.63	0.84	1393	0.66	0.88	1428	0.69	0.93	1462	0.72	0.97
802	1700	1226	0.55	0.74	1265	0.59	0.79	1304	0.62	0.83	1342	0.65	0.87	1378	0.69	0.92	1414	0.72	0.96	1448	0.75	1.01	1482	0.78	1.05
849	1800	1253	0.61	0.82	1291	0.65	0.87	1329	0.68	0.91	1366	0.72	0.96	1402	0.75	1.01	1436	0.78	1.05	1469	0.82	1.10	1502	0.85	1.14
897	1900	1280	0.67	0.90	1318	0.71	0.95	1355	0.75	1.00	1391	0.78	1.05	1426	0.82	1.10	1459	0.86	1.15	1492	0.90	1.20	1524	0.93	1.24
944	2000	1309	0.75	1.00	1346	0.78	1.05	1382	0.82	1.10	1417	0.87	1.16	1451	0.90	1.21	1484	0.93	1.25	1515	0.97	1.30	1547	1.01	1.35

BLOWER DATA - BELT DRIVE - ZGA048 - HORIZONTAL

BLOWER TABLE INCLUDES RESISTANCE FOR BASE UNIT ONLY WITH DRY INDOOR COIL AND AIR FILTERS IN PLACE.
FOR ALL UNITS ADD:

- 1 - Any factory installed options air resistance (heat section, economizer, wet coil, etc.).
- 2 - Any field installed accessories air resistance (duct resistance, diffuser, etc.).

See page 35 for blower motors and drives and wet coil and options/accessory air resistance data.

Air Volume		External Static - Pa (in.w.g.)																							
		25 (0.10)		50 (0.20)		75 (0.30)		100 (0.40)		125 (0.50)		150 (0.60)		175 (0.70)		200 (0.80)									
L/s	cfm	Rev/min	kW	BHP	Rev/min	kW	BHP	Rev/min	kW	BHP	Rev/min	kW	BHP	Rev/min	kW	BHP	Rev/min	kW	BHP						
566	1200	644	0.16	0.21	714	0.17	0.23	782	0.19	0.26	847	0.22	0.29	908	0.25	0.33	963	0.27	0.36	1015	0.29	0.39	1064	0.31	0.42
613	1300	676	0.18	0.24	746	0.20	0.27	814	0.22	0.30	876	0.25	0.33	934	0.28	0.37	987	0.31	0.41	1037	0.33	0.44	1083	0.35	0.47
661	1400	713	0.21	0.28	782	0.23	0.31	847	0.26	0.35	907	0.28	0.38	962	0.31	0.42	1013	0.34	0.45	1060	0.37	0.49	1105	0.39	0.52
708	1500	755	0.25	0.33	821	0.27	0.36	883	0.29	0.39	939	0.32	0.43	991	0.35	0.47	1039	0.37	0.50	1085	0.40	0.54	1128	0.43	0.57
755	1600	798	0.28	0.38	860	0.31	0.41	918	0.34	0.45	971	0.36	0.48	1020	0.39	0.52	1067	0.41	0.55	1110	0.44	0.59	1152	0.47	0.63
802	1700	842	0.32	0.43	900	0.35	0.47	954	0.37	0.50	1004	0.40	0.54	1051	0.43	0.57	1095	0.46	0.61	1137	0.48	0.65	1177	0.51	0.69
849	1800	885	0.37	0.49	940	0.40	0.53	990	0.42	0.56	1037	0.45	0.60	1081	0.47	0.63	1124	0.50	0.67	1164	0.54	0.72	1204	0.57	0.76
897	1900	928	0.42	0.56	979	0.44	0.59	1026	0.47	0.63	1070	0.50	0.67	1113	0.53	0.71	1153	0.56	0.75	1193	0.59	0.79	1231	0.63	0.84
944	2000	969	0.47	0.63	1017	0.50	0.67	1062	0.52	0.70	1104	0.55	0.74	1145	0.59	0.79	1184	0.62	0.83	1222	0.66	0.88	1259	0.70	0.94
Air Volume		External Static - Pa (in.w.g.)																							
		225 (0.90)		250 (1.00)		275 (1.10)		300 (1.20)		325 (1.30)		350 (1.40)		375 (1.50)		400 (1.60)									
L/s	cfm	Rev/min	kW	BHP	Rev/min	kW	BHP	Rev/min	kW	BHP	Rev/min	kW	BHP	Rev/min	kW	BHP	Rev/min	kW	BHP						
566	1200	1110	0.34	0.45	1155	0.36	0.48	1200	0.38	0.51	1243	0.40	0.54	1284	0.43	0.58	1323	0.46	0.61	1361	0.49	0.66	1398	0.52	0.70
613	1300	1128	0.37	0.50	1172	0.40	0.53	1215	0.42	0.56	1258	0.44	0.59	1298	0.47	0.63	1337	0.50	0.67	1375	0.54	0.72	1411	0.57	0.76
661	1400	1148	0.41	0.55	1191	0.43	0.58	1233	0.46	0.62	1274	0.48	0.65	1314	0.51	0.69	1353	0.55	0.74	1391	0.59	0.79	1427	0.62	0.83
708	1500	1170	0.46	0.61	1211	0.48	0.64	1252	0.51	0.68	1293	0.54	0.72	1333	0.57	0.76	1371	0.60	0.81	1408	0.64	0.86	1444	0.68	0.91
755	1600	1193	0.50	0.67	1233	0.53	0.71	1273	0.56	0.75	1313	0.59	0.79	1352	0.63	0.84	1390	0.66	0.89	1427	0.70	0.94	1463	0.75	1.00
802	1700	1217	0.54	0.73	1256	0.58	0.78	1296	0.61	0.82	1335	0.65	0.87	1374	0.69	0.93	1411	0.73	0.98	1447	0.77	1.03	1482	0.81	1.09
849	1800	1242	0.60	0.81	1281	0.64	0.86	1320	0.68	0.91	1359	0.72	0.96	1396	0.76	1.02	1433	0.80	1.07	1468	0.84	1.13	1503	0.88	1.18
897	1900	1269	0.67	0.90	1307	0.71	0.95	1346	0.75	1.01	1383	0.79	1.06	1420	0.84	1.12	1456	0.88	1.18	1491	0.92	1.23	1525	0.96	1.29
944	2000	1297	0.74	0.99	1334	0.78	1.05	1372	0.83	1.11	1409	0.87	1.17	1445	0.92	1.23	1480	0.96	1.29	1514	1.00	1.34	1547	1.04	1.40

BLOWER DATA - BELT DRIVE - ZGA060 - DOWNFLOW

BLOWER TABLE INCLUDES RESISTANCE FOR BASE UNIT ONLY WITH DRY INDOOR COIL AND AIR FILTERS IN PLACE.

FOR ALL UNITS ADD:

1 - Any factory installed options air resistance (heat section, economizer, wet coil, etc.).

2 - Any field installed accessories air resistance (duct resistance, diffuser, etc.).

See page 35 for blower motors and drives and wet coil and options/accessory air resistance data.

Air Volume		External Static - Pa (in.w.g.)																							
		25 (0.10)		50 (0.20)		75 (0.30)		100 (0.40)		125 (0.50)		150 (0.60)		175 (0.70)		200 (0.80)									
L/s	cfm	Rev/min	BHP	Rev/min	BHP	Rev/min	BHP	Rev/min	BHP	Rev/min	BHP	Rev/min	BHP	Rev/min	BHP	Rev/min	BHP								
755	1600	817	0.29	0.39	877	0.31	0.42	935	0.34	0.45	989	0.36	0.48	1040	0.39	0.52	1087	0.42	0.56	1131	0.45	0.60	1173	0.48	0.65
802	1700	859	0.33	0.44	917	0.35	0.47	972	0.37	0.50	1023	0.40	0.54	1071	0.43	0.58	1117	0.46	0.62	1159	0.50	0.67	1199	0.53	0.71
849	1800	902	0.37	0.49	957	0.40	0.53	1008	0.42	0.56	1057	0.45	0.60	1103	0.48	0.64	1147	0.51	0.69	1188	0.55	0.74	1227	0.59	0.79
897	1900	944	0.42	0.56	996	0.44	0.59	1045	0.47	0.63	1092	0.51	0.68	1136	0.54	0.72	1178	0.57	0.77	1218	0.61	0.82	1257	0.65	0.87
944	2000	986	0.47	0.63	1035	0.50	0.67	1083	0.53	0.71	1127	0.57	0.76	1170	0.60	0.81	1210	0.64	0.86	1249	0.68	0.91	1287	0.72	0.97
991	2100	1027	0.53	0.71	1075	0.56	0.75	1120	0.60	0.80	1163	0.63	0.85	1204	0.67	0.90	1243	0.72	0.96	1281	0.76	1.02	1318	0.80	1.07
1038	2200	1069	0.60	0.80	1115	0.63	0.84	1158	0.67	0.90	1200	0.71	0.95	1239	0.75	1.01	1277	0.80	1.07	1314	0.84	1.13	1350	0.89	1.19
1085	2300	1111	0.67	0.90	1155	0.71	0.95	1197	0.75	1.01	1237	0.80	1.07	1275	0.84	1.13	1312	0.89	1.19	1348	0.93	1.25	1383	0.98	1.31
1133	2400	1154	0.75	1.01	1196	0.80	1.07	1236	0.84	1.13	1274	0.89	1.19	1311	0.93	1.25	1347	0.98	1.32	1382	1.03	1.38	1417	1.08	1.45

External Static - Pa (in.w.g.)

Air Volume		External Static - Pa (in.w.g.)																							
		225 (0.90)		250 (1.00)		275 (1.10)		300 (1.20)		325 (1.30)		350 (1.40)		375 (1.50)		400 (1.60)									
L/s	cfm	Rev/min	BHP	Rev/min	BHP	Rev/min	BHP	Rev/min	BHP	Rev/min	BHP	Rev/min	BHP	Rev/min	BHP	Rev/min	BHP								
755	1600	1213	0.51	0.69	1252	0.54	0.73	1292	0.57	0.77	1330	0.60	0.81	1367	0.63	0.85	1403	0.66	0.89	1438	0.70	0.94	1472	0.73	0.98
802	1700	1239	0.57	0.76	1278	0.60	0.80	1316	0.63	0.84	1354	0.66	0.89	1390	0.69	0.93	1425	0.73	0.98	1459	0.76	1.02	1492	0.80	1.07
849	1800	1266	0.62	0.83	1304	0.66	0.88	1342	0.69	0.93	1378	0.73	0.98	1414	0.76	1.02	1448	0.80	1.07	1481	0.84	1.12	1514	0.87	1.16
897	1900	1294	0.69	0.92	1332	0.72	0.97	1369	0.76	1.02	1404	0.80	1.07	1439	0.84	1.12	1472	0.87	1.17	1504	0.90	1.21	1536	0.94	1.26
944	2000	1324	0.76	1.02	1360	0.80	1.07	1396	0.84	1.13	1431	0.88	1.18	1465	0.92	1.23	1497	0.95	1.27	1529	0.98	1.32	1560	1.02	1.37
991	2100	1354	0.84	1.13	1390	0.88	1.18	1425	0.93	1.24	1459	0.96	1.29	1491	1.00	1.34	1523	1.04	1.39	1554	1.07	1.43	1585	1.10	1.48
1038	2200	1385	0.93	1.25	1420	0.97	1.30	1454	1.01	1.36	1487	1.05	1.41	1519	1.09	1.46	1550	1.13	1.51	1581	1.16	1.55	1611	1.19	1.60
1085	2300	1418	1.02	1.37	1452	1.07	1.43	1485	1.10	1.48	1517	1.14	1.53	1548	1.18	1.58	1578	1.22	1.63	1608	1.25	1.68	1639	1.28	1.72
1133	2400	1451	1.13	1.51	1484	1.16	1.56	1516	1.21	1.62	1547	1.25	1.67	1578	1.28	1.72	1607	1.31	1.76	1637	1.35	1.81	1667	1.38	1.85

BLOWER DATA - BELT DRIVE - ZGA060 - HORIZONTAL

BLOWER TABLE INCLUDES RESISTANCE FOR BASE UNIT ONLY WITH DRY INDOOR COIL AND AIR FILTERS IN PLACE.

FOR ALL UNITS ADD:

1 - Any factory installed options air resistance (heat section, economizer, wet coil, etc.).

2 - Any field installed accessories air resistance (duct resistance, diffuser, etc.).

See page 35 for blower motors and drives and wet coil and options/accessory air resistance data.

Air Volume		External Static - Pa (in.w.g.)																							
		25 (0.10)		50 (0.20)		75 (0.30)		100 (0.40)		125 (0.50)		150 (0.60)		175 (0.70)		200 (0.80)									
L/s	cfm	Rev/ min	BHP	kW	Rev/ min	BHP	kW	Rev/ min	BHP	kW	Rev/ min	BHP	kW	Rev/ min	BHP	kW	Rev/ min	BHP	kW						
755	1600	817	0.29	0.39	878	0.31	0.42	934	0.34	0.46	985	0.37	0.49	1034	0.40	0.53	1080	0.42	0.56	1123	0.45	0.60	1164	0.48	0.64
802	1700	861	0.34	0.45	918	0.36	0.48	970	0.38	0.51	1018	0.41	0.55	1065	0.43	0.58	1108	0.46	0.62	1150	0.49	0.66	1190	0.52	0.70
849	1800	904	0.38	0.51	957	0.40	0.54	1006	0.43	0.57	1052	0.46	0.61	1096	0.48	0.65	1138	0.51	0.69	1178	0.54	0.73	1217	0.58	0.78
897	1900	946	0.43	0.57	996	0.46	0.61	1042	0.48	0.64	1086	0.51	0.68	1128	0.54	0.72	1168	0.57	0.76	1207	0.60	0.81	1245	0.64	0.86
944	2000	988	0.48	0.64	1035	0.51	0.68	1079	0.54	0.72	1120	0.57	0.76	1161	0.60	0.81	1199	0.63	0.85	1237	0.67	0.90	1275	0.72	0.96
991	2100	1028	0.54	0.72	1073	0.57	0.76	1115	0.60	0.81	1155	0.63	0.85	1194	0.67	0.90	1231	0.71	0.95	1268	0.75	1.01	1305	0.80	1.07
1038	2200	1068	0.60	0.81	1111	0.64	0.86	1151	0.67	0.90	1190	0.71	0.95	1227	0.75	1.00	1263	0.79	1.06	1299	0.84	1.12	1336	0.88	1.18
1085	2300	1108	0.68	0.91	1149	0.72	0.96	1188	0.75	1.01	1225	0.79	1.06	1261	0.84	1.12	1296	0.88	1.18	1332	0.93	1.24	1367	0.98	1.31
1133	2400	1148	0.76	1.02	1187	0.80	1.07	1224	0.84	1.13	1260	0.88	1.18	1295	0.93	1.25	1330	0.98	1.31	1365	1.03	1.38	1400	1.08	1.45

Air Volume		External Static - Pa (in.w.g.)																							
		225 (0.90)		250 (1.00)		275 (1.10)		300 (1.20)		325 (1.30)		350 (1.40)		375 (1.50)		400 (1.60)									
L/s	cfm	Rev/ min	BHP	kW	Rev/ min	BHP	kW	Rev/ min	BHP	kW	Rev/ min	BHP	kW	Rev/ min	BHP	kW	Rev/ min	BHP	kW						
755	1600	1204	0.51	0.68	1245	0.54	0.72	1285	0.57	0.76	1325	0.60	0.81	1363	0.64	0.86	1401	0.68	0.91	1437	0.72	0.96	1473	0.75	1.01
802	1700	1229	0.56	0.75	1269	0.59	0.79	1309	0.63	0.84	1348	0.66	0.89	1386	0.70	0.94	1423	0.75	1.00	1458	0.78	1.05	1493	0.82	1.10
849	1800	1256	0.62	0.83	1295	0.66	0.88	1334	0.69	0.93	1372	0.73	0.98	1409	0.78	1.04	1445	0.81	1.09	1481	0.86	1.15	1515	0.90	1.20
897	1900	1283	0.69	0.92	1322	0.72	0.97	1360	0.77	1.03	1397	0.81	1.08	1434	0.85	1.14	1469	0.90	1.20	1504	0.93	1.25	1537	0.98	1.31
944	2000	1312	0.76	1.02	1350	0.80	1.07	1387	0.84	1.13	1424	0.89	1.19	1459	0.93	1.25	1494	0.98	1.31	1528	1.02	1.37	1561	1.06	1.42
991	2100	1342	0.84	1.13	1378	0.89	1.19	1415	0.93	1.25	1451	0.98	1.31	1486	1.02	1.37	1519	1.07	1.43	1553	1.11	1.49	1586	1.15	1.54
1038	2200	1372	0.93	1.25	1408	0.98	1.31	1444	1.02	1.37	1479	1.07	1.44	1513	1.12	1.50	1546	1.16	1.56	1579	1.20	1.61	1611	1.25	1.67
1085	2300	1403	1.03	1.38	1438	1.07	1.44	1473	1.13	1.51	1507	1.17	1.57	1541	1.22	1.63	1573	1.26	1.69	1606	1.31	1.75	1638	1.34	1.80
1133	2400	1434	1.13	1.52	1469	1.18	1.58	1503	1.23	1.65	1537	1.28	1.71	1569	1.32	1.77	1601	1.37	1.83	1633	1.40	1.88	1665	1.45	1.94

BLOWER DATA - BELT DRIVE - ZGA072 - DOWNFLOW

BLOWER TABLE INCLUDES RESISTANCE FOR BASE UNIT ONLY WITH DRY INDOOR COIL AND AIR FILTERS IN PLACE.
FOR ALL UNITS ADD:

1 - Any factory installed options air resistance (heat section, economizer, wet coil, etc.).

2 - Any field installed accessories air resistance (duct resistance, diffuser, etc.).

See page 35 for blower motors and drives and wet coil and options/accessory air resistance data.

Air Volume		External Static - Pa (in. w.g.)																							
		25 (0.10)		50 (0.20)		75 (0.30)		100 (0.40)		125 (0.50)		150 (0.60)		175 (0.70)		200 (0.80)									
L/s	cfm	Rev/ min	BHP	kW	Rev/ min	BHP	kW	Rev/ min	BHP	kW	Rev/ min	BHP	kW	Rev/ min	BHP	kW	Rev/ min	BHP	kW						
895	1900	600	0.38	0.51	637	0.41	0.55	676	0.45	0.60	714	0.48	0.65	752	0.51	0.69	788	0.56	0.75	823	0.60	0.80	856	0.64	0.86
945	2000	627	0.43	0.57	663	0.46	0.62	701	0.50	0.67	738	0.54	0.72	775	0.57	0.77	810	0.61	0.82	844	0.66	0.88	875	0.70	0.94
990	2100	654	0.48	0.64	690	0.51	0.69	727	0.55	0.74	763	0.59	0.79	798	0.63	0.85	832	0.67	0.90	864	0.72	0.96	894	0.77	1.03
1040	2200	682	0.53	0.71	717	0.57	0.76	753	0.61	0.82	788	0.65	0.87	822	0.69	0.93	854	0.74	0.99	885	0.79	1.06	914	0.84	1.12
1085	2300	709	0.59	0.79	744	0.63	0.85	779	0.67	0.90	813	0.72	0.96	846	0.76	1.02	877	0.81	1.09	906	0.86	1.15	934	0.91	1.22
1135	2400	737	0.65	0.87	771	0.69	0.93	805	0.74	0.99	838	0.79	1.06	870	0.84	1.12	899	0.89	1.19	928	0.94	1.26	954	0.99	1.33
1180	2500	766	0.72	0.97	799	0.77	1.03	832	0.81	1.09	864	0.87	1.16	894	0.92	1.23	922	0.97	1.30	950	1.03	1.38	976	1.08	1.45
1225	2600	794	0.80	1.07	827	0.85	1.14	859	0.90	1.21	889	0.95	1.28	918	1.01	1.35	946	1.07	1.43	972	1.12	1.50	997	1.18	1.58
1275	2700	823	0.88	1.18	855	0.93	1.25	885	0.99	1.33	915	1.04	1.40	943	1.10	1.48	969	1.16	1.56	995	1.22	1.64	1019	1.28	1.71
1320	2800	852	0.97	1.30	882	1.03	1.38	912	1.09	1.46	940	1.15	1.54	967	1.21	1.62	993	1.27	1.70	1018	1.33	1.78	1041	1.39	1.86
1370	2900	881	1.07	1.44	911	1.13	1.52	939	1.19	1.60	967	1.25	1.68	992	1.31	1.76	1017	1.38	1.85	1041	1.44	1.93	1064	1.50	2.01

Air Volume		External Static - Pa (in. w.g.)																							
		225 (0.90)		250 (1.00)		275 (1.10)		300 (1.20)		325 (1.30)		350 (1.40)		375 (1.50)		400 (1.60)									
L/s	cfm	Rev/ min	BHP	kW	Rev/ min	BHP	kW	Rev/ min	BHP	kW	Rev/ min	BHP	kW	Rev/ min	BHP	kW	Rev/ min	BHP	kW						
895	1900	886	0.69	0.92	914	0.74	0.99	940	0.79	1.06	965	0.84	1.12	991	0.89	1.19	1017	0.93	1.25	1043	0.98	1.32	1070	1.03	1.38
945	2000	904	0.75	1.01	930	0.81	1.08	956	0.86	1.15	981	0.90	1.21	1006	0.95	1.28	1032	1.01	1.35	1058	1.05	1.41	1084	1.10	1.47
990	2100	922	0.82	1.10	948	0.87	1.17	973	0.93	1.24	997	0.98	1.31	1022	1.03	1.38	1047	1.07	1.44	1073	1.13	1.51	1099	1.17	1.57
1040	2200	941	0.90	1.20	966	0.95	1.27	990	1.00	1.34	1015	1.05	1.41	1039	1.10	1.48	1064	1.16	1.55	1089	1.20	1.61	1114	1.25	1.68
1085	2300	960	0.97	1.30	984	1.02	1.37	1008	1.08	1.45	1032	1.13	1.52	1056	1.19	1.59	1081	1.24	1.66	1106	1.28	1.72	1131	1.34	1.79
1135	2400	980	1.05	1.41	1004	1.11	1.49	1027	1.16	1.56	1051	1.22	1.63	1075	1.27	1.70	1099	1.32	1.77	1123	1.37	1.84	1148	1.42	1.91
1180	2500	1000	1.14	1.53	1023	1.19	1.60	1046	1.25	1.68	1070	1.31	1.75	1093	1.37	1.83	1117	1.42	1.90	1142	1.47	1.97	1166	1.52	2.04
1225	2600	1021	1.24	1.66	1043	1.29	1.73	1066	1.35	1.81	1089	1.40	1.88	1113	1.46	1.96	1137	1.51	2.03	1161	1.57	2.10	1185	1.62	2.17
1275	2700	1042	1.34	1.79	1064	1.40	1.87	1087	1.45	1.95	1110	1.51	2.02	1133	1.56	2.09	1157	1.62	2.17	1181	1.67	2.24	1205	1.73	2.32
1320	2800	1063	1.45	1.94	1086	1.50	2.01	1108	1.56	2.09	1131	1.62	2.17	1154	1.67	2.24	1177	1.73	2.32	1201	1.78	2.39	1225	1.84	2.47
1370	2900	1086	1.56	2.09	1107	1.62	2.17	1130	1.67	2.24	1152	1.73	2.32	1175	1.79	2.40	1198	1.85	2.48	1222	1.90	2.55	1245	1.95	2.62

BLOWER DATA - BELT DRIVE - ZGA072 - HORIZONTAL

BLOWER TABLE INCLUDES RESISTANCE FOR BASE UNIT ONLY WITH DRY INDOOR COIL AND AIR FILTERS IN PLACE.
FOR ALL UNITS ADD:

1 - Any factory installed options air resistance (heat section, economizer, wet coil, etc.).

2 - Any field installed accessories air resistance (duct resistance, diffuser, etc.).

See page 35 for blower motors and drives and wet coil and options/accessory air resistance data.

Air Volume		External Static - Pa (in. w.g.)																							
		25 (0.10)		50 (0.20)		75 (0.30)		100 (0.40)		125 (0.50)		150 (0.60)		175 (0.70)		200 (0.80)									
L/s	cfm	Rev/ min	kW	BHP	Rev/ min	kW	BHP	Rev/ min	kW	BHP	Rev/ min	kW	BHP	Rev/ min	kW	BHP	Rev/ min	kW	BHP						
895	1900	555	0.31	0.41	593	0.35	0.47	633	0.39	0.52	673	0.43	0.57	713	0.47	0.63	752	0.51	0.68	789	0.55	0.74	824	0.60	0.80
945	2000	573	0.34	0.46	612	0.39	0.52	652	0.43	0.58	692	0.47	0.63	731	0.51	0.69	769	0.56	0.75	805	0.60	0.81	839	0.65	0.87
990	2100	592	0.39	0.52	632	0.43	0.58	671	0.48	0.64	711	0.52	0.70	750	0.57	0.76	787	0.61	0.82	822	0.66	0.88	855	0.71	0.95
1040	2200	613	0.44	0.59	652	0.48	0.65	692	0.53	0.71	731	0.57	0.77	769	0.62	0.83	804	0.66	0.89	838	0.72	0.96	870	0.77	1.03
1085	2300	635	0.49	0.66	674	0.54	0.72	713	0.59	0.79	751	0.63	0.85	788	0.68	0.91	823	0.72	0.97	855	0.78	1.04	887	0.84	1.12
1135	2400	658	0.54	0.73	697	0.60	0.80	735	0.64	0.86	772	0.69	0.93	808	0.74	0.99	841	0.79	1.06	873	0.84	1.13	903	0.90	1.21
1180	2500	682	0.60	0.81	720	0.66	0.88	757	0.71	0.95	793	0.75	1.01	827	0.81	1.08	859	0.86	1.15	890	0.92	1.23	919	0.98	1.31
1225	2600	706	0.67	0.90	743	0.72	0.97	779	0.78	1.04	814	0.83	1.11	847	0.88	1.18	878	0.93	1.25	907	0.99	1.33	936	1.05	1.41
1275	2700	731	0.74	0.99	767	0.79	1.06	802	0.84	1.13	835	0.90	1.21	866	0.95	1.28	896	1.01	1.36	925	1.07	1.44	953	1.13	1.52
1320	2800	756	0.81	1.09	790	0.87	1.16	824	0.93	1.24	856	0.98	1.31	886	1.04	1.39	915	1.10	1.47	943	1.16	1.56	970	1.22	1.64
1370	2900	780	0.89	1.19	814	0.95	1.27	846	1.01	1.35	876	1.07	1.43	906	1.13	1.51	934	1.19	1.59	961	1.25	1.68	987	1.32	1.77

External Static - Pa (in. w.g.)

Air Volume		External Static - Pa (in. w.g.)																							
		225 (0.90)		250 (1.00)		275 (1.10)		300 (1.20)		325 (1.30)		350 (1.40)		375 (1.50)		400 (1.60)									
L/s	cfm	Rev/ min	kW	BHP	Rev/ min	kW	BHP	Rev/ min	kW	BHP	Rev/ min	kW	BHP	Rev/ min	kW	BHP	Rev/ min	kW	BHP						
895	1900	857	0.65	0.87	889	0.69	0.93	919	0.75	1.00	949	0.79	1.06	977	0.84	1.13	1003	0.90	1.20	1029	0.94	1.26	1054	0.99	1.33
945	2000	872	0.70	0.94	903	0.75	1.01	932	0.81	1.08	961	0.86	1.15	988	0.90	1.21	1015	0.95	1.28	1040	1.01	1.35	1064	1.06	1.42
990	2100	886	0.76	1.02	917	0.81	1.09	946	0.87	1.16	974	0.92	1.23	1000	0.97	1.30	1026	1.02	1.37	1051	1.07	1.44	1074	1.13	1.51
1040	2200	901	0.83	1.11	931	0.88	1.18	959	0.93	1.25	987	0.98	1.32	1013	1.04	1.40	1038	1.09	1.46	1062	1.14	1.53	1085	1.19	1.60
1085	2300	917	0.89	1.19	945	0.95	1.27	973	1.01	1.35	1000	1.06	1.42	1026	1.11	1.49	1050	1.16	1.56	1074	1.22	1.63	1096	1.27	1.70
1135	2400	932	0.96	1.29	960	1.02	1.37	987	1.07	1.44	1014	1.13	1.52	1039	1.19	1.60	1063	1.25	1.67	1085	1.30	1.74	1107	1.35	1.81
1180	2500	948	1.04	1.39	975	1.10	1.47	1002	1.16	1.55	1027	1.22	1.63	1052	1.27	1.70	1075	1.33	1.78	1098	1.38	1.85	1119	1.43	1.92
1225	2600	964	1.11	1.49	991	1.18	1.58	1017	1.24	1.66	1041	1.30	1.74	1065	1.36	1.82	1088	1.41	1.89	1110	1.47	1.97	1131	1.52	2.04
1275	2700	980	1.20	1.61	1006	1.26	1.69	1031	1.33	1.78	1056	1.39	1.86	1079	1.45	1.94	1102	1.51	2.02	1123	1.56	2.09	1144	1.61	2.16
1320	2800	996	1.29	1.73	1022	1.36	1.82	1047	1.42	1.90	1071	1.48	1.99	1093	1.54	2.07	1115	1.60	2.15	1136	1.66	2.22	1157	1.71	2.29
1370	2900	1013	1.39	1.86	1038	1.45	1.95	1062	1.51	2.03	1086	1.58	2.12	1108	1.64	2.20	1129	1.70	2.28	1150	1.76	2.36	1171	1.81	2.43

BLOWER DATA - BELT DRIVE - ZGBO36 - DOWNFLOW

BLOWER TABLE INCLUDES RESISTANCE FOR BASE UNIT ONLY WITH DRY INDOOR COIL AND AIR FILTERS IN PLACE.

FOR ALL UNITS ADD:

1 - Any factory installed options air resistance (heat section, economizer, wet coil, etc.).

2 - Any field installed accessories air resistance (duct resistance, diffuser, etc.).

See page 35 for blower motors and drives and wet coil and options/accessory air resistance data.

Air Volume		External Static - Pa (in.w.g.)																							
		25 (0.10)		50 (0.20)		75 (0.30)		100 (0.40)		125 (0.50)		150 (0.60)		175 (0.70)		200 (0.80)									
L/s	cfm	Rev/ min	kW	BHP	Rev/ min	kW	BHP	Rev/ min	kW	BHP	Rev/ min	kW	BHP	Rev/ min	kW	BHP	Rev/ min	kW	BHP						
425	900	573	0.12	0.16	639	0.13	0.18	707	0.14	0.19	776	0.16	0.21	844	0.17	0.23	908	0.19	0.25	967	0.20	0.27	1022	0.22	0.30
472	1000	600	0.13	0.18	665	0.15	0.20	733	0.16	0.22	802	0.17	0.23	868	0.19	0.25	930	0.21	0.28	986	0.23	0.31	1038	0.25	0.33
519	1100	628	0.16	0.21	695	0.16	0.22	762	0.18	0.24	829	0.19	0.26	893	0.22	0.29	953	0.23	0.31	1007	0.26	0.35	1057	0.28	0.38
566	1200	660	0.17	0.23	727	0.19	0.25	794	0.20	0.27	859	0.22	0.29	921	0.24	0.32	977	0.27	0.36	1029	0.29	0.39	1077	0.31	0.42
613	1300	695	0.19	0.26	761	0.21	0.28	827	0.23	0.31	890	0.25	0.33	949	0.28	0.37	1003	0.30	0.40	1053	0.33	0.44	1099	0.35	0.47
661	1400	734	0.22	0.30	799	0.24	0.32	862	0.26	0.35	923	0.28	0.38	978	0.31	0.41	1030	0.34	0.45	1078	0.37	0.49	1122	0.40	0.53
708	1500	775	0.25	0.34	837	0.28	0.37	898	0.30	0.40	955	0.32	0.43	1009	0.34	0.46	1058	0.37	0.50	1104	0.40	0.54	1147	0.43	0.58

Air Volume		External Static - Pa (in.w.g.)																							
		225 (0.90)		250 (1.00)		275 (1.10)		300 (1.20)		325 (1.30)		350 (1.40)		375 (1.50)		400 (1.60)									
L/s	cfm	Rev/ min	kW	BHP	Rev/ min	kW	BHP	Rev/ min	kW	BHP	Rev/ min	kW	BHP	Rev/ min	kW	BHP	Rev/ min	kW	BHP						
425	900	1072	0.24	0.32	1120	0.26	0.35	1166	0.28	0.38	1210	0.31	0.41	1252	0.33	0.44	1292	0.35	0.47	1331	0.37	0.50	1370	0.40	0.54
472	1000	1087	0.27	0.36	1134	0.29	0.39	1179	0.31	0.42	1222	0.34	0.45	1263	0.36	0.48	1303	0.38	0.51	1341	0.41	0.55	1379	0.43	0.58
519	1100	1104	0.30	0.40	1150	0.32	0.43	1194	0.34	0.46	1236	0.37	0.49	1277	0.40	0.53	1315	0.42	0.56	1353	0.45	0.60	1390	0.48	0.64
566	1200	1123	0.34	0.45	1167	0.36	0.48	1210	0.38	0.51	1251	0.41	0.55	1291	0.43	0.58	1330	0.46	0.62	1367	0.49	0.66	1403	0.52	0.70
613	1300	1143	0.37	0.50	1186	0.40	0.54	1228	0.43	0.57	1268	0.45	0.60	1308	0.48	0.64	1346	0.51	0.68	1382	0.54	0.72	1418	0.57	0.76
661	1400	1165	0.42	0.56	1206	0.44	0.59	1247	0.47	0.63	1287	0.50	0.67	1326	0.52	0.70	1363	0.56	0.75	1399	0.59	0.79	1435	0.62	0.83
708	1500	1188	0.46	0.62	1229	0.49	0.66	1269	0.51	0.69	1308	0.54	0.73	1346	0.57	0.77	1382	0.61	0.82	1418	0.64	0.86	1453	0.67	0.90

BLOWER DATA - BELT DRIVE - ZGBO36 - HORIZONTAL

BLOWER TABLE INCLUDES RESISTANCE FOR BASE UNIT ONLY WITH DRY INDOOR COIL AND AIR FILTERS IN PLACE.

FOR ALL UNITS ADD:

1 - Any factory installed options air resistance (heat section, economizer, wet coil, etc.).

2 - Any field installed accessories air resistance (duct resistance, diffuser, etc.).

See page 35 for blower motors and drives and wet coil and options/accessory air resistance data.

Air Volume		External Static - Pa (in.w.g.)																							
		25 (0.10)		50 (0.20)		75 (0.30)		100 (0.40)		125 (0.50)		150 (0.60)		175 (0.70)		200 (0.80)									
L/s	cfm	Rev/ min	kW	BHP	Rev/ min	kW	BHP	Rev/ min	kW	BHP	Rev/ min	kW	BHP	Rev/ min	kW	BHP	Rev/ min	kW	BHP						
425	900	573	0.10	0.14	642	0.12	0.16	712	0.13	0.18	780	0.16	0.21	846	0.17	0.23	909	0.19	0.26	967	0.21	0.28	1022	0.23	0.31
472	1000	599	0.12	0.16	668	0.13	0.18	737	0.16	0.21	804	0.17	0.23	868	0.19	0.26	928	0.22	0.29	984	0.24	0.32	1037	0.26	0.35
519	1100	626	0.13	0.18	695	0.16	0.21	764	0.18	0.24	830	0.19	0.26	892	0.22	0.29	950	0.24	0.32	1003	0.27	0.36	1053	0.29	0.39
566	1200	656	0.16	0.21	726	0.18	0.24	794	0.20	0.27	858	0.22	0.3	918	0.25	0.33	973	0.28	0.37	1024	0.30	0.4	1072	0.32	0.43
613	1300	691	0.19	0.25	761	0.21	0.28	827	0.23	0.31	889	0.25	0.34	945	0.28	0.38	998	0.31	0.41	1047	0.34	0.45	1093	0.36	0.48
661	1400	731	0.22	0.29	798	0.24	0.32	862	0.26	0.35	920	0.29	0.39	974	0.31	0.42	1024	0.34	0.46	1071	0.37	0.49	1115	0.40	0.53
708	1500	773	0.25	0.34	838	0.28	0.37	898	0.30	0.40	952	0.33	0.44	1004	0.35	0.47	1051	0.38	0.51	1096	0.41	0.55	1139	0.43	0.58

Air Volume		External Static - Pa (in.w.g.)																							
		225 (0.90)		250 (1.00)		275 (1.10)		300 (1.20)		325 (1.30)		350 (1.40)		375 (1.50)		400 (1.60)									
L/s	cfm	Rev/ min	kW	BHP	Rev/ min	kW	BHP	Rev/ min	kW	BHP	Rev/ min	kW	BHP	Rev/ min	kW	BHP	Rev/ min	kW	BHP						
425	900	1074	0.25	0.33	1123	0.27	0.36	1171	0.29	0.39	1216	0.31	0.41	1260	0.33	0.44	1301	0.35	0.47	1340	0.37	0.49	1378	0.39	0.52
472	1000	1087	0.28	0.37	1135	0.30	0.4	1181	0.31	0.42	1226	0.34	0.45	1269	0.36	0.48	1310	0.38	0.51	1350	0.40	0.54	1388	0.43	0.57
519	1100	1101	0.31	0.41	1148	0.33	0.44	1193	0.35	0.47	1237	0.37	0.49	1279	0.39	0.52	1321	0.41	0.55	1360	0.44	0.59	1398	0.46	0.62
566	1200	1118	0.34	0.46	1163	0.36	0.48	1208	0.38	0.51	1251	0.40	0.54	1293	0.43	0.58	1334	0.46	0.61	1375	0.48	0.64	1414	0.51	0.68
613	1300	1137	0.38	0.51	1181	0.40	0.53	1224	0.43	0.57	1267	0.45	0.6	1309	0.47	0.63	1350	0.50	0.67	1391	0.53	0.71	1432	0.56	0.75
661	1400	1158	0.42	0.56	1200	0.44	0.59	1242	0.46	0.62	1284	0.49	0.66	1326	0.52	0.7	1367	0.55	0.74	1407	0.59	0.79	1448	0.62	0.83
708	1500	1180	0.46	0.61	1222	0.48	0.65	1263	0.51	0.69	1304	0.54	0.73	1345	0.57	0.77	1386	0.61	0.82	1427	0.65	0.87	1467	0.69	0.92

BLOWER DATA - BELT DRIVE - ZGBO48 - DOWNFLOW

BLOWER TABLE INCLUDES RESISTANCE FOR BASE UNIT ONLY WITH DRY INDOOR COIL AND AIR FILTERS IN PLACE.

FOR ALL UNITS ADD:

1 - Any factory installed options air resistance (heat section, economizer, wet coil, etc.).

2 - Any field installed accessories air resistance (duct resistance, diffuser, etc.).

See page 35 for blower motors and drives and wet coil and options/accessory air resistance data.

Air Volume		External Static - Pa (in. w.g.)																							
		25 (0.10)		50 (0.20)		75 (0.30)		100 (0.40)		125 (0.50)		150 (0.60)		175 (0.70)		200 (0.80)									
L/s	cfm	Rev/ min	kW	BHP	Rev/ min	kW	BHP	Rev/ min	kW	BHP	Rev/ min	kW	BHP	Rev/ min	kW	BHP	Rev/ min	kW	BHP						
566	1200	660	0.17	0.23	727	0.19	0.25	794	0.20	0.27	859	0.22	0.29	921	0.24	0.32	977	0.27	0.36	1029	0.29	0.39	1077	0.31	0.42
613	1300	695	0.19	0.26	761	0.21	0.28	827	0.23	0.31	890	0.25	0.33	949	0.28	0.37	1003	0.30	0.40	1053	0.33	0.44	1099	0.35	0.47
661	1400	734	0.22	0.30	799	0.24	0.32	862	0.26	0.35	923	0.28	0.38	978	0.31	0.41	1030	0.34	0.45	1078	0.37	0.49	1122	0.40	0.53
708	1500	775	0.25	0.34	837	0.28	0.37	898	0.30	0.40	955	0.32	0.43	1009	0.34	0.46	1058	0.37	0.50	1104	0.40	0.54	1147	0.43	0.58
755	1600	817	0.29	0.39	877	0.31	0.42	935	0.34	0.45	989	0.36	0.48	1040	0.39	0.52	1087	0.42	0.56	1131	0.45	0.60	1173	0.48	0.65
802	1700	859	0.33	0.44	917	0.35	0.47	972	0.37	0.50	1023	0.40	0.54	1071	0.43	0.58	1117	0.46	0.62	1159	0.50	0.67	1199	0.53	0.71
849	1800	902	0.37	0.49	957	0.40	0.53	1008	0.42	0.56	1057	0.45	0.60	1103	0.48	0.64	1147	0.51	0.69	1188	0.55	0.74	1227	0.59	0.79
897	1900	944	0.42	0.56	996	0.44	0.59	1045	0.47	0.63	1092	0.51	0.68	1136	0.54	0.72	1178	0.57	0.77	1218	0.61	0.82	1257	0.65	0.87
944	2000	986	0.47	0.63	1035	0.50	0.67	1083	0.53	0.71	1127	0.57	0.76	1170	0.60	0.81	1210	0.64	0.86	1249	0.68	0.91	1287	0.72	0.97

Air Volume		External Static - Pa (in. w.g.)																							
		225 (0.90)		250 (1.00)		275 (1.10)		300 (1.20)		325 (1.30)		350 (1.40)		375 (1.50)		400 (1.60)									
L/s	cfm	Rev/ min	kW	BHP	Rev/ min	kW	BHP	Rev/ min	kW	BHP	Rev/ min	kW	BHP	Rev/ min	kW	BHP	Rev/ min	kW	BHP						
566	1200	1123	0.34	0.45	1167	0.36	0.48	1210	0.38	0.51	1251	0.41	0.55	1291	0.43	0.58	1330	0.46	0.62	1367	0.49	0.66	1403	0.52	0.70
613	1300	1143	0.37	0.50	1186	0.40	0.54	1228	0.43	0.57	1268	0.45	0.60	1308	0.48	0.64	1346	0.51	0.68	1382	0.54	0.72	1418	0.57	0.76
661	1400	1165	0.42	0.56	1206	0.44	0.59	1247	0.47	0.63	1287	0.50	0.67	1326	0.52	0.70	1363	0.56	0.75	1399	0.59	0.79	1435	0.62	0.83
708	1500	1188	0.46	0.62	1229	0.49	0.66	1269	0.51	0.69	1308	0.54	0.73	1346	0.57	0.77	1382	0.61	0.82	1418	0.64	0.86	1453	0.67	0.90
755	1600	1213	0.51	0.69	1252	0.54	0.73	1292	0.57	0.77	1330	0.60	0.81	1367	0.63	0.85	1403	0.66	0.89	1438	0.70	0.94	1472	0.73	0.98
802	1700	1239	0.57	0.76	1278	0.60	0.80	1316	0.63	0.84	1354	0.66	0.89	1390	0.69	0.93	1425	0.73	0.98	1459	0.76	1.02	1492	0.80	1.07
849	1800	1266	0.62	0.83	1304	0.66	0.88	1342	0.69	0.93	1378	0.73	0.98	1414	0.76	1.02	1448	0.80	1.07	1481	0.84	1.12	1514	0.87	1.16
897	1900	1294	0.69	0.92	1332	0.72	0.97	1369	0.76	1.02	1404	0.80	1.07	1439	0.84	1.12	1472	0.87	1.17	1504	0.90	1.21	1536	0.94	1.26
944	2000	1324	0.76	1.02	1360	0.80	1.07	1396	0.84	1.13	1431	0.88	1.18	1465	0.92	1.23	1497	0.95	1.27	1529	0.98	1.32	1560	1.02	1.37

BLOWER DATA - BELT DRIVE - ZGBO48 - HORIZONTAL

BLOWER TABLE INCLUDES RESISTANCE FOR BASE UNIT ONLY WITH DRY INDOOR COIL AND AIR FILTERS IN PLACE.

FOR ALL UNITS ADD:

1 - Any factory installed options air resistance (heat section, economizer, wet coil, etc.).

2 - Any field installed accessories air resistance (duct resistance, diffuser, etc.).

See page 35 for blower motors and drives and wet coil and options/accessory air resistance data.

Air Volume		External Static - Pa (in.w.g.)																							
		25 (0.10)		50 (0.20)		75 (0.30)		100 (0.40)		125 (0.50)		150 (0.60)		175 (0.70)		200 (0.80)									
L/s	cfm	Rev/ min	BHP	Rev/ min	BHP	Rev/ min	BHP	Rev/ min	BHP	Rev/ min	BHP	Rev/ min	BHP	Rev/ min	BHP	Rev/ min	BHP								
566	1200	656	0.16	0.21	726	0.18	0.24	794	0.20	0.27	858	0.22	0.30	918	0.25	0.33	973	0.28	0.37	1024	0.30	0.40	1072	0.32	0.43
613	1300	691	0.19	0.25	761	0.21	0.28	827	0.23	0.31	889	0.25	0.34	945	0.28	0.38	998	0.31	0.41	1047	0.34	0.45	1093	0.36	0.48
661	1400	731	0.22	0.29	798	0.24	0.32	862	0.26	0.35	920	0.29	0.39	974	0.31	0.42	1024	0.34	0.46	1071	0.37	0.49	1115	0.40	0.53
708	1500	773	0.25	0.34	838	0.28	0.37	898	0.30	0.40	952	0.33	0.44	1004	0.35	0.47	1051	0.38	0.51	1096	0.41	0.55	1139	0.43	0.58
755	1600	817	0.29	0.39	878	0.31	0.42	934	0.34	0.46	985	0.37	0.49	1034	0.40	0.53	1080	0.42	0.56	1123	0.45	0.60	1164	0.48	0.64
802	1700	861	0.34	0.45	918	0.36	0.48	970	0.38	0.51	1018	0.41	0.55	1065	0.43	0.58	1108	0.46	0.62	1150	0.49	0.66	1190	0.52	0.70
849	1800	904	0.38	0.51	957	0.40	0.54	1006	0.43	0.57	1052	0.46	0.61	1096	0.48	0.65	1138	0.51	0.69	1178	0.54	0.73	1217	0.58	0.78
897	1900	946	0.43	0.57	996	0.46	0.61	1042	0.48	0.64	1086	0.51	0.68	1128	0.54	0.72	1168	0.57	0.76	1207	0.60	0.81	1245	0.64	0.86
944	2000	988	0.48	0.64	1035	0.51	0.68	1079	0.54	0.72	1120	0.57	0.76	1161	0.60	0.81	1199	0.63	0.85	1237	0.67	0.90	1275	0.72	0.96

Air Volume		External Static - Pa (in.w.g.)																							
		225 (0.90)		250 (1.00)		275 (1.10)		300 (1.20)		325 (1.30)		350 (1.40)		375 (1.50)		400 (1.60)									
L/s	cfm	Rev/ min	BHP	Rev/ min	BHP	Rev/ min	BHP	Rev/ min	BHP	Rev/ min	BHP	Rev/ min	BHP	Rev/ min	BHP	Rev/ min	BHP								
566	1200	1118	0.34	0.46	1163	0.36	0.48	1208	0.38	0.51	1251	0.40	0.54	1293	0.43	0.58	1334	0.46	0.61	1375	0.48	0.64	1414	0.51	0.68
613	1300	1137	0.38	0.51	1181	0.40	0.53	1224	0.43	0.57	1267	0.45	0.60	1309	0.47	0.63	1350	0.50	0.67	1391	0.53	0.71	1432	0.56	0.75
661	1400	1158	0.42	0.56	1200	0.44	0.59	1242	0.46	0.62	1284	0.49	0.66	1326	0.52	0.70	1367	0.55	0.74	1407	0.59	0.79	1448	0.62	0.83
708	1500	1180	0.46	0.61	1222	0.48	0.65	1263	0.51	0.69	1304	0.54	0.73	1345	0.57	0.77	1386	0.61	0.82	1427	0.65	0.87	1467	0.69	0.92
755	1600	1204	0.51	0.68	1245	0.54	0.72	1285	0.57	0.76	1325	0.60	0.80	1366	0.63	0.85	1406	0.67	0.90	1447	0.72	0.96	1487	0.76	1.02
802	1700	1229	0.56	0.75	1269	0.59	0.79	1309	0.63	0.84	1348	0.66	0.89	1388	0.70	0.94	1428	0.75	1.00	1468	0.79	1.06	1508	0.84	1.12
849	1800	1256	0.62	0.83	1295	0.66	0.88	1334	0.69	0.93	1373	0.73	0.98	1412	0.78	1.04	1451	0.82	1.10	1490	0.87	1.16	1529	0.92	1.23
897	1900	1283	0.69	0.92	1322	0.72	0.97	1360	0.77	1.03	1398	0.81	1.09	1436	0.86	1.15	1474	0.90	1.21	1511	0.95	1.27	1549	1.00	1.34
944	2000	1312	0.76	1.02	1350	0.80	1.07	1387	0.84	1.13	1424	0.90	1.20	1461	0.94	1.26	1498	0.98	1.32	1535	1.03	1.38	1571	1.08	1.45

BLOWER DATA - BELT DRIVE - ZGBO60 - DOWNFLOW

BLOWER TABLE INCLUDES RESISTANCE FOR BASE UNIT ONLY WITH DRY INDOOR COIL AND AIR FILTERS IN PLACE.

FOR ALL UNITS ADD:

1 - Any factory installed options air resistance (heat section, economizer, wet coil, etc.).

2 - Any field installed accessories air resistance (duct resistance, diffuser, etc.).

See page 35 for blower motors and drives and wet coil and options/accessory air resistance data.

Air Volume		External Static - Pa (in.w.g.)																							
		25 (0.10)		50 (0.20)		75 (0.30)		100 (0.40)		125 (0.50)		150 (0.60)		175 (0.70)		200 (0.80)									
L/s	cfm	Rev/ min	kW	BHP	Rev/ min	kW	BHP	Rev/ min	kW	BHP	Rev/ min	kW	BHP	Rev/ min	kW	BHP	Rev/ min	kW	BHP						
566	1200	848	0.36	0.48	905	0.40	0.53	961	0.43	0.57	1015	0.46	0.61	1064	0.49	0.66	1107	0.51	0.69	1148	0.54	0.73	1189	0.57	0.76
613	1300	898	0.42	0.56	952	0.45	0.60	1005	0.48	0.65	1054	0.51	0.69	1099	0.54	0.73	1140	0.57	0.77	1180	0.60	0.80	1221	0.62	0.83
661	1400	948	0.47	0.63	998	0.51	0.68	1047	0.54	0.73	1093	0.58	0.78	1136	0.61	0.82	1175	0.63	0.85	1214	0.66	0.88	1255	0.68	0.91
708	1500	996	0.54	0.72	1042	0.57	0.77	1088	0.61	0.82	1132	0.64	0.86	1173	0.67	0.90	1211	0.70	0.94	1250	0.72	0.97	1290	0.75	1.00
755	1600	1041	0.60	0.81	1084	0.64	0.86	1128	0.68	0.91	1170	0.71	0.95	1210	0.74	0.99	1249	0.77	1.03	1287	0.79	1.06	1326	0.82	1.10
802	1700	1084	0.68	0.91	1126	0.71	0.95	1168	0.75	1.00	1209	0.78	1.04	1249	0.81	1.08	1287	0.84	1.12	1324	0.87	1.17	1362	0.90	1.21
849	1800	1128	0.75	1.01	1169	0.78	1.05	1210	0.82	1.10	1250	0.85	1.14	1288	0.89	1.19	1326	0.92	1.23	1363	0.95	1.28	1399	1.00	1.34
897	1900	1173	0.83	1.11	1214	0.87	1.16	1253	0.90	1.20	1292	0.93	1.25	1329	0.97	1.30	1366	1.01	1.36	1402	1.06	1.42	1437	1.10	1.48
944	2000	1220	0.92	1.23	1259	0.95	1.28	1297	0.99	1.33	1335	1.03	1.38	1371	1.07	1.44	1406	1.12	1.50	1442	1.17	1.57	1476	1.22	1.63

Air Volume		External Static - Pa (in.w.g.)																							
		225 (0.90)		250 (1.00)		275 (1.10)		300 (1.20)		325 (1.30)		350 (1.40)		375 (1.50)		400 (1.60)									
L/s	cfm	Rev/ min	kW	BHP	Rev/ min	kW	BHP	Rev/ min	kW	BHP	Rev/ min	kW	BHP	Rev/ min	kW	BHP	Rev/ min	kW	BHP						
566	1200	1232	0.59	0.79	1274	0.61	0.82	1316	0.64	0.86	1356	0.67	0.90	1395	0.70	0.94	1433	0.74	0.99	1470	0.78	1.04	1506	0.81	1.09
613	1300	1263	0.64	0.86	1304	0.67	0.90	1344	0.70	0.94	1383	0.74	0.99	1421	0.78	1.04	1458	0.81	1.09	1494	0.85	1.14	1530	0.89	1.19
661	1400	1295	0.71	0.95	1335	0.74	0.99	1374	0.78	1.04	1412	0.81	1.09	1448	0.85	1.14	1484	0.90	1.20	1520	0.93	1.25	1556	0.97	1.30
708	1500	1329	0.78	1.04	1368	0.81	1.09	1405	0.86	1.15	1441	0.90	1.20	1477	0.94	1.26	1513	0.98	1.31	1548	1.02	1.37	1583	1.06	1.42
755	1600	1364	0.86	1.15	1401	0.90	1.21	1437	0.95	1.27	1472	0.99	1.33	1507	1.03	1.38	1543	1.07	1.44	1578	1.11	1.49	1613	1.15	1.54
802	1700	1399	0.95	1.27	1435	0.99	1.33	1470	1.04	1.40	1505	1.09	1.46	1539	1.13	1.51	1574	1.16	1.56	1609	1.20	1.61	1645	1.24	1.66
849	1800	1435	1.04	1.40	1470	1.10	1.47	1504	1.14	1.53	1538	1.19	1.59	1573	1.23	1.65	1608	1.27	1.70	1642	1.30	1.74	1678	1.34	1.79
897	1900	1472	1.15	1.54	1506	1.20	1.61	1540	1.25	1.67	1574	1.29	1.73	1608	1.33	1.78	1642	1.37	1.83	1677	1.40	1.88	1712	1.44	1.93
944	2000	1510	1.27	1.70	1544	1.31	1.76	1577	1.36	1.82	1610	1.40	1.88	1644	1.44	1.93	1678	1.47	1.97	1713	1.51	2.02	1748	1.54	2.07

BLOWER DATA - BELT DRIVE - ZGBO60 - HORIZONTAL

BLOWER TABLE INCLUDES RESISTANCE FOR BASE UNIT ONLY WITH DRY INDOOR COIL AND AIR FILTERS IN PLACE.

FOR ALL UNITS ADD:

1 - Any factory installed options air resistance (heat section, economizer, wet coil, etc.).

2 - Any field installed accessories air resistance (duct resistance, diffuser, etc.).

See page 35 for blower motors and drives and wet coil and options/accessory air resistance data.

Air Volume		External Static - Pa (in.w.g.)																							
		25 (0.10)		50 (0.20)		75 (0.30)		100 (0.40)		125 (0.50)		150 (0.60)		175 (0.70)		200 (0.80)									
L/s	cfm	Rev/min	BHP	Rev/min	BHP	Rev/min	BHP	Rev/min	BHP	Rev/min	BHP	Rev/min	BHP	Rev/min	BHP	Rev/min	BHP								
566	1200	761	0.32	0.43	820	0.35	0.47	879	0.39	0.52	937	0.42	0.56	994	0.46	0.61	1045	0.48	0.65	1090	0.51	0.69	1132	0.54	0.72
613	1300	803	0.37	0.49	861	0.40	0.53	918	0.43	0.58	973	0.47	0.63	1025	0.50	0.67	1072	0.54	0.72	1114	0.56	0.75	1155	0.58	0.78
661	1400	846	0.42	0.56	901	0.45	0.60	955	0.48	0.65	1008	0.52	0.70	1056	0.56	0.75	1099	0.59	0.79	1140	0.61	0.82	1181	0.63	0.85
708	1500	889	0.47	0.63	941	0.51	0.68	993	0.54	0.73	1042	0.58	0.78	1087	0.62	0.83	1129	0.65	0.87	1168	0.67	0.90	1209	0.69	0.93
755	1600	933	0.53	0.71	981	0.57	0.76	1030	0.60	0.81	1076	0.64	0.86	1119	0.68	0.91	1159	0.71	0.95	1198	0.73	0.98	1238	0.75	1.01
802	1700	974	0.59	0.79	1020	0.63	0.85	1065	0.67	0.90	1109	0.72	0.96	1151	0.75	1.00	1190	0.78	1.04	1229	0.80	1.07	1268	0.83	1.11
849	1800	1013	0.66	0.89	1057	0.70	0.94	1100	0.74	0.99	1143	0.78	1.05	1183	0.81	1.09	1222	0.84	1.13	1261	0.87	1.17	1299	0.90	1.21
897	1900	1050	0.74	0.99	1093	0.78	1.04	1135	0.81	1.09	1177	0.85	1.14	1217	0.88	1.18	1255	0.92	1.23	1293	0.95	1.27	1331	0.98	1.32
944	2000	1088	0.81	1.09	1129	0.85	1.14	1170	0.89	1.19	1211	0.92	1.23	1250	0.95	1.28	1289	0.99	1.33	1326	1.03	1.38	1363	1.07	1.44

Air Volume		External Static - Pa (in.w.g.)																							
		225 (0.90)		250 (1.00)		275 (1.10)		300 (1.20)		325 (1.30)		350 (1.40)		375 (1.50)		400 (1.60)									
L/s	cfm	Rev/min	BHP	Rev/min	BHP	Rev/min	BHP	Rev/min	BHP	Rev/min	BHP	Rev/min	BHP	Rev/min	BHP	Rev/min	BHP								
566	1200	1175	0.57	0.76	1218	0.59	0.79	1260	0.61	0.82	1302	0.63	0.85	1343	0.66	0.89	1383	0.69	0.93	1421	0.73	0.98	1458	0.77	1.03
613	1300	1198	0.61	0.82	1241	0.63	0.85	1283	0.66	0.89	1324	0.69	0.93	1364	0.72	0.97	1402	0.76	1.02	1439	0.80	1.07	1476	0.84	1.12
661	1400	1223	0.66	0.89	1265	0.69	0.92	1307	0.72	0.96	1347	0.75	1.01	1386	0.79	1.06	1423	0.83	1.11	1459	0.87	1.16	1495	0.90	1.21
708	1500	1250	0.72	0.96	1292	0.75	1.01	1332	0.78	1.05	1371	0.82	1.10	1408	0.86	1.15	1445	0.90	1.21	1481	0.95	1.27	1516	0.98	1.32
755	1600	1279	0.78	1.05	1319	0.82	1.10	1358	0.86	1.15	1396	0.90	1.20	1432	0.94	1.26	1468	0.98	1.32	1504	1.03	1.38	1539	1.07	1.44
802	1700	1308	0.86	1.15	1347	0.90	1.20	1385	0.94	1.26	1421	0.98	1.32	1457	1.03	1.38	1493	1.07	1.44	1528	1.12	1.50	1563	1.16	1.56
849	1800	1338	0.94	1.26	1376	0.98	1.31	1412	1.03	1.38	1448	1.08	1.45	1483	1.13	1.51	1518	1.17	1.57	1553	1.22	1.63	1588	1.25	1.68
897	1900	1368	1.02	1.37	1405	1.07	1.44	1441	1.13	1.51	1476	1.18	1.58	1510	1.22	1.64	1545	1.27	1.70	1580	1.31	1.76	1615	1.35	1.81
944	2000	1400	1.12	1.50	1435	1.17	1.57	1470	1.23	1.65	1505	1.28	1.72	1539	1.33	1.78	1573	1.37	1.84	1608	1.41	1.89	1643	1.45	1.94

BLOWER DATA - BELT DRIVE - ZGBO74 - DOWNFLOW

BLOWER TABLE INCLUDES RESISTANCE FOR BASE UNIT ONLY WITH DRY INDOOR COIL AND AIR FILTERS IN PLACE.

FOR ALL UNITS ADD:

1 - Any factory installed options air resistance (heat section, economizer, wet coil, etc.).

2 - Any field installed accessories air resistance (duct resistance, diffuser, etc.).

See page 35 for blower motors and drives and wet coil and options/accessory air resistance data.

Air Volume		External Static - Pa (in.w.g.)																							
		25 (0.10)		50 (0.20)		75 (0.30)		100 (0.40)		125 (0.50)		150 (0.60)		175 (0.70)		200 (0.80)									
L/s	cfm	Rev/ min	BHP	kW	Rev/ min	BHP	kW	Rev/ min	BHP	kW	Rev/ min	BHP	kW	Rev/ min	BHP	kW	Rev/ min	BHP	kW						
900	1900	578	0.33	0.44	610	0.37	0.49	643	0.40	0.54	678	0.45	0.60	714	0.48	0.65	749	0.52	0.70	785	0.57	0.76	819	0.61	0.82
945	2000	600	0.37	0.50	632	0.42	0.56	665	0.46	0.61	699	0.49	0.66	734	0.53	0.71	769	0.57	0.77	803	0.62	0.83	837	0.67	0.90
990	2100	623	0.43	0.57	655	0.46	0.62	688	0.51	0.68	721	0.54	0.73	755	0.59	0.79	789	0.63	0.84	822	0.68	0.91	854	0.73	0.98
1040	2200	647	0.48	0.65	678	0.52	0.70	711	0.56	0.75	743	0.60	0.81	776	0.64	0.86	809	0.69	0.93	841	0.75	1.00	872	0.79	1.06
1085	2300	671	0.54	0.73	702	0.58	0.78	734	0.62	0.83	766	0.66	0.89	798	0.71	0.95	829	0.76	1.02	860	0.81	1.09	890	0.87	1.16
1135	2400	696	0.60	0.81	726	0.65	0.87	757	0.69	0.92	788	0.73	0.98	819	0.78	1.04	850	0.83	1.11	880	0.89	1.19	909	0.94	1.26
1180	2500	720	0.67	0.90	750	0.71	0.95	780	0.75	1.01	811	0.80	1.07	841	0.85	1.14	871	0.91	1.22	900	0.97	1.30	929	1.02	1.37
1225	2600	745	0.74	0.99	774	0.78	1.05	804	0.83	1.11	834	0.87	1.17	864	0.93	1.25	893	0.99	1.33	921	1.05	1.41	949	1.11	1.49
1275	2700	770	0.81	1.09	799	0.86	1.15	828	0.90	1.21	858	0.95	1.28	887	1.01	1.36	916	1.07	1.44	943	1.14	1.53	969	1.20	1.61
1320	2800	795	0.89	1.19	824	0.93	1.25	853	0.99	1.33	882	1.04	1.40	911	1.10	1.48	939	1.16	1.56	965	1.23	1.65	990	1.29	1.73
1370	2900	820	0.97	1.30	849	1.02	1.37	878	1.08	1.45	907	1.14	1.53	935	1.20	1.61	962	1.27	1.70	988	1.33	1.78	1012	1.39	1.86

External Static - Pa (in.w.g.)

Air Volume		External Static - Pa (in.w.g.)																							
		820		250 (1.00)		275 (1.10)		300 (1.20)		325 (1.30)		350 (1.40)		375 (1.50)		400 (1.60)									
L/s	cfm	Rev/ min	BHP	kW	Rev/ min	BHP	kW	Rev/ min	BHP	kW	Rev/ min	BHP	kW	Rev/ min	BHP	kW	Rev/ min	BHP	kW						
900	1900	853	0.66	0.88	885	0.70	0.94	915	0.74	0.99	944	0.78	1.05	971	0.83	1.11	996	0.87	1.17	1021	0.92	1.23	1045	0.96	1.29
945	2000	869	0.72	0.96	899	0.75	1.01	929	0.80	1.07	957	0.84	1.13	984	0.89	1.19	1009	0.93	1.25	1033	0.98	1.31	1058	1.03	1.38
990	2100	885	0.78	1.04	915	0.82	1.10	944	0.86	1.15	971	0.91	1.22	997	0.95	1.28	1022	1.00	1.34	1046	1.04	1.40	1070	1.09	1.46
1040	2200	902	0.84	1.13	931	0.89	1.19	959	0.93	1.24	986	0.98	1.31	1012	1.02	1.37	1036	1.07	1.43	1060	1.12	1.50	1084	1.16	1.56
1085	2300	920	0.92	1.23	948	0.96	1.29	975	1.01	1.35	1001	1.05	1.41	1027	1.10	1.47	1051	1.14	1.53	1075	1.19	1.60	1098	1.24	1.66
1135	2400	938	0.99	1.33	965	1.04	1.39	992	1.08	1.45	1017	1.13	1.52	1042	1.18	1.58	1066	1.22	1.64	1090	1.27	1.70	1113	1.32	1.77
1180	2500	956	1.07	1.44	983	1.13	1.51	1009	1.17	1.57	1034	1.22	1.63	1059	1.26	1.69	1082	1.31	1.75	1105	1.36	1.82	1128	1.40	1.88
1225	2600	975	1.16	1.56	1001	1.22	1.63	1026	1.26	1.69	1051	1.31	1.75	1075	1.35	1.81	1098	1.40	1.87	1121	1.44	1.93	1143	1.49	2.00
1275	2700	995	1.25	1.68	1020	1.31	1.75	1044	1.35	1.81	1069	1.40	1.87	1092	1.44	1.93	1114	1.48	1.99	1136	1.54	2.06	1158	1.59	2.13
1320	2800	1015	1.35	1.81	1039	1.40	1.87	1063	1.45	1.94	1086	1.49	2.00	1109	1.54	2.06	1131	1.58	2.12	1152	1.63	2.19	1174	1.69	2.26
1370	2900	1035	1.45	1.94	1058	1.49	2.00	1081	1.54	2.07	1104	1.59	2.13	1126	1.63	2.19	1147	1.69	2.26	1168	1.74	2.33	1189	1.79	2.40

BLOWER DATA - BELT DRIVE - ZGBO74 - HORIZONTAL

BLOWER TABLE INCLUDES RESISTANCE FOR BASE UNIT ONLY WITH DRY INDOOR COIL AND AIR FILTERS IN PLACE.

FOR ALL UNITS ADD:

1 - Any factory installed options air resistance (heat section, economizer, wet coil, etc.).

2 - Any field installed accessories air resistance (duct resistance, diffuser, etc.).

See page 35 for blower motors and drives and wet coil and options/accessory air resistance data.

Air Volume		External Static - Pa (in.w.g.)																							
		25 (0.10)		50 (0.20)		75 (0.30)		100 (0.40)		125 (0.50)		150 (0.60)		175 (0.70)		200 (0.80)									
L/s	cfm	Rev/min	kW	BHP	Rev/min	kW	BHP	Rev/min	kW	BHP	Rev/min	kW	BHP	Rev/min	kW	BHP	Rev/min	kW	BHP						
900	1900	581	0.33	0.44	618	0.37	0.49	655	0.40	0.54	692	0.44	0.59	729	0.48	0.64	765	0.51	0.69	800	0.56	0.75	833	0.60	0.80
945	2000	602	0.37	0.50	639	0.41	0.55	676	0.46	0.61	713	0.49	0.66	749	0.53	0.71	784	0.57	0.76	818	0.61	0.82	850	0.66	0.88
990	2100	625	0.43	0.57	661	0.46	0.62	698	0.50	0.67	735	0.54	0.73	770	0.58	0.78	804	0.63	0.84	837	0.67	0.90	868	0.72	0.96
1040	2200	648	0.48	0.64	685	0.51	0.69	721	0.56	0.75	757	0.60	0.80	791	0.64	0.86	824	0.69	0.92	856	0.73	0.98	886	0.78	1.05
1085	2300	673	0.53	0.71	709	0.57	0.77	745	0.62	0.83	780	0.66	0.88	813	0.70	0.94	845	0.75	1.01	876	0.81	1.08	905	0.86	1.15
1135	2400	699	0.59	0.79	734	0.63	0.85	769	0.68	0.91	803	0.72	0.97	835	0.78	1.04	866	0.83	1.11	896	0.88	1.18	924	0.93	1.25
1180	2500	725	0.66	0.88	759	0.70	0.94	793	0.75	1.00	826	0.80	1.07	857	0.85	1.14	887	0.90	1.21	916	0.95	1.28	944	1.01	1.36
1225	2600	752	0.72	0.97	785	0.78	1.04	818	0.82	1.10	850	0.87	1.17	880	0.93	1.25	909	0.98	1.32	937	1.04	1.40	964	1.10	1.48
1275	2700	779	0.80	1.07	811	0.85	1.14	843	0.90	1.21	873	0.96	1.29	902	1.02	1.37	931	1.07	1.44	958	1.13	1.52	984	1.19	1.60
1320	2800	805	0.88	1.18	837	0.94	1.26	868	0.99	1.33	897	1.05	1.41	925	1.11	1.49	952	1.17	1.57	979	1.24	1.66	1004	1.30	1.74
1370	2900	832	0.97	1.30	863	1.03	1.38	892	1.09	1.46	921	1.15	1.54	948	1.22	1.63	974	1.28	1.71	1000	1.34	1.80	1024	1.40	1.88
Air Volume		External Static - Pa (in.w.g.)																							
		225 (0.90)		250 (1.00)		275 (1.10)		300 (1.20)		325 (1.30)		350 (1.40)		375 (1.50)		400 (1.60)									
L/s	cfm	Rev/min	kW	BHP	Rev/min	kW	BHP	Rev/min	kW	BHP	Rev/min	kW	BHP	Rev/min	kW	BHP	Rev/min	kW	BHP						
900	1900	864	0.65	0.87	895	0.69	0.93	924	0.74	0.99	953	0.79	1.06	980	0.84	1.12	1007	0.88	1.18	1032	0.93	1.25	1056	0.98	1.31
945	2000	881	0.71	0.95	911	0.75	1.01	940	0.81	1.08	967	0.85	1.14	994	0.90	1.21	1020	0.95	1.27	1044	1.00	1.34	1068	1.04	1.40
990	2100	898	0.77	1.03	927	0.82	1.10	955	0.87	1.17	982	0.92	1.23	1008	0.97	1.30	1033	1.02	1.37	1057	1.07	1.43	1080	1.12	1.50
1040	2200	916	0.84	1.12	944	0.89	1.19	971	0.94	1.26	998	0.99	1.33	1023	1.04	1.40	1047	1.10	1.47	1071	1.15	1.54	1093	1.19	1.60
1085	2300	934	0.91	1.22	961	0.96	1.29	988	1.01	1.36	1014	1.07	1.43	1038	1.12	1.50	1062	1.18	1.58	1085	1.23	1.65	1107	1.28	1.71
1135	2400	952	0.98	1.32	979	1.04	1.40	1005	1.10	1.47	1030	1.15	1.54	1054	1.21	1.62	1077	1.26	1.69	1099	1.31	1.76	1121	1.37	1.83
1180	2500	971	1.07	1.43	997	1.13	1.51	1022	1.19	1.59	1046	1.24	1.66	1069	1.30	1.74	1092	1.35	1.81	1114	1.40	1.88	1135	1.45	1.95
1225	2600	990	1.16	1.55	1015	1.22	1.63	1039	1.28	1.71	1063	1.34	1.79	1086	1.39	1.86	1108	1.45	1.94	1129	1.50	2.01	1150	1.54	2.07
1275	2700	1009	1.25	1.68	1034	1.31	1.76	1057	1.37	1.84	1080	1.43	1.92	1102	1.48	1.99	1124	1.54	2.07	1145	1.60	2.14	1166	1.65	2.21
1320	2800	1028	1.36	1.82	1052	1.42	1.90	1075	1.48	1.98	1097	1.54	2.06	1119	1.59	2.13	1140	1.65	2.21	1161	1.70	2.28	1182	1.75	2.34
1370	2900	1048	1.46	1.96	1071	1.52	2.04	1093	1.58	2.12	1115	1.64	2.20	1136	1.70	2.28	1157	1.75	2.35	1177	1.81	2.42	1198	1.85	2.48

BLOWER DATA

BELT DRIVE KIT SPECIFICATIONS - ZGA/ZGB036-060

Model No.	Motor kW (HP)		No. of Speeds	Drive Kits and Rev/Min Range					
	Nominal	Maximum		ZA07	ZA08	ZA09	ZA10	¹ ZA11	² ZA12
036	0.62 (0.83)	0.71 (0.95)	1	705 - 1077	---	---	1025 - 1391	---	---
	0.93 (1.25)	1.07 (1.43)	1	705 - 1077	---	---	1025 - 1391	---	---
048	0.62 (0.83)	0.71 (0.95)	1	---	759 - 1158	---	---	1111 - 1437	---
	0.93 (1.25)	1.07 (1.43)	1	---	759 - 1158	---	---	1111 - 1437	---
060	0.93 (1.25)	1.07 (1.43)	1	---	---	919 - 1247	---	---	1190 - 1540
	1.24 (1.66)	1.42 (1.91)	1	---	---	919 - 1247	---	---	1190 - 1540

NOTE - Using total air volume and system static pressure requirements determine from blower performance tables rev/min and motor size required. Maximum usable size of motors furnished are shown. If motors of comparable size are used, be sure to keep within the service factor limitations outlined on the motor nameplate.

¹ ZA11 drive kits require the 0.93 kW (1.25 hp) motor.

² ZA12 drive kit requires the 1.24 kW (1.66 hp) motor.

BELT DRIVE KIT SPECIFICATIONS - ZGA072/ZGB074

Model No.	Motor kW (HP)		No. of Speeds	Drive Kits and Rev/Min Range		
	Nominal	Maximum		ZAA03	ZAA04	ZAA05
072	0.93 (1.25)	1.07 (1.43)	1	665 - 921	768 - 1023	921 - 1177
	1.24 (1.66)	1.42 (1.91)	1	665 - 921	768 - 1023	921 - 1177
074	1.24 (1.66)	1.42 (1.91)	2	665 - 921	768 - 1023	921 - 1177

NOTE - Using total air volume and system static pressure requirements determine from blower performance tables rev/min and motor size required. Maximum usable size of motors furnished are shown. If motors of comparable size are used, be sure to keep within the service factor limitations outlined on the motor nameplate.

POWER EXHAUST FAN PERFORMANCE

Return Air System Static Pressure			Air Volume Exhausted	
Pa	in. w.g.		L/s	cfm
0	0.00		880	1865
12	0.05		842	1785
25	0.10		807	1710
37	0.15		769	1630
50	0.20		729	1545
62	0.25		684	1450
75	0.30		637	1350
87	0.35		585	1240

OPTIONS / ACCESSORIES AIR RESISTANCE

Air Volume		Wet Indoor Coil								Gas Heat Exchanger				Economizer			
		ZGA036, ZGA048		ZGB036, ZGB048		ZGA060		ZGB060, ZGA072, ZGB074		Medium		High		Downflow		Horizontal	
L/s	cfm	Pa	in. w.g.	Pa	in. w.g.	Pa	in. w.g.	Pa	in. w.g.	Pa	in. w.g.	Pa	in. w.g.	Pa	in. w.g.	Pa	in. w.g.
425	900	2	0.01	2	0.01	---	---	---	---	0.01	0.05	0.01	0.06	7	0.03	10	0.04
472	1000	2	0.01	5	0.02	---	---	---	---	0.01	0.06	0.01	0.06	7	0.03	12	0.05
519	1100	5	0.02	5	0.02	---	---	---	---	0.01	0.06	0.02	0.07	10	0.04	12	0.05
566	1200	5	0.02	5	0.02	---	---	---	---	0.01	0.06	0.02	0.07	12	0.05	15	0.06
613	1300	5	0.02	7	0.03	---	---	---	---	0.02	0.07	0.02	0.07	12	0.05	17	0.07
661	1400	7	0.03	7	0.03	---	---	---	---	0.02	0.07	0.02	0.08	15	0.06	20	0.08
708	1500	7	0.03	10	0.04	---	---	---	---	0.02	0.07	0.02	0.08	17	0.07	20	0.08
755	1600	7	0.03	10	0.04	10	0.04	7	0.03	0.02	0.07	0.02	0.08	20	0.08	22	0.09
802	1700	10	0.04	12	0.05	12	0.05	7	0.03	0.02	0.07	0.02	0.08	22	0.09	25	0.10
849	1800	10	0.04	12	0.05	12	0.05	7	0.03	0.01	0.06	0.02	0.08	25	0.10	27	0.11
897	1900	10	0.04	15	0.06	15	0.06	10	0.04	0.01	0.06	0.02	0.08	27	0.11	30	0.12
944	2000	12	0.05	15	0.06	15	0.06	10	0.04	0.02	0.07	0.02	0.09	30	0.12	32	0.13
991	2100	---	---	---	---	17	0.07	12	0.05	0.02	0.08	0.02	0.10	32	0.13	35	0.14
1038	2200	---	---	---	---	20	0.08	12	0.05	0.02	0.10	0.03	0.12	35	0.14	37	0.15
1085	2300	---	---	---	---	20	0.08	12	0.05	0.03	0.11	0.03	0.14	37	0.15	40	0.16
1133	2400	---	---	---	---	22	0.09	15	0.06	0.03	0.11	0.03	0.13	40	0.16	45	0.18
1180	2500	---	---	---	---	---	---	15	0.06	0.03	0.11	0.04	0.15	45	0.18	47	0.19
1227	2600	---	---	---	---	---	---	17	0.07	0.03	0.13	0.04	0.16	47	0.19	50	0.20
1274	2700	---	---	---	---	---	---	17	0.07	0.04	0.15	0.04	0.18	50	0.20	52	0.21
1321	2800	---	---	---	---	---	---	17	0.07	0.03	0.13	0.04	0.16	55	0.22	57	0.23
1369	2900	---	---	---	---	---	---	20	0.08	0.03	0.13	0.04	0.18	57	0.23	60	0.24

BLOWER DATA

CEILING DIFFUSERS AIR RESISTANCE

Air Volume		RTD9-65S Step-Down Diffuser						FD9-65S Flush Diffuser		RTD11-95S Step-Down Diffuser						FD11-95S Flush Diffuser	
		2 Ends Open		1 Side & 2 Ends Open		All Ends & Sides Open				2 Ends Open		1 Side & 2 Ends Open		All Ends & Sides Open			
L/s	cfm	Pa	in. w.g.	Pa	in. w.g.	Pa	in. w.g.	Pa	in. w.g.	Pa	in. w.g.	Pa	in. w.g.	Pa	in. w.g.	Pa	in. w.g.
375	800	37	0.15	32	0.13	27	0.11	27	0.11	---	---	---	---	---	---	---	---
470	1000	47	0.19	40	0.16	35	0.14	35	0.14	---	---	---	---	---	---	---	---
565	1200	62	0.25	50	0.20	42	0.17	42	0.17	---	---	---	---	---	---	---	---
660	1400	82	0.33	65	0.26	50	0.20	50	0.20	---	---	---	---	---	---	---	---
755	1600	107	0.43	80	0.32	50	0.20	50	0.24	---	---	---	---	---	---	---	---
850	1800	139	0.56	99	0.40	75	0.30	75	0.30	32	0.13	27	0.11	22	0.09	22	0.09
945	2000	182	0.73	124	0.50	90	0.36	90	0.36	37	0.15	32	0.13	27	0.11	25	0.10
1040	2200	236	0.95	157	0.63	109	0.44	109	0.44	45	0.18	37	0.15	30	0.12	30	0.12
1130	2400	---	---	---	---	---	---	---	---	52	0.21	45	0.18	37	0.15	35	0.14
1225	2600	---	---	---	---	---	---	---	---	60	0.24	52	0.21	45	0.18	42	0.17
1320	2800	---	---	---	---	---	---	---	---	67	0.27	60	0.24	52	0.21	50	0.20
1415	3000	---	---	---	---	---	---	---	---	80	0.32	72	0.29	62	0.25	62	0.25
1510	3200	---	---	---	---	---	---	---	---	102	0.41	92	0.37	80	0.32	77	0.31
1605	3400	---	---	---	---	---	---	---	---	124	0.50	112	0.45	97	0.39	92	0.37
1700	3600	---	---	---	---	---	---	---	---	152	0.61	134	0.54	119	0.48	109	0.44

CEILING DIFFUSER AIR THROW DATA

Air Volume		¹ Effective Throw			
Model No.		RTD9-65S		FD9-65S	
L/s	cfm	m	ft.	m	ft.
375	800	3 - 5	10 - 17	4 - 5	14 - 18
470	1000	3 - 5	10 - 17	5 - 6	15 - 20
565	1200	3 - 5	11 - 18	5 - 7	16 - 22
660	1400	4 - 6	12 - 19	5 - 7	17 - 24
755	1600	4 - 6	12 - 20	5 - 8	18 - 25
850	1800	4 - 6	13 - 21	6 - 9	20 - 28
945	2000	4 - 7	14 - 23	6 - 9	21 - 29
1040	2200	5 - 8	16 - 25	7 - 9	22 - 30
Model No.		RTD11-95S		FD11-95S	
1225	2600	7 - 9	24 - 29	6 - 7	19 - 24
1320	2800	8 - 9	25 - 30	6 - 9	20 - 28
1415	3000	8 - 10	27 - 33	6 - 9	21 - 29
1510	3200	9 - 11	28 - 35	7 - 9	22 - 29
1605	3400	9 - 11	30 - 37	7 - 9	22 - 30
1700	3600	8 - 10	25 - 33	7 - 8	22 - 24

¹ Effective throw based on terminal velocities of 23 m per minute (75 ft. per minute).

ELECTRICAL DATA - ZGA

Model No.		ZGA036S4		ZGA048S4		ZGA060S4		ZGA072S4	
¹ Voltage - 50hz with Neutral		380/420V - 3 Ph		380/420V - 3 Ph		380/420V - 3 Ph		380/420V - 3 Ph	
Compressor	Rated Load Amps	4		5.5		8		8	
	Locked Rotor Amps	31		37		59		67	
Outdoor Fan Motor	Full Load Amps	0.6		0.9		1		1	
Power Exhaust (1) 0.25 kW	Full Load Amps	0.6		0.6		0.6		0.6	
Indoor Blower Motor	kW	0.62	0.93	0.62	0.93	0.93	1.24	0.93	1.24
	Full Load Amps	1.6	2	1.6	2	2	2.6	2	2.6
² Maximum Overcurrent Protection	Unit Only	15	15	15	15	20	20	20	20
	With (1) 0.25 kW Power Exhaust	15	15	15	15	20	20	20	20
³ Minimum Circuit Ampacity	Unit Only	8	8	10	10	13	14	13	14
	With (1) 0.25 kW Power Exhaust	8	9	10	11	14	15	14	15

¹ Extremes of operating range are plus and minus 10% of line voltage.

² Heating, Air Conditioning, Refrigeration type breaker or fuse.

³ Refer to local electrical code to determine wire, fuse and disconnect size requirements.

ELECTRICAL DATA - ZGB

Model No.		ZGB036S4		ZGB048S4		ZGB060S4		ZGB074S4	
¹ Voltage - 50hz with Neutral		380/420V - 3 Ph		380/420V - 3 Ph		380/420V - 3 Ph		380/420V - 3 Ph	
Compressor	Rated Load Amps	4		5.5		8		8.5	
	Locked Rotor Amps	31		37		59		66	
Outdoor Fan Motor	Full Load Amps	0.9		0.9		0.9		1	
Power Exhaust (1) 0.25 kW	Full Load Amps	0.6		0.6		0.6		1.3	
Indoor Blower Motor	kW	0.62	0.93	0.62	0.93	0.93	1.24	1.24	
	Full Load Amps	1.6	2	1.6	2	2	2.6	2.6	
² Maximum Overcurrent Protection	Unit Only	15	15	15	15	20	20	20	
	With (1) 0.25 kW Power Exhaust	15	15	15	15	20	20	20	
³ Minimum Circuit Ampacity	Unit Only	8	8	10	10	13	14	15	
	With (1) 0.25 kW Power Exhaust	9	9	10	11	14	15	16	

¹ Extremes of operating range are plus and minus 10% of line voltage.

² Heating, Air Conditioning, Refrigeration type breaker or fuse.

³ Refer to local electrical code to determine wire, fuse and disconnect size requirements.

UNIT CLEARANCES - INCHES (MM)

UNIT WITH DOWNFLOW ECONOMIZER

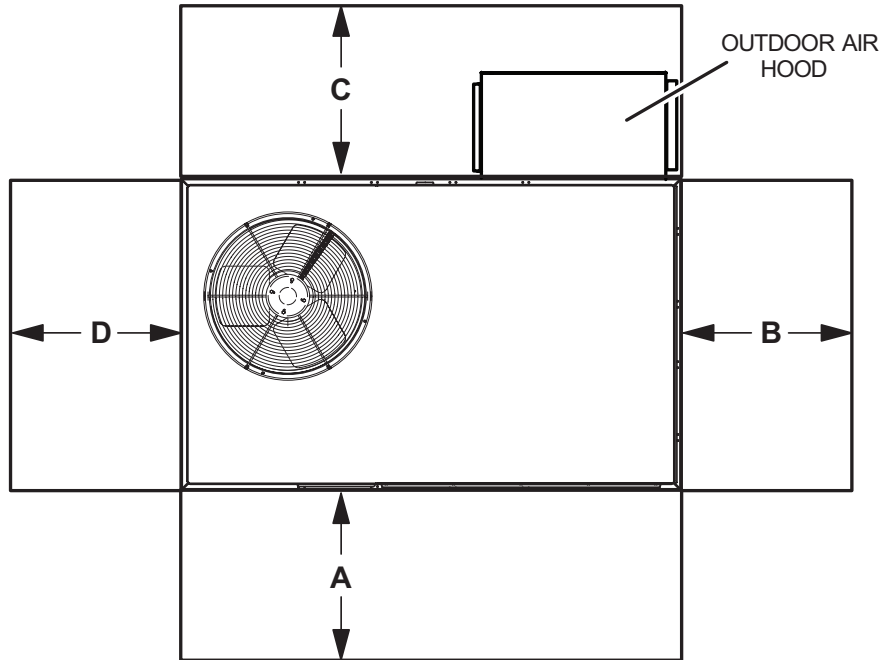

UNIT WITH HORIZONTAL ECONOMIZER

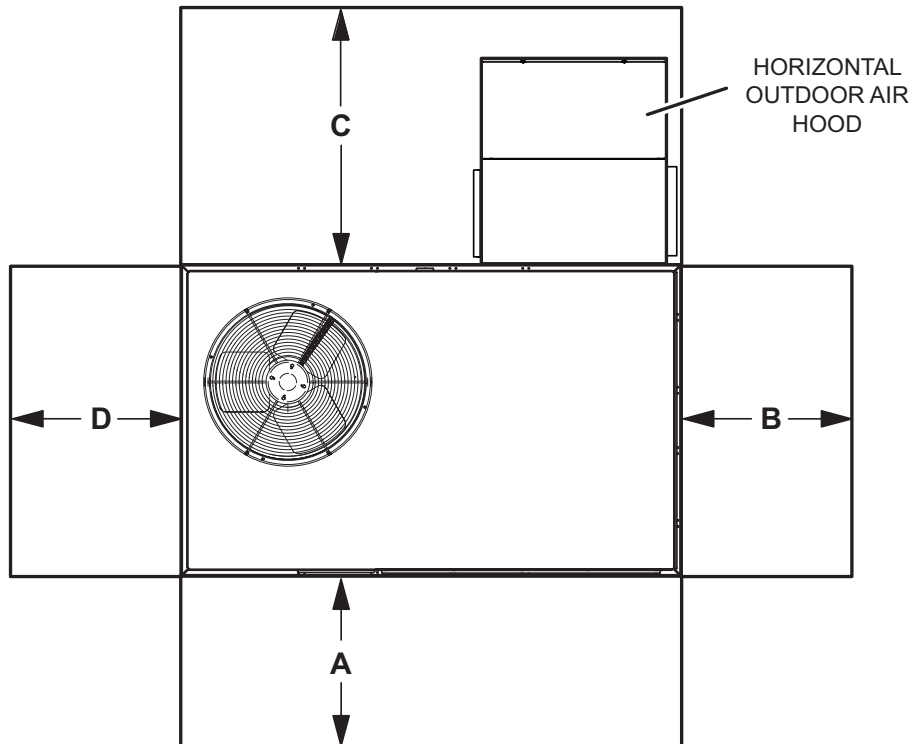

1 Unit Clearance	A		B		C Downflow		C Horizontal		D		Top Clearance
	mm	in.	mm	in.	mm	in.	mm	in.	mm	in.	
Service Clearance	914	36	914	36	914	36	1524	60	914	36	Unobstructed
Clearance to Combustibles	914	36	25	1	25	1	25	1	25	1	
Minimum Operation Clearance	914	36	914	36	914	36	1524	60	914	36	

NOTE - Entire perimeter of unit base requires support when elevated above the mounting surface.

¹ Service Clearance - Required for removal of serviceable parts.

Minimum Operation Clearance - Required clearance for proper unit operation.

OUTDOOR SOUND DATA

Unit Model No.	Octave Band Linear Sound Power Levels dB, re 10 ⁻¹² Watts - Center Frequency - Hz							¹ Sound Rating Number (SRN) (dBA)
	125	250	500	1000	2000	4000	8000	
ZGA036	81	78	77	72	68	66	61	77
ZGA048	84	80	79	74	70	67	63	80
ZGA060	86	82	82	78	74	68	65	83
ZGA072	88	85	84	79	72	66	64	84
ZGB036	81	78	77	72	68	66	61	77
ZGB048	84	80	79	74	70	67	63	80
ZGB060	80	76	76	73	68	66	64	78

¹ Sound Rating Number according to ANSI/AHRI Standard 270-2008. "SRN" is the overall A-Weighted Sound Power Level, (LWA), dB (100 Hz to 10,000 Hz).

OPTIONS / ACCESSORIES

		Shipping Weights	
		kg	lbs.
ECONOMIZER			
Economizer			
Economizer, Includes Outdoor Air Hood and Barometric Relief Dampers with Hood	Downflow	34	75
	Horizontal	46	102
OUTDOOR AIR			
Outdoor Air Dampers			
Motorized		18	39
Manual		13	29
POWER EXHAUST			
Standard Static	Downflow	24	54
	Horizontal	19	41
GAS HEAT			
	Medium Heat (adder over standard heat)	4	8
	High Heat (adder over standard heat)	9	19
ROOF CURBS			
Hybrid Roof Curbs, Downflow			
203 mm height		29	63
356 mm height		38	83
457 mm height		42	93
610 mm height		51	113
CEILING DIFFUSERS			
Step-Down	RTD9-65S	36	80
	RTD11-95S	54	118
Flush	FD9-65S	36	80
	FD11-95S	54	118

DIMENSIONS - UNIT - MM (INCHES) - ZGA

Model No.	CORNER WEIGHTS																CENTER OF GRAVITY							
	AA				BB				CC				DD				EE				FF			
	Base		Max.		Base		Max.		Base		Max.		Base		Max.		Base		Max.		Base		Max.	
	kg	lbs.	kg	lbs.	kg	lbs.	kg	lbs.	kg	lbs.	kg	lbs.	kg	lbs.	kg	lbs.	mm	in.	mm	in.	mm	in.	mm	in.
036	56	124	65	142	52	115	66	146	53	117	58	129	58	127	57	125	1003	39.5	953	37.5	591	23.25	635	25
048	58	128	68	149	54	118	69	153	55	121	61	135	59	131	60	131	1003	39.5	953	37.5	591	23.25	635	25
060	62	136	72	158	57	126	74	162	58	129	65	143	63	139	63	139	1003	39.5	953	37.5	591	23.25	635	25
072	69	153	77	170	69	153	77	170	76	167	84	186	76	167	84	186	965	38	914	36	572	22.5	610	24

Base Unit - The unit with NO OPTIONS.

Max. Unit - The unit with ALL OPTIONS Installed. (Economizer, high heat, largest blower motor, etc.).

BOTTOM POWER ENTRY

Holes required for Optional Bottom Power Entry Kit

	Threaded Conduit Fittings (Provided in Kit)	Wire Use	Hole Diameter Required in Unit Base (Max.)
A	1/2	ACC	23 (7/8)
B	1/2	24V	23 (7/8)
C	3/4	POWER	29 (1-1/8)

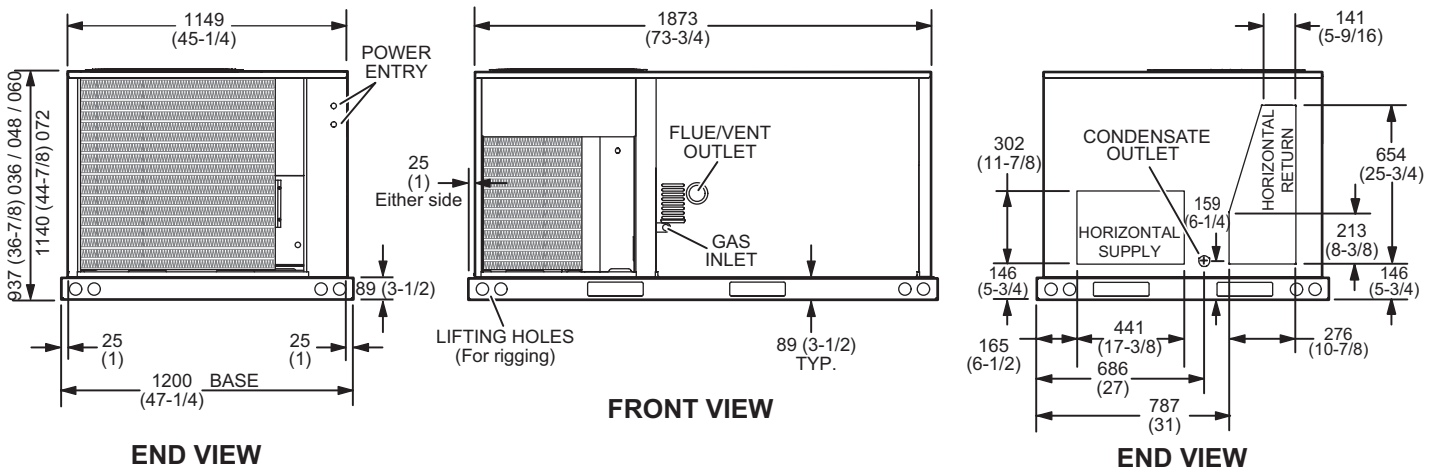
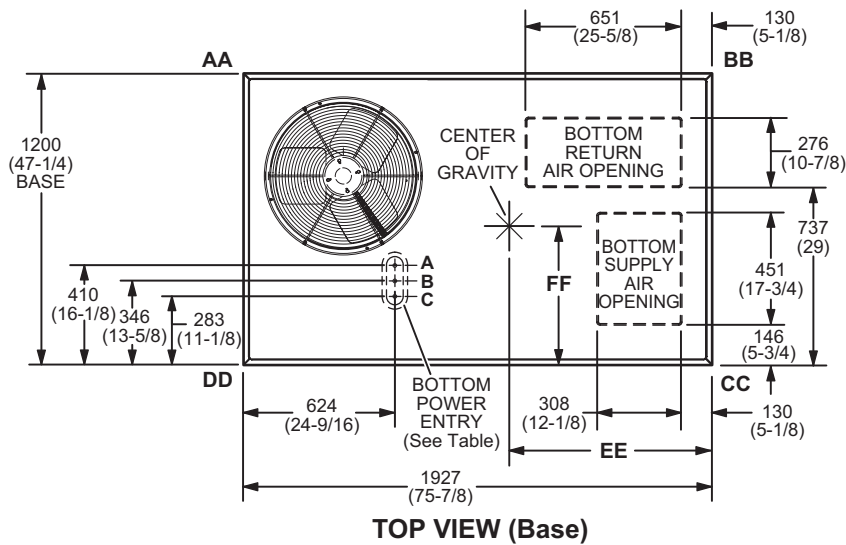

DIMENSIONS - UNIT - MM (INCHES) - ZGB

Model No.	CORNER WEIGHTS														CENTER OF GRAVITY									
	AA		BB		CC		DD		EE		FF		Base		Max.		Base		Max.					
	kg	lbs.	kg	lbs.	kg	lbs.	kg	lbs.	kg	lbs.	mm	in.	mm	in.	mm	in.	mm	in.	mm	in.				
036	58	129	67	147	56	124	64	141	60	133	68	150	63	138	70	156	984	39	933	37	578	23	622	25
048	60	132	68	149	57	126	65	143	61	135	69	152	64	140	72	159	984	39	933	37	578	23	622	25
060	73	162	83	182	66	146	74	164	61	134	68	151	68	149	76	167	1016	40	965	38	622	25	660	26
074	69	153	77	170	69	153	77	170	76	167	84	186	76	167	84	186	965	38	914	36	572	22.5	610	24

Base Unit - The unit with NO OPTIONS.

Max. Unit - The unit with ALL OPTIONS Installed. (Economizer, high heat, largest blower motor, etc.).

BOTTOM POWER ENTRY

Holes required for Optional Bottom Power Entry Kit

	Threaded Conduit Fittings (Provided in Kit)	Wire Use	Hole Diameter Required in Unit Base (Max.)
A	1/2	ACC	23 (7/8)
B	1/2	24V	23 (7/8)
C	3/4	POWER	29 (1-1/8)

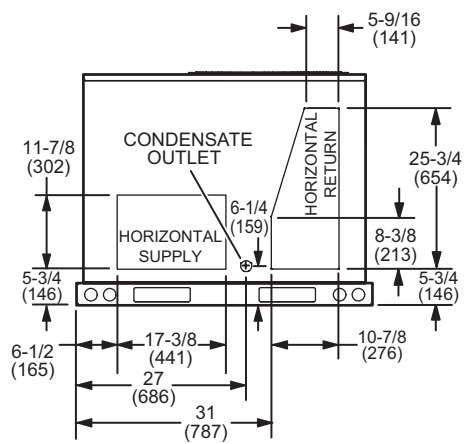
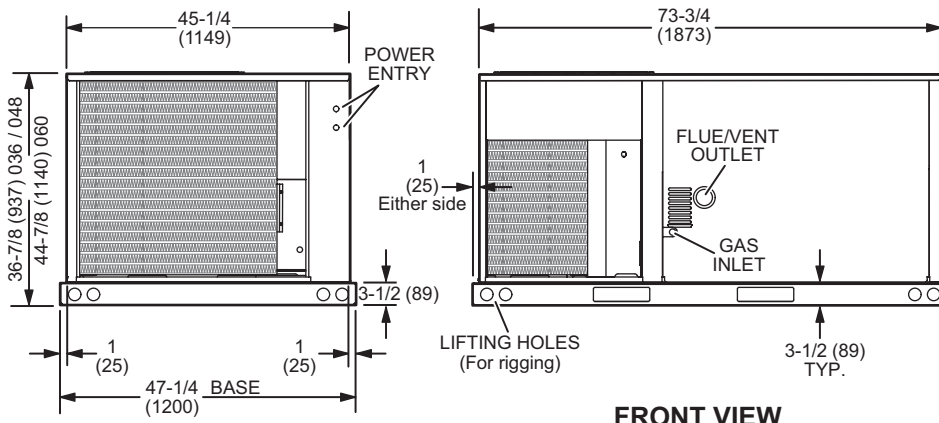
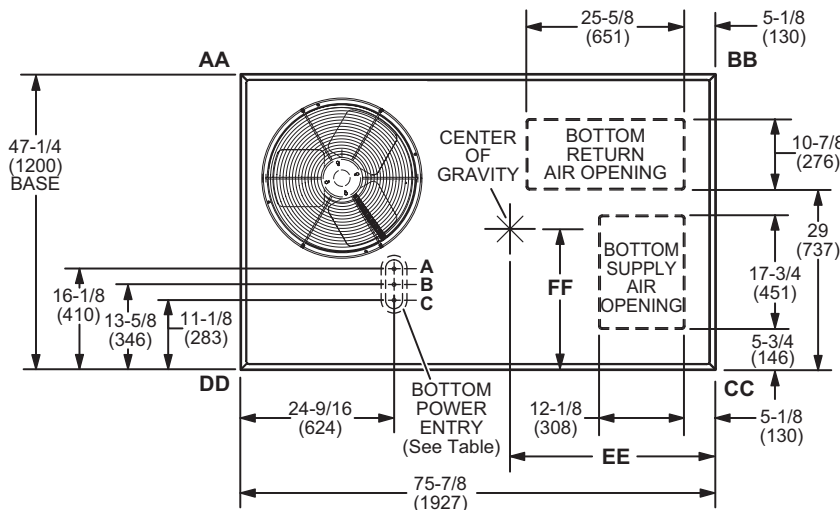

DIMENSIONS - ACCESSORIES - MM (INCHES)

**OUTDOOR AIR HOOD DETAIL FOR OPTIONAL ECONOMIZER
(Downflow Applications)**

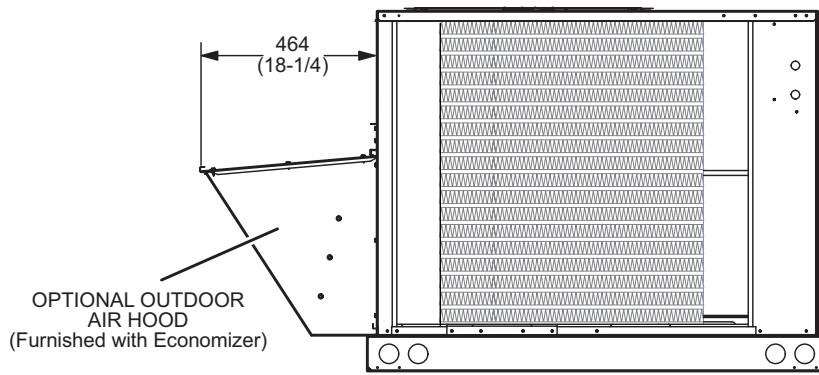

SIDE VIEW

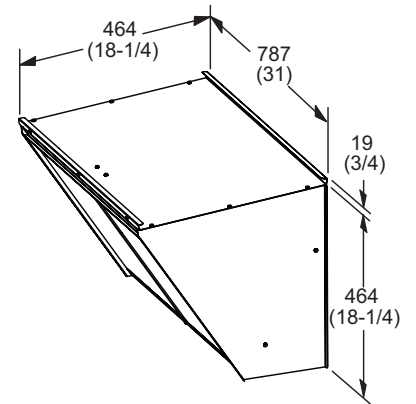

OUTDOOR AIR DAMPER HOOD DETAIL (Downflow or Horizontal Applications)

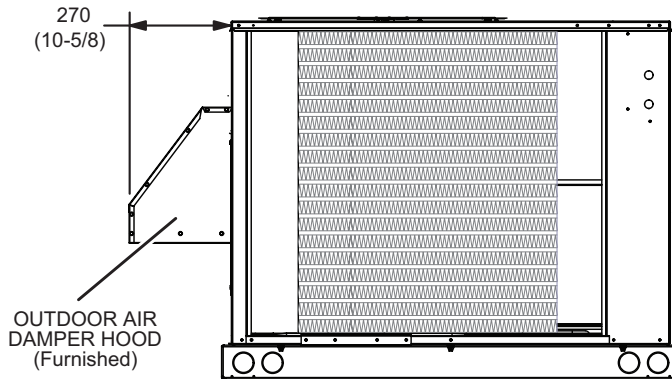

SIDE VIEW

MANUAL OUTDOOR AIR HOOD

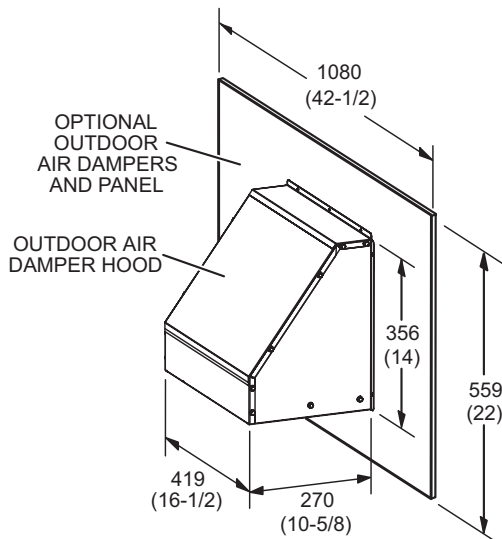

MOTORIZED OUTDOOR AIR HOOD

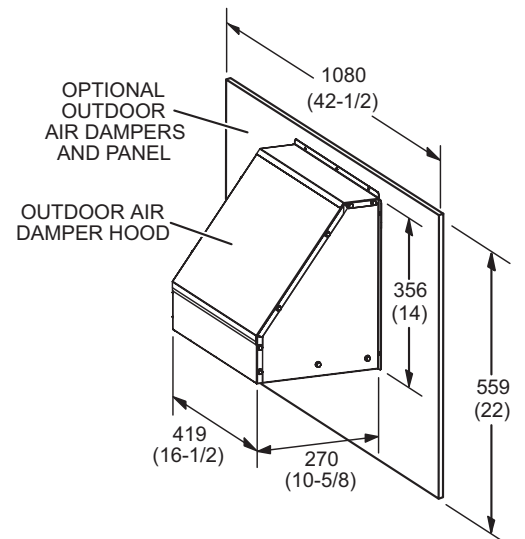

DIMENSIONS - ACCESSORIES - MM (INCHES)

OUTDOOR AIR HOOD DETAIL WITH OPTIONAL ECONOMIZER AND BAROMETRIC RELIEF DAMPERS (Horizontal Applications)

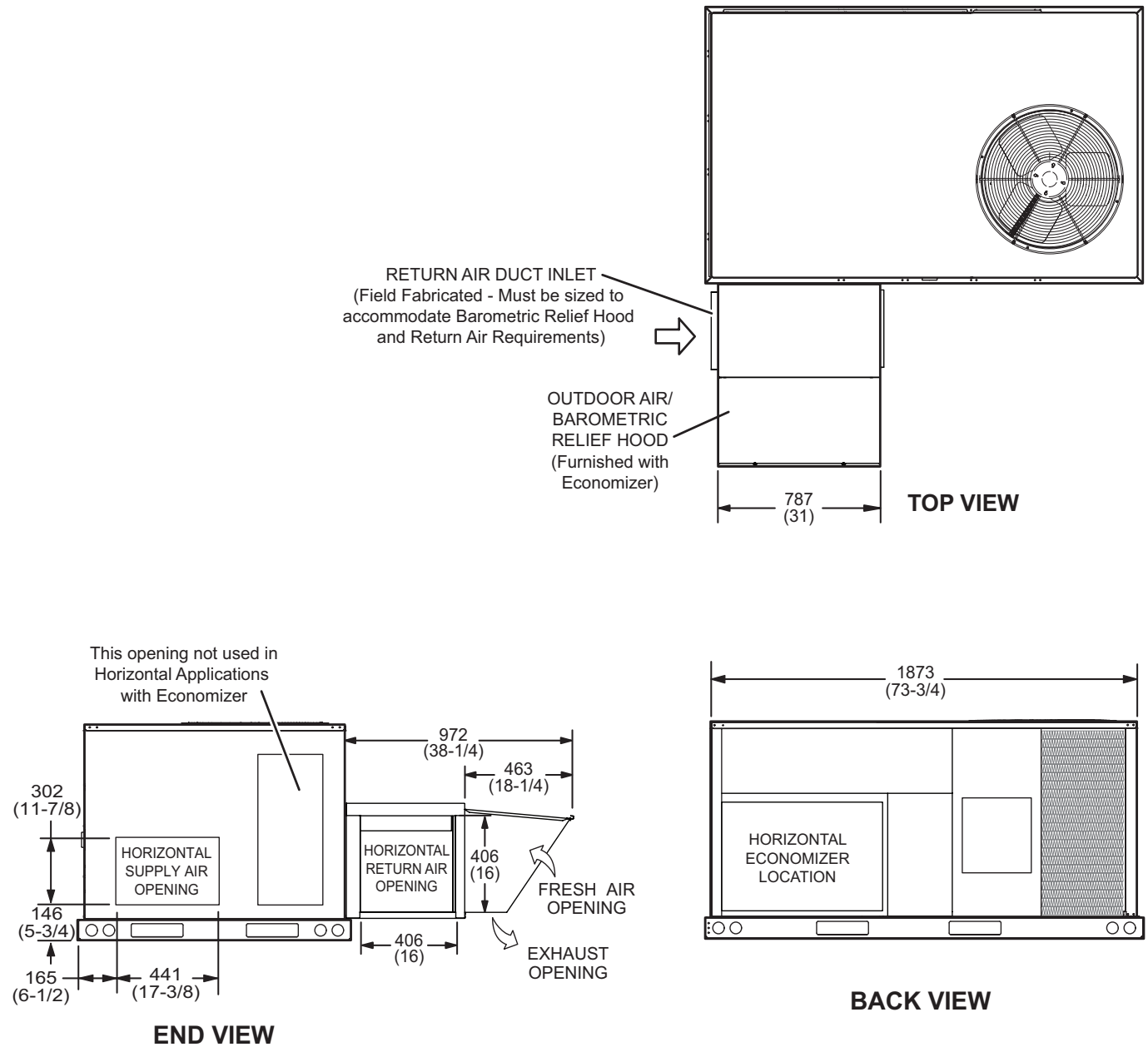

Note - Return Air Duct and Transition must be supported.

DIMENSIONS - ACCESSORIES - MM (INCHES)

HYBRID ROOF CURBS - DOUBLE DUCT OPENING

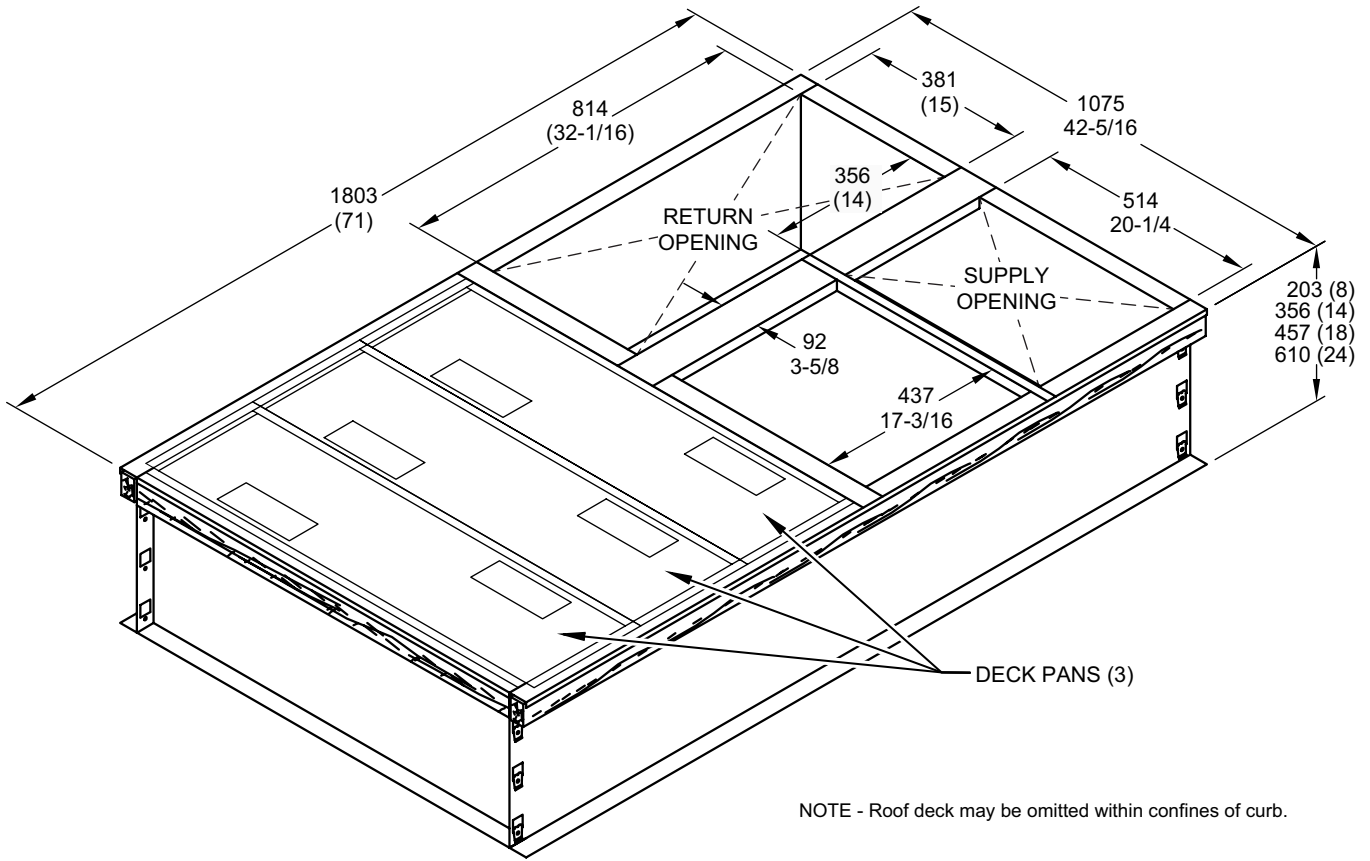

NOTE - Roof deck may be omitted within confines of curb.

TYPICAL FLASHING DETAIL FOR ROOF CURB

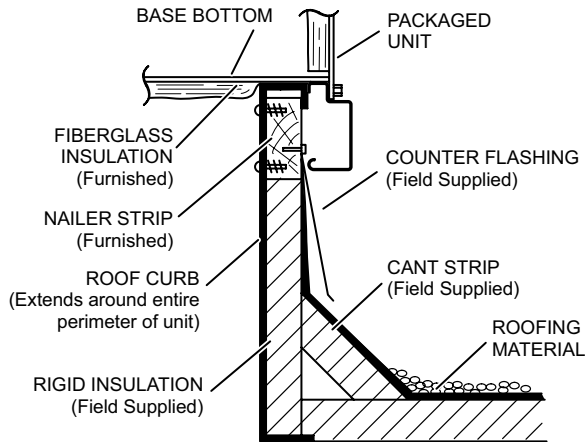

DETAIL ROOF CURB

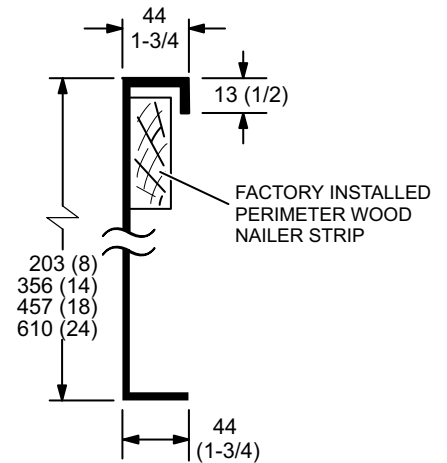

DIMENSIONS - ACCESSORIES - MM (INCHES)

COMBINATION CEILING SUPPLY AND RETURN DIFFUSERS

STEP-DOWN CEILING DIFFUSER

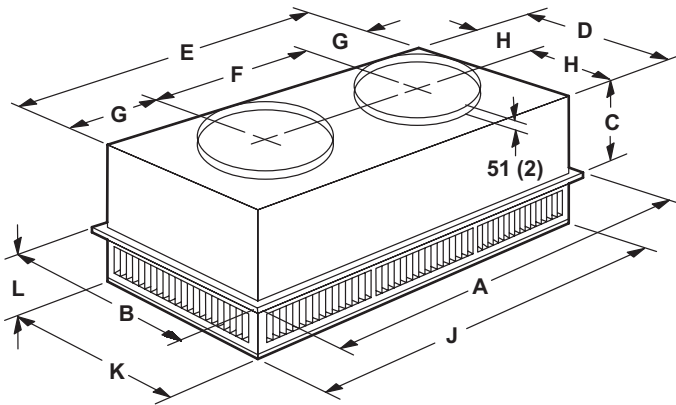

FLUSH CEILING DIFFUSER

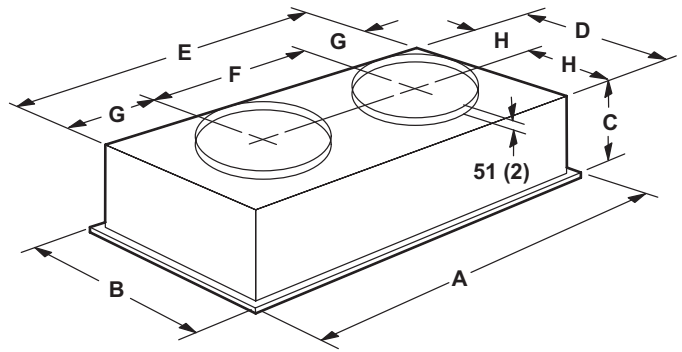

Model Number		RTD9-65S	RTD11-95S
A	mm	1159	1159
	in.	47-5/8	47-5/8
B	mm	600	752
	in.	23-5/8	29-5/8
C	mm	289	365
	in.	11-3/8	14-3/8
D	mm	546	699
	in.	21-1/2	27-1/2
E	mm	1156	1158
	in.	45-1/2	45-1/2
F	mm	572	572
	in.	22-1/2	22-1/2
G	mm	292	292
	in.	11-1/2	11-1/2
H	mm	273	349
	in.	10-3/4	13-3/4
J	mm	1156	1156
	in.	45-1/2	45-1/2
K	mm	546	699
	in.	21-1/2	27-1/2
L	mm	181	206
	in.	7-1/8	8-1/8
Duct Size	mm	457 round	508 round
	in.	18 round	20 round

Model Number		FD9-65S	FD11-95S
A	mm	1159	1159
	in.	47-5/8	47-5/8
B	mm	600	752
	in.	23-5/8	29-5/8
C	mm	343	422
	in.	13-1/2	16-5/8
D	mm	533	686
	in.	21	27
E	mm	1143	1143
	in.	45	45
F	mm	572	572
	in.	22-1/2	22-1/2
G	mm	286	286
	in.	11-1/4	11-1/4
H	mm	267	343
	in.	10-1/2	13-1/2
Duct Size	mm	457 round	20 round
	in.	18 round	508 round

REVISIONS

Sections	Description of Change
Optional Accessories	Updated model and catalog numbers for manual and motorized Outdoor Air Dampers with Outdoor Air Hood.
Dimensions	Added new Outdoor Air Damper Hood drawing for Motorized Dampers.



Visit us at www.allied-commercial.com

For the latest technical information, visit us at www.allied-commercial.com

Contact us at 1-800-738-4000

NOTE - Due to Allied Commercial ongoing commitment to quality, Specifications, Ratings and Dimensions subject to change without notice and without incurring liability. Improper installation, adjustment, alteration, service or maintenance can cause property damage or personal injury. Installation and service must be performed by a qualified installer and servicing agency.

©2017 Allied Air Enterprises LLC, a Lennox International Inc. Company