

E.2 SERIES CIRCULATORS

E9.2/E9.2B | SUBMITTAL

File No: 10.592
 Date: JUNE 25, 2012
 Supersedes: 10.592
 Date: MARCH 15, 2012

Job: _____ Representative: _____
 _____ Order no.: _____ Date: _____
 Engineer: _____ Submitted by: _____ Date: _____
 Contractor: _____ Approved by: _____ Date: _____

QUANTITY	TAG NO.	PART NUMBER	FLOW (USgpm)	HEAD (FEET)	VOLTAGE	PHASE	COMMENTS

TECHNICAL DATA

Flow range: 0 to 38.0 USgpm (0 to 2.4 L/s)
Head range: 0 to 42.4 feet (0 to 12.9 m)
Max/Min fluid temp: 230°F/40°F (110°C/4°C)
Max. working pressure: 150 psi (1034 kPa)

MATERIALS OF CONSTRUCTION

Pump body: Cast iron (closed systems)
 Bronze (lead free for open systems)

Face plate: Stainless steel **Shaft:** Stainless steel
Impeller: 30% Glass-filled noryl **Volute gasket:** EPDM
Bearings: Permanently lubricated stainless steel
Seal: Silicon carbide enviroseal c/w viton elastomer

PART NUMBER

	120V	240V
E9.2	182202-659	182202-647
E9.2B	182202-660	182202-648

E9.2/E9.2B ACCESSORIES

- ¾" Flange kits
- 1" Flange kits
- 1¼" Flange kits
- 1½" Flange kits
- Timer
- Aquastat
- Spool pieces

MOTOR DATA

Voltage	120V	208V	240V
Full load amp draw	2.0A	1.0A	1.0A

Nominal power: ¼ hp (125W) **Frequency:** 60 Hz
Motor type: Two pole, Single phase **Speed:** 3250 rpm

MOUNTING ORIENTATION FOR INDOOR USE ONLY

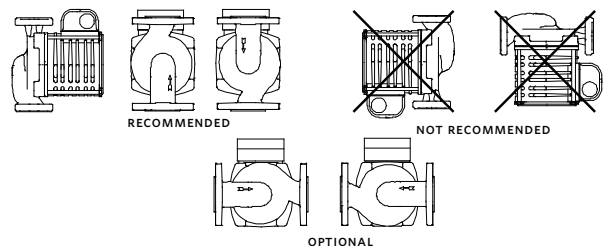

PERFORMANCE CURVE

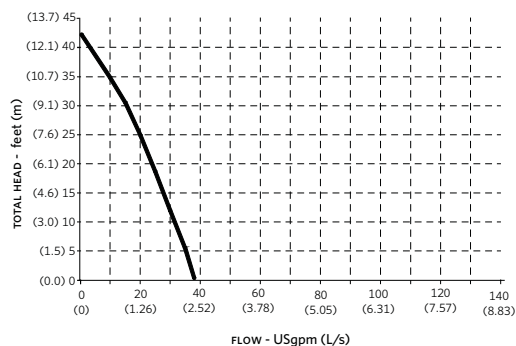

Performance curves are for reference only. Confirm current performance data with Armstrong ACE ONLINE selection software.

DIMENSIONS inches (mm)								SHIP. WEIGHT	
MODEL	BODY	A	B	C	D	E	F	CONNECTION TYPE & SIZE	lbs (kgs)
E9.2	Cast iron	7.10 (180)	6.40 (164)	5.50 (140)	3.80 (97)	3.20 (81)	4.20 (107)	1.25" diameter 2-bolt flanges	13.1 (5.94)
E9.2B	Bronze	7.10 (180)	6.40 (164)	5.50 (140)	3.80 (97)	3.20 (81)	4.20 (107)	1.25" diameter 2-bolt flanges	13.3 (6.03)

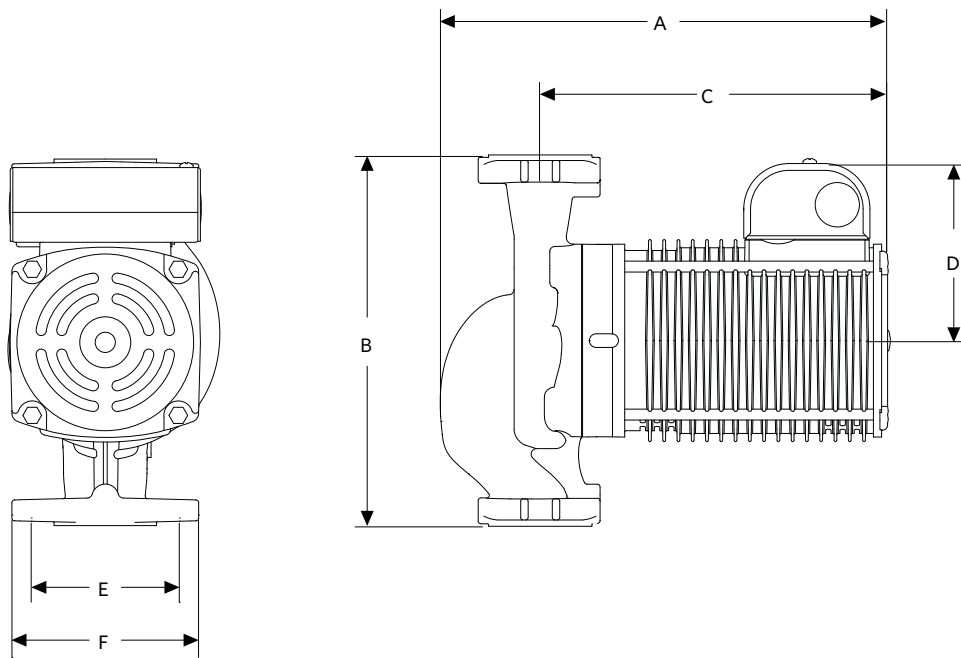

TORONTO

+416 755 2291

BUFFALO

+716 693 8813

BIRMINGHAM

+44 (0) 8444 145 145

MANCHESTER

+44 (0) 8444 145 145

BANGALORE

+91 (0) 80 4906 3555

SHANGHAI

+86 21 3756 6696