

MAXITROL

Gas Appliance Regulators 210 Series

210D, 210E, 210G & 210J*

Maximum Inlet Pressure: 10 psi

Emergency Exposure Limits: 25 psi

Ambient Temperature Limits: - 40° to 200° F

Gases: Natural, manufactured, mixed, liquified petroleum or LP gas-air mixture.

Mounting: upright only.

Note: All Maxitrol gas appliance regulators should be installed and operated in accordance with Maxitrol's "Safety Warning" Bulletin.

The 210 series is a lock-up type regulator and complies with codes using this specification.

The 210 series has been designed for maximum control function in an easy to use package. The series is intended for use with gas-fired boilers, steam generators, industrial furnaces, ovens, and similar high demand equipment.

The balanced valve design eliminates the inlet pressure effect acting on the valve. Regulating stability is improved and hunting tendencies reduced by the use of dampening mechanisms in both the breather outlet and sensing tube. You get precise regulation over a broad range of pressures and flow rates with the 210 series, including a "zero governor" application.

Housings are of high strength aluminum alloy and are reinforced with webs for maximum strength. The 210J model is of cast iron and steel construction with 125 pound flange connections. Internal parts are cast or machined from corrosion resistant metals or electroplated.

Diaphragms are of the finest synthetic coated fabrics.

*Not CSA approved

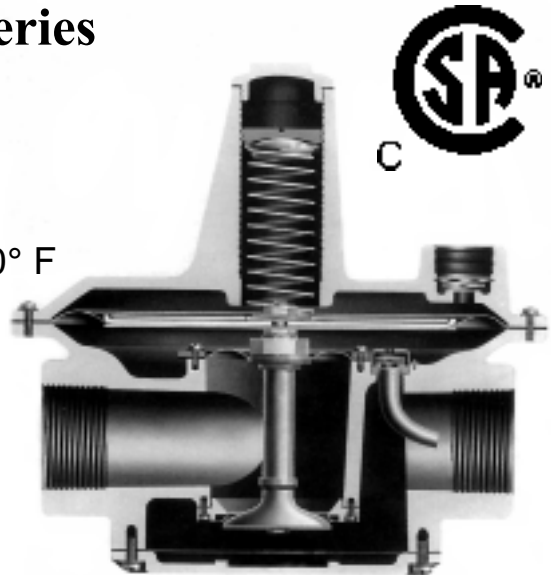

balanced valve design

When selecting pipe size, make sure regulator is not more than one size smaller or larger than manifold pipe size. Gas flow must be oriented to arrow on the bottom casting. At exposures to maximum emergency levels, the regulator will suffer no internal damage, but it may provide accurate regulation. See Maxitrol's "Spring Chart" for complete selection of spring ranges on all models.

Convenient tap locations are provided for downstream sensing, cross connections, and differential control. Four locations can be tapped and plugged for measuring pressure.

The 210D, E, and G may be ordered with remote sensing. The internal sensing tube is omitted and external sensing taps are provided. Add suffix letter "R" to model numbers when ordering.

Vertical vent tapped - 1/2" NPT on 210D, 3/4" on 210E, G, and J.

The 210 series is designed to operate as a "zero governor" in the normal upright position - See Bulletin MS2043.

Specifications

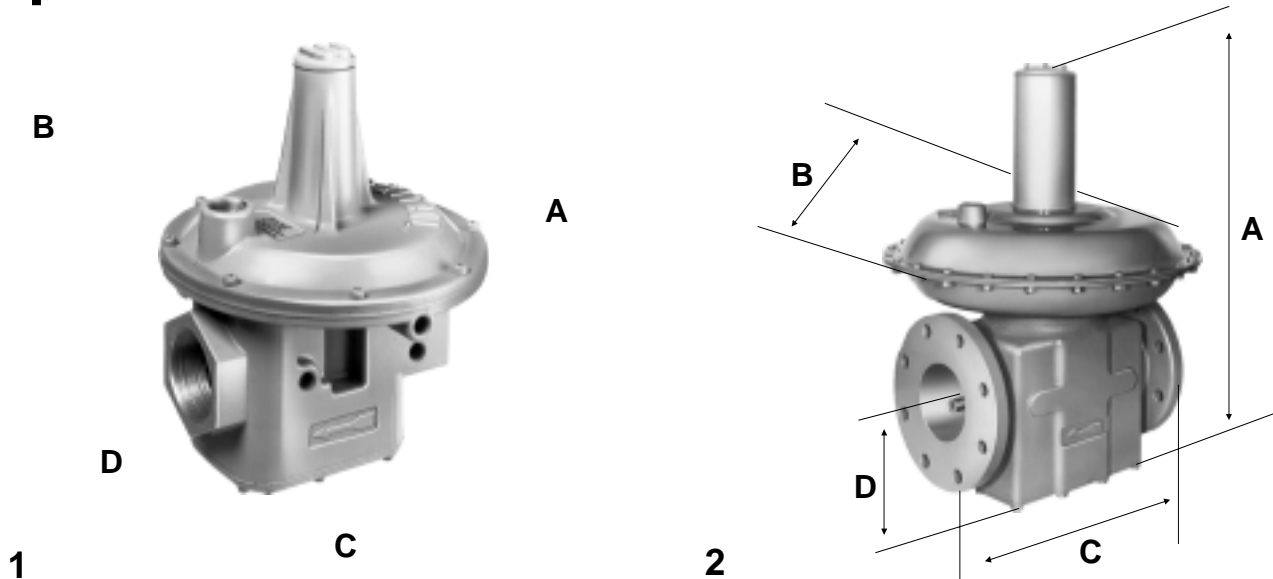

DIMENSIONS — in inches

Model and Illustration Number		Swing Radius	Call-Outs			
			A	B	C	D
210D	1	5 ^{7/16}	9	7	6	2 ^{3/8}
210E	1	8 ^{5/16}	11 ^{1/4}	9 ^{1/8}	8	2 ^{15/16}
210G	1	11 ^{7/8}	16 ^{1/2}	13 ^{1/2}	10 ^{3/8}	4 ^{9/16}
210J	2	18	24 ^{1/4}	18	13 ^{3/4}	5 ^{7/16}

SPRING SELECTION CHART — in inches

Model and Illustration Number		Other Springs Available									
210D	3.0" to 6.0"	1.0 - 3.5	2.0 - 5.0	3.0 - 8.0	4.0 - 8.0	4.0 - 12	5.0 - 12	5.0 - 15	10 - 22	15 - 30	20 - 42
210E	3.0" to 6.0"	1.0 - 3.5	2.0 - 5.0	3.0 - 8.0	4.0 - 8.0	4.0 - 12	5.0 - 12	5.0 - 15	10 - 22	15 - 30	20 - 42
210G	3.0" to 6.0"	1.0 - 3.5	2.0 - 5.0	3.0 - 8.0	4.0 - 8.0	4.0 - 12	5.0 - 12	5.0 - 15	10 - 22	15 - 30	20 - 42
210J	3.0" to 6.0"	—	2.0 - 5.0	3.0 - 8.0	—	4.0 - 12	5.0 - 12	—	10 - 22	15 - 30	20 - 42

CAPACITIES — expressed in ft³/h @ 0.64 sp gr gas

Model Number and Pipe Size		0.1	0.3	0.5	1.0	3.0	5.0	7.0	1/2 psi	3/4 psi	1 psi	1.5 psi
210D	1 x 1	—	—	—	900	1600	2000	2400	3300	4100	4750	5800
	1 ^{1/4} x 1 ^{1/4}	—	—	—	1100	1900	2500	2900	4100	5000	5850	7150
	1 ^{1/2} x 1 ^{1/2}	—	—	—	1200	2100	2700	3200	4500	5500	6350	7750
210E	1 ^{1/2} x 1 ^{1/2}	—	1050	1350	1915	3315	4280	5065	7125	8725	10075	12340
	2 x 2	—	1210	1560	2210	3825	4940	5845	8225	10070	11630	14245
210G	2 ^{1/2} x 2 ^{1/2}	1410	2450	3160	4470	7740	9995	11825	16635	20375	23525	28810
	3 x 3	1555	2695	3475	4920	8520	11000	13020	18310	22425	25890	31710
210J	4 x 4	2700	4700	6000	8600	15000	19000	23000	32000	40000	45000	55700

MAXITROL