



# 40003916-500 Series Replacement Powerhead

## INSTALLATION INSTRUCTIONS

### APPLICATION

The new 40003916-500 series actuators are field replacements for the powerheads on V8043 series motorized zone valves.

These new powerheads are to be used with the new 5000 series valves. They feature a “Quick Fit” button at the side that speeds up installation and service by allowing the actuator to snap onto a 5000 series valve.

The 500 series actuators are also backward compatible with the V8043 1000 series zone valves. When installing a 500 series actuator on a 1000 series valve body, it is necessary to use screws to secure the two together.

### INSTALLATION

#### CAUTION

Normally it is not necessary to remove the powerhead from the valve body during installation. The valve must be disassembled with the water flow arrow pointing away from the manual opening or lever slot.

NOTE: It is not necessary to drain the hydronic system if the valve body assembly remains in the pipe line.



40003916-521



40003916-526



40003916-548

#### Removing a New-Style Actuator from a New-Style Valve Body (See Fig. 1.)

1. Switch power supply OFF. Disconnect electrical leads carefully, noting the position and color of each lead. (Tip: label the wires indicating where they belong before disconnecting them.)
2. Place the manual lever in the MAN. OPEN position.
3. Remove the actuator by *fully* depressing spring release button and lift it straight off the body.

NOTE: The retaining spring presses on the outside of the bearing hub, but this does not lock the actuator in place. It is easy to remove the powerhead when the “Quick Fit” button is fully depressed.



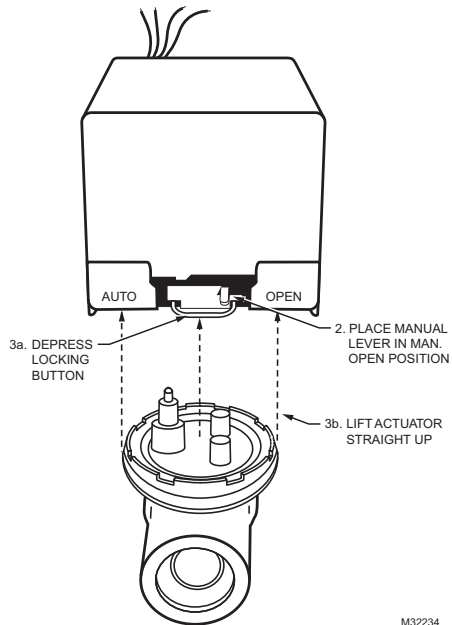

M32234

**Fig. 1. Removing Actuator from Valve Body.**

**Installing a New-Style Actuator on a New-Style Valve Body**

1. Place the manual lever in the MAN. OPEN position.
2. Align the parallel flat surfaces on double-D shaft of valve body with notch on side of body (i.e. 90° to water flow.) This makes the attachment of the actuator easier. (See Fig. 2)
3. Line up motor coupling to the parallel flat surfaces in double-D shaft of body and fit the actuator onto the valve body. Ensure shaft seats correctly. (See Fig. 3.)
4. Snap actuator onto body by pressing down.
5. Reconnect the wiring. (Wiring connections may be made either before or after the actuator is installed on the valve body.)

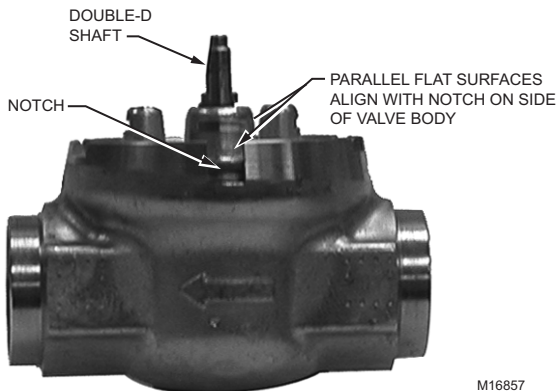

M16857

**Fig. 2. Shaft Position.**

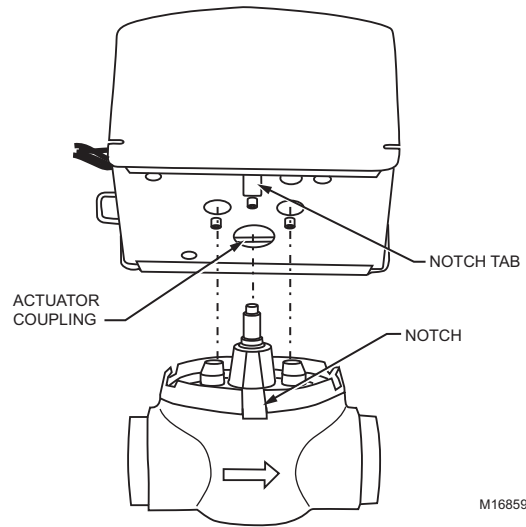

M16859

**Fig. 3. Installing Actuator.**

**INSTALLATION**

**⚠ CAUTION**

Normally it is not necessary to remove the powerhead from the valve body during installation. The valve must be disassembled with the water flow arrow pointing away from the manual opening or lever slot.

NOTE: It is not necessary to drain the hydronic system if the valve body assembly remains in the pipe line.

**Removing an Old-Style Actuator from an Old-Style Valve Body**

1. Switch power supply OFF. Disconnect electrical leads carefully, noting the position and color of each lead. (Tip: label the wires indicating where they belong before disconnecting them.)
2. Place the manual lever in the MAN. OPEN position. (See Fig. 4.)
3. Remove the covering over the actuator. (See Fig. 5.)
4. Remove the two screws that secure the powerhead to the valve body. (See Fig. 6.)
5. Lift the actuator off the valve body.

**Installing a New-Style Actuator on an Old-Style Valve Body**

1. Place the manual lever in the MAN. OPEN position.
2. Align the actuator coupling with the shaft. (See Fig. 7.)
3. Snap actuator onto valve body by pressing down. Ensure that the shaft seats correctly.
4. Secure the actuator on either side with the two screws provided.
5. Replace the cover over the actuator.
6. Reconnect the wiring. (Wiring connections may be made either before or after the actuator is installed on the valve body.)

NOTE: The manual lever may be released manually, but it is also automatically released when the valves are operated electrically.

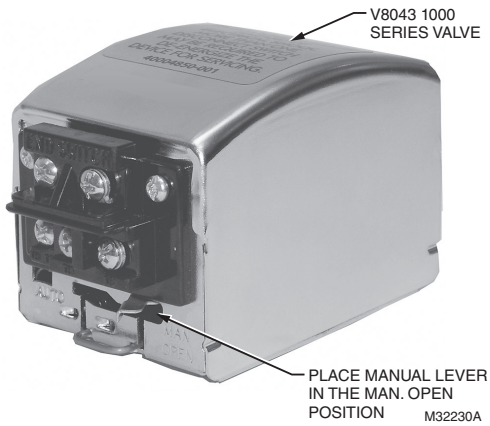

**Fig. 4. Lever Position.**

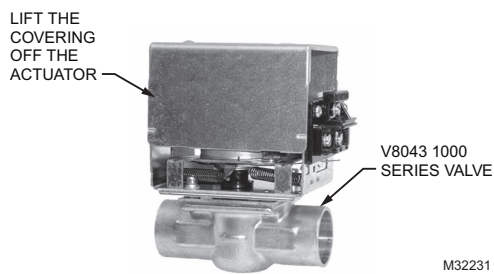

**Fig. 5. Removing the Covering.**

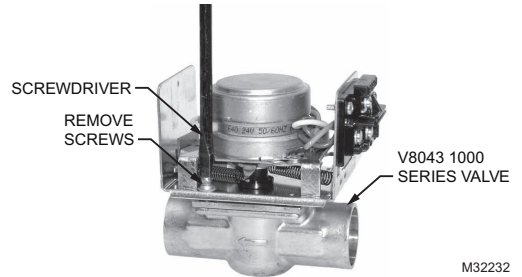

**Fig. 6. Removing the Old Actuator from Valve Body.**

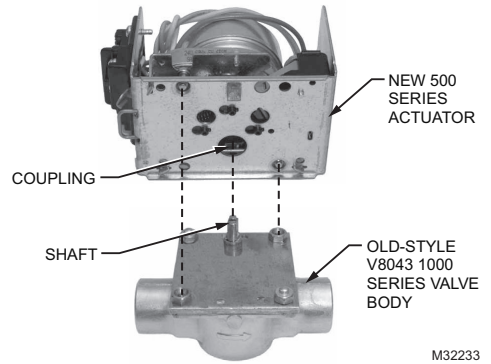

**Fig. 7. Installing New 5000 Series Actuator on a V8043 1000 Series Body.**

40003916-500 SERIES REPLACEMENT POWERHEAD



[www.resideo.com](http://www.resideo.com)

Resideo Technologies, Inc.  
1985 Douglas Drive North, Golden Valley, MN 55422  
1-800-468-1502  
95C-10944-04 M.S. Rev. 04-20 | Printed in United States

© 2020 Resideo Technologies, Inc. All rights reserved.  
The Honeywell Home trademark is used under license from Honeywell International, Inc. This product is manufactured by Resideo Technologies, Inc. and its affiliates.