

AIR CONDITIONER

Duct type

SERVICE MANUAL

INDOOR

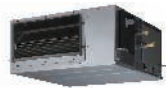

ARUH12LUAS

OUTDOOR



AOUH12LUAS1

Notices:

- Product specifications and design are subject to change without notice for future improvement.
- For further details, please check with our authorized dealer.

Trademarks

FGLair™ is trademark of Fujitsu General Limited in the United States, other countries or both.

Google Play™ is trademark of Google LLC.

App Store® is a service mark of Apple Inc., registered in the U.S. and other countries.

CONTENTS

1. GENERAL INFORMATION

2. TECHNICAL DATA AND PARTS LIST

3. TROUBLESHOOTING

4. CONTROL AND FUNCTIONS

5. FIELD WORKING

1. GENERAL INFORMATION

CONTENTS

1. GENERAL INFORMATION

1. Specifications	01-1
1-1. Indoor unit	01-1
1-2. Outdoor unit.....	01-3
2. Dimensions	01-4
2-1. Indoor unit	01-4
2-2. Outdoor unit.....	01-7

1. Specifications

1-1. Indoor unit

Type				Duct			
				Inverter, Heat pump			
Model name				ARUH12LUAS			
Power supply				208/230 V~ 60 Hz			
Power supply intake				Outdoor unit			
Available voltage range				187—253 V			
Capacity	Cooling	Rated	kW	3.52			
			Btu/h	12,000			
		Min.—Max.	kW	0.9—4.0			
			Btu/h	3,100—13,600			
	Heating	47°FDB (Outdoor temp.)	Rated	kW	4.69		
				Btu/h	16,000		
			Min.—Max.	kW	0.99—5.70		
				Btu/h	3,400—19,400		
		17°FDB (Outdoor temp.)*1	Rated	kW	3.08		
				Btu/h	10,500		
			Max.	kW	5.18		
				Btu/h	17,600		
5°FDB (Outdoor temp.)*2	Rated	kW	4.54				
		Btu/h	15,500				
	Max.	kW	4.69				
		Btu/h	16,000				
Input power	Cooling	Rated	kW	0.96			
				Min.—Max.	0.12—1.45		
		Heating	47°FDB (Outdoor temp.)	Rated	kW	1.25	
						Min.—Max.	0.18—1.84
	17°FDB (Outdoor temp.)*1		Rated	kW	1.02		
					Max.	1.97	
	5°FDB (Outdoor temp.)*2		Rated	kW	2.25		
					Max.	2.25	
	Fan			W	HIGH		
					61		
					MED		
					34		
				LOW			
				24			
				QUIET			
				16			
				4.3			
Current		Cooling	Rated	A	5.5		
		Heating			3.66		
EER2		Cooling		kW/kW	12.5		
				Btu/hW	3.76		
COP2		Heating		kW/kW	12.8		
				Btu/hW	19.1		
SEER2		Cooling		Btu/hW	10.5		
HSPF2		Heating			97.1		
Power factor		Cooling		%	98.8		
		Heating			1.5 (0.7)		
Moisture removal				pints/h (L/h)	9.8		
Maximum operating current*3		Cooling		A	11.3		
		Heating			500 (850)		
Fan	Airflow rate	Cooling	HIGH	CFM (m ³ /h)	400 (680)		
			MED		347 (590)		
			LOW		300 (510)		
			QUIET		500 (850)		
		Heating	HIGH	400 (680)			
			MED	347 (590)			
			LOW	300 (510)			
			QUIET	300 (510)			
	Type × Qty	Sirocco fan × 1					
	Motor output	W					
					154		
	Static pressure range				inWG (Pa)	0.12 to 0.80 (30 to 200)	
Sound pressure level*4	Cooling		HIGH	dB (A)	35		
			MED		30		
			LOW		27		
			QUIET		24		
	Heating		HIGH	35			
			MED	30			
			LOW	27			
			QUIET	24			
			Dimensions (H × W × D)		in (mm)	16-9/16 × 18-1/16 × 1-9/16 (420 × 458 × 39.9)	
			Fin pitch		FPI	18	
Rows × Stages			3 × 20				
Pipe type			Copper				
Fin type			Aluminum				
			Hydrophilic coating				
Enclosure		Material	Steel				
		Color	—				
Dimensions (H × W × D)	Net		in (mm)	11-13/16 × 27-9/16 × 27-9/16 (300 × 700 × 700)			
	Gross			15-3/4 × 36-15/16 × 34-7/16 (400 × 938 × 875)			
Weight	Net		lb (kg)	66 (30)			
	Gross			82 (37)			
Connection pipe	Size	Liquid	in (mm)	Ø1/4 (Ø6.35)			
		Gas		Ø3/8 (Ø9.52)			
Method		Flare					
Material		PVC					
Drain hose		Tip diameter		in (mm)			
				Ø13/16 (20.7) (I.D.), Ø1-1/16 (26.6) (O.D.)			

Type			Duct	
			Inverter, Heat pump	
Model name			ARUH12LUAS	
Operation range	Cooling	*F (°C)	64 to 90 (18 to 32)	
	Heating	%RH	80 or less	
		*F (°C)	60 to 86 (16 to 30)	
NOTES:				
<ul style="list-style-type: none"> Specifications are based on the following conditions: <ul style="list-style-type: none"> Cooling: Indoor temperature of 80°FDB/67°FWB (26.67°CDB/19.44°CWB), and outdoor temperature of 95°FDB/75°FWB (35°CDB/23.9°CWB). Heating: Indoor temperature of 70°FDB/60°FWB (21.11°CDB/15.56°CWB), and outdoor temperature of 47°FDB/43°FWB (8.33°CDB/6.11°CWB). *1: Heating (17°F): Indoor temperature of 70°FDB/60°FWB (21.11°CDB/15.56°CWB), and outdoor temperature of 17°FDB/15°FWB (-8.33°CDB/-9.44°CWB). *2: Heating (5°F): Indoor temperature of 70°FDB/60°FWB (21.11°CDB/15.56°CWB), and outdoor temperature of 5°FDB/4°FWB (-15.0°CDB/-15.56°CWB). Test conditions are based on AHRI 210/240 2023. Pipe length: 24 ft 7 in (7.5 m), Height difference: 0 ft (0 m). (Between outdoor unit and indoor unit.) Standard static pressure: 0.18 inWG (45 Pa) Protective function might work when using it outside the operation range. *3: Maximum current: <ul style="list-style-type: none"> The maximum value when operated within the operation range. The total current of indoor unit and outdoor unit. *4: Sound pressure level: <ul style="list-style-type: none"> Measured values in manufacturer's anechoic chamber. Because of the surrounding sound environment, the sound levels measured in actual installation conditions might be higher than the specified values here. 				

M condition					
Model name			ARUH12LUAS		
Capacity	Cooling	Rated	kW	3.52	
			Btu/h	12,000	
		Min.—Max.	kW	0.9—4.0	
			Btu/h	3,100—13,600	
	Heating	47°FDB (Outdoor temp.)	Rated	kW	4.69
			Btu/h	16,000	
			Min.—Max.	kW	0.99—5.70
		17°FDB (Outdoor temp.)*	Btu/h	3,400—19,400	
			Rated	kW	3.08
			Btu/h	10,500	
Max.	kW	5.18			
	Btu/h	17,600			
Input power	Cooling	Rated	kW	0.89	
		Min.—Max.	kW	0.12—1.45	
	Heating	47°FDB (Outdoor temp.)	Rated	kW	1.20
			Min.—Max.	kW	0.18—1.84
		17°FDB (Outdoor temp.)*	Rated	kW	1.02
			Max.	kW	1.97
	Fan	HIGH	W	61	
		MED	W	34	
		LOW	W	24	
		QUIET	W	16	
Current	Cooling	Rated	A	4.0	
	Heating	Rated	A	5.3	
EER	Cooling	kW/kW		3.93	
		Btu/hW		13.4	
COP	Heating	kW/kW		3.90	
		Btu/hW		13.3	
SEER	Cooling	Btu/hW		21.3	
HSPF	Heating	Btu/hW		11.7	
Power factor	Cooling	%		96.7	
	Heating	%		98.4	
NOTES:					
Specifications are based on the following conditions:					
<ul style="list-style-type: none"> Cooling: Indoor temperature of 80°FDB/67°FWB (26.67°CDB/19.44°CWB), and outdoor temperature of 95°FDB/75°FWB (35°CDB/23.9°CWB). Heating: Indoor temperature of 70°FDB/60°FWB (21.11°CDB/15.56°CWB), and outdoor temperature of 47°FDB/43°FWB (8.33°CDB/6.11°CWB). *: Heating (17°F): Indoor temperature of 70°FDB/60°FWB (21.11°CDB/15.56°CWB), and outdoor temperature of 17°FDB/15°FWB (-8.33°CDB/-9.44°CWB). Test conditions are based on AHRI 210/240 2017. Pipe length: 24 ft 7 in (7.5 m), Height difference: 0 ft (0 m). (Between outdoor unit and indoor unit.) Standard static pressure: 0.18 inWG (45 Pa) 					

1-2. Outdoor unit

Type			Inverter, Heat pump	
Model name			AOUH12LUAS1	
Power supply			208/230 V~ 60 Hz	
Power supply intake			Outdoor unit	
Available voltage range			187—253 V	
Starting current			6.4	
Fan	Airflow rate	Cooling	CFM (m ³ /h)	
		Heating		
	Type × Qty	Propeller fan × 1		
	Motor output	W		
Sound pressure level *			49	
Cooling			48	
Heating			49	
Heat exchanger type	Dimensions (H × W × D)	in (mm)	Main 1: 23-1/8 × 34-11/16 × 11/16 (588 × 881 × 18.19) Main 2: 23-1/8 × 33-1/2 × 11/16 (588 × 851 × 18.19)	
	Fin pitch	FPI	Main 1: 20 Main 2: 20	
	Rows × Stages	Main 1: 1 × 28 Main 2: 1 × 28		
	Pipe type	Copper		
	Fin type	Type (Material)	Aluminum	
		Surface treatment	PC fin	
Compressor	Type	DC twin rotary		
Motor output			900	
Refrigerant	Type	R410A		
	Charge	lb oz	2 lb 10 oz	
		g	1,200	
Refrigerant oil	Type	RB68		
	Amount	in ³ (cm ³)	24.4 (400)	
	Material	Steel sheet		
Enclosure	Color			
	Beige Approximate color of Munsell 10YR 7.5/1.0			
Dimensions (H × W × D)	Net	in (mm)	24-7/8 × 31-7/16 × 11-7/16 (632 × 799 × 290)	
	Gross		27-1/4 × 37 × 14-3/4 (692 × 940 × 375)	
Weight	Net	lb (kg)	84 (38)	
	Gross		95 (43)	
Connection pipe	Size	Liquid	Ø1/4 (Ø6.35)	
		Gas	Ø3/8 (Ø9.52)	
	Method		Flare	
	Pre-charge length		49 (15)	
	Max. length		66 (20)	
	Max. height difference		49 (15)	
Operation range	Cooling	°F (°C)	14 to 115 (-10 to 46)	
	Heating		-5 to 75 (-21 to 24)	
Drain hose	Material	LDPE		
	Tip diameter	in (mm)	Ø1/2 (Ø13.0) (I.D.), Ø5/8 to Ø11/16 (Ø16.0 to Ø16.7) (O.D.)	
NOTES:				
<ul style="list-style-type: none"> • Specifications are based on the following conditions: <ul style="list-style-type: none"> – Cooling: Indoor temperature of 80°FDB (26.67°CDB)/67°FWB (19.44°CWB), and outdoor temperature of 95°FDB (35°CDB)/75°FWB (23.9°CWB). – Heating: Indoor temperature of 70°FDB (21.11°CDB)/59°FWB (15°CWB), and outdoor temperature of 47°FDB (8.33°CDB)/43°FWB (6.11°CWB). – Pipe length: 24 ft 6 in (7.5 m), Height difference: 0 ft (0 m). (Between outdoor unit and indoor unit.) • Protective function might work when using it outside the operation range. • *: Sound pressure level <ul style="list-style-type: none"> – Measured values in manufacturer's anechoic chamber. – Because of the surrounding sound environment, the sound levels measured in actual installation conditions might be higher than the specified values here. 				

2. Dimensions

2-1. Indoor unit

■ Model: ARUH12LUAS

Unit: in (mm)

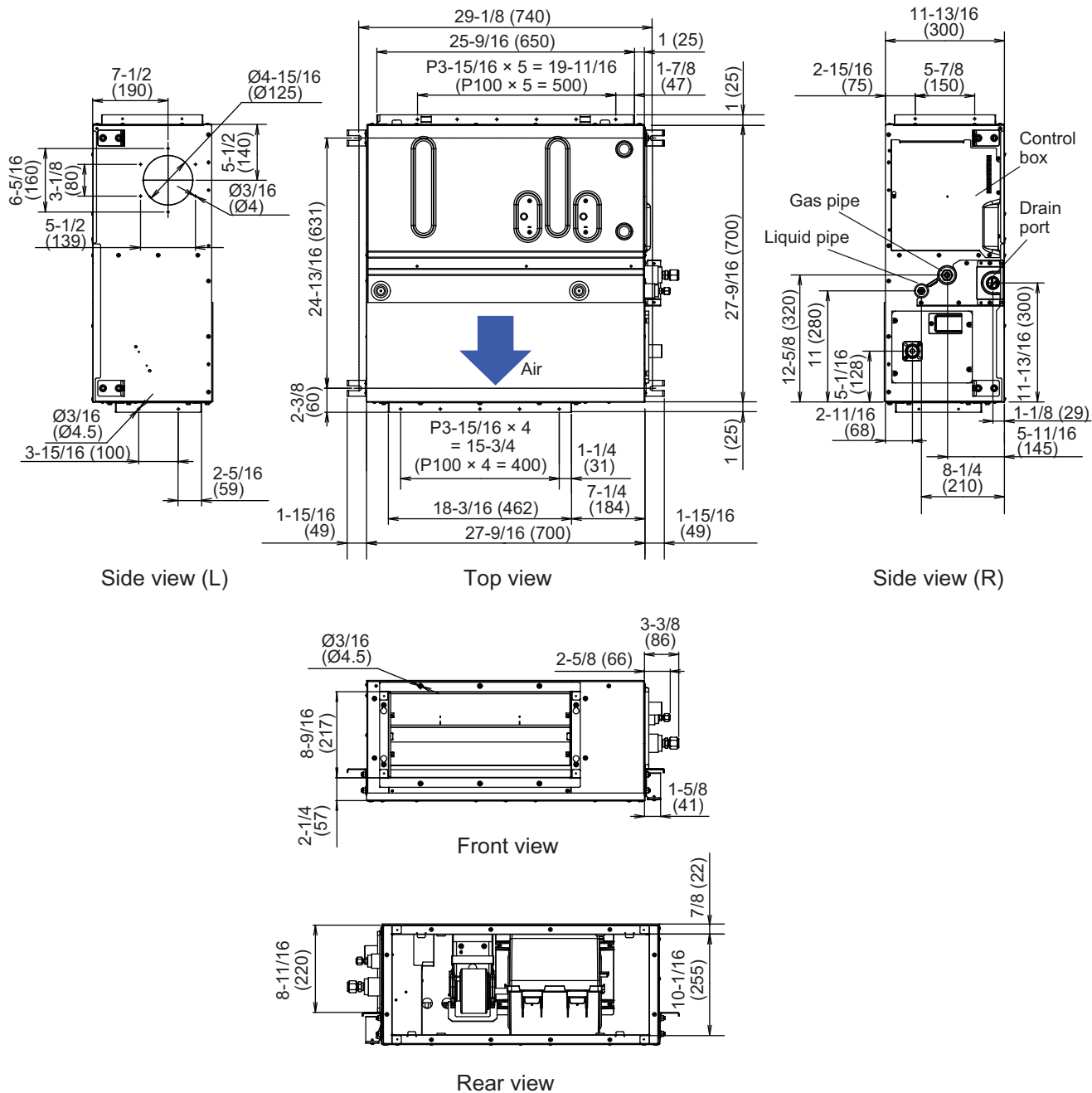

■ Installation space requirement

Provide sufficient installation space for product safety.

NOTE: The detailed component shape depends on the model.

● Model: ARUH12LUAS

Unit: in (mm)

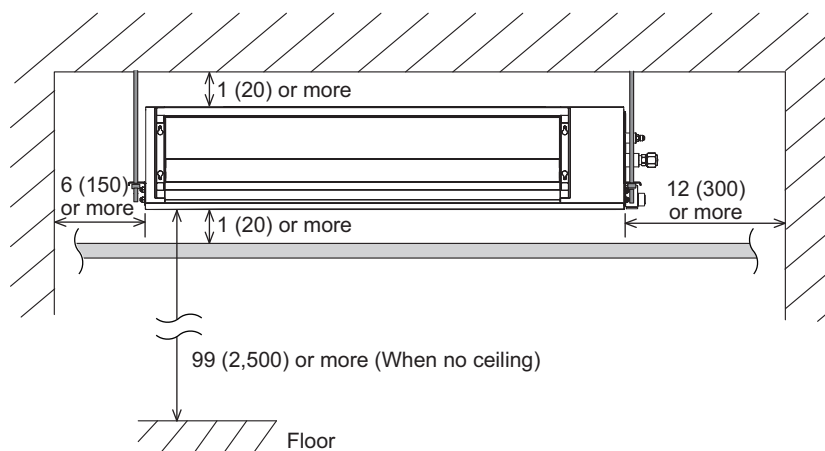

■ Maintenance space requirement

For future maintenance and maintenance access, provide sufficient maintenance space.

NOTES:

- Do not place any wiring or illumination in the maintenance space, as they will impede service.
- The detailed component shape depends on the model.

● Model: ARUH12LUAS

Unit: in (mm)

- Provide a maintenance access for maintenance purposes.

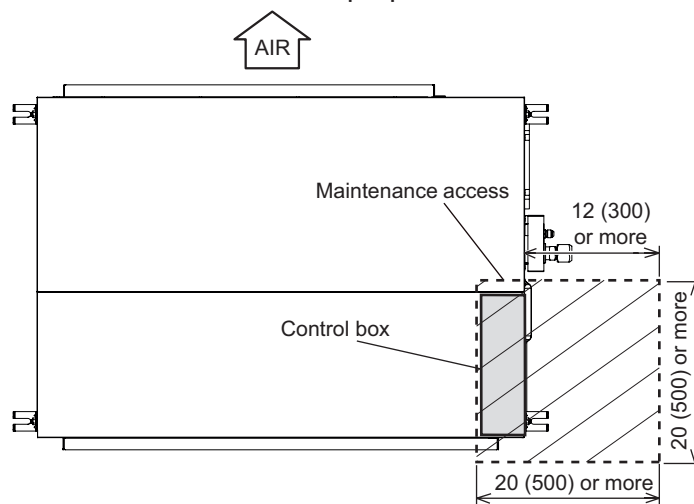

Bottom view

- The maintenance access necessary for fan units and filter maintenance.

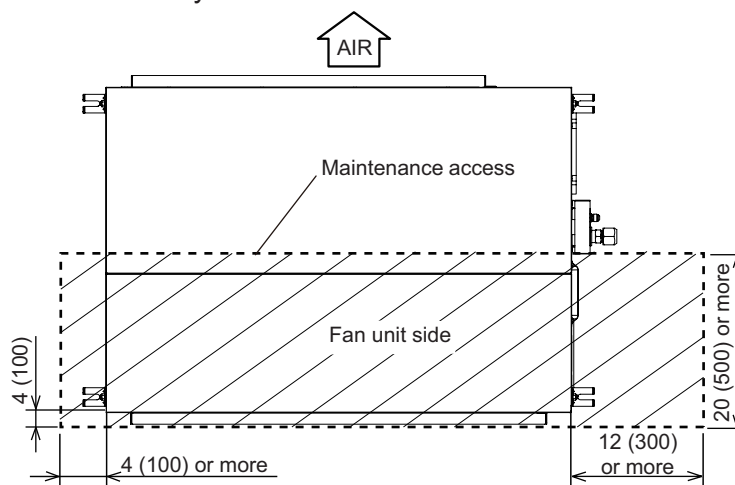

Bottom view

2-2. Outdoor unit

■ Model: AOUH12LUAS1

Unit: in (mm)

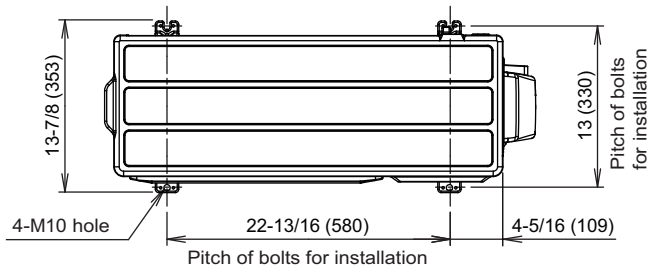

Top view

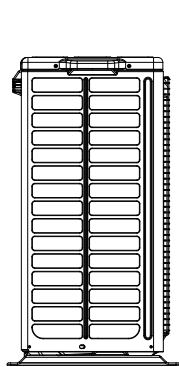

Side view

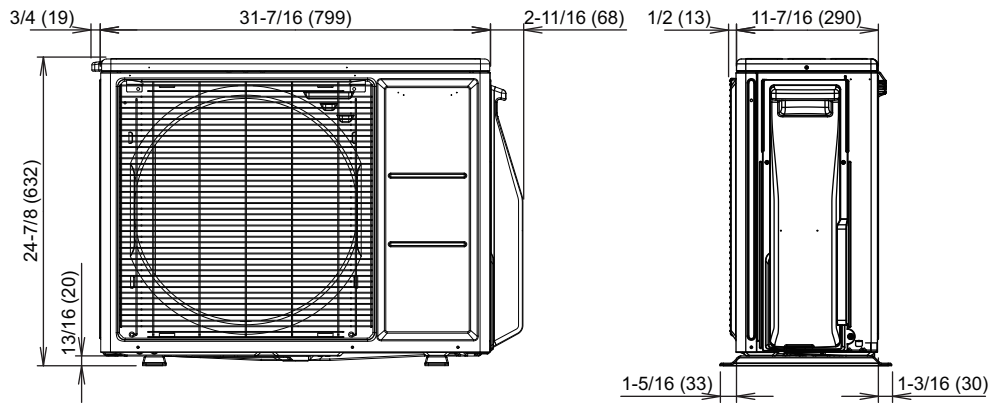

Front view



Side view

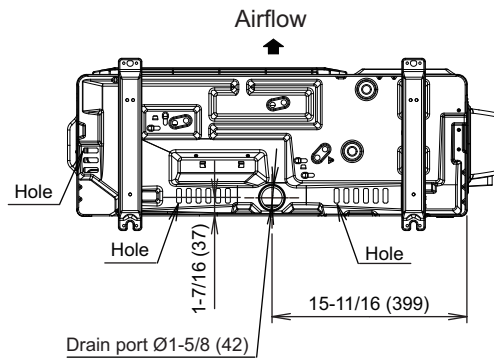

Bottom view

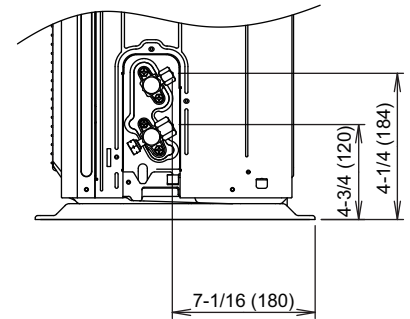

Side view (Valve part)

2. TECHNICAL DATA AND PARTS LIST

CONTENTS

2. TECHNICAL DATA AND PARTS LIST

1. Precautions	02-1
2. Indoor unit parts list	02-2
2-1. Model: ARUH12LUAS	02-2
3. Outdoor unit parts list	02-4
3-1. Model: AOUH12LUAS1	02-4
4. Accessories	02-8
4-1. Indoor unit	02-8
4-2. Outdoor unit.....	02-8
5. Optional parts	02-9
5-1. Indoor unit	02-9
6. Refrigerant system diagrams	02-12
6-1. Model: AOUH12LUAS1	02-12
7. Wiring diagrams	02-13
7-1. Indoor unit	02-13
7-2. Outdoor unit.....	02-14
8. PC board diagrams	02-15
8-1. Model: ARUH12LUAS	02-15
8-2. Model: AOUH12LUAS1	02-16

1. Precautions

When you start servicing, pay attention to the following points. For detailed precautions, refer to the installation manual of the products.

CAUTION

- Service personnel
 - Any person who is involved with working on or breaking into a refrigerant circuit should hold a current valid certificate from an industry-accredited assessment authority, which authorizes their competence to handle refrigerants safely in accordance with an industry recognized assessment specification.
 - Servicing shall only be performed as recommended by the equipment manufacturer. Maintenance and repair requiring the assistance of other skilled personnel shall be carried out under the supervision of the person competent in the use of flammable refrigerants.
 - Servicing shall be performed only as recommended by the manufacturer.
 - Work
 - Work in confined spaces shall be avoided.
 - The area around the workspace shall be sectioned off.
 - Electric shock may occur. After turning off the power, always wait 5 minutes before touching electrical components.
 - Do not touch the fins of the heat exchanger. Touching the heat exchanger fins could result in damage to the fins or personal injury such as skin rupture.
 - Do not place any other electrical products or household belongings under the product.
 - Condensation dripping from the product might get them wet, and may cause damage or malfunction to the property.
-
- Service parts information and design are subject to change without notice for product improvement.
 - For the latest information of the service parts, refer to our Service Portal.
<https://fujitsu-general.force.com/portal/>
 - Precise figure of the service parts listed in this manual may differ from the actual service parts.

2. Indoor unit parts list

2-1. Model: ARUH12LUAS

■ Chassis

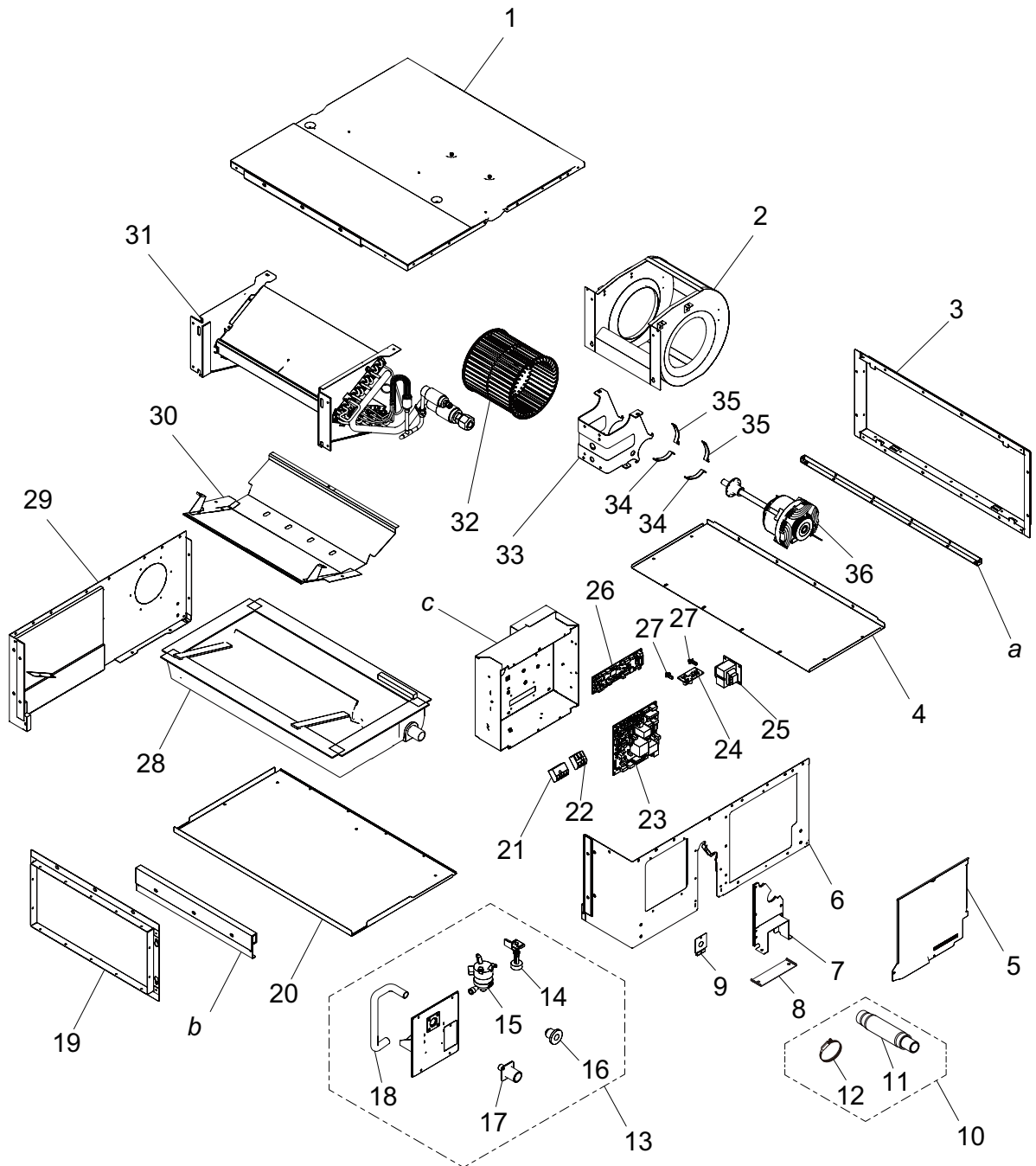

TECHNICAL DATA
AND PARTS LIST

TECHNICAL DATA
AND PARTS LIST

Item no.	Part no.	Part name	Service part
1	9381748075	Top panel sub assy	◆
2	9381829033	Casing assy	◆
3	9381723027	Intake frame assy	◆
4	9381974009	Service panel	◆
5	9381769032	Control box cover sub assy	◆
6	9381750054	Side panel R sub assy	◆
7	9381751006	Pipe panel sub assy	◆
8	9381616008	Drain hose cover	◆
9	9383778001	Conduit plate	◆
10	9378450219	Hose sub assy	◆
11	9377785114	Drain hose assy	◆
12	9378451087	Hose band sub assy	◆
13	9381766017	Drain pump sub assy	◆
14	9900465070	Float switch	◆
15	9900890018	Pump assy	◆
16	9381578009	Drain cap	◆
17	9381565009	Drain port	◆
18	9381576005	Drain hose	◆
19	9381722020	Outlet frame assy	◆
20	9381585038	Main panel sub assy	◆
21	9900896027	Terminal 5P (Remote)	◆
22	9900568009	Terminal 3P (Power)	◆
23	9710032028	Power supply PCB	◆
24	9710019005	Communication PCB	◆
25	9900921019	Reactor assy	◆
26	9711870216	Main PCB	◆
27	0600063023	PCB holder	◆
28	9381752034	Drain pan sub assy	◆
29	9381749003	Side panel L sub assy	◆
30	9383937002	Drain pan cover 1 sub assy	◆
31	9383816154	Evaporator total assy	◆
32	9383695001	Sirocco fan assy	◆
33	9382384005	Motor bracket assy	◆
34	9380521006	Motor band B	◆
35	9381597000	Motor band assy	◆
36	9603694012	DC fan motor	◆
—	9710343087	Wire with connector (CN300 on Main PCB—Terminal 5P [Remote])	◆
—	9710171048	Wire with connector (CN54 on Main PCB—CN303 on Power supply PCB)	◆
—	9710260001	Wire with connector (CN66 on Main PCB—CN410 on Power supply PCB)	◆
—	9710206030	Wire with connector (CN55 on Main PCB—CN304 on Power supply PCB)	◆
—	9710161018	Wire with connector (CN304 on Power supply PCB—Reactor)	◆
—	9710177026	Wire with connector (CN46 on Main PCB—Terminal 5P [EX.IN])	◆
—	9703299278	Room temperature thermistor	◆
—	9900892005	Pipe temperature thermistor	◆
a	—	Intake angle	—
b	—	Outlet angle sub assy	—
c	—	Control box assy	—

3. Outdoor unit parts list

3-1. Model: AOUH12LUAS1

■ Exterior parts and chassis

TECHNICAL DATA
AND PARTS LIST

TECHNICAL DATA
AND PARTS LIST

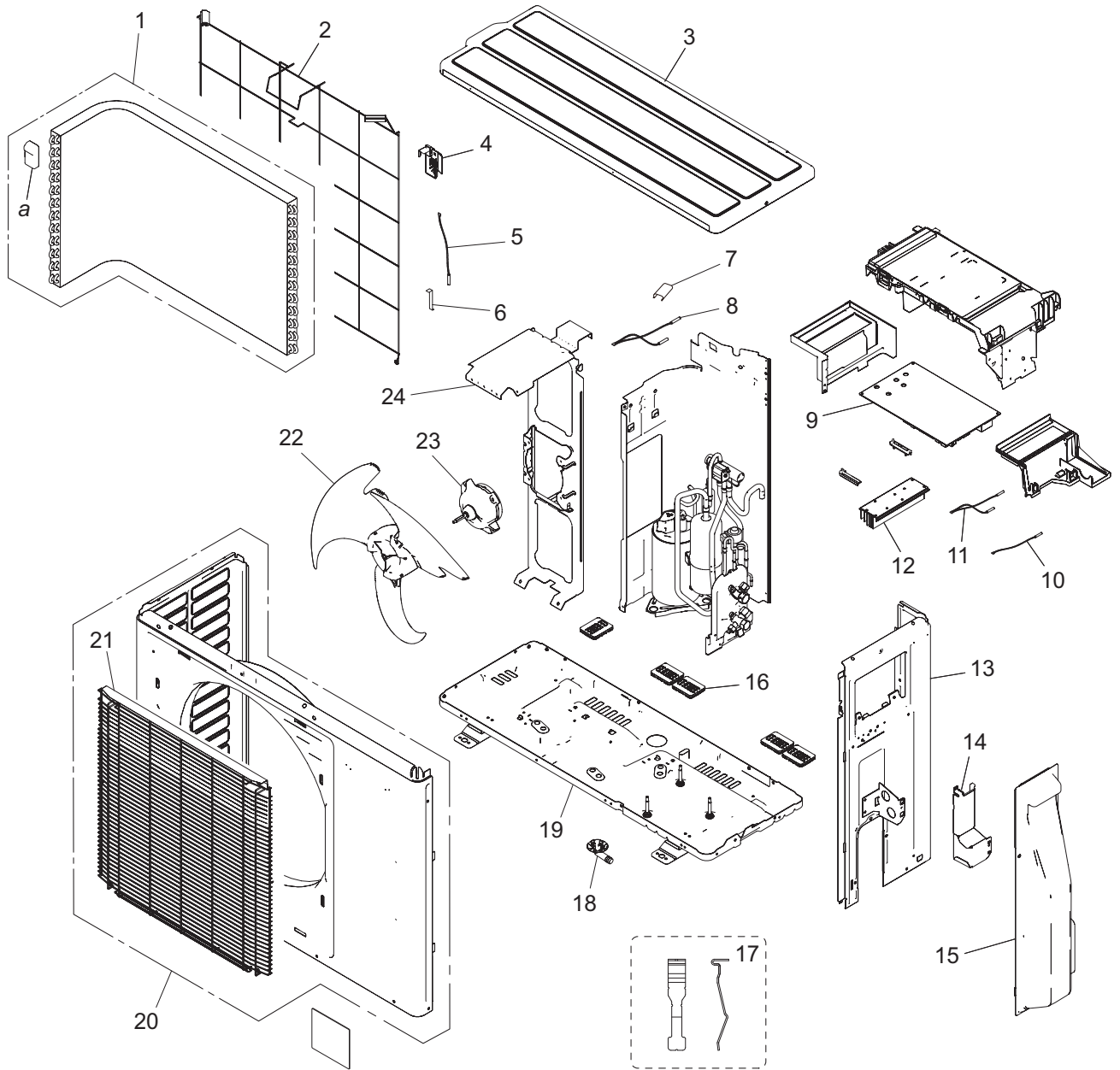

Item no.	Part no.	Part name	Service part
1	9323834194	Heat exchanger unit	◆
2	9377854001	Protective net assy	◆
3	9322556028	Top panel assy	◆
4	9322327000	Thermistor holder	◆
5	9900984014	Thermistor (Heat exchanger)	◆
6	313728262708	Thermistor spring A	◆
7	9300089012	Thermistor spring	◆
8	9900935054	Thermistor assy (Discharge temp.)	◆
9	9709688410	Main PCB	◆
10	9900985011	Thermistor assy (Compressor temp.)	◆
11	9900565060	Thermistor assy (Outdoor temp.)	◆
12	9322420046	Heat sink	◆
13	9322552242	Cabinet right assy	◆
14	9384276001	Conduit cover	◆
15	9322570062	Switch cover assy	◆
16	9810028006	Thermistor stopper	◆
17	9383720000	Drain cap assy	◆
18	9322144003	Drain pipe	◆
19	9323550025	Base assy	◆
20	9322555182	Front panel assy	◆
21	9384273000	Fan guard	◆
22	9322150004	Propeller fan	◆
23	9604091001	DC fan motor	◆
24	9322553027	Motor bracket assy	◆
—	9709488027	Wire with terminal (Terminal—Earth)	◆
a	—	Hair pin cushion	—

Compressor

TECHNICAL DATA
AND PARTS LIST

TECHNICAL DATA
AND PARTS LIST

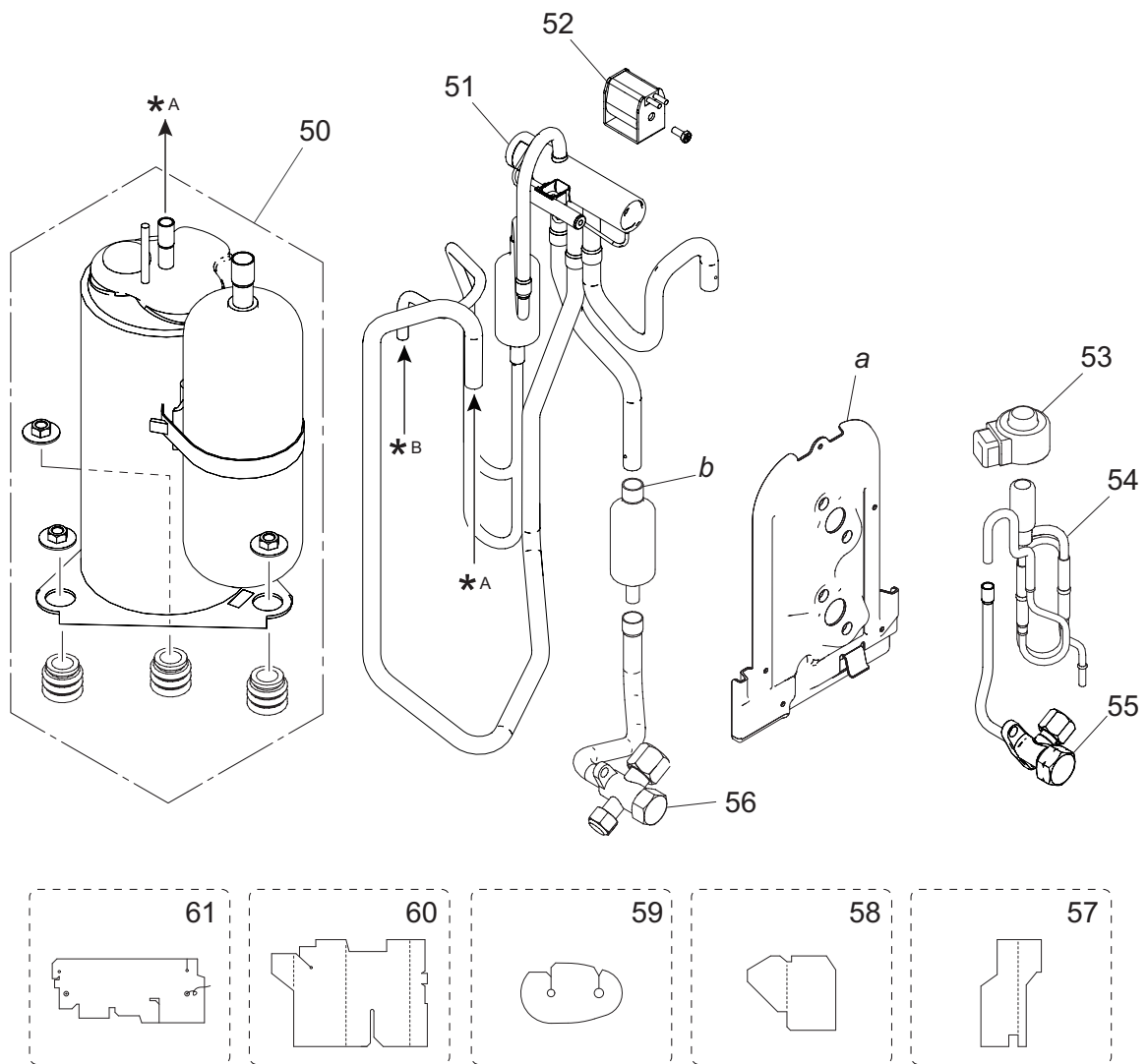







Item no.	Part no.	Part name	Service part
50	9323825208	Compressor unit	◆
51	9322446015	4-way valve assy	◆
52	9970194023	Solenoid	◆
53	9970222016	Expansion valve coil	◆
54	9322463029	Pulse motor valve assy	◆
55	9322474001	2-way valve assy	◆
56	9322850010	3-way valve assy	◆
57	9322824004	Sound insulator K	◆
58	9323045002	Sound insulator V	◆
59	9322501004	Sound insulator H	◆
60	9322847003	Sound insulator F	◆
61	9324014014	Sound insulator B	◆
<i>a</i>	—	Valve bracket	—
<i>b</i>	—	Muffler	—

4. Accessories

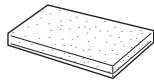
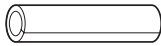
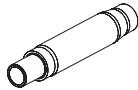
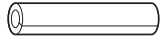

4-1. Indoor unit

■ Model: ARUH12LUAS

Part name	Exterior	Qty	Part name	Exterior	Qty
Operation manual		1	Cable tie (large)		4
Installation manual (indoor unit)		1	Cable tie (medium)		1
Washer		8	Drain hose insulation		1
Coupler heat insulation (large)		1	Drain hose		1
Coupler heat insulation (small)		1	Hose band		1

4-2. Outdoor unit

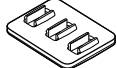

■ Model: AOUH12LUAS1

Part name	Exterior	Qty	Part name	Exterior	Qty
Installation manual		1	Cable tie		2
Drain pipe		1	Drain cap		5

5. Optional parts



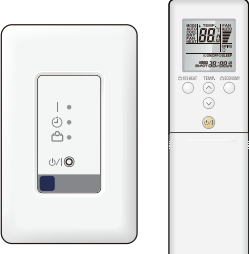

5-1. Indoor unit

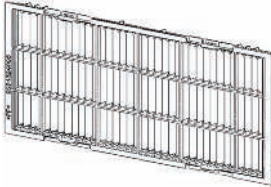
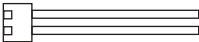
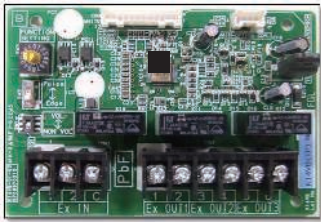
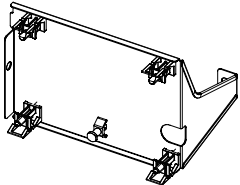

■ Controllers

Exterior	Part name	Model name	Summary
	Wired Remote Controller	UTY-RNRUZ*	Easy finger touch operation with LCD panel. Backlit LCD enables easy operation in a dark room. Wire type: Non-polar 2-wire
	Simple Remote Controller	UTY-RSRY	Compact remote controller concentrates on the basic functions such as Start/Stop, fan control, temperature setting, and operation mode. Wire type: Non-polar 2-wire
	Simple Remote Controller	UTY-RHRY	Compact remote controller concentrates on the basic functions such as Start/Stop, fan control, and temperature setting. Wire type: Non-polar 2-wire
	IR Receiver Kit with Wireless Remote Controller	UTY-LBTUM	Unit control is performed by Wireless Remote Controller

NOTE: Available functions may differ by the remote controller. For details, refer to the operation manual.

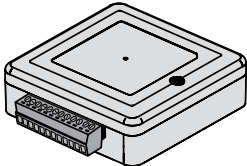
Others

Exterior	Part name	Model name	Summary
	Remote Sensor Unit	UTY-XSZX	Thermo-sensor for sensing the temperature of arbitrary place in the room.
	Long-life Filter	UTD-LFNC	Long-life Filter can be mounted to the indoor unit.
	External Connect Kit	UTY-XWZXZG	Use to connect with various peripheral devices and air conditioner PCB. For control output port.
	External Input and Output PCB	UTY-XCSX	Use to connect with external devices and air conditioner PCB.
	External Input and Output PCB Bracket	UTZ-GXNA	For installing the External input and output PCB.
	WLAN Adapter	UTY-TFSXZ2	Remotely manage an air conditioning system using mobile devices such as smartphones and tablets. For connection indoor unit with UART interface. Appropriate application for each region is required to use this option. For details, contact FGL sales company.
	Modbus Converter	UTY-VMSX	For connection between indoor unit with UART interface and a Modbus open network.
	KNX Converter	UTY-VKSX	For connection between indoor unit with UART interface and a KNX open network.
	Thermostat Converter	UTY-TTRX	This converter can control Fujitsu General products using a third-party thermostat controller.

Exterior	Part name	Model name	Summary
	Network Converter	UTY-VTGX	This converter is required when connecting single split system to VRF network system.
	Network Converter (AC power supply)	UTY-VTGXV	This converter is required when connecting single split system to VRF network system.
	External Switch Controller	UTY-TERX	Air conditioner switching can be controlled by connecting other external sensor switches.

6. Refrigerant system diagrams

6-1. Model: AOUH12LUAS1

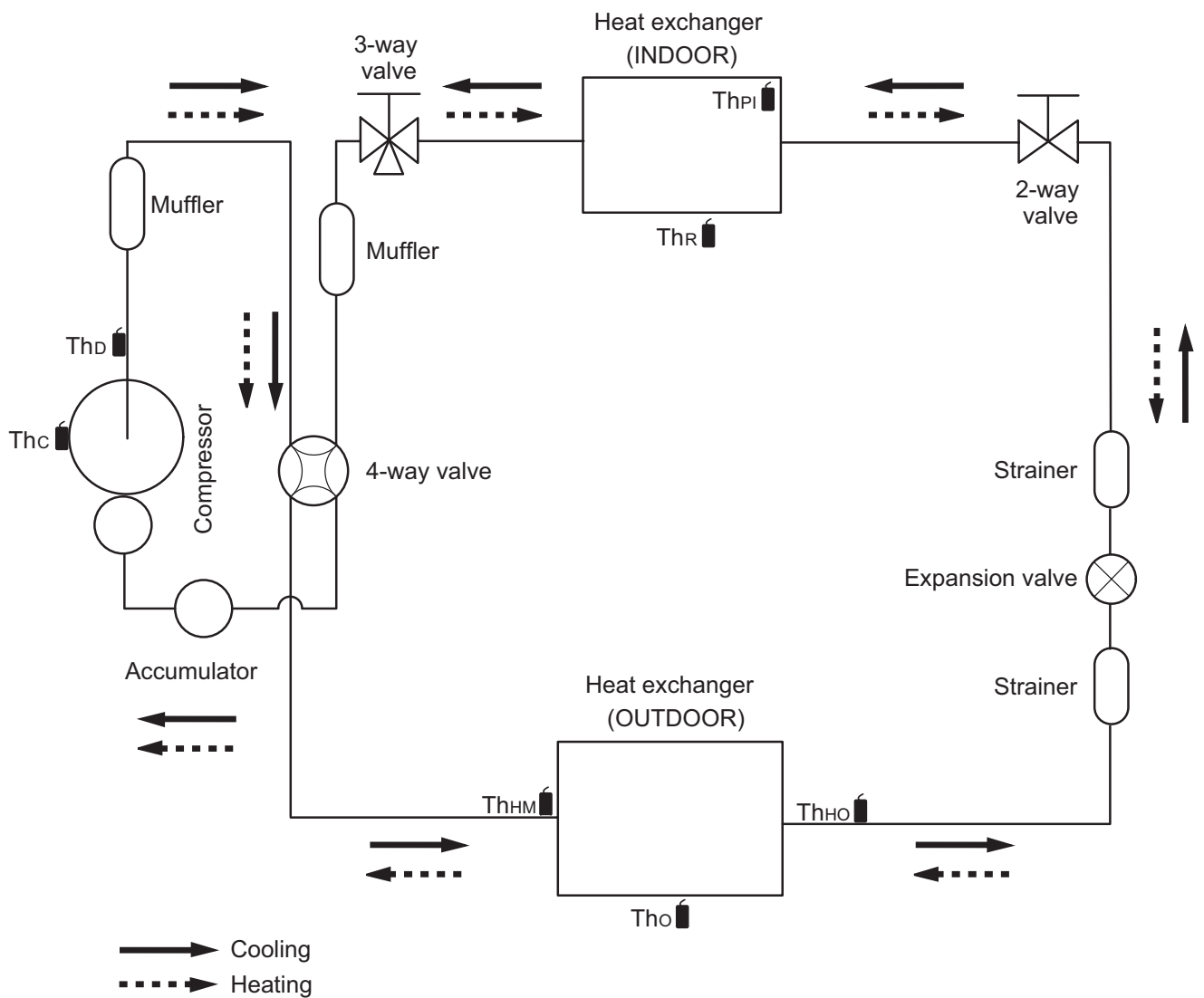

- Thc : Thermistor (Compressor temperature)
- Thd : Thermistor (Discharge temperature)
- Thhm : Thermistor (Heat exchanger middle temperature)
- Tho : Thermistor (Outdoor temperature)
- Thho : Thermistor (Heat exchanger out temperature)
- Thpi : Thermistor (Pipe temperature)
- Thr : Thermistor (Room temperature)

7. Wiring diagrams

7-1. Indoor unit

Model: ARUH12LUAS

TECHNICAL DATA AND PARTS LIST

TECHNICAL DATA AND PARTS LIST

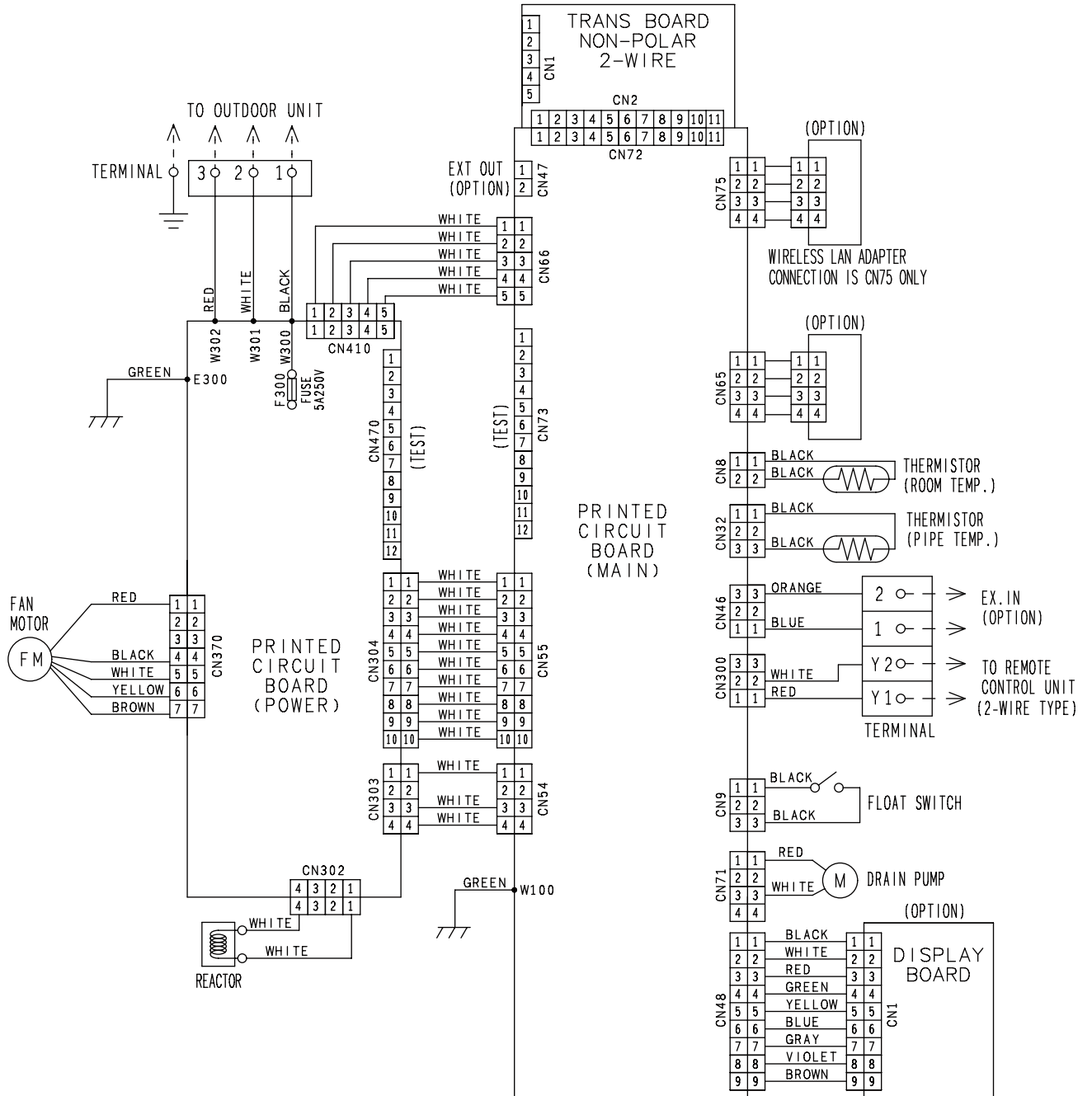

7-2. Outdoor unit

Model: AOUH12LUAS1

TECHNICAL DATA AND PARTS LIST

TECHNICAL DATA AND PARTS LIST

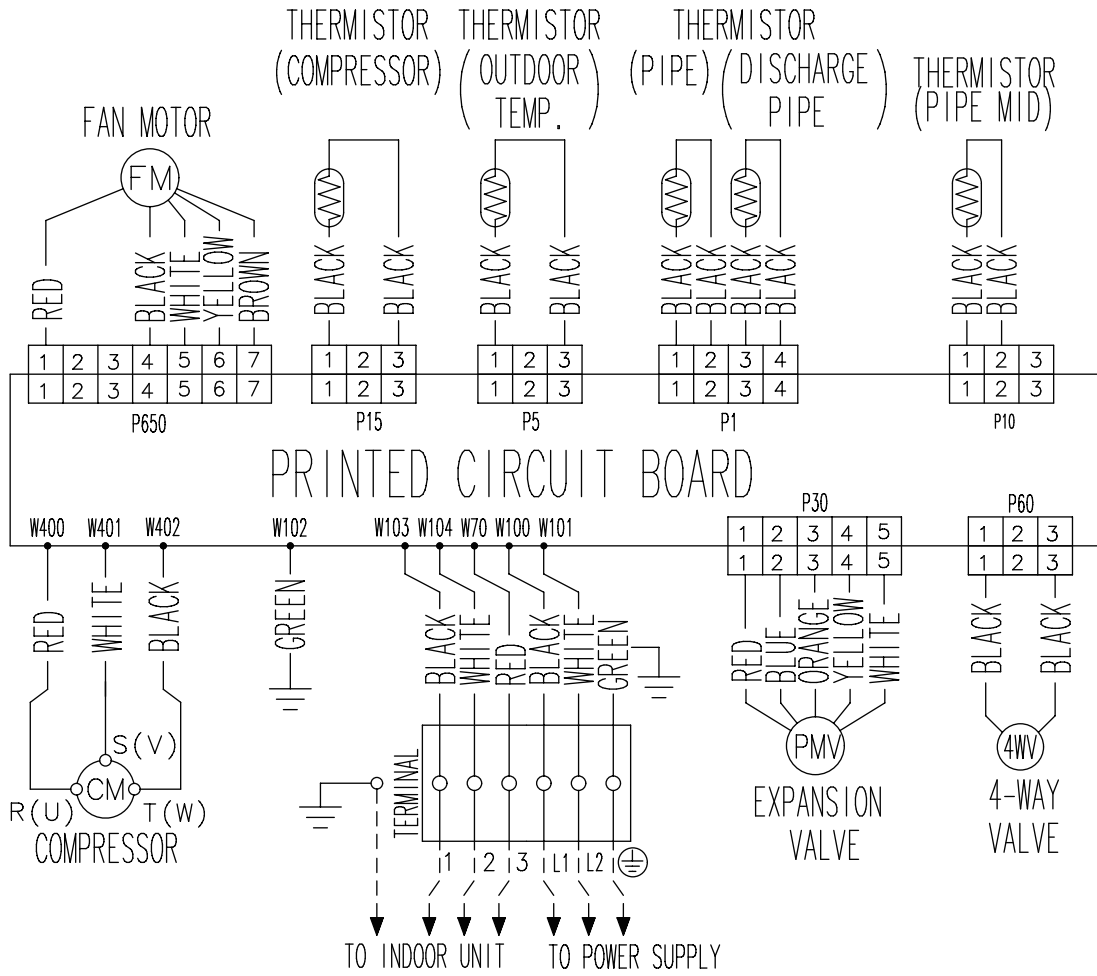

8. PC board diagrams

8-1. Model: ARUH12LUAS

TECHNICAL DATA AND PARTS LIST

TECHNICAL DATA AND PARTS LIST

CONTROL UNIT 12 model : EZ-0210BHSE

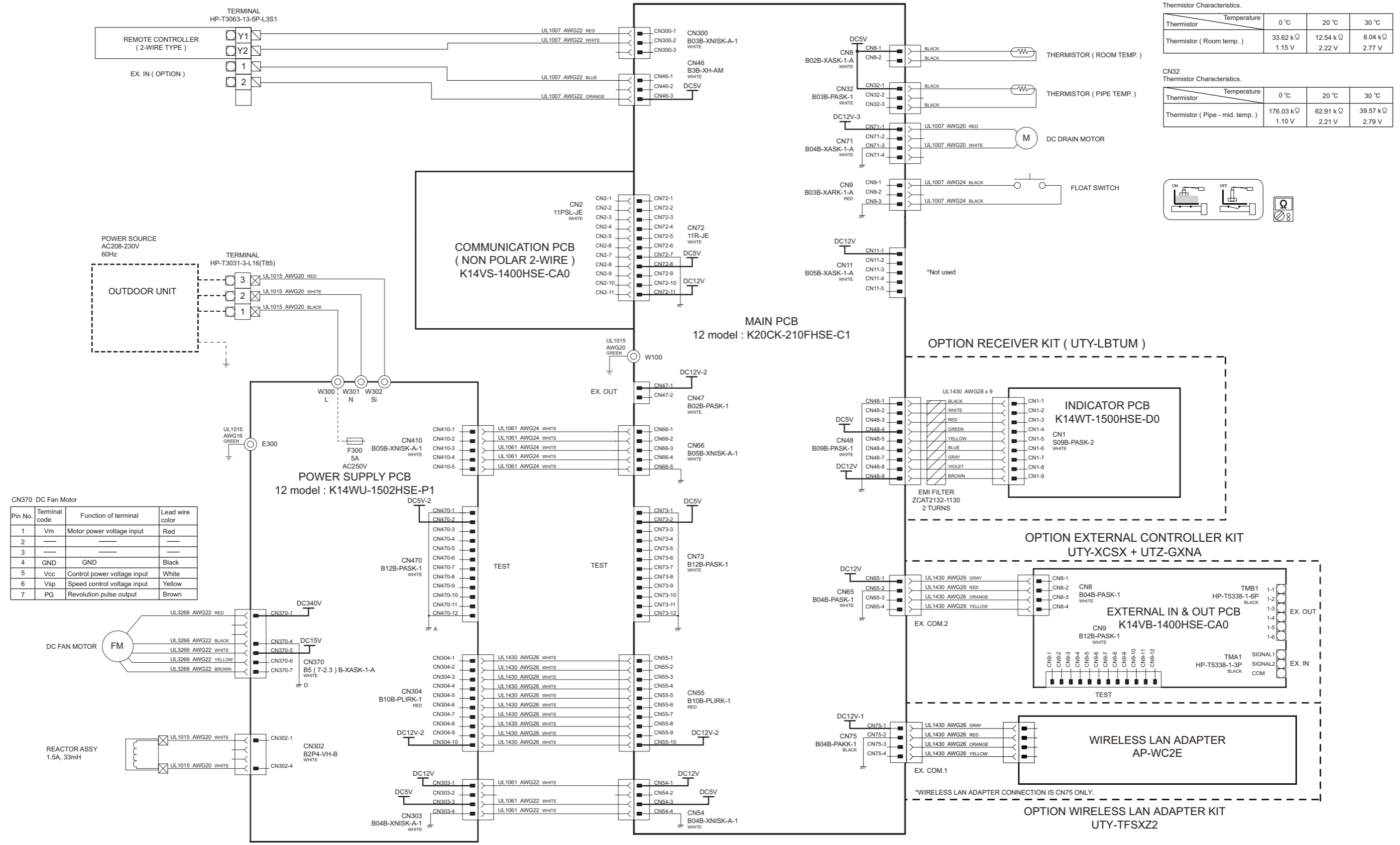

CN8 Thermistor Characteristics.

Thermistor	Temperature	0 °C	20 °C	30 °C
Thermistor (Room temp.)		33.62 kΩ	12.54 kΩ	8.04 kΩ
		1.15 V	2.22 V	2.77 V

CN32 Thermistor Characteristics.

Thermistor	Temperature	0 °C	20 °C	30 °C
Thermistor (Pipe - mid. temp.)		176.03 kΩ	62.91 kΩ	39.57 kΩ
		1.10 V	2.21 V	2.79 V

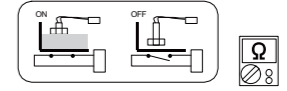

CN370 DC Fan Motor

Pin No.	Terminal code	Function of terminal	Lead wire color
1	Vm	Motor power voltage input	Red
2	—	—	—
3	—	—	—
4	GND	GND	Black
5	Vcc	Control power voltage input	White
6	Vsp	Speed control voltage input	Yellow
7	PG	Revolution pulse output	Brown

*WIRELESS LAN ADAPTER CONNECTION IS CN75 ONLY.

8-2. Model: AOUH12LUAS1

INVERTER ASSEMBLY 12 model : EZ-0200HHUE

TECHNICAL DATA
AND PARTS LIST

TECHNICAL DATA
AND PARTS LIST

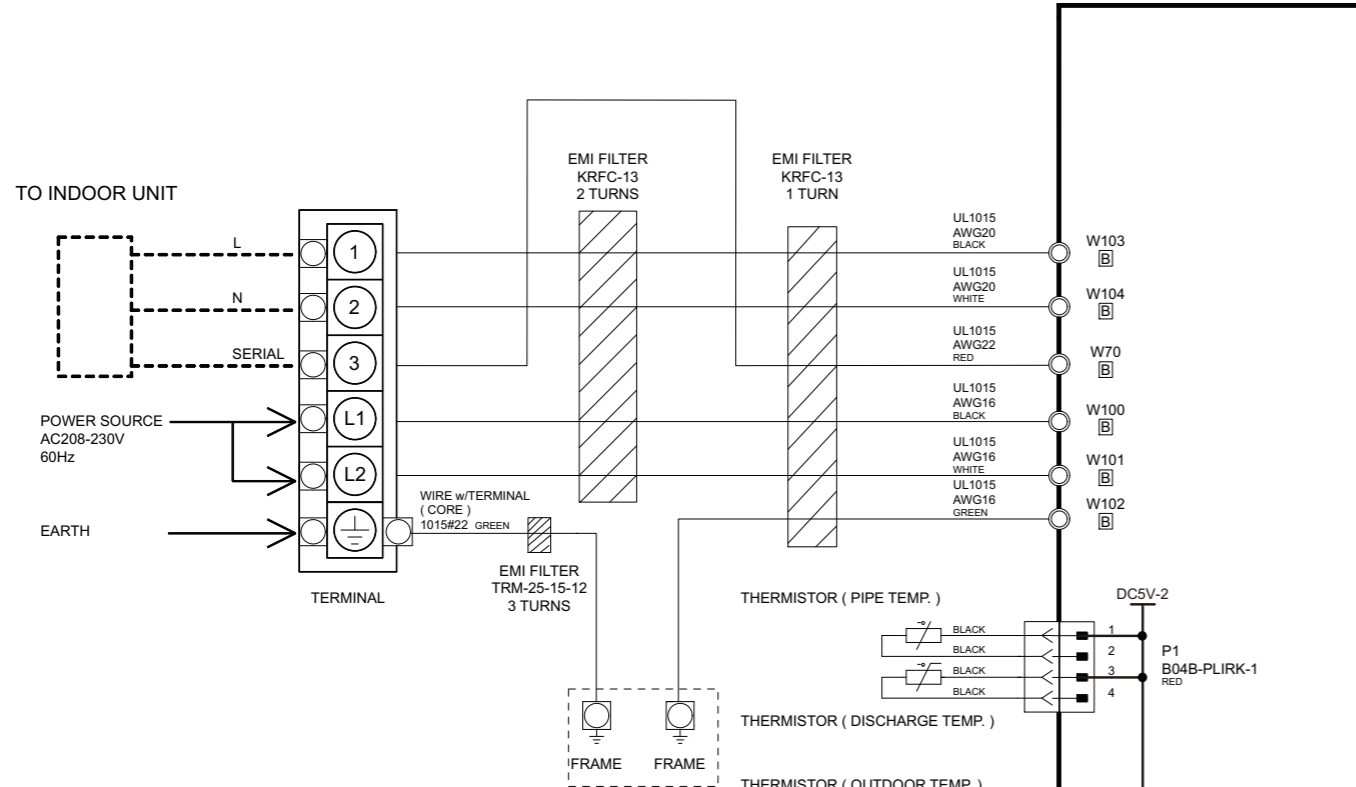

MAIN PCB 12 model : H12LBTA(U)-A01-00-SV

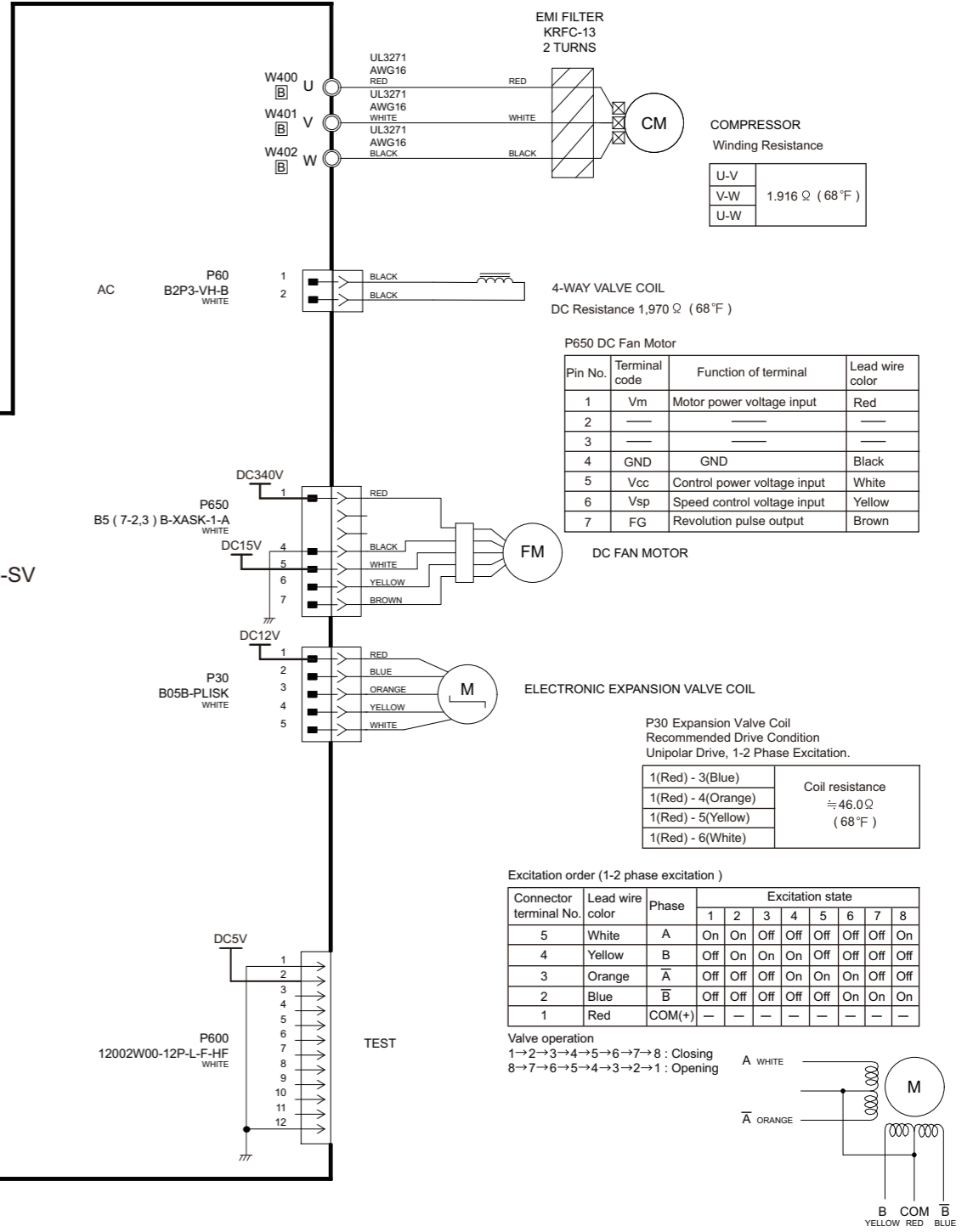

P1 Thermistor Characteristics.

Temperature	(32°F)	(68°F)	(86°F)
Thermistor			
Thermistor (Pipe temp.)	16.05 kΩ	5.98 kΩ	3.84 kΩ
Thermistor (Discharge temp.)	168.60 kΩ	62.55 kΩ	40.01 kΩ
	0.36 V	0.86 V	1.23 V

P5 Thermistor Characteristics.

Temperature	(32°F)	(68°F)	(86°F)
Thermistor			
Thermistor (Outdoor temp.)	35.21 kΩ	12.64 kΩ	7.97 kΩ
	2.61 V	3.76 V	4.14 V

P10 Thermistor Characteristics.

Temperature	(32°F)	(68°F)	(86°F)
Thermistor			
Thermistor (Pipe-mid. temp.)	16.05 kΩ	5.95 kΩ	3.84 kΩ
	1.92 V	3.13 V	3.61 V

P15 Thermistor Characteristics.

Temperature	(32°F)	(68°F)	(86°F)
Thermistor			
Thermistor (Compressor temp.)	168.60 kΩ	62.55 kΩ	40.01 kΩ
	0.36 V	0.86 V	1.23 V

3. TROUBLESHOOTING

CONTENTS

3. TROUBLESHOOTING

1. Error code	03-1
1-1. How to check the error memory.....	03-1
1-2. How to erase the error memory	03-1
1-3. Error code table (Wired remote controller).....	03-2
2. Troubleshooting with error code	03-3
2-1. E: 11.X. Serial communication error (Serial reverse transfer error) (Outdoor unit)	03-3
2-2. E: 11.X. Serial communication error (Serial forward transfer error) (Indoor unit)	03-5
2-3. E: 12.X. Wired remote controller communication error (Indoor unit)	03-7
2-4. E: 15.X. Automatic air flow adjustment error (Indoor unit)	03-8
2-5. E: 18.X. External communication error (Indoor unit)	03-9
2-6. E: 23.X. Combination error (Outdoor unit)	03-10
2-7. E: 26.X. Address setting error in wired remote controller (Indoor unit)	03-11
2-8. E: 29.X. Connected unit number error (Indoor unit)	03-12
2-9. E: 32.X. Indoor unit main PCB error (Indoor unit)	03-13
2-10. E: 33.X. Indoor unit motor electricity consumption detection error (Indoor unit).....	03-14
2-11. E: 35.X. MANUAL AUTO button error (Indoor unit)	03-15
2-12. E: 39.X. Indoor unit power supply error for fan motor (Indoor unit)	03-16
2-13. E: 3A.X. Indoor unit communication circuit error (Indoor unit).....	03-17
2-14. E: 41.X. Room temperature sensor error (Indoor unit).....	03-18
2-15. E: 42.X. Indoor unit heat exchanger sensor error (Indoor unit).....	03-19
2-16. E: 44.X. Human sensor error	03-20
2-17. E: 51.X. Indoor unit fan motor error (Indoor unit)	03-21
2-18. E: 53.X. Drain pump error (Indoor unit).....	03-22
2-19. E: 62.X. Outdoor unit main PCB error (Outdoor unit).....	03-23
2-20. E: 63.X. Inverter error (Outdoor unit)	03-24
2-21. E: 64.X. PFC circuit error (Outdoor unit).....	03-25
2-22. E: 65.X. IPM error (Outdoor unit).....	03-26
2-23. E: 71.X. Discharge thermistor error (Outdoor unit)	03-28
2-24. E: 73.X. Outdoor unit heat exchanger thermistor error (Outdoor unit)	03-29
2-25. E: 74.X. Outdoor temperature thermistor error (Outdoor unit)	03-30
2-26. E: 84.X. Current sensor error (Outdoor unit).....	03-31
2-27. E: 94.X. Trip detection (Outdoor unit)	03-32
2-28. E: 95.X. Compressor motor control error (Outdoor unit)	03-33
2-29. E: 97.X. Outdoor unit fan motor error (Outdoor unit).....	03-34
2-30. E: 99.X. 4-way valve error (Outdoor unit)	03-35
2-31. E: A1.X. Discharge temperature error (Outdoor unit).....	03-37
3. Troubleshooting without error code.....	03-39
3-1. Indoor unit—No power.....	03-39
3-2. Outdoor unit—No power	03-40
3-3. No operation (Power is on).....	03-41
3-4. No cooling/No heating	03-42
3-5. Abnormal noise.....	03-44

CONTENTS (continued)

3-6. Water leaking.....	03-45
3-7. Louver operation abnormal.....	03-46
4. Service parts information	03-47
4-1. Compressor.....	03-47
4-2. Inverter compressor.....	03-48
4-3. Outdoor unit Electronic Expansion Valve (EEV)	03-49
4-4. Indoor unit fan motor	03-51
4-5. Outdoor unit fan motor.....	03-52
5. Thermistor resistance values.....	03-53
5-1. Indoor unit	03-53
5-2. Outdoor unit.....	03-54

1. Error code

When a problem occurs in the system or the connected device, the error content is notified by displaying the code.

NOTE: This function is only available in a system with indoor or IR receiver units equipped with indicator lamps to show the error content.

Errors, once displayed, will be automatically stored in the PC board of the indoor unit. Even if the power is disconnected, the memory containing the error history will not be erased.

If another error occurs later, the stored error memory will be updated automatically and replaced with the new one. (Previous error will be erased.)

1-1. How to check the error memory

When an error occurs, the operation lamp (Green) and the timer lamp (Orange) indicate the error content by blinking. To check the error memory, follow the procedures below.

1. Stop the operation of the air conditioner, and then disconnect the power supply.
2. Reconnect the power supply.
3. In one of the following two methods, the memorized error is only displayed during the “3 minutes ST”^{*} state period.
 - Start the operation and then press the TEST RUN button on the remote controller.
 - Press the MANUAL AUTO button on the indoor unit for 10 seconds or more.

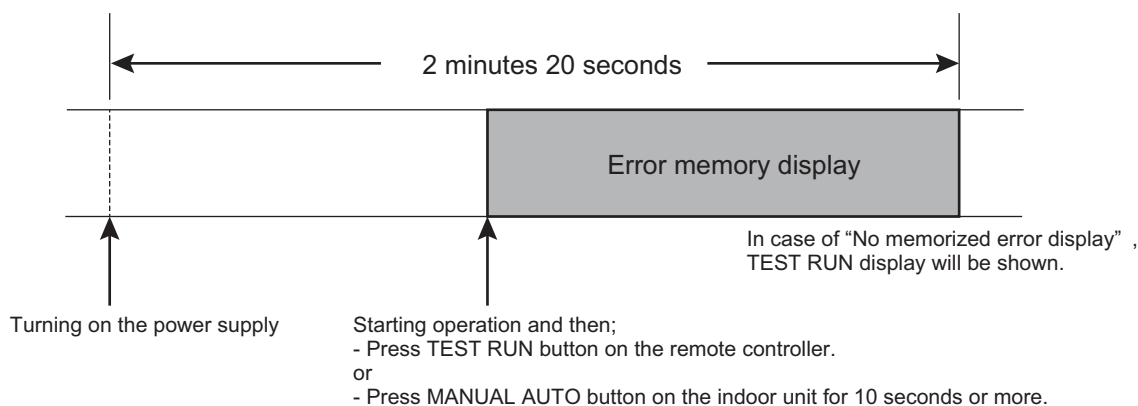

*: The “3 minutes ST” period lasts 2 minutes and 20 seconds after turning on the power supply.

1-2. How to erase the error memory

The error memory can be erased in one of the following two methods.

- Manual erase: Pressing the MANUAL AUTO button on the indoor unit while the “Error memory display” is being shown. (Short beep emits for about 3 seconds.)
- Automatic erase: After continuing the normal operation of the air conditioner without error for 2 hours or longer after displaying the error memory as described in [How to check the error memory](#). (Except FAN operation mode.)

1-3. Error code table (Wired remote controller)

The operation, timer, and economy indicators operate according to the error contents.
For confirmation of the error contents, refer the flashing pattern as follows.

Error contents	Wired remote controller display
E: 11.X. Serial communication error (Serial reverse transfer error) (Outdoor unit)	11
E: 11.X. Serial communication error (Serial forward transfer error) (Indoor unit)	11
E: 12.X. Wired remote controller communication error (Indoor unit)	12
E: 15.X. Automatic air flow adjustment error (Indoor unit)	15
E: 18.X. External communication error (Indoor unit)	18
E: 23.X. Combination error (Outdoor unit)	23
E: 26.X. Address setting error in wired remote controller (Indoor unit)	26
E: 29.X. Connected unit number error (Indoor unit)	29
E: 32.X. Indoor unit main PCB error (Indoor unit)	32
E: 33.X. Indoor unit motor electricity consumption detection error (Indoor unit)	33
E: 35.X. MANUAL AUTO button error (Indoor unit)	35
E: 39.X. Indoor unit power supply error for fan motor (Indoor unit)	39
E: 3A.X. Indoor unit communication circuit error (Indoor unit)	3A
E: 41.X. Room temperature sensor error (Indoor unit)	41
E: 42.X. Indoor unit heat exchanger sensor error (Indoor unit)	42
E: 44.X. Human sensor error	44
E: 51.X. Indoor unit fan motor error (Indoor unit)	51
E: 53.X. Drain pump error (Indoor unit)	53
E: 62.X. Outdoor unit main PCB error (Outdoor unit)	62
E: 63.X. Inverter error (Outdoor unit)	63
E: 64.X. PFC circuit error (Outdoor unit)	64
E: 65.X. IPM error (Outdoor unit)	65
E: 71.X. Discharge thermistor error (Outdoor unit)	71
E: 73.X. Outdoor unit heat exchanger thermistor error (Outdoor unit)	73
E: 74.X. Outdoor temperature thermistor error (Outdoor unit)	74
E: 84.X. Current sensor error (Outdoor unit)	84
E: 94.X. Trip detection (Outdoor unit)	94
E: 95.X. Compressor motor control error (Outdoor unit)	95
E: 97.X. Outdoor unit fan motor error (Outdoor unit)	97
E: 99.X. 4-way valve error (Outdoor unit)	99
E: A1.X. Discharge temperature error (Outdoor unit)	A1

2. Troubleshooting with error code

2-1. E: 11.X. Serial communication error (Serial reverse transfer error) (Outdoor unit)

Indicator	Wired remote controller	Error code	E: 11
Detective actuator	Outdoor unit	Main PCB	When the indoor unit cannot receive the serial signal from outdoor unit more than 2 minutes after power on, or the indoor unit cannot receive the serial signal more than 15 seconds during normal operation.
		Fan motor	
Forecast of cause			Connection failure
			External cause
			Main PCB failure
			Outdoor unit fan motor failure

Check point 1. Reset the power and operate

Does error indication show again?

→ If no, go to "Check point 1-2".



Check point 2. Check connection

Check any loose or removed connection line of indoor unit and outdoor unit.

Check connection condition is control unit. (If there is loose connector, open cable or mis-wiring.)

→ If there is an abnormal condition, correct it by referring to the installation manual or the "DESIGN & TECHNICAL MANUAL".



Check point 3. Check the voltage of power supply

Check the voltage of power supply

Check if AC 187 V (AC 208 V -10%) to AC 253 V (AC 230 V +10%) appears at outdoor unit terminal L1—L2.

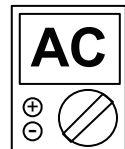

Check point 4. Check serial signal (Reverse transfer signal)

Check serial signal (Reverse transfer signal)

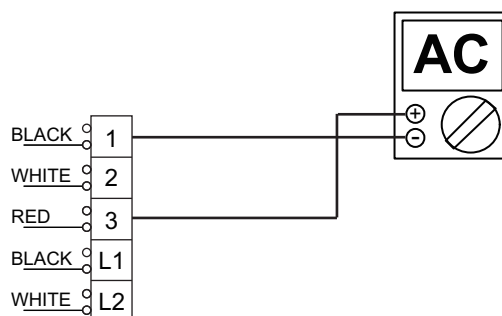

- Check if indicated value swings between AC 90 V and AC 270 V at the outdoor unit terminal 1—3.
- If it is abnormal, check the parts below.
 - Outdoor unit fan motor in "[Service parts information](#)" on page 03-47
- If outdoor fan motor is abnormal, replace outdoor unit fan motor and main PCB.
- If the checked parts are normal, replace the main PCB.



End

Check point 1-2. Check external cause such as noise

- Check the complete insulation of the grounding.
- Check if there is any equipment that causes harmonic wave near the power cable (Neon light bulb or any electronic equipment which causes harmonic wave).



End

2-2. E: 11.X. Serial communication error (Serial forward transfer error) (Indoor unit)

Indicator	Wired remote controller	Error code	E: 11
Detective actuator	Indoor unit	Main PCB	When the outdoor unit cannot properly receive the serial signal from indoor unit for 10 seconds or more.
		Fan motor	
	Outdoor unit	Main PCB	
Forecast of cause			Connection failure
			External cause
			Main PCB failure

Check point 1. Reset the power and operate

Does error indication show again?

→ If no, go to "Check point 1-2".



Check point 2. Check connection

Check any loose or removed connection line of indoor unit and outdoor unit.

→ If there is an abnormal condition, correct it by referring to the installation manual or the "DESIGN & TECHNICAL MANUAL".

Check connection condition is control unit. (If there is loose connector, open cable or mis-wiring.)



Check point 3. Check the voltage of power supply

Check the voltage of power supply

Check if AC 187 V (AC 208 V -10%) to AC 253 V (AC 230 V +10%) appears at outdoor unit terminal L1—L2.

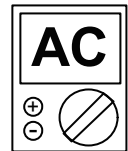

Check point 4. Check serial signal (Forward transfer signal)

Check serial signal (Forward transfer signal)

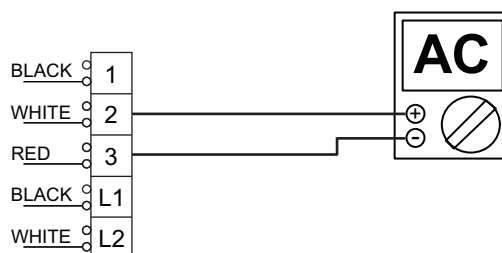

- Check if indicated value swings between AC 30 V and AC 130 V at outdoor unit terminal 2—3.
- If it is abnormal, replace main PCB.



End

Check point 1-2. Check external cause such as noise

- Check if the ground connection is proper.
- Check if there is any equipment that causes harmonic wave near the power cable (Neon light bulb or any electronic equipment which causes harmonic wave).



End

2-3. E: 12.X. Wired remote controller communication error (Indoor unit)

Indicator	Wired remote controller	Error code	E: 12
Detective actuator	Indoor unit	Main PCB	When the indoor unit cannot receive the signal from wired remote controller more than following time during normal operation. <ul style="list-style-type: none"> • 3-wire type: 1 minute • 2-wire type: 2.5 minutes
	Wired remote control		
Forecast of cause			Terminal connection abnormal
			Wired remote control failure
			Main PCB failure

Check point 1. Check the connection of terminal

After turning off the power, check & correct the followings.

- Check the connection of terminal between wired remote controller and indoor unit, and check if there is a disconnection of the cable.



Check Point 1-2 : Check Wired remote controller and main PCB

Check voltage at CN14 of main PCB.
(Power supply to the remote controller)
Upon correcting the removed connector or mis-wiring, reset the power.



- If it is DC 12 V, remote controller is failure. (Main PCB is normal)
 - Replace remote control
- If it is DC 0 V, main PCB is failure. (Check remote controller once again)
 - Replace main PCB



End

Check Point 2 : Wire installation wrong remote controller group setting

- Wrong wire connection in remote controller group (Please refer to the installation manual)
- The number of connecting indoor unit and remote controller in one remote controller group were less than 32 units.



Check Point 2-1 : Check Indoor unit main PCB

- Check if main PCB damage
- Change main PCB and check the error after setting remote controller address



End

2-4. E: 15.X. Automatic air flow adjustment error (Indoor unit)

Indicator	Wired remote controller	Error code	E: 15
Detective actuator	Indoor unit	Main PCB	<ul style="list-style-type: none"> On automatic airflow adjustment operation, when the fan speed other than 0rpm is detected at the 0rpm operation. On automatic airflow adjustment operation, when the fan speed is not reach the target speed, after 2 minutes from the fan started. On automatic airflow adjustment operation operation, when the 750 W of input power is detected.
Forecast of cause			Fan rotation failure
			Fan motor winding open
			Indoor unit main PCB

Check point 1. Check the rotation of fan

Rotate the fan by hand when the operation is off. (Check if fan is caught, drop off or locked motor)
→ If fan or bearing is abnormal, replace it.



Check point 2. Check ambient temperature around the motor

Check excessively high temperature around the motor. (If there is any surrounding equipment that causes heat.)
→ Upon the temperature coming down, restart operation.



Check point 3. Check indoor unit fan motor

Check indoor unit fan motor. (Refer to indoor unit fan motor in "[Service parts information](#)" on page 03-47.)
→ If indoor unit fan motor is abnormal, replace it.



Check point 4. Replace main PCB

If check point 1-3 does not improve the symptom, change main PCB.



End

2-5. E: 18.X. External communication error (Indoor unit)

Indicator	Wired remote controller	Error code	E: 18
Detective actuator	Indoor unit	External communication error	After receiving a signal from the external input and output PCB, the same signal has not been received for 15 seconds.
Forecast of cause			Connection failure
			External input and output PCB failure
			Main PCB

Check point 1. Check the connection

- Check any loose or removed connection between the main PCB to the external input and output PCB.
-> If there is an abnormal condition, correct it by refer to the installation manual or the "DESIGN & TECHNICAL MANUAL".
- Check the connection condition on the external input and output PCB and the main PCB (If there is loose connector, open cable or mis-wiring.)



Check point 2. Replace the external input and output PCB

If check point 1 do not improve the symptom, change external input and output PCB.



Check point 3. Replace the main PCB

If check point 2 do not improve the symptom, replace the main PCB.



End

2-6. E: 23.X. Combination error (Outdoor unit)

Indicator	Wired remote controller	Error code	E: 23
Detective actuator	Indoor unit	The outdoor unit receives the serial signal of applied refrigerant information from indoor unit.	
Forecast of cause	Incorrect indoor unit is selected.		

Check point 1. Check the type of indoor unit

- Check the type of the connected indoor unit.
-> If there is an abnormal condition, correct it by refer to the installation manual or the "DESIGN & TECHNICAL MANAL".



Check point 2. Replace the main PCB

If check point 1 do not improve the symptom, replace the main PCB of the outdoor unit.



End

2-7. E: 26.X. Address setting error in wired remote controller (Indoor unit)

Indicator	Wired remote controller	Error code	E: 26
Detective actuator	Wired remote controller (2-wire)	Indoor unit controller PCB	<ul style="list-style-type: none"> When the address number set by auto setting and manual setting are mixed in one remote controller group When the duplicated address number exists in one remote controller group
Forecast of cause			Wrong wiring of remote controller group
			Wrong remote controller address setting
			Indoor unit main PCB failure
			Remote controller failure

Check point 1. Wire installation

- Check the wire connection in the remote controller group (For installation method, refer to installation manual)
-> If there is an abnormal condition, correct it by refer to the installation manual or the "DESIGN & TECHNICAL MANUAL".



Check point 2. Wrong remote controller group setting

- The given address number by auto setting (00) and the manual set number (except 00) are not existing in one remote controller group.
- The remote controller address setting by UI is not existing same address.
- The duplicate address number is not existing in one remote controller group.



Check point 3. Check indoor unit main PCB

- Check if main PCB is damaged.
- Change main PCB and check the error after setting remote controller address.



End

2-8. E: 29.X. Connected unit number error (Indoor unit)

Indicator	Wired remote controller	Error code	E: 29
Detective actuator	Wired remote controller (2-wire)	When the number of the connected indoor unit exceeds the limitation.	
	Indoor unit main PCB		
Forecast of cause		Wrong wiring of indoor unit or remote controller	
		Number of indoor unit or remote controller in remote controller group	
		Indoor unit main PCB failure	

Check point 1. Wire installation

- Wrong number of connected indoor unit
-> If there is an abnormal condition, correct it by refer to the installation manual or the "DESIGN & TECHNICAL MANUAL".



Check point 2. Check indoor unit main PCB

- Check if main PCB is damaged.
- Change main PCB and check the error after setting remote controller address.



End

2-9. E: 32.X. Indoor unit main PCB error (Indoor unit)

Indicator	Wired remote controller	Error code	E: 32
Detective actuator	Indoor unit	main PCB	When power is on and there is some below case. 1. When model information of EEPROM is incorrect. 2. When the access to EEPROM failed.
Forecast of cause			External cause
			Defective connection of electrical components
			Main PCB failure

Check point 1. Reset power supply and operate

Does error indication show again?

→ If no, go to "Check point 1-2".



Check point 2. Check Indoor unit electrical components

- Check all connectors. (loose connector or incorrect wiring)
- Check any shortage or corrosion on PCB.



Check point 3. Replace the main PCB

Replace the main PCB.



End

Check point 1-2. Check external cause such as noise

- Check if the ground connection is proper.
- Check if there is any equipment that causes harmonic wave near the power cable (Neon light bulb or any electronic equipment which causes harmonic wave).



End

NOTE: EEPROM

EEPROM (Electrically Erasable and Programmable Read Only Memory) is a non-volatile memory which keeps memorized information even if the power is turned off. It can change the contents electronically. To change the contents, it uses higher voltage than normal, and it cannot change a partial contents. (Rewriting shall be done upon erasing the all contents.) There is a limit in a number of rewriting.

2-10. E: 33.X. Indoor unit motor electricity consumption detection error (Indoor unit)

Indicator	Wired remote controller	Error code	E: 33
Detective actuator	Indoor unit motor electricity consumption detection		When the voltage value or the current value of the motor go beyond the limits
Forecast of cause			Fan motor failure
			Main PCB failure

Check point 1. Check the rotation of fan

Rotate the fan by hand when the operation is off. (Check if fan is caught, drop off or locked motor)
→ If fan or bearing is abnormal, replace it.



Check point 2. Check ambient temperature around the motor

Check excessively high temperature around the motor. (If there is any surrounding equipment that causes heat.)
→ Upon the temperature coming down, restart operation.



Check point 3. Check indoor unit fan motor

Check indoor unit fan motor. (Refer to indoor unit fan motor in "[Service parts information](#)" on page 03-47.)
→ If indoor unit fan motor is abnormal, replace it.



Check point 4. Replace the main PCB

If check point 1-3 does not improve the symptom, replace the main PCB.



End

2-11. E: 35.X. MANUAL AUTO button error (Indoor unit)

Indicator	Wired remote controller	Error code	E: 35
Detective actuator	Indoor unit controller PCB		When the MANUAL AUTO button becomes on for consecutive 60 or more seconds.
	Indicator PCB		
	Manual auto switch		
Forecast of cause			MANUAL AUTO button failure
			Controller PCB and indicator PCB failure

Check point 1. Check the MANUAL AUTO button

- Check if MANUAL AUTO button is kept pressed.
- Check ON/OFF switching operation by using a meter.

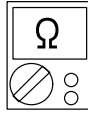

If MANUAL AUTO button is disabled (ON/OFF switching), replace it.



Check point 2. Replace the main PCB and indicator PCB

If Check Point 1 does not improve the symptom, replace the main PCB and indicator PCB.



End

2-12. E: 39.X. Indoor unit power supply error for fan motor (Indoor unit)

Indicator	Wired remote controller	Error code	E: 39
Detective actuator	Indoor unit main PCB		<ul style="list-style-type: none"> When a momentary power cut off When do not start fan motor
Forecast of cause			External cause
			Connector connection failure
			Main PCB failure

Check point 1. Check external cause at indoor and outdoor (Voltage drop or Noise)

- Instant drop: Check if there is a large load electric apparatus in the same circuit.
- Momentary power failure: Check if there is a defective contact or leak current in the power supply circuit.
- Noise: Check if there is any equipment causing harmonic wave near electric line. (Neon bulb or electric equipment that may cause harmonic wave)
Check the complete insulation of grounding.



Check point 2. Check connection of Connector

- Check if connector is removed.
- Check erroneous connection.
- Check if cable is open.

→ Upon correcting the removed connector or mis-wiring, reset the power.



Check point 3. Replace the main PCB

If check point 1 to 2 do not improve the symptom, replace the main PCB.



End

2-13. E: 3A.X. Indoor unit communication circuit error (Indoor unit)

Indicator	Wired remote controller	Error code	E: 3A
Detective actuator	Wired remote controller (2-wire)	When the indoor unit detects the configuration of remote controller group abnormal or the indoor unit detects lack of the primary remote controller	
	Indoor unit controller PCB circuit		
Forecast of cause			Terminal connection abnormal
			Wired remote controller failure
			Indoor unit main PCB defective

Check point 1. Check the connection of terminal

- After turning off the power supply, check and correct as follows:
Indoor unit: Check the connection of the terminal between the remote controller and indoor unit, or between indoor units and check if there is a disconnection or short of the cable.



Check point 2. Check the indoor unit main PCB

- Check terminal voltage of CN14 of main PCB (Power supply for remote)
If terminal voltage is DC 12 V, remote controller failure (Control PCB is OK).
If terminal voltage is DC 0 V, main PCB failure (Remote controller is OK).



NOTE: In case of re-installation is done due to removed connector or incorrect wiring, turn on the power again.



End

Tip

Depending on the connected remote controller type, following setting is required:

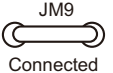
Connected remote controller	DIP switch	Jumper (JM9)
2-wire type	 Factory setting: 2WIRE	 Disconnected
3-wire type	 Factory setting: 3WIRE	 Connected (Factory setting)

- 2-wire type remote main PCB**
If the communication PCB is not connected and JM9 is disconnected, 3A error is displayed.
If the communication PCB is connected and JM9 is connected, the 2-wire remote controller does not work.
If the DIP switch is 3-wire side, the 2-wire type remote controller does not work.
- 3-wire type remote main PCB**
If the DIP switch is 2-wire side, the 3-wire type remote controller does not work.

2-14. E: 41.X. Room temperature sensor error (Indoor unit)

Indicator	Wired remote controller	Error code	E: 41
Detective actuator	Indoor unit main PCB	Room temperature thermistor is open or short is detected always.	
	Room temperature thermistor		
Forecast of cause			Connector failure
			Thermistor failure
			Main PCB failure

Check point 1. Check connection of connector

- Check if connector is loose or removed.
- Check erroneous connection.
- Check if thermistor cable is open

-> Reset power when reinstalling due to removed connector or incorrect wiring.



Check point 2. Remove connector and check thermistor resistance value

- For the room thermistor resistance value, refer to "[Thermistor resistance values](#)" on page 03-53.
- If thermistor is either open or shorted, replace it and reset the power.

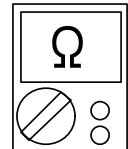

Check point 3. Check voltage of main PCB

Make sure circuit diagram of each indoor unit and check terminal voltage at thermistor (DC 5.0 V).

NOTE: For details of thermistor connector, refer to "[Wiring diagrams](#)" in Chapter 2. TECHNICAL DATA AND PARTS LIST on page 02-13.

(CN8)

If the voltage does not appear, replace main PCB.

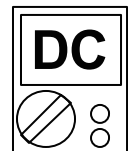

End

2-15. E: 42.X. Indoor unit heat exchanger sensor error (Indoor unit)

Indicator	Wired remote controller	Error code	E: 42
Detective actuator	Indoor unit main PCB	Heat exchanger temperature thermistor	When heat exchanger temperature thermistor open or short circuit is detected.
Forecast of cause			Connector connection failure
			Thermistor failure
			Main PCB failure

Check point 1. Check connection of connector

- Check if connector is loose or removed.
- Check erroneous connection.
- Check if thermistor cable is open

-> Reset power when reinstalling due to removed connector or incorrect wiring.



Check point 2. Remove connector and check thermistor resistance value

- For the heat exchanger thermistor resistance value, refer to "[Thermistor resistance values](#)" on page 03-53.
- If thermistor is either open or shorted, replace it and reset the power.

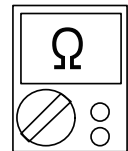

Check point 3. Check voltage of main PCB

Make sure circuit diagram of each indoor unit and check terminal voltage at thermistor (DC 5.0 V).

NOTE: For details of thermistor connector, refer to "[Wiring diagrams](#)" in Chapter 2. TECHNICAL DATA AND PARTS LIST on page 02-13.
(CN32)

If the voltage does not appear, replace main PCB.



End

2-16. E: 44.X. Human sensor error

Indicator	Wired remote controller	Error code	E: 44
Detective actuator	Indoor unit main PCB		1. Detect the open condition of the sensor. 2. When signal from sensor is "L" (0 V) for more than 10 min.
Forecast of cause			Connector connection failure
			Sensor failure
			Main PCB failure

Check point 1. Check the connector connection and cable open

- Check if connector is loose or removed.
- Check erroneous connection.
- Check if sensor cable is open
→ Reset power when reinstalling due to removed connector or incorrect wiring.



Check point 2. Check the conduction or voltage

- **Conduction check (sensor connections error)**
Disconnect the sensor and check the 4—5pin on sensor connector.
→ With conduction: Sensor failure
→ Without conduction: Main PCB failure
- **Voltage check (sensor signal error)**
Disconnect the sensor and check the voltage of 1pin of the CN67 on the main PCB.
→ 5 V: Sensor failure
→ Other than 5 V: Main PCB failure



End

2-17. E: 51.X. Indoor unit fan motor error (Indoor unit)

Indicator	Wired remote controller	Error code	E: 51
Detective actuator	Indoor unit	main PCB	When the actual rotation number of the indoor unit fan motor is below 1/3 of the target rotation number continuously for more than 56 seconds.
		Fan motor	
Forecast of cause			Fan rotation failure
			Fan motor winding open
			Motor protection by surrounding temperature rise
			Control PCB failure
			Indoor unit fan motor failure

Check point 1. Check rotation of fan

Rotate the fan by hand when operation is off. (Check if fan is caught, dropped off or locked motor)
→ If fan or bearing is abnormal, replace it.



Check point 2. Check ambient temperature around motor

Check excessively high temperature around the motor. (If there is any surrounding equipment that causes heat)
→ Upon the temperature coming down, restart operation.



Check point 3. Check indoor unit fan motor

Check Indoor unit fan motor. (Refer to indoor unit fan motor in "[Service parts information](#)" on page 03-47.)
→ If Indoor unit fan motor is abnormal, replace Indoor unit fan motor.



Check point 4. Replace the main PCB

If Check Point 1 to 3 do not improve the symptom, replace the main PCB.



End

2-18. E: 53.X. Drain pump error (Indoor unit)

Indicator	Wired remote controller	Error code	E: 53
Detective actuator	Indoor unit main PCB Float switch		When Float switch is ON for more than 3 minutes.
Forecast of cause			Float switch failure
			Shorted connector/wire failure
			Main PCB failure
			Drain pump failure
			Hose clogging

Check point 1. Check float switch

- Check operation of float switch. (any blocking by dust, etc.)
- Remove float switch and check ON/OFF switching operation by using a meter.

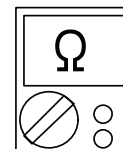

-> If float switch is abnormal, replace it.



Check point 2. Check connector and wire

Check loose contact of CN9 and shorted wire (pinched wire).
-> Replace float switch if the wire is abnormal



Check point 3. Check drain hose

Check drain hose.
-> If there is hose clogging. Please clear the clog.



Check point 4. Replace drain pump

If check point 1 to 3 do not improve the symptom, replace drain pump.



Check point 5. Replace main PCB

If check point 4 do not improve the symptom, replace main PCB.



End

2-19. E: 62.X. Outdoor unit main PCB error (Outdoor unit)

Indicator	Wired remote controller	Error code	E: 62
Detective actuator	Outdoor unit	Main PCB	Access to EEPROM failed due to some cause after outdoor unit started.
Forecast of cause			External cause (Noise, temporary open, voltage drop) Main PCB failure

Check point 1. Reset power supply and operate

Does error indication show again?

If no, go to "Check point 1-2".



Check point 2. Replace the main PCB

Replace the main PCB.



End

Check point 1-2. Check external cause

- Check if temporary voltage drop was not generated.
- Check if momentary open was not generated.
- Check if ground is connection correctly or there are no related cables near the power line.



End

2-20. E: 63.X. Inverter error (Outdoor unit)

Indicator	Wired remote controller	Error code	E: 63
Detective actuator	Outdoor unit	Inverter PCB	Error information received from inverter PCB
Forecast of cause			External cause
			Power supply to inverter PCB wiring disconnection or open
			Inverter PCB failure

Check point 1. Turn the power on again?

Error displayed again?

If no, go to "[Check point 1-2](#)".



Check point 2. Check the wiring (power supply to inverter PCB)

- Connector and wiring connection state check
- Cable open check



Check point 3. Replace inverter PCB

Replace inverter PCB



End

Check point 1-2. Check external cause

- Check if temporary voltage drop was not generated.
- Check if momentary open was not generated.
- Check if ground is connection correctly or there are no related cables near the power line.



End

2-21. E: 64.X. PFC circuit error (Outdoor unit)

Indicator	Wired remote controller	Error code	E: 64
Detective actuator	Outdoor unit	Main PCB	<ul style="list-style-type: none"> When inverter input DC voltage is higher than 415 V for over 3 seconds, the compressor stops. If the same operation is repeated 5 times, the compressor stops permanently.
Forecast of cause			External cause
			Connector connection failure
			Main PCB failure

Check point 1. Check external cause at indoor and outdoor (Voltage drop or Noise)

- Instant drop: Check if there is a large load electric apparatus in the same circuit.
- Momentary power failure: Check if there is a defective contact or leak current in the power supply circuit.
- Noise: Check if there is any equipment causing harmonic wave near electric line. (Neon bulb or electric equipment that may cause harmonic wave)
Check the complete insulation of grounding.



Check point 2. Check connection of Connector

- Check if connector is removed.
- Check erroneous connection.
- Check if cable is open.

→ Upon correcting the removed connector or mis-wiring, reset the power.



Check point 3. Replace the main PCB

If check point 1 to 2 do not improve the symptom, replace the main PCB.



End

2-22. E: 65.X. IPM error (Outdoor unit)

Indicator	Wired remote controller	Error code	E: 65
Detective actuator	Outdoor unit	Main PCB	<ol style="list-style-type: none"> When more than normal operating current to IPM in main PCB flows, the compressor stops. After the compressor restarts, if the same operation is repeated within 40 seconds, the compressor stops again. If 1. and 2. repeats 5 times, the compressor stops permanently.
		Compressor	
Forecast of cause			Defective connection of electrical components
			Outdoor fan operation failure
			Outdoor heat exchanger clogged
			Compressor failure
			Main PCB failure

Check point 1. Check connections of outdoor unit electrical components

- Check if the terminal connection is loose.
- Check if connector is removed.
- Check erroneous connection.
- Check if cable is open.

→ Upon correcting the removed connector or mis-wiring, reset the power.



Check point 2. Check outdoor fan and heat exchanger

- Is there anything obstructing the air distribution circuit?
- Is there any clogging of outdoor heat exchanger?
- Is the fan rotating by hand when operation is off?

→ If the fan motor is locked, replace it.



Check point 3. Check outdoor fan

Check outdoor fan motor. (Refer to "[E: 97.X. Outdoor unit fan motor error \(Outdoor unit\)](#)" on page 03-34.)

→ If the fan motor is failure, replace it.



Check point 4. Check compressor

Check compressor. (Refer to inverter compressor in "[Service parts information](#)".)



Check point 5. Replace main PCB

If Check point 1 to 4 do not improve the symptom, change main PCB.



End

2-23. E: 71.X. Discharge thermistor error (Outdoor unit)

Indicator	Wired remote controller	Error code	E: 71
Detective actuator	Outdoor unit main PCB	When discharge pipe temperature thermistor open or short circuit is detected at power on or while running the compressor	
	Discharge pipe temperature thermistor		
Forecast of cause			Connector failure
			Thermistor failure
			Main PCB failure

Check point 1. Check connection of connector

- Check if connector is loose or removed.
- Check erroneous connection.
- Check if thermistor cable is open

→ Reset power when reinstalling due to removed connector or incorrect wiring.



Check point 2. Remove connector and check thermistor resistance value

- For the discharge temperature thermistor resistance value, refer to "[Thermistor resistance values](#)" on page 03-53.
- If thermistor is either open or shorted, replace it and reset the power.

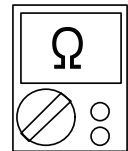

Check point 3. Check voltage of main PCB

Make sure circuit diagram of outdoor unit and check terminal voltage at thermistor (DC 5.0 V).

NOTE: For details of thermistor connector, refer to "[Wiring diagrams](#)" in Chapter 2. TECHNICAL DATA AND PARTS LIST on page 02-13.

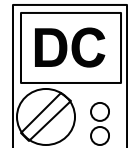

If the voltage does not appear, replace main PCB.



End

2-24. E: 73.X. Outdoor unit heat exchanger thermistor error (Outdoor unit)

Indicator	Wired remote controller	Error code	E: 73
Detective actuator	Outdoor unit main PCB	Heat exchanger temperature thermistor	When heat exchanger temperature thermistor open or short circuit is detected at power on or while running the compressor
	Heat exchanger temperature thermistor		
Forecast of cause			Connector failure
			Thermistor failure
			Main PCB failure

Check point 1. Check connection of connector

- Check if connector is loose or removed.
- Check erroneous connection.
- Check if thermistor cable is open

→ Reset power when reinstalling due to removed connector or incorrect wiring.



Check point 2. Remove connector and check thermistor resistance value

- For the outdoor unit heat exchanger thermistor resistance value, refer to "[Thermistor resistance values](#)" on page 03-53.
- If thermistor is either open or shorted, replace it and reset the power.

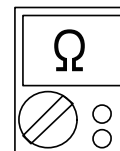

Check point 3. Check voltage of main PCB

Make sure circuit diagram of outdoor unit and check terminal voltage at thermistor (DC 5.0 V).

NOTE: For details of thermistor connector, refer to "[Wiring diagrams](#)" in Chapter 2. TECHNICAL DATA AND PARTS LIST on page 02-13.

If the voltage does not appear, replace main PCB.



End

2-25. E: 74.X. Outdoor temperature thermistor error (Outdoor unit)

Indicator	Wired remote controller	Error code	E: 74
Detective actuator	Outdoor unit main PCB	When outdoor temperature thermistor open or short circuit is detected at power on or while running the compressor	
	Outdoor temperature thermistor		
Forecast of cause			Connector failure
			Thermistor failure
			Main PCB failure

Check point 1. Check connection of connector

- Check if connector is loose or removed.
- Check erroneous connection.
- Check if thermistor cable is open

-> Reset power when reinstalling due to removed connector or incorrect wiring.



Check point 2. Remove connector and check thermistor resistance value

- For the outdoor temperature thermistor resistance value, refer to "[Thermistor resistance values](#)" on page 03-53.
- If thermistor is either open or shorted, replace it and reset the power.

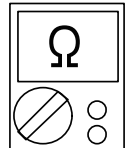

Check point 3. Check voltage of main PCB

Make sure circuit diagram of outdoor unit and check terminal voltage at thermistor (DC 5.0 V).

NOTE: For details of thermistor connector, refer to "[Wiring diagrams](#)" in Chapter 2. TECHNICAL DATA AND PARTS LIST on page 02-13.

(P5)

If the voltage does not appear, replace main PCB.



End

2-26. E: 84.X. Current sensor error (Outdoor unit)

Indicator	Wired remote controller	Error code	E: 84
Detective actuator	Outdoor unit	main PCB	When input current sensor has detected 0 A, while inverter compressor is operating at higher than 56 rps, after 1 minute upon starting the compressor. (Except during the defrost operation)
Forecast of cause			Defective connection of electrical components
			External cause
			Main PCB failure

Check point 1. Reset power supply and operate

Does error indication show again?

If no, go to "Check point 1-2".



Check point 2. Check connections of outdoor unit electrical components

- Check if the terminal connection is loose.
- Check if connector is removed.
- Check erroneous connection.
- Check if cable is open.

Upon correcting the removed connector or miswiring, reset the power.



Check point 3. Replace the main PCB

If Check point 1, 2 do not improve the symptom, replace the main PCB.



End

Check point 1-2. Check external cause at Indoor and Outdoor (Voltage drop or Noise)

- Instant drop: Check if there is a large load electric apparatus in the same circuit.
- Momentary power failure: Check if there is a defective contact or leak current in the power supply circuit.
- Noise: Check if there is any equipment causing harmonic wave near electric line. (Neon bulb or electric equipment that may cause harmonic wave)
Check the complete insulation of grounding.



End

2-27. E: 94.X. Trip detection (Outdoor unit)

Indicator	Wired remote controller	Error code	E: 94
Detective actuator	Outdoor unit	Main PCB	Protection stop by over-current generation after inverter compressor start processing completed generated consecutively 10 times. NOTE: The number of generations is reset when the compressor starts up.
		Compressor	
Forecast of cause			Outdoor unit fan operation defective, foreign matter on heat-exchanger, excessive rise of ambient temperature
			Main PCB failure
			Inverter compressor failure (lock, winding short)

Check point 1. Check the outdoor unit fan operation, heat-exchanger, ambient temperature

- No obstructions in air passages?
- Heat exchange fins clogged
- Outdoor unit fan motor check
- Ambient temperature not raised by the effect of other heat sources?
- Discharged air not sucked in?



Check point 2. Replace the main PCB

If Check point 1 do not improve the symptom, replace the main PCB.



Check point 3. Replace compressor

If Check point 2 do not improve the symptom, change compressor.



End

2-28. E: 95.X. Compressor motor control error (Outdoor unit)

Indicator	Wired remote controller	Error code	E: 95
Detective actuator	Outdoor unit	Main PCB	<ol style="list-style-type: none"> When running the compressor, if the detected rotor location is out of phase with actual rotor location more than 90°, the compressor stops. After the compressor restarts, if the same operation is repeated within 40 seconds, the compressor stops again. If 1. and 2. repeats 5 times, the compressor stops permanently.
		Compressor	
Forecast of cause			Defective connection of electrical components
			Main PCB failure
			Compressor failure

Check point 1. Check Noise from Compressor

Turn on Power and check operation noise.
→ If an abnormal noise show, replace compressor.



Check point 2. Check connection of around the compressor components

For compressor terminal, main PCB

- Check if connector is removed.
- Check erroneous connection.
- Check if cable is open. (Refer to inverter compressor in "[Service parts information](#)" on page 03-47.)

→ Upon correcting the removed connector or mis-wiring, reset the power.



Check point 3. Replace the main PCB

If Check point 1, 2 do not improve the symptom, replace the main PCB.



Check point 4. Replace compressor

If Check point 3 do not improve the symptom, change compressor.



End

2-29. E: 97.X. Outdoor unit fan motor error (Outdoor unit)

Indicator	Wired remote controller	Error code	E: 97
Detective actuator	Outdoor unit	Main PCB	<ol style="list-style-type: none"> When outdoor fan rotation speed is less than 100 rpm in 20 seconds after fan motor starts, fan motor stops. After fan motor restarts, if the same operation within 60 seconds is repeated 3 times in a row, compressor and fan motor stops. If 1. and 2. repeats 5 times in a row, compressor and fan motor stops permanently.
		Fan motor	
Forecast of cause			Fan rotation failure
			Motor protection by surrounding temperature rise
			Main PCB failure
			Outdoor unit fan motor

Check point 1. Check rotation of fan

Rotate the fan by hand when operation is off. (Check if fan is caught, dropped off or locked motor)
→ If fan or bearing is abnormal, replace it.



Check point 2. Check ambient temperature around motor

Check excessively high temperature around the motor. (If there is any surrounding equipment that causes heat)
→ Upon the temperature coming down, restart operation.



Check point 3. Check outdoor unit fan motor

Check outdoor unit fan motor. (Refer to outdoor unit fan motor in "[Service parts information](#)" on page 03-47.)
→ If outdoor unit fan motor is abnormal, replace outdoor unit fan motor and main PCB.



Check point 4. Check output voltage of main PCB

Check outdoor unit circuit diagram and the voltage. (Measure at main PCB side connector)

NOTE: For details of wiring diagram, refer to "[Wiring diagrams](#)" in Chapter 2. TECHNICAL DATA AND PARTS LIST on page 02-13.



Read wire	DC voltage
Red—Black	140 V to 280 V ±10 %
White—Black	15 ±1.5 V

-> If the voltage is not correct, replace Main PCB.



End

2-30. E: 99.X. 4-way valve error (Outdoor unit)

Indicator	Wired remote controller	Error code	E: 99
Detective actuator	Indoor unit	main PCB	<p>When the indoor heat exchanger temperature is compared with the room temperature, and either following condition is detected continuously two times, the compressor stops.</p> <p>Indoor heat exchanger temp. - Room temp. > 20 °F (10 °C) (Cooling or Dry operation)</p> <p>Indoor heat exchanger temp. - Room temp. < -20 °F (-10 °C) (Heating operation)</p> <p>If the same operation is repeated 5 times, the compressor stops permanently.</p>
	Heat exchanger temperature thermistor		
	Room temperature thermistor		
	4-way valve		
Forecast of cause			Connector connection failure
			Thermistor failure
			Coil failure
			4-way valve failure
			Main PCB failure

Check point 1. Check connection of connector

- Check if connector is removed.
- Check erroneous connection.
- Check if thermistor cable is open.

→ Upon correcting the removed connector or mis-wiring, reset the power.



Check point 2. Check each thermistor

- Isn't it fallen off the holder?
- Is there a cable pinched?

Check characteristics of room thermistor and indoor unit heat exchanger thermistor.

For the thermistor resistance value, refer to "[Thermistor resistance values](#)" on page 03-53.

→ If defective, replace the thermistor.



Check point 3. Check the solenoid coil and 4-way valve

- **Solenoid coil**
Remove P60 from PCB and check the resistance value of coil. Resistance value is about 1.97 k Ω (at 68 °F [20 °C]).
→ If it is open or abnormal resistance value, replace solenoid coil.
- **4-way valve**
Check each piping temperature, and the location of the valve by the temperature difference.
If the value location is not proper, replace 4-way valve.

**Check point 4. Check the voltage of 4-way valve**

Check the voltage P60 of Main PCB.

→ Check if AC 187 V (AC 208 V -10%) to AC 253 V (AC 230 V +10%) appears at P60 of Main PCB.

- **Heating operation**
→ If it is not voltage, Replace Main PCB.
- **Cooling operation**
→ If it is voltage, Replace Main PCB.

**Check point 5. Replace the main PCB**

If Check Point 1 to 4 do not improve the symptom, replace the main PCB.



End

2-31. E: A1.X. Discharge temperature error (Outdoor unit)

Indicator	Wired remote controller	Error code	E: A1
Detective actuator	Outdoor unit main PCB		Protection stop by discharge temperature ≥ 230 °F (110 °C) during compressor operation generated 2 times within 24 hours.
	Discharge temperature thermistor		
Forecast of cause			3-way valve not opened
			EEV or capillary tube defective, strainer clogged
			Outdoor unit operation failure, foreign matter on heat exchanger
			Discharge temperature thermistor failure
			Insufficient refrigerant
			Main PCB failure

Check point 1. Check if 3-way valve is open

If the 3-way valve is closed, open the 3-way valve and check operation.

NOTE: For cooling operation, check gas side of the 3-way valve.
For heating operation, check liquid side of the 3-way valve.



Check point 2. Check any of the electronic expansion valve (EEV), capillary tube, or strainer, or all

- Check if EEV open or there is a capillary tube defect.
Refer to outdoor unit Electronic Expansion Valve (EEV) or Capillary tube in "[Service parts information](#)" on page 03-47.
- Check the strainer clogging.



Check point 3. Check the outdoor unit fan and heat exchanger

- Check for foreign object at heat exchanger
- Check if fan can be rotated by hand.
- Check the motor. (Refer to outdoor unit fan motor in "[Service parts information](#)" on page 03-47.)



Check point 4. Check the discharge thermistor

The discharge temperature thermistor characteristics check. (Check by disconnecting thermistor from PCB.)

NOTE: For the characteristics of the thermistor, refer to "[Thermistor resistance values](#)" on page 03-53.



Check point 5. Check the refrigerant amount

Check the refrigerant leakage.



Check point 6. Replace the main PCB

If check point 1 to 5 do not improve the symptom, replace the main PCB.



End

3. Troubleshooting without error code

3-1. Indoor unit—No power

Forecast of cause	Power supply failure
	External cause
	Electrical components defective

Check point 1. Check installation condition

- Isn't the breaker down?
- Check loose or removed connection cable.

-> If abnormal condition is found, correct it by referring to the installation manual or the "DESIGN & TECHNICAL MANUAL".



Check point 2. Check external cause at indoor and outdoor (voltage drop or noise)

- Instant drop: Check if there is a large load electric apparatus in the same circuit.
- Momentary power failure: Check if there is a defective contact or leak current in the power supply circuit.
- Noise: Check if there is any equipment causing harmonic wave near electric line. (Neon bulb or electric equipment that may cause harmonic wave)
Check the complete insulation of grounding.



Check point 3. Check electrical components

Check the voltage of power supply.

Check if AC 187 to 253 V appears at outdoor unit terminal L1—L2.

-> If no, go to "[Check point 1](#)" and "[Check point 2](#)".



- Check fuse in filter PCB.
If fuse is open, check if the wiring between terminal and filter PCB is loose, and replace fuse.
- Check varistor in filter PCB.
If varistor is defective, there is a possibility of an abnormal power supply.
Check the correct power supply and replace varistor.
Upon checking the normal power supply, replace varistor.



End

3-2. Outdoor unit—No power

Forecast of cause	Power supply failure
	External cause
	Electrical components defective

Check point 1. Check installation condition

- Is the circuit breaker on or off?
- Check loose or removed connection cable.

→ If abnormal condition is found, correct it by referring to the installation manual or the "DESIGN & TECHNICAL MANUAL".



Check point 2. Check external cause at indoor and outdoor (voltage drop or noise)

- Instant drop: Check if there is a large load electric apparatus in the same circuit.
- Momentary power failure: Check if there is a defective contact or leak current in the power supply circuit.
- Noise: Check if there is any equipment causing harmonic wave near electric line. (Neon bulb or electric equipment that may cause harmonic wave)
Check the complete insulation of grounding.



Check point 3. Check electrical components

Check the voltage of power supply.

Check if AC 187 to 253 V appears at outdoor unit terminal L1—L2

→ If no, go to "[Check point 1](#)" and "[Check point 2](#)".

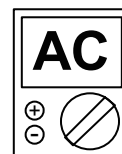

- Check fuse in main PCB.
If fuse is open, check if the wiring between terminal and main PCB is loose, and replace fuse.
- Check varistor in main PCB.
If varistor is defective, there is a possibility of an abnormal power supply. Check the correct power supply and replace varistor.
→ Upon checking the normal power supply, replace varistor.



Check point 4. Replace the main PCB

If check point 1 to 3 do not improve the symptom, replace the main PCB.



End

3-3. No operation (Power is on)

Forecast of cause	Setting/ Connection failure
	External cause
	Electrical components defective

Check point 1. Check indoor and outdoor installation condition

- Indoor unit:
 - Check incorrect wiring between indoor unit and remote controller.
 - Check if there is an open cable connection.
 - Are these indoor unit, outdoor unit, and remote controller suitable model names to connect?
- > If there is some abnormal condition, correct it by referring to the installation manual and "DESIGN & TECHNICAL MANUAL".



Turn off the power and check correct followings.

- Is there loose or removed communication line of indoor unit and outdoor unit?



Check point 2. Check external cause at indoor and outdoor (Voltage drop or Noise)

- Instant drop: Check if there is a large load electric apparatus in the same circuit.
- Momentary power failure: Check if there is a defective contact or leak current in the power supply circuit.
- Noise: Check if there is any equipment causing harmonic wave near electric line. (Neon bulb or electric equipment that may cause harmonic wave)
Check the complete insulation of grounding.



Check point 3. Check wired remote controller and controller PCB

Check voltage at CN14 of main PCB. (terminal 1—3).
(Power supply to remote controller)

- If it is DC 12 V, remote controller is failure. (The controller PCB is normal)
-> Replace remote controller.
- If it is DC 0 V, controller PCB is failure. (Check the remote controller once again)
-> Replace controller PCB.



Check point 4. Replace main PCB

If check point 1 to 3 do not improve the symptom, change main PCB.



End

3-4. No cooling/No heating

Forecast of cause	Indoor unit error
	Outdoor unit error
	Effect by surrounding environment
	Connection pipe/Connection wire failure
	Refrigeration cycle failure

Check point 1. Check Indoor unit

- Does Indoor unit fan run in the HIGH mode?
- Is air filter dirty?
- Is heat exchanger clogged?
- Check if energy save function is operated.



Check point 2. Check outdoor unit operation

- Check if outdoor unit is operating.
- Check any objects that obstruct the air flow route.
- Check if heat exchanger is clogged.
- Is the valve open?



Check point 3. Check site condition

- Is capacity of Indoor unit fitted to the room size?
- Any windows open or direct sunlight?



Check point 4. Check indoor/outdoor installation condition

- Check connection pipe (specified pipe length and pipe diameter?)
- Check any loose or removed communication line.

→ If there is an abnormal condition, correct it by referring to the installation manual or the "DESIGN & TECHNICAL MANUAL".



Check point 5. Check Refrigeration cycle

- Check if strainer is clogged (Refer to the figure below).
- Measure gas pressure, and if there is a leakage, correct it.
- Check if EEV open or there is a capillary tube defect.
Refer to outdoor unit Electronic Expansion Valve (EEV) or Capillary tube in "[Service parts information](#)" on page 03-47.
- Check compressor.
Refer to compressor in "[Service parts information](#)" on page 03-47.
Refer to inverter compressor in "[Service parts information](#)" on page 03-47.

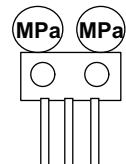

NOTE: When recharging the refrigerant, make sure to perform vacuuming, and recharge the specified amount.



End

NOTES:

- Strainer normally does not have temperature difference between inlet and outlet as shown below.

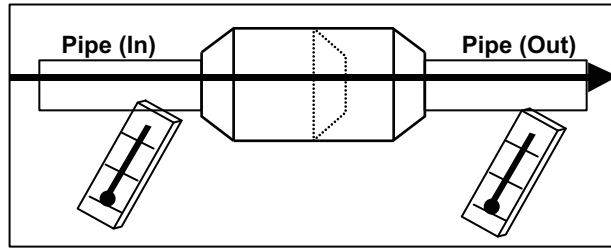

- If there is a difference like shown below, there is a possibility of inside clogged. In this case, replace the strainer.

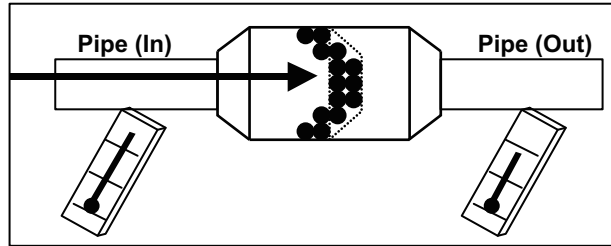

3-5. Abnormal noise

Forecast of cause	Abnormal installation (indoor unit/outdoor unit)
	Fan failure (indoor unit/outdoor unit)
	Compressor failure (outdoor)

Diagnosis method when abnormal noise is occurred

Abnormal noise is coming from Indoor unit.
(Check and correct followings)



- Is main unit installed in stable condition?
- Is the installation of air suction grille and front panel normal?



- Is fan broken or deformed?
- Is the screw of fan loose?
- Is there any object which obstruct the fan rotation?



End

Abnormal noise is coming from Outdoor unit.
(Check and correct followings)



- Is main unit installed in stable condition?
- Is fan guard installed normally?



- Is fan broken or deformed?
- Is the screw of fan loose?
- Is there any object which obstruct the fan rotation?



Check if vibration noise by loose bolt or contact noise of piping is happening.



Is compressor locked?

- Check Compressor
Refer to compressor and inverter compressor in "[Service parts information](#)" on page 03-47.



End

3-6. Water leaking

Forecast of cause

Erroneous installation

Drain hose failure

Diagnosis method when water leak occurs

- Is main unit installed in stable condition?
- Is main unit broken or deformed at the time of transportation or maintenance?



- Is drain hose connection loose?
- Is there a trap in drain hose?
- Is drain hose clogged?



Is fan rotating?



End

Diagnosis method when water is spitting out

Is the filter clogged?



Check gas pressure and correct it if there was a gas leak.

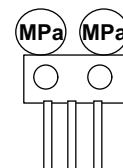

End

3-7. Louver operation abnormal

Forecast of cause	Connection failure
	Step motor failure
	Main PCB failure

Diagnosis method when louver operation abnormal is occurred

Check any loose or removed connection line of between main PCB to step motor.



- **All louver abnormal**
Replace the main PCB.
- **Some louver abnormal**
Replace the step motor.



End

4. Service parts information

4-1. Compressor

Diagnosis method of compressor (If outdoor unit LED displays error, refer to troubleshooting)

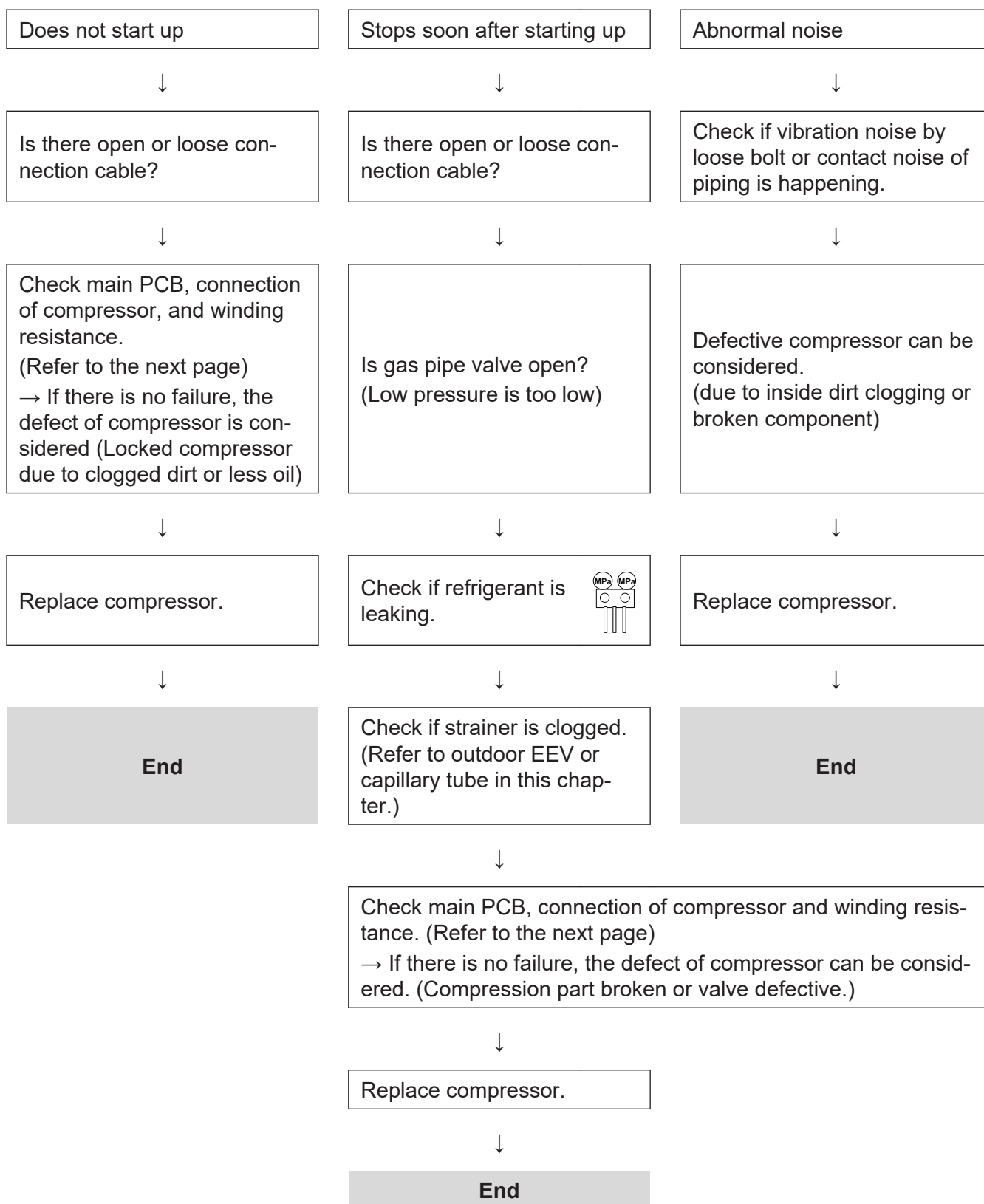

4-2. Inverter compressor

Check point 1. Check connection

Check terminal connection of compressor.
(loose or incorrect wiring)

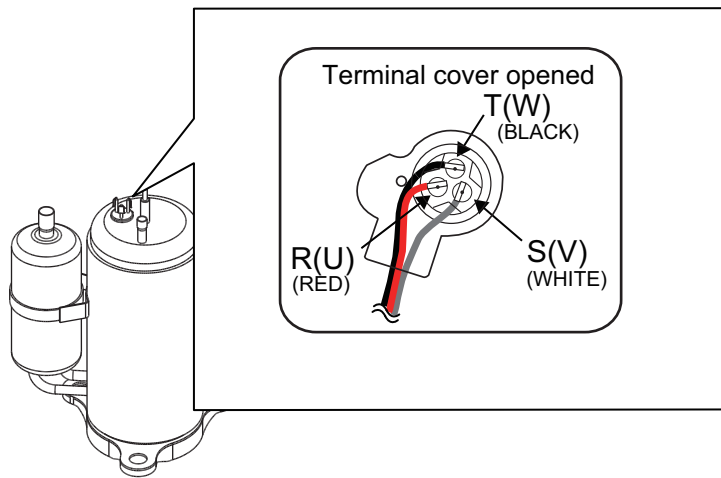

Check point 2. Check winding resistance

Check winding resistance of each terminal.

Resistance value: $1.916 \pm 8\% \Omega$ at 68°F (20°C)

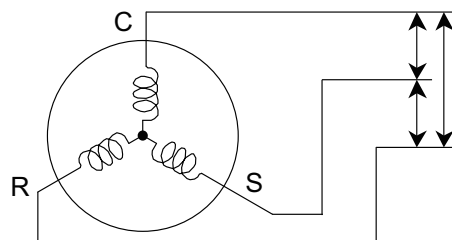

→ If the resistance value is 0Ω or infinite, replace compressor.



Check point 3. Replace inverter PCB

If check point 1 to 2 do not improve the symptom, replace main PCB.

4-3. Outdoor unit Electronic Expansion Valve (EEV)

Check point 1. Check connections

Check connection of connector. (Loose connector or open cable)

NOTE: For details of wiring diagram, refer to "Wiring diagrams" in Chapter 2. TECHNICAL DATA AND PARTS LIST on page 02-13.

Check point 2. Check coil of EEV

Remove connector, check each winding resistance of coil.

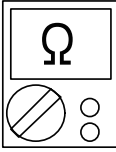
Read wire	Resistance value
White - Red	$46 \Omega \pm 4 \Omega$ at 68 °F (20 °C) 
Yellow - Red	
Orange - Red	
Blue - Red	

→ If Resistance value is abnormal, replace EEV.

Check point 3. Check voltage from main PCB

Remove connector and check voltage (DC 12 V)

→ If it does not appear, replace main PCB.



Check point 4. Check noise at start up

Turn on the power and check the operation noise.

→ If an abnormal noise does not show, replace main PCB.

Check point 5. Check opening and closing operation of valve

When valve is closed, it has a temp. difference between inlet and outlet

CLOSE
 Example : Hot Gas

Pipe (In)
 Hi TEMP.

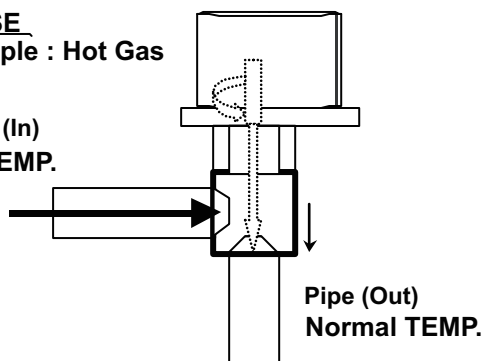

If it is open, it has no temp. difference between inlet and outlet

OPEN
 Example : Hot Gas

Pipe (In)
 Hi TEMP.

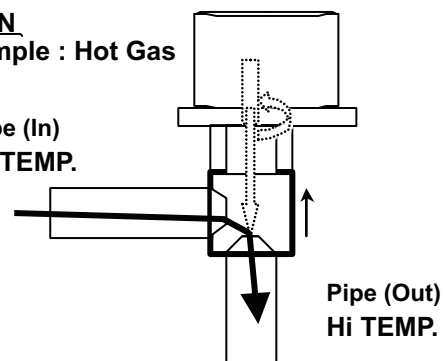

Check point 6. Check strainer

- Strainer normally does not have temperature difference between inlet and outlet as shown below.

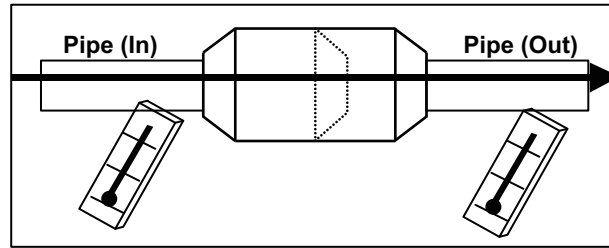

- If there is a difference like shown below, there is a possibility of inside clogged. In this case, replace the strainer.

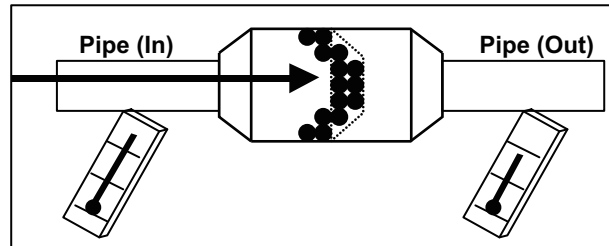

4-4. Indoor unit fan motor

Check point 1. Check rotation of fan

Rotate the fan by hand when operation is off.
 (Check if fan is caught, dropped off or locked motor)
 → If fan or bearing is abnormal, replace it.

Check point 2. Check resistance of indoor fan motor

Refer to below. Circuit-test "Vm" and "GND" terminal

NOTE: Vm: DC voltage, GND: Earth terminal

→ If they are short-circuited (below 300 kΩ), replace indoor fan motor and controller PCB.

Pin number (wire color)	Terminal function (symbol)
1 (Red)	DC voltage (Vm)
2	No function
3	No function
4 (Black)	Ground terminal (GND)
5 (White)	Control voltage (Vcc)
6 (Yellow)	Speed command (Vsp)
7 (Brown)	Revolution pulse (PG)

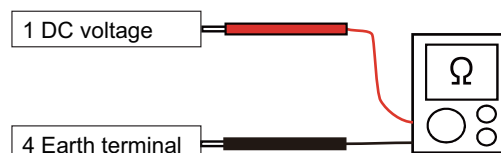

4-5. Outdoor unit fan motor

Check point 1. Check rotation of fan

Rotate the fan by hand when operation is off.
 (Check if fan is caught, dropped off or locked motor)
 → If fan or bearing is abnormal, replace it.

Check point 2. Check resistance of outdoor fan motor

Refer to below. Circuit-test "Vm" and "GND" terminal

NOTE: Vm: DC voltage, GND: Earth terminal

→ If they are short-circuited (below 300 kΩ), replace outdoor fan motor and main PCB.

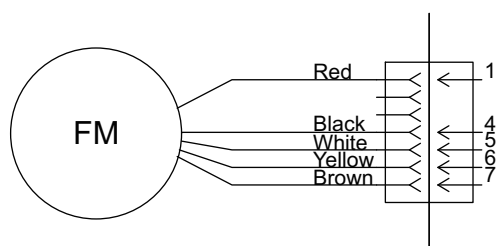

Pin number (wire color)	Terminal function (symbol)
1 (Red)	DC voltage (Vm)
2	No function
3	No function
4 (Black)	Earth terminal (GND)
5 (White)	Control voltage (Vcc)
6 (Yellow)	Speed command (Vsp)
7 (Brown)	Feed back (FG)

5. Thermistor resistance values

5-1. Indoor unit

■ Room temperature thermistor

Temperature °F (°C)	Resistance (kΩ)	Voltage (V)
14.0 (-10.0)	58.25	0.73
23.0 (-5.0)	44.03	0.93
32.0 (0.0)	33.62	1.15
41.0 (5.0)	25.92	1.39
50.0 (10.0)	20.17	1.66
59.0 (15.0)	15.84	1.94
68.0 (20.0)	12.54	2.22
77.0 (25.0)	10.00	2.50
86.0 (30.0)	8.04	2.77
95.0 (35.0)	6.51	3.03
104.0 (40.0)	5.30	3.27
113.0 (45.0)	4.35	3.48

■ Heat exchanger temperature thermistor

Temperature °F (°C)	Resistance (kΩ)	Voltage (V)
-22.0 (-30.0)	1,131.91	0.21
-13.0 (-25.0)	804.52	0.29
-4.0 (-20.0)	579.59	0.40
5.0 (-15.0)	422.89	0.53
14.0 (-10.0)	312.27	0.69
23.0 (-5.0)	233.21	0.88
32.0 (0.0)	176.03	1.10
41.0 (5.0)	134.23	1.36
50.0 (10.0)	103.34	1.63
59.0 (15.0)	80.28	1.92
68.0 (20.0)	62.91	2.21
77.0 (25.0)	49.70	2.51
86.0 (30.0)	39.57	2.79
95.0 (35.0)	31.74	3.06
104.0 (40.0)	25.64	3.30
113.0 (45.0)	20.85	3.53
122.0 (50.0)	17.06	3.73
131.0 (55.0)	14.05	3.90
140.0 (60.0)	11.64	4.05
149.0 (65.0)	9.69	4.19

5-2. Outdoor unit

■ Discharge temperature thermistor

Temperature °F (°C)	Resistance (kΩ)	Voltage (V)
-22.0 (-30.0)	1,013.11	0.06
-12.0 (-25.0)	729.09	0.09
-4.0 (-20.0)	531.56	0.12
5.0 (-15.0)	392.31	0.16
14.0 (-10.0)	292.91	0.21
23.0 (-5.0)	221.09	0.28
32.0 (0.0)	168.60	0.36
41.0 (5.0)	129.84	0.46
50.0 (10.0)	100.91	0.57
59.0 (15.0)	79.12	0.71
68.0 (20.0)	62.55	0.86
77.0 (25.0)	49.84	1.03
86.0 (30.0)	40.01	1.23
95.0 (35.0)	32.35	1.43
104.0 (40.0)	26.34	1.65
113.0 (45.0)	21.58	1.88
122.0 (50.0)	17.79	2.11
131.0 (55.0)	14.75	2.34
140.0 (60.0)	12.30	2.57
149.0 (65.0)	10.32	2.79
158.0 (70.0)	8.69	3.00
167.0 (75.0)	7.36	3.19
176.0 (80.0)	6.27	3.37
185.0 (85.0)	5.36	3.54
194.0 (90.0)	4.60	3.69
203.0 (95.0)	3.96	3.83
212.0 (100.0)	3.43	3.96
221.0 (105.0)	2.98	4.07
230.0 (110.0)	2.60	4.17
239.0 (115.0)	2.27	4.26
248.0 (120.0)	2.00	4.33

■ Compressor temperature thermistor

Temperature °F (°C)	Resistance (kΩ)	Voltage (V)
-22.0 (-30.0)	1,013.11	0.06
-12.0 (-25.0)	729.09	0.09
-4.0 (-20.0)	531.56	0.12
5.0 (-15.0)	392.31	0.16
14.0 (-10.0)	292.91	0.21
23.0 (-5.0)	221.09	0.28
32.0 (0.0)	168.60	0.36
41.0 (5.0)	129.84	0.46
50.0 (10.0)	100.91	0.57
59.0 (15.0)	79.12	0.71
68.0 (20.0)	62.55	0.86
77.0 (25.0)	49.84	1.03
86.0 (30.0)	40.01	1.23
95.0 (35.0)	32.35	1.43
104.0 (40.0)	26.34	1.65
113.0 (45.0)	21.58	1.88
122.0 (50.0)	17.79	2.11
131.0 (55.0)	14.75	2.34
140.0 (60.0)	12.30	2.57
149.0 (65.0)	10.32	2.79
158.0 (70.0)	8.70	3.00
167.0 (75.0)	7.36	3.19
176.0 (80.0)	6.27	3.37
185.0 (85.0)	5.36	3.54
194.0 (90.0)	4.60	3.69
203.0 (95.0)	3.96	3.83
212.0 (100.0)	3.43	3.96
221.0 (105.0)	2.98	4.07
230.0 (110.0)	2.60	4.17
239.0 (115.0)	2.27	4.26
248.0 (120.0)	2.00	4.33

■ Heat exchanger temperature thermistor

Temperature °F (°C)	Resistance (kΩ)	Voltage (V)
-22.0 (-30.0)	95.58	0.24
-12.0 (-25.0)	68.90	0.32
-4.0 (-20.0)	50.31	0.43
5.0 (-15.0)	37.19	0.57
14.0 (-10.0)	27.81	0.73
23.0 (-5.0)	21.02	0.92
32.0 (0.0)	16.05	1.14
41.0 (5.0)	12.38	1.39
50.0 (10.0)	9.63	1.65
59.0 (15.0)	7.56	1.93
68.0 (20.0)	5.98	2.21
77.0 (25.0)	4.77	2.49
86.0 (30.0)	3.84	2.77
95.0 (35.0)	3.11	3.02
104.0 (40.0)	2.53	3.26
113.0 (45.0)	2.08	3.48
122.0 (50.0)	1.71	3.68
131.0 (55.0)	1.42	3.85
140.0 (60.0)	1.19	4.00
149.0 (65.0)	1.00	4.13
158.0 (70.0)	0.84	4.25
167.0 (75.0)	0.71	4.35
176.0 (80.0)	0.61	4.43

■ Outdoor temperature thermistor

Temperature °F (°C)	Resistance (kΩ)	Voltage (V)
-22.0 (-30.0)	224.33	0.73
-12.0 (-25.0)	159.71	0.97
-4.0 (-20.0)	115.24	1.25
5.0 (-15.0)	84.21	1.56
14.0 (-10.0)	62.28	1.90
23.0 (-5.0)	46.58	2.26
32.0 (0.0)	35.21	2.61
41.0 (5.0)	26.88	2.94
50.0 (10.0)	20.72	3.25
59.0 (15.0)	16.12	3.52
68.0 (20.0)	12.64	3.76
77.0 (25.0)	10.00	3.97
86.0 (30.0)	7.97	4.14
95.0 (35.0)	6.40	4.28
104.0 (40.0)	5.18	4.41
113.0 (45.0)	4.21	4.51
122.0 (50.0)	3.45	4.59
131.0 (55.0)	2.85	4.65

4. CONTROL AND FUNCTIONS

CONTENTS

4. CONTROL AND FUNCTIONS

1. Rotation number control of compressor.....	04-1
1-1. Cooling operation	04-1
1-2. Heating operation	04-2
1-3. Dry operation	04-2
1-4. Rotation number of compressor at normal start-up	04-3
1-5. Limitation of compressor rotation number by outdoor temperature.....	04-4
2. Auto changeover operation.....	04-5
3. Fan control.....	04-7
3-1. Indoor fan control.....	04-7
3-2. Outdoor fan control	04-10
4. Timer operation control	04-11
4-1. Wireless remote control	04-11
4-2. Wired remote control	04-13
5. Defrost operation control	04-16
5-1. Defrost operation in heating operation stopped	04-17
6. Various control	04-18
6-1. Auto restart	04-18
6-2. MIN. HEAT operation	04-18
6-3. ECONOMY operation	04-18
6-4. Fresh air control.....	04-18
6-5. Compressor preheating	04-19
6-6. External electrical heater control	04-19
6-7. Electronic expansion valve control	04-19
6-8. Drain pump control	04-20
6-9. Prevention to restart for 3 minutes (3 minutes st)	04-22
6-10. 4-way valve control	04-22
6-11. Unit status monitoring and the detected value indication	04-23
7. Various protections.....	04-25
7-1. Discharge gas temperature over-rise prevention control	04-25
7-2. Anti-freezing control (cooling and dry mode)	04-25
7-3. Current release control	04-26
7-4. Indoor unit fan motor over temperature protection.....	04-26
7-5. Compressor temperature protection	04-27
7-6. Low outdoor temperature protection.....	04-27
7-7. High temperature and high pressure release control	04-28

1. Rotation number control of compressor

1-1. Cooling operation

A sensor (room temperature thermistor) built in the indoor unit body will usually perceive difference or variation between a set temperature and present room temperature, and controls the operation rotation number of the compressor.

- If the room temperature is 11 °F (6.0 °C) higher than a set temperature, the operation rotation number of compressor will attain to maximum performance.
- If the room temperature is 2 °F (1.0 °C) lower than a set temperature, the compressor will be stopped.
- When the room temperature is within the range of +11 °F (6.0 °C) to -2 °F (1.0 °C) of the setting temperature, the rotation number of compressor is controlled within the range shown in the table below. However, the maximum rotation number is limited in the range shown in the figure below based on the indoor fan mode and the outdoor temperature.

• Rotation number range of compressor

Unit: rps

Model name	Minimum rotation number	Maximum rotation number
ARUH12LUAS	8	58

• Limit of maximum speed based on outdoor temperature

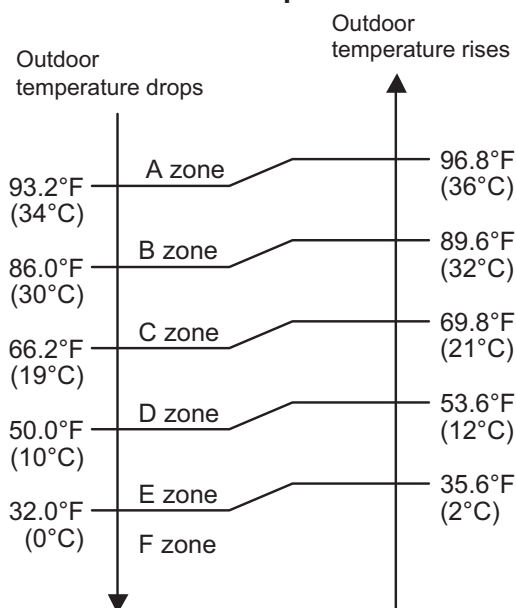

Unit: rps

Model name	Outdoor temperature zone	Indoor unit fan mode			
		HIGH	MED	LOW	QUIET
ARUH12LUAS	A zone	58	34	30	26
	B zone	58	34	30	26
	C zone	58	34	30	26
	D zone	34	28	24	18
	E zone	34	28	24	18
	F zone	34	28	24	18

1-2. Heating operation

A sensor (room temperature thermistor) built in indoor unit body will usually perceive difference or variation between setting temperature and present room temperature, and controls operation rotation number of compressor.

- If the room temperature is 11 °F (6.0 °C) lower than a set temperature, the operation rotation number of compressor will attain to maximum performance.
- If the room temperature is 2 °F (1.0 °C) higher than a set temperature, the compressor will be stopped.
- When the room temperature is within the range of +2 °F (1.0°C) to -11 °F (6.0°C) of the setting temperature, the rotation number of compressor is controlled within the range shown below.

- **Rotation number range of compressor**

Unit: rps

Model name	Minimum rotation number	Maximum rotation number
ARUH12LUAS	8	130

1-3. Dry operation

The rotation number of compressor shall change according to the temperature, set temperature, and room temperature variation which the room temperature sensor of the indoor unit has detected as shown in the table below.

Zone is defined by set temperature and room temperature.

- **Rotation number range of compressor**

Unit: rps

Model name	Outdoor temperature zone	Operating rotation number
ARUH12LUAS	X zone	26
	J zone	26
	Y zone	0

- **Compressor control based on room temperature**

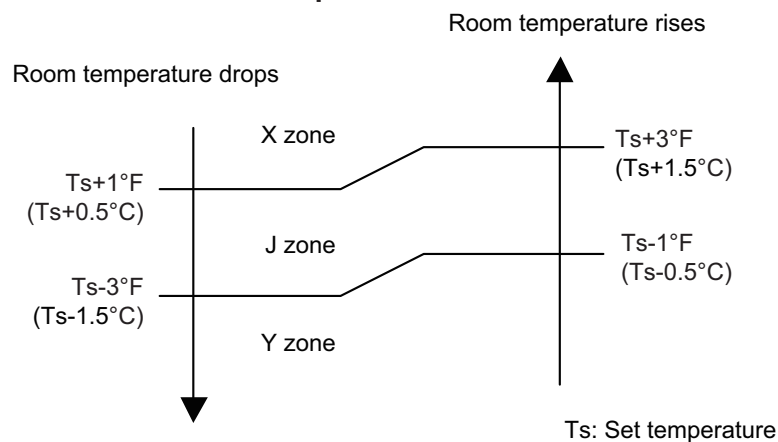

1-4. Rotation number of compressor at normal start-up

■ Model: AOUH12LUAS1

Rotation number of compressor soon after starting is controlled as below.

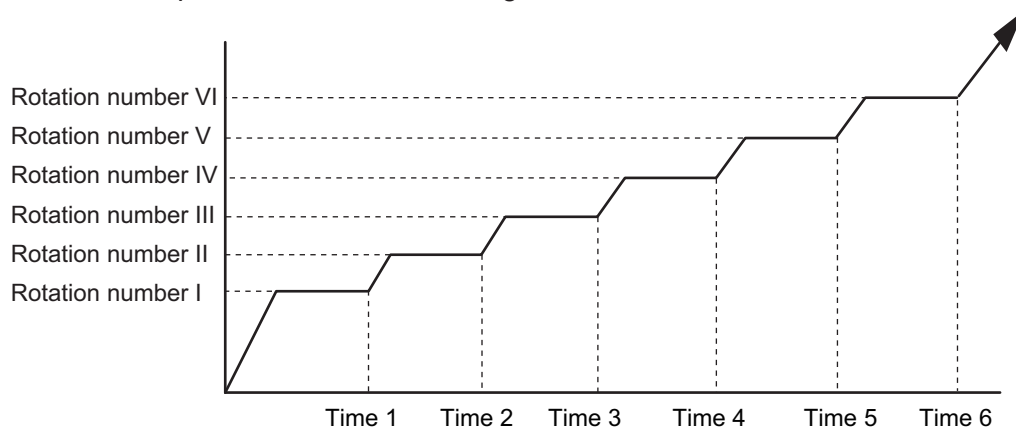

Rotation number (rps)	I 35	II 52	III 64	IV 71	V 89	VI 97
Time (sec)	1 60	2 140	3 170	4 200	5 350	6 410

CONTROL AND FUNCTIONS

CONTROL AND FUNCTIONS

1-5. Limitation of compressor rotation number by outdoor temperature

The minimum rotation number of compressor is limited by outdoor temperature as below.

- **Cooling/Dry mode**

100.4°F (38°C)	F zone
66.2°F (19°C)	E zone
50.0°F (10°C)	D zone
32.0°F (0°C)	C zone
14.0°F (-10°C)	B zone
	A zone

Model name	Outdoor temperature zone	Limitation of compressor rotation number
AOUH12LUAS1	A zone	37 rps
	B zone	37 rps
	C zone	37 rps
	D zone	28 rps
	E zone	1 rps
	F zone	22 rps

- **Heating mode**

66.2°F (19°C)	F zone
41.0°F (5°C)	E zone
32.0°F (0°C)	D zone
5.0°F (-15°C)	C zone
-13.0°F (-25°C)	B zone
	A zone

Model name	Outdoor temperature zone	Limitation of compressor rotation number
AOUH12LUAS1	A zone	34 rps
	B zone	34 rps
	C zone	34 rps
	D zone	15 rps
	E zone	14 rps
	F zone	14 rps

2. Auto changeover operation

When the air conditioner is set to AUTO mode by remote controller, operation starts in the optimum mode from among heating, cooling, dry and monitoring modes. During operation, the optimum mode is automatically switched in accordance with temperature changes. The temperature can be set between 64.4°F (18°C) and 86.0°F (30°C) in 1.8°F (1.0°C) steps.

- When operation starts, indoor fan and outdoor fan are operated for around 1 minute. Room temperature and outdoor temperature are sensed, and the operation mode is selected in accordance with the table below.

Room temperature	Operation mode
$Tr > Ts + 3.6^{\circ}\text{F}$ (2°C)	Cooling
$Ts + 3.6^{\circ}\text{F}$ (2°C) $\geq Tr \geq Ts - 3.6^{\circ}\text{F}$ (2°C)	Middle zone
$Tr < Ts - 3.6^{\circ}\text{F}$ (2°C)	Heating

Tr: Room temperature

Ts: Setting temperature

NOTE: When the operation mode is middle zone, indoor unit operation mode is selected as below.

- Same operation mode is selected as outdoor unit.
If outdoor unit is operating in cooling and heating mode, indoor unit will be operated by the same operation mode.
- Selected by outdoor temperature.
If outdoor unit is operating in other than cooling and heating mode, indoor unit will be operated according to the outdoor temperature as below.

Outdoor temp.	Operation mode
77.0°F (25°C) or more	Cooling
Less than 77.0°F (25°C)	Heating

- When the compressor was stopped for 6 consecutive minutes by temperature control function after the cooling or heating mode was selected as above, operation is switched to monitoring mode and the operation mode selection is done again.
- When the middle zone is selected on the predetermining of the operation mode, the operation mode before the changing to the monitoring mode is selected.

Operation flow chart

Ts: Setting temperature

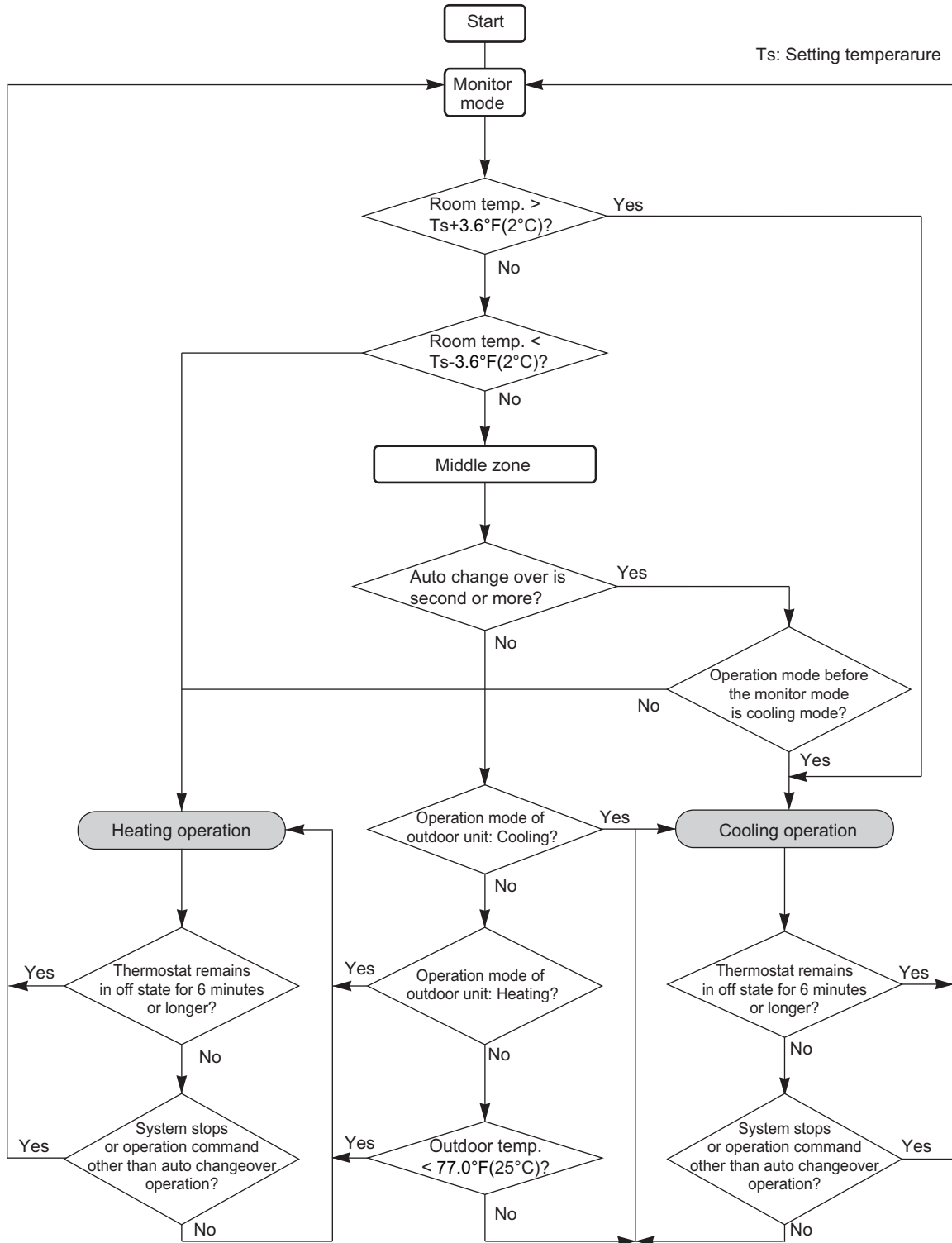

CONTROL AND FUNCTIONS

CONTROL AND FUNCTIONS

3. Fan control

Tr: Room temperature

Ts: Setting temperature

3-1. Indoor fan control

■ Fan speed

Indoor fan speed is defined as below.

Operation mode	Fan mode	Speed (rpm)
		ARUH12LUAS
Heating	HIGH	920
	MED+	760
	MED	760
	LOW	670
	QUIET	590
	S-LOW	370
Cooling/Fan	HIGH	920
	MED	760
	LOW	670
	QUIET	590
	Soft quiet	480* ¹
	S-LOW	370* ²
Dry		X zone: 590 J zone: 590

*1: Fan mode only

*2: Cooling mode only

■ Fan operation

Airflow can be switched in 5 steps such as AUTO, QUIET, LOW, MED, HIGH while indoor unit fan only runs.

When fan mode is set at AUTO, it operates on MED fan speed.

■ Cooling operation

Switch the airflow AUTO, and indoor fan motor will run according to room temperature, as below.

On the other hand, if switched in HIGH—QUIET, indoor motor will run at a constant airflow of COOL operation modes QUIET, LOW, MED, HIGH as shown in “Fan speed” above.

Airflow change over (Cooling: Auto)

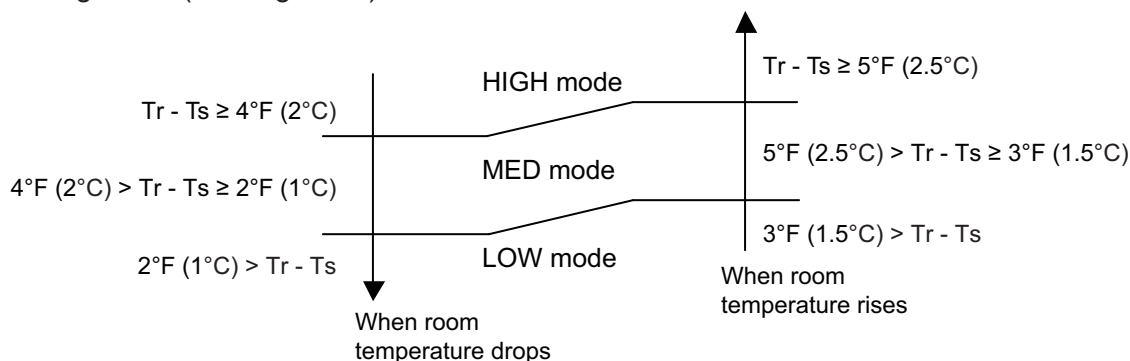

■ Dry operation

During dry operation, fan speed setting can not be changed as shown in “Fan speed” above.

■ Heating operation

Switch the airflow AUTO, and the indoor fan motor will run according to a room temperature, as below.

On the other hand, if switched in HIGH—QUIET, the indoor motor will run at a constant airflow of HEAT operation modes QUIET, LOW, MED, HIGH as shown in “Fan speed” above.

Airflow change over (Heating: Auto)

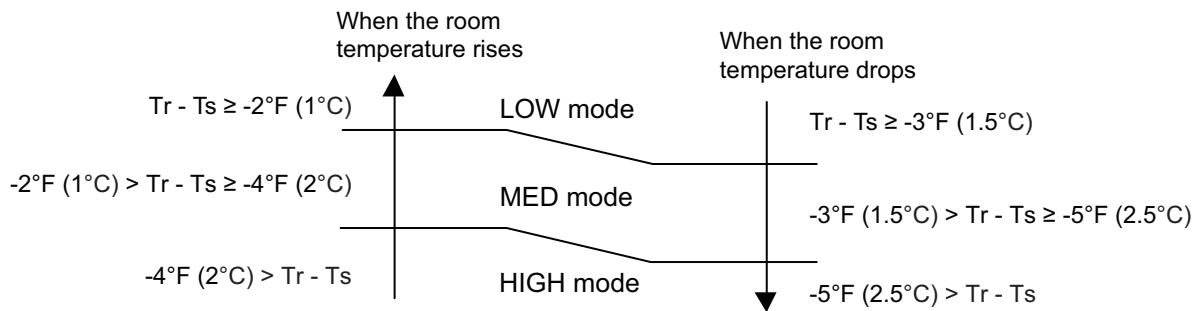

■ Cool air prevention control (heating mode)

The maximum value of the indoor fan speed is set as shown below, based on the detected temperature by the indoor heat exchanger sensor on heating mode.

• Normal operation

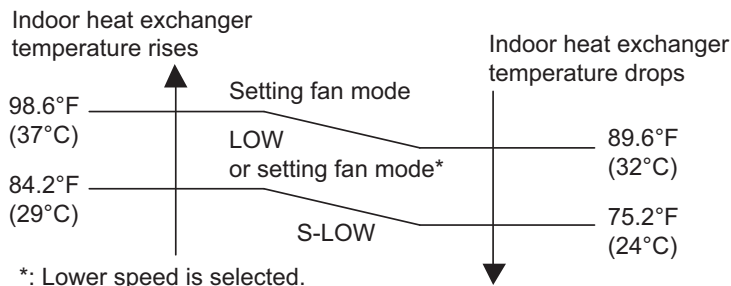

13 minutes later:

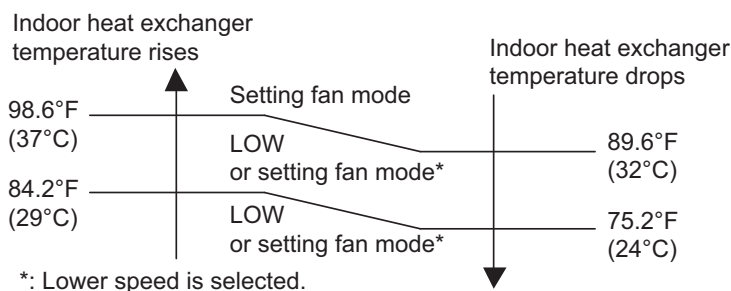

• MIN. HEAT operation

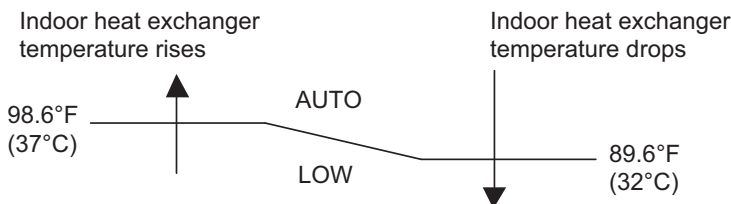

Moisture return prevention control (cooling and dry mode)

Switch the airflow AUTO at cooling mode, and the indoor fan motor will run as shown below.

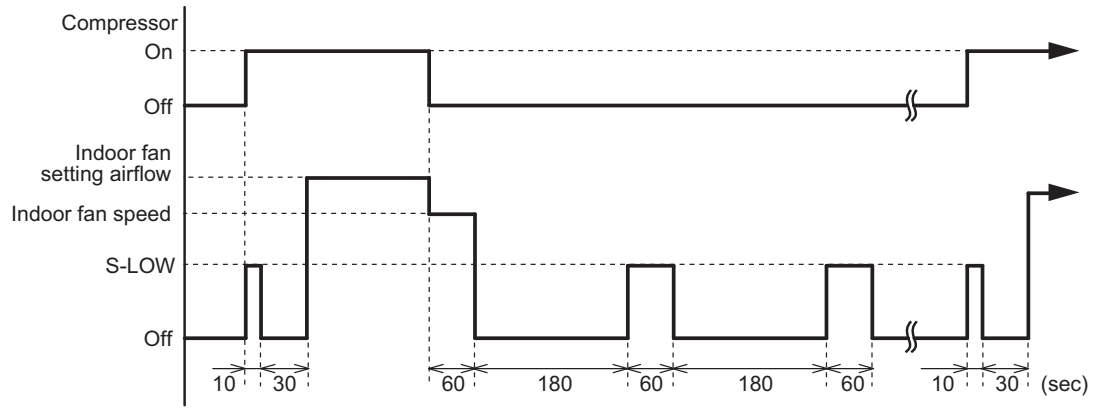

CONTROL AND FUNCTIONS

CONTROL AND FUNCTIONS

3-2. Outdoor fan control

Outdoor fan motor

This outdoor unit has a DC fan motor. (Control method is different between AC and DC motors.)

Fan speed

Model: AOUH12LUAS1

Fan speed is defined by outdoor temperature and compressor frequency.

Outside air temperature zone selection

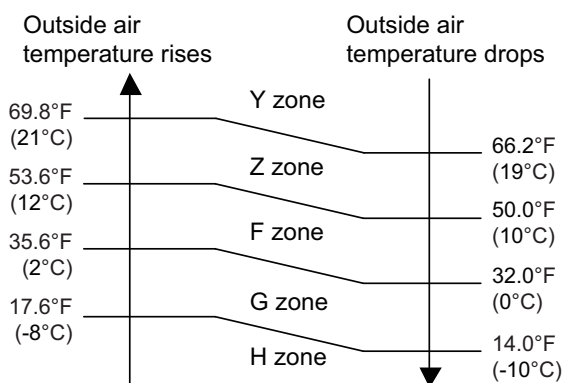

Unit: rpm

Fan step	Cooling	Heating	Dry	Cooling or dry at low outdoor temp.				
	Y zone		Y zone	Z zone	F zone	G zone	H zone	
S-HIGH2	—	1,100	—	—	—	—	—	—
S-HIGH1	1,050	1,100	—	—	—	—	—	—
HIGH	1,050	1,100	—	—	—	—	—	—
10	—	1,100	—	—	—	—	—	—
9	1,050	1,100	1,050	850	320	270	270	270
8	810	870	810	850	320	270	270	270
7	810	760	810	770	320	270	270	270
6	560	760	560	630	270	230	230	230
5	560	680	560	440	270	230	230	230
4	440	530	440	320	270	230	230	230
3	440	500	440	320	270	230	230	230
2	440	420	440	320	270	230	230	230
1	440	420	440	320	270	230	230	230

NOTE: After defrost control on the heating mode, the fan speed is kept higher regardless of the compressor frequency.

Fan speed after defrost control: 1,100 rpm

4. Timer operation control

4-1. Wireless remote control

On/Off timer	Program timer	Sleep timer	Weekly timer
○	○	○	—

■ On/Off timer

- Off timer: When the clock reaches the set timer, the air conditioner will be turned off.

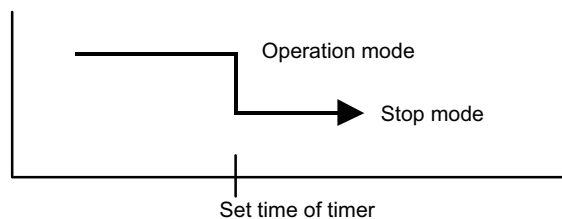

- On timer: When the clock reaches the set timer, the air conditioner will be turned on.

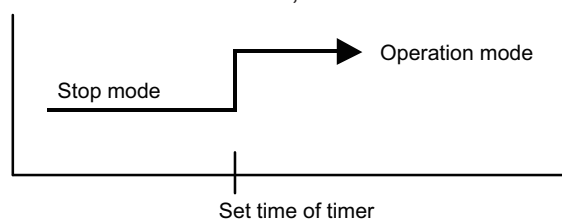

■ Program timer

- The program timer allows the off timer and the on timer to be used in combination one time.

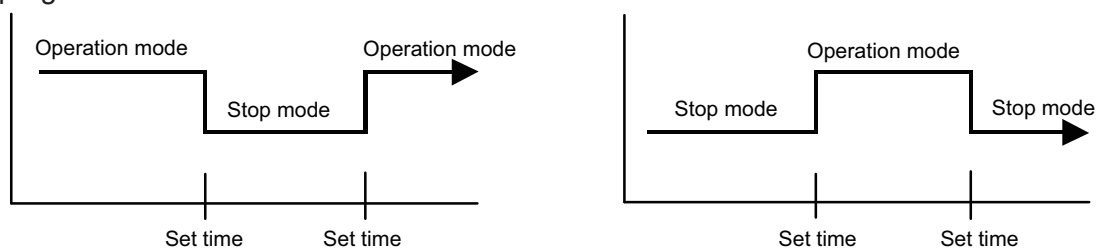

- Operation will start from the timer setting (either off timer and on timer) whichever is closest to the clock current timer setting. The order of operations is indicated by the allow in the remote controller screen.
- Sleep timer operation cannot be combined with on timer operation.

■ Sleep timer

If the sleep timer is set, the room temperature is monitored and the operation is stopped automatically. If the operation mode or the set temperature is change after the sleep timer is set, the operation is continued according to the changed setting of the sleep timer from that time on.

- In the cooling operation mode

When the sleep timer is set, the setting temperature is increased 1.8°F (1°C). It increases the setting temperature another 1.8°F (1°C) after 1 hour. After that, the setting temperature is not changed and the operation is stopped at the setting time.

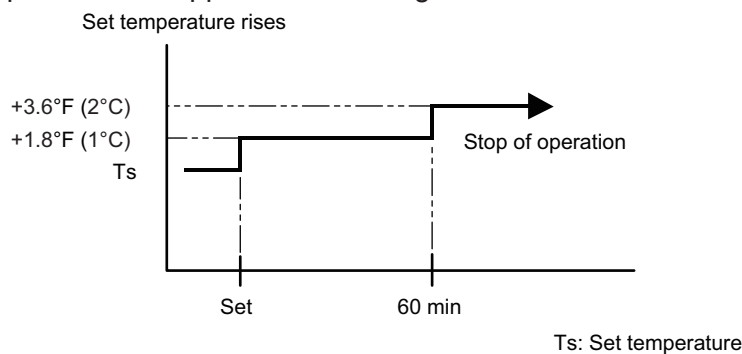

- In the heating operation mode

When the sleep timer is set, the setting temperature is decreased 1.8°F (1°C). It decreases the setting temperature another 1.8°F (1°C) every 30 minutes. Upon lowering 7.2°F (4°C), the setting temperature is not changed and the operation is stopped at the setting time.

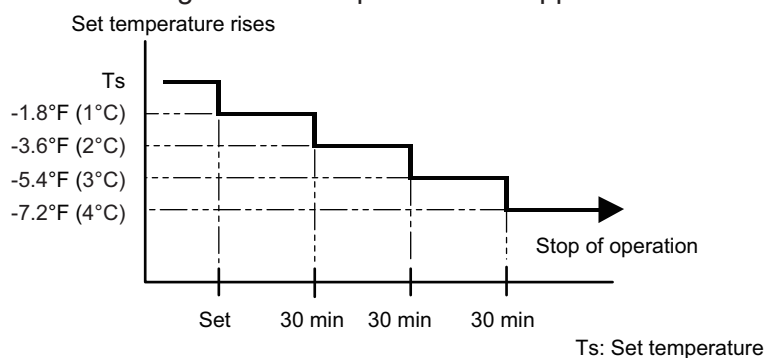

4-2. Wired remote control

On/Off timer	Program timer	Sleep timer	Weekly timer	Temperature Setback Timer
○	○	○	○	○

■ On/Off timer

- Off timer: When the clock reaches the set timer, the air conditioner will be turned off.

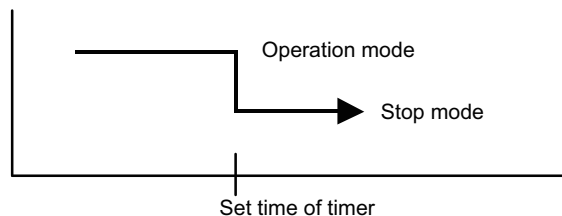

- On timer: When the clock reaches the set timer, the air conditioner will be turned on.

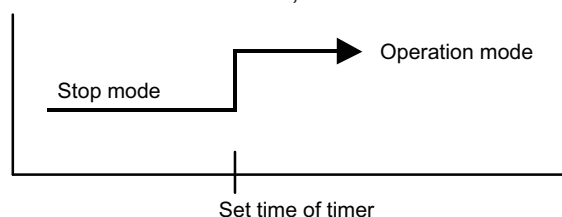

■ Program timer

- The program timer allows the off timer and the on timer to be used in combination one time.

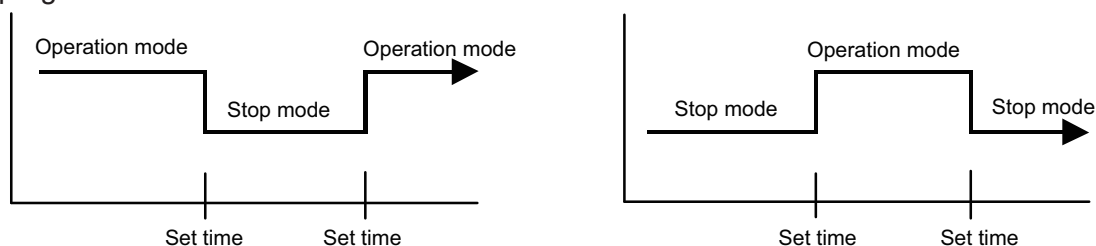

- Operation will start from the timer setting (either off timer and on timer) whichever is closest to the clock current timer setting. The order of operations is indicated by the allow in the remote controller screen.
- Sleep timer operation cannot be combined with on timer operation.

■ Sleep timer

If the sleep timer is set, the room temperature is monitored and the operation is stopped automatically. If the operation mode or the set temperature is change after the sleep timer is set, the operation is continued according to the changed setting of the sleep timer from that time on.

- In the cooling operation mode

When the sleep timer is set, the setting temperature is increased 1.8°F (1°C). It increases the setting temperature another 1.8°F (1°C) after 1 hour. After that, the setting temperature is not changed and the operation is stopped at the setting time.

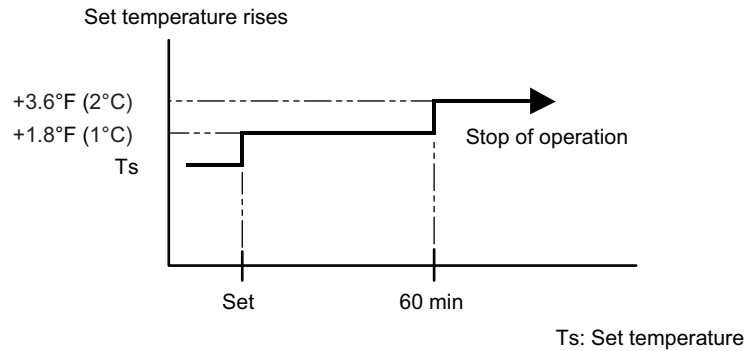

- In the heating operation mode

When the sleep timer is set, the setting temperature is decreased 1.8°F (1°C). It decreases the setting temperature another 1.8°F (1°C) every 30 minutes. Upon lowering 7.2°F (4°C), the setting temperature is not changed and the operation is stopped at the setting time.

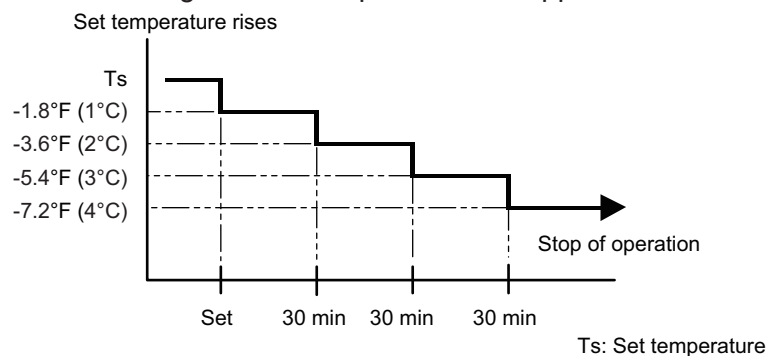

■ Weekly timer

On and off timer can be combined, and up to 4 reservations per day and 28 reservations per week. Before setting the program, set the week and time of the air conditioner at first. If the week and time are not set, the weekly timer will not operate correctly at the setting time.

■ Temperature Setback Timer

- The temperature setback timer only changes the set temperature for 7 days, it cannot be used to start or stop air conditioner operation.
- The temperature setback timer can be set to operate up to two times per day but only one temperature setting can be used.
- During COOLING/DRY mode, the air conditioner will operate at a minimum of 64°F (18°C) even if the SET BACK temperature is set to 63°F (17°C) or lower.

Case of Temperature Setback Timer on the Cooling operation. (Setting temperature :72°F [22°C], SET BACK temperature :78°F [26°C])

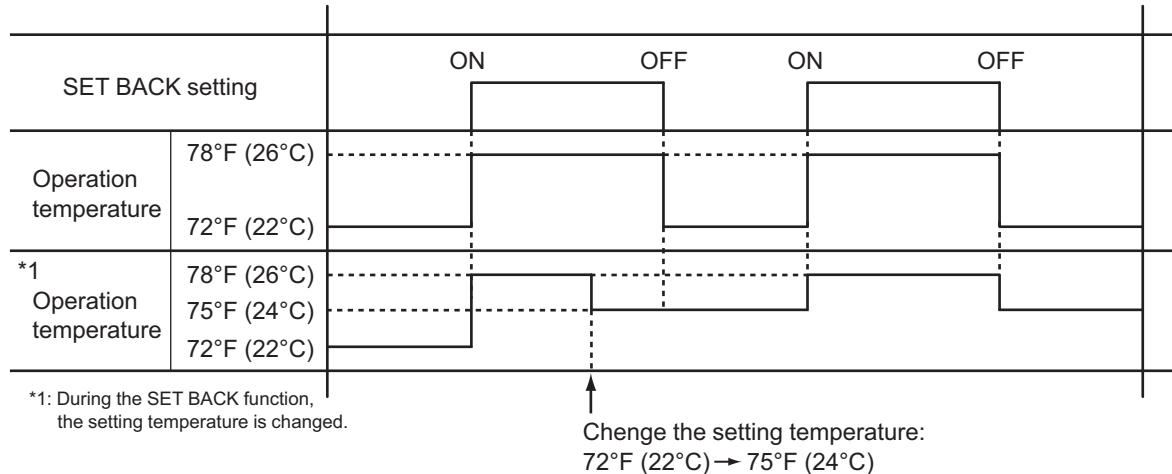

5. Defrost operation control

Tn: Outdoor unit heat exchanger temperature

Ta: Outdoor temperature

Tn10: Temperature at 10 minutes after compressor start

Tnb: Temperature before 5 minutes

• Triggering condition

The defrost operation starts when outdoor unit heat exchanger temperature sensor detects the temperature lower than the values shown below.

– 1st time defrosting after starting operation

Compressor integrating operation time	Less than 17 min.	17 to 57 min.	More than 57 min.
Condition	Does not operate	$T_n \leq 15.8^\circ\text{F} (-9^\circ\text{C})$ and $T_n - T_a \geq 9.0^\circ\text{F} (5^\circ\text{C})$	$T_n \leq 23.0^\circ\text{F} (-5^\circ\text{C})$

– 2nd time and after

Compressor integrating operation time	Less than 40 min.	More than 40 min.
Condition	Does not operate	$T_n - T_{n10} < -9.0^\circ\text{F} (-5^\circ\text{C})$ ($T_n \leq 21.2^\circ\text{F} [-6^\circ\text{C}]$) $T_n - T_{nb} < -3.6^\circ\text{F} (-2^\circ\text{C})$ ($T_n \leq 21.2^\circ\text{F} [-6^\circ\text{C}]$) $T_n \leq -4.0^\circ\text{F} (-20^\circ\text{C})$ ($T_a \geq 14.0^\circ\text{F} [-10^\circ\text{C}]$) $T_n \leq 19.4^\circ\text{F} (-7^\circ\text{C})$ or $T_n \leq -13.0^\circ\text{F} (-25^\circ\text{C})$ ($T_a < 14.0^\circ\text{F} [-10^\circ\text{C}]$)

– Integrating defrost (Constant monitoring)

Compressor integrating operation time	More than 240 min. (For long continuous operation)	More than 215 min. (For long continuous operation)	Less than 10 min.* (For intermittent operation)
Condition	$T_n \leq 26.6^\circ\text{F} (-3^\circ\text{C})$	$T_n \leq 23.0^\circ\text{F} (-5^\circ\text{C})$	Count of the compressor off: 40 times

*: If the compressor continuous operation time is less than 10 minutes, the number of the compressor off is counted. If any defrost operated, the compressor off count is cleared.

• Release condition

Depending on the triggering condition, different release conditions apply.

– Normal defrost operation

The defrost operation is released when either one of the conditions below is satisfied.

Outdoor unit heat exchanger temperature (after 1 minute or later since compressor start)	55.4°F (13°C) or more ($T_a \leq 33.8^\circ\text{F} [1^\circ\text{C}]$) 50.0°F (10°C) or more ($T_a > 33.8^\circ\text{F} [1^\circ\text{C}]$)
Compressor operation time	15 minutes

– Integrating defrost (constant monitoring)

The defrost operation is released when either one of the conditions below is satisfied.

Outdoor unit heat exchanger temperature (after 1 minute or later since compressor start)	55.4°F (13°C) or more
Compressor operation time	15 minutes

5-1. Defrost operation in heating operation stopped

If the outdoor unit is frosted when stopping the heating operation, it stops after performing the automatic defrosting operation.

In this time, if the indoor unit operation lamp flashes slowly (6 sec on/2 sec off), the outdoor unit allow the heat exchanger to defrost, and then stop.

• Triggering condition

When all of the following conditions are satisfied in heating operation

- Compressor operation integrating time: 30 minutes or more
- Compressor continuous operation time: 10 minutes or more
- Outdoor unit heat exchanger temperature: 24.8 °F (-4 °C) or less

• Release condition

Depending on the triggering condition, different release conditions apply.

– Normal defrost operation

The defrost operation is released when either one of the conditions below is satisfied.

Outdoor unit heat exchanger temperature (after 1 minute or later since compressor start)	55.4°F (13°C) or more (Ta ≤ 33.8 °F [1 °C]) 50.0°F (10°C) or more (Ta > 33.8 °F [1 °C])
Compressor operation time	15 minutes

– Integrating defrost (constant monitoring)

The defrost operation is released when either one of the conditions below is satisfied.

Outdoor unit heat exchanger temperature (after 1 minute or later since compressor start)	55.4°F (13°C) or more
Compressor operation time	15 minutes

6. Various control

6-1. Auto restart

When the power was interrupted by a power failure etc. during operation, the operation contents at that time are memorized and when the power is recovered, operation is automatically started with the memorized operation contents.

Operation contents memorized when the power is interrupted	
Operation mode	
Setting temperature	
Fan mode setting	
Timer mode and set time (set by wireless remote controller)	
ECONOMY operation	
MIN. HEAT operation	

6-2. MIN. HEAT operation

MIN. HEAT operation performs as below setting when pressing MIN. HEAT button.

Operation mode	Heating
Setting temperature	50°F (10°C)
Fan mode	AUTO
LED display	Economy
Defrost operation	Operate as normal

6-3. ECONOMY operation

The ECONOMY operation starts by pressing ECONOMY button on the remote controller. The ECONOMY operation is almost the same operation as below settings.

Mode	Cooling/Dry	Heating
Target temperature	Setting temperature +2°F (1°C)	Setting temperature -2°F (1°C)

6-4. Fresh air control

The fan motor for Fresh Air is operated in synchronization with the indoor fan operation as below.

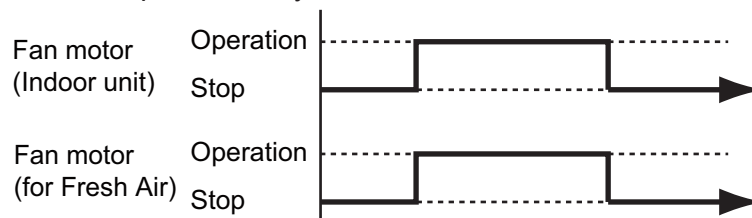

6-5. Compressor preheating

By preheating the compressor, warm airflow is quickly discharged when the operation is started.

• **Triggering condition**

- 30 minutes after compressor stopped.
- Outdoor unit heat exchanger temperature (Tn)

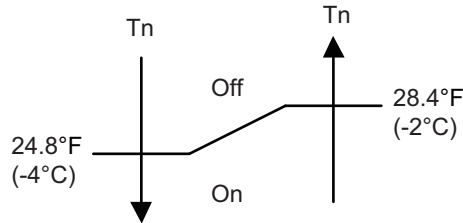

When the jumper wire (JM2) is disconnected:

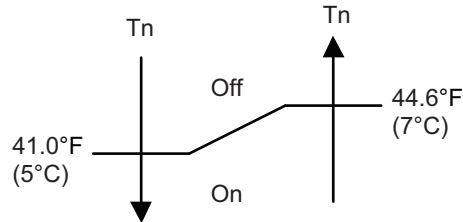

6-6. External electrical heater control

The external electrical heater is operated as below.

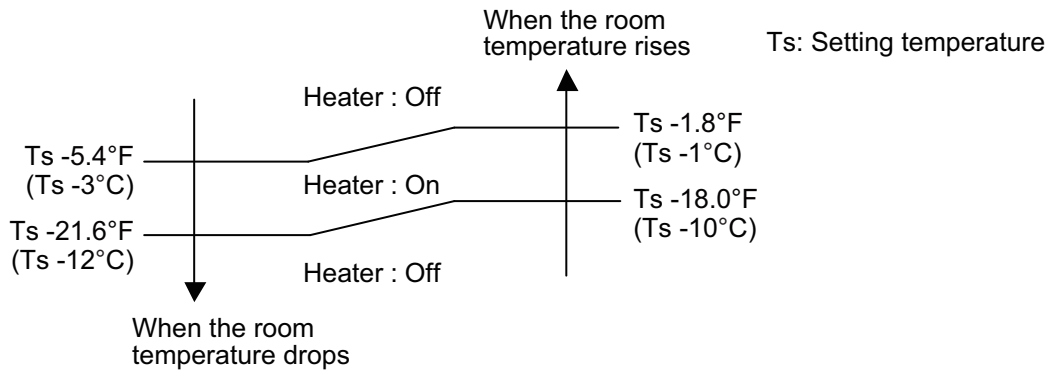

NOTES:

- When the compressor stop, external electric heater is off.
- It operates only in heating mode and when the indoor fan operates. (However, S-LOW is excluded.)

6-7. Electronic expansion valve control

The most proper opening of the electronic expansion valve is calculated and controlled under the present operating condition based on the table below.

Operation mode	Pulse range
Cooling/dry mode	Between 52 and 480 pulses
Heating mode	

NOTE: At the time of supplying the power to the outdoor unit, the initialization of the electronic expansion valve is operated (528 pulses are input to the closing direction).

CONTROL AND FUNCTIONS

CONTROL AND FUNCTIONS

6-8. Drain pump control

■ Drain control for cooling operation

● During the compressor in operation

- **Triggering condition**
The thermostat is turned on during cooling or dry mode.
- **Operation details**
The drain pump is turned on.
- **Release condition**
 - The thermostat is turned off.
Refer to "When the compressor is not in operation" for the operation after release.
 - The compressor is stopped.
Refer to "When the compressor is not in operation" for the operation after release.
 - The operation is switched to heating mode.
Refer to "When the compressor is not in operation" for the operation after release.
 - The float switch is turned on.
Refer to "Overflow control" for the operation after release.
 - The compressor is stopped by Anti-freezing control.
Refer to "The compressor is stopped by Anti-freezing control" for the operation after release.

● When the compressor is not in operation

- **Triggering condition**
 - The thermostat is turned off.
 - The compressor is stopped.
 - The operation is switched to heating mode.
 - The float switch is turned off.
- **Operation details**
 - Count 180 minutes.
 - Start drain pump intermittent operation.

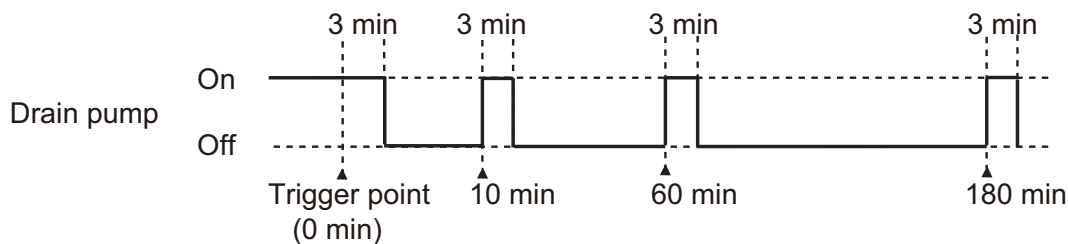

- **Release condition**
 - 3 minutes drain pump operation is finished after 180 minutes count.
 - The operation is switched to cooling or dry mode.
Refer to "During the compressor in operation" for the operation after release.
 - The float switch is turned on.
Refer to "Overflow control" for the operation after release.
- **Operation after release**
The drain pump is turned off and the air conditioner operate according the settings.

● Overflow control

- **Triggering condition**

The float switch is turned on.

- **Operation details**

- The drain pump is turned on.
- When the operation mode is cooling or dry, operate the followings.
 - The compressor is stopped.
 - Then indoor fan control is turned off.

- **Release condition**

- The float switch is turned off.
 - In the case that on the cooling or dry mode the thermostat is on, refer to "[During the compressor in operation](#)" for the operation after release.
 - In other case, refer to "[When the compressor is not in operation](#)" for the operation after release.
- 3 minutes passed

- **Operation after release**

The compressor stopps permanently.

● The compressor is stopped by Anti-freezing control

- **Triggering condition**

During the compressor in operation, the compressor is stopped by Anti-freezing control.

- **Operation details**

The drain pump is kept on in 60 minutes after Anti-freezing control released.

- **Release condition**

60 minutes passed

- **Operation after release**

According to the settings, operate the followings.

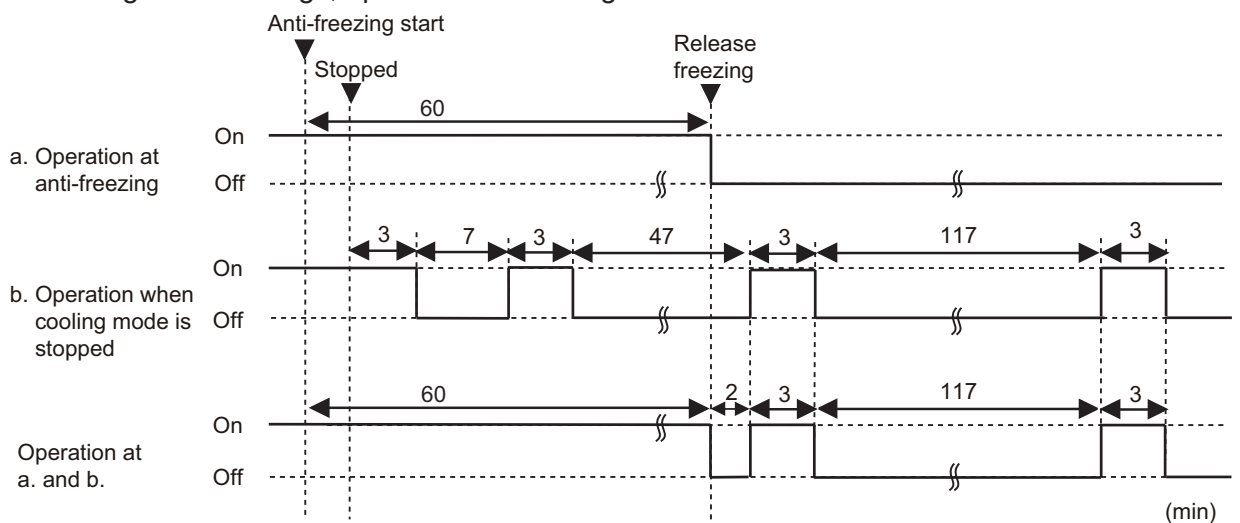

6-9. Prevention to restart for 3 minutes (3 minutes st)

When the compressor fails to start for the number of times below, it does not enter operation status for 3 minutes.

Retry number	50
Retry set number	3

When the compressor fails to start in the retry set number above, the compressor is stopped.

6-10. 4-way valve control

- If heating mode is selected at the compressor start, 4-way valve is energized for heating.
- When the air conditioner is switched between cooling and heating mode, compressor is stopped, and the 4-way valve is switched when the 140 seconds passes and the compressor is started.

6-11. Unit status monitoring and the detected value indication

The wired remote controller can monitor the indoor and outdoor units' status and display the detected result as a relevant ID.

For details of the display method, refer to the Chapter of "Display Sensor Values" in the *Installation Manual* of Wired Remote Controller (Touch Panel).

The status can be monitored and displayed on the wired remote controller by assigning an arbitrary ID. For available ID list, refer to the table below.

NOTE: Operating time for each part cannot be reset when the part is replaced. Take notes of the operating time before replacing to count the operating time of the replaced part.

Available Sensor ID				
Sensor ID		Item	Unit	Remarks
00: Indoor unit				
00	000	Suction temp.	01: °F or °C	
00	001	Room temp.	01: °F or °C	When the wired remote controller thermistor is enabled, temperature of the wired remote controller thermistor is displayed.
00	002	Wired remote controller detected temp.	01: °F or °C	
00	006	Heat exchanger middle temp.	01: °F or °C	
00	020	Fan rotation number	03: rpm	
00	051	Float switch On/Off	08: On/Off	0: Off, 1: On (When the water level rises)
00	052	Drain pump On/Off	08: On/Off	0: Off, 1: On
00	080	Indoor unit total energized hours	11: h	
00	081	Total filtering hours	11: h	
00	082	Indoor unit fan total operation hours	11: h	
00	140	Operation or Stop (External input)	00: —	0: Off, 1: On —: When the function setting 46 is not set NOTE: Available only for external input port of the indoor unit
00	142	Forced stop (External input)	00: —	0: Off, 1: On —: When the function setting 46 is not set NOTE: Available only for external input port of the indoor unit
00	143	Operation or Stop 2 (External input)	00: —	0: Off, 1: On —: When the function setting 46 is not set NOTE: Available only for external input port of the indoor unit
00	155	Operation or Stop On/Off (External output)	00: —	0: Off, 1: On NOTE: The value is output even if the function setting or rotary switch is not set.
00	156	Error On/Off (External output)	00: —	0: Off, 1: On NOTE: The value is output even if the function setting or rotary switch is not set.
00	157	Indoor unit fan interlocking On/Off (External output)	00: —	0: Off, 1: On NOTE: The value is output even if the function setting or rotary switch is not set.

Available Sensor ID				
Sensor ID		Item	Unit	Remarks
00	158	Cooling thermostat On/Off (External output)	00: —	0: Off, 1: On NOTE: The value is output even if the function setting or rotary switch is not set.
00	159	Requested cooling strength On/Off (External output)	00: —	0: Off, 1: On NOTE: The value is output even if the function setting or rotary switch is not set.
00	160	External heater On/Off (External output)	00: —	0: Off, 1: On NOTE: The value is output even if the function setting or rotary switch is not set.
00	161	Heating operation status (External output)	00: —	0: Off, 1: On NOTE: The value is output even if the function setting or rotary switch is not set.
00	162	External output command by remote controller (External output)	00: —	0: Off, 1: On NOTE: The value is output even if the function setting or rotary switch is not set.
01: Outdoor unit				
01	000	Outdoor temp.	01: °F or °C	
01	001	Discharge temp.	01: °F or °C	
01	003	Heat exchanger middle temp.	01: °F or °C	
01	004	Heat exchanger outlet temp.	01: °F or °C	
01	007	Compressor temp.	01: °F or °C	
01	050	Fan 1 rotation number	03: rpm	
01	055	Compressor rotation number	04: rps	
01	060	Expansion valve (Upstream during heating)	05: pls	
01	080	4-way valve output status	07: Cooling/ Heating	0: Cooling, 1: Heating
01	100	Operating current	09: A	
01	110	Outdoor unit total power-on hours	11: h	
01	111	Compressor total heating operation hours	11: h	
01	112	Compressor total cooling operation hours	11: h	
01	113	Compressor total operation hours	11: h	
01	114	Outdoor unit fan 1 total operation hours	11: h	

7. Various protections

7-1. Discharge gas temperature over-rise prevention control

The discharge gas temperature sensor (discharge thermistor: outdoor unit side) detects the discharge gas temperature.

- When the discharge temperature becomes higher than the trigger condition, the compressor frequency is decreased as the table below, and it continues to decrease until the discharge temperature becomes lower than the trigger condition.
- When the discharge temperature becomes lower than the release condition, control of compressor frequency is released.
- When the discharge temperature becomes higher than the compressor protection temperature, the compressor is stopped and the indoor unit indicator lamp starts blinking.

Trigger condition	219.2°F (104°C)
Compressor frequency	-20 rps/120 seconds
Release condition	213.8°F (101°C)
Compressor protection temperature	230.0°F (110°C)

7-2. Anti-freezing control (cooling and dry mode)

The rotation number of compressor is decrease in cooling and dry mode when the indoor unit heat exchanger temperature sensor detects the temperature lower than the trigger condition.

When the indoor unit heat exchanger temperature reaches release condition, the anti-freezing control is stopped.

Trigger condition		39.2°F (4°C)
Release condition	Outdoor temp. \geq 50°F (10°C)*1	44.6°F (7°C)
	Outdoor temp. \geq 53.6°F (12°C)*2	
	Outdoor temp. $<$ 50°F (10°C)*1	55.4°F (13°C)
	Outdoor temp. $<$ 53.6°F (12°C)*2	

*1: During the outdoor temperature dropping

*2: During the outdoor temperature rising

7-3. Current release control

The rotation number of compressor is controlled so that the outdoor unit input current does not exceeds current limit value set according to the outdoor temperature.

The rotation number of compressor returns according to the operation mode, when the current becomes lower than the release value.

■ Model: AOUH12LUAS1

Operation mode	Outdoor temp. (Ta)	Trigger condition	Release condition
Cooling	$122.0^{\circ}\text{F} (50^{\circ}\text{C}) \leq \text{Ta}$	4.5 A	4.0 A
	$114.8^{\circ}\text{F} (46^{\circ}\text{C}) \leq \text{Ta} < 122.0^{\circ}\text{F} (50^{\circ}\text{C})$	4.5 A	4.0 A
	$104.0^{\circ}\text{F} (40^{\circ}\text{C}) \leq \text{Ta} < 114.8^{\circ}\text{F} (46^{\circ}\text{C})$	6.0 A	5.5 A
	$53.6^{\circ}\text{F} (12^{\circ}\text{C}) \leq \text{Ta} < 104.0^{\circ}\text{F} (40^{\circ}\text{C})$	8.5 A	8.0 A
	$35.6^{\circ}\text{F} (2^{\circ}\text{C}) \leq \text{Ta} < 53.6^{\circ}\text{F} (12^{\circ}\text{C})$	8.5 A	8.0 A
	$\text{Ta} < 35.6^{\circ}\text{F} (2^{\circ}\text{C})$	8.5 A	8.0 A
Heating	$62.6^{\circ}\text{F} (17^{\circ}\text{C}) \leq \text{Ta}$	7.0 A	6.5 A
	$53.6^{\circ}\text{F} (12^{\circ}\text{C}) \leq \text{Ta} < 62.6^{\circ}\text{F} (17^{\circ}\text{C})$	9.0 A	8.5 A
	$41.0^{\circ}\text{F} (5^{\circ}\text{C}) \leq \text{Ta} < 53.6^{\circ}\text{F} (12^{\circ}\text{C})$	10.0 A	9.5 A
	$\text{Ta} < 41.0^{\circ}\text{F} (5^{\circ}\text{C})$	10.0 A	9.5 A

7-4. Indoor unit fan motor over temperature protection

The fan motor over temperature protection activates after two judgments when fulfilling any of the following conditions.

- Detected that the rotation number of the fan motor stays 300 rpm or less for 10 seconds after 90 seconds from the fan operation started.
- IPM trip protection activates.
- Current overload protection activates.

At first, the function determines if any of the above conditions apply (First judgment). If any of the above conditions apply after the first judgment, the function will make the second judgment after 6 minutes. If any of the above conditions still apply in the second judgment, fan motor over temperature protection activates.

• Protection details

The function lowers the static pressure by 20 Pa. If the problem is not resolved even at the minimum static pressure, the unit operates as follows.

- Fan motor error will be displayed if the fan motor speed stays 300 rpm or less for 10 seconds after 90 seconds from the fan operation started.
- The fan stops 40 seconds after the activation of the IPM trip protection.
- The fan stops 50 seconds after the activation of the current overload protection.

7-5. Compressor temperature protection

When the compressor temperature sensor detects higher than the trigger condition below, the compressor is stopped. When the compressor temperature sensor detects the release condition, the protection is released.

Trigger condition	226.4°F (108°C)
Release condition	176.0°F (80°C) (3 minutes after compressor stop)

7-6. Low outdoor temperature protection

When the outdoor temperature sensor detects lower than the trigger condition below, the compressor is stopped.

Operation mode	Cooling/Dry
Trigger condition	5°F (-15°C)
Release condition	14°F (-10°C)

7-7. High temperature and high pressure release control

The compressor is controlled as follows.

■ Model: AOUH12LUAS1

• Cooling mode

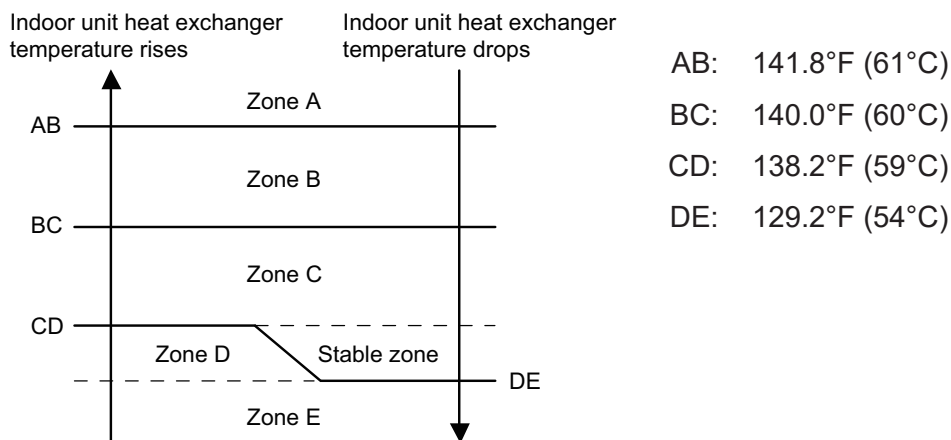

Zone	Operation	
Zone A	Compressor is stopped.	
Zone B	The compressor frequency is decreased.	-30 rps/30 sec.
Zone C		-5 rps/60 sec.
Zone D	The protection is released and the operation is returned to normal mode.	
Zone E		

• Heating mode

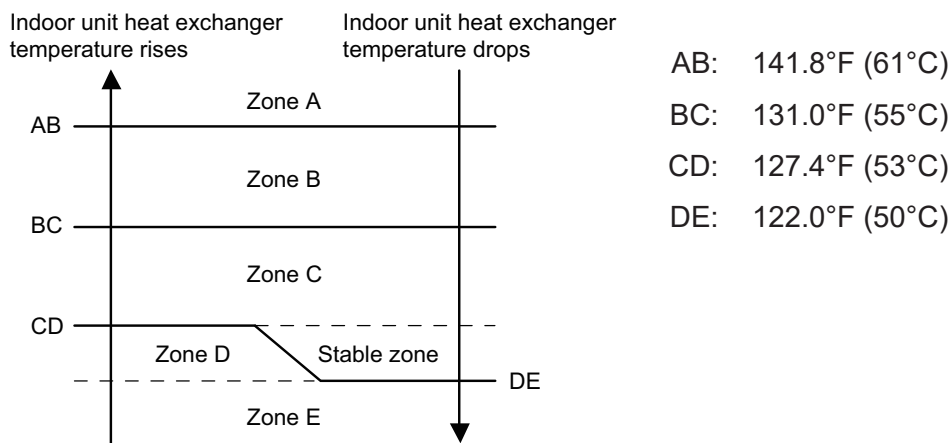

Zone	Operation	
Zone A	Compressor is stopped.	
Zone B	The compressor frequency is decreased.	-25 rps/120 sec.
Zone C		-3 rps/60 sec.
Zone D	The protection is released and the operation is returned to normal mode.	
Zone E		

5. FILED WORKING

CONTENTS

5. FILED WORKING

1. Function settings	05-1
1-1. Function settings on indoor unit.....	05-1
1-2. Function settings by using remote controller	05-3
2. External input and output.....	05-12
2-1. External input.....	05-12
2-2. External output	05-14
2-3. Combination of external input and output	05-16
2-4. Details of function	05-19

1. Function settings

To adjust the functions of this product according to the installation environment, various types of function settings are available.

NOTE: Incorrect settings can cause a product malfunction.

1-1. Function settings on indoor unit

By using some components on the PCB, you can change the function settings.

Related components on the PCB and the applicable settings:

Component		Setting content	
DIP switch	SW101	1	Drainage function setting
		2	(Setting prohibited)
		3	Fan delay setting

■ Component location

Components on the indoor unit main PCB used for the function settings are located as shown in the following figure.

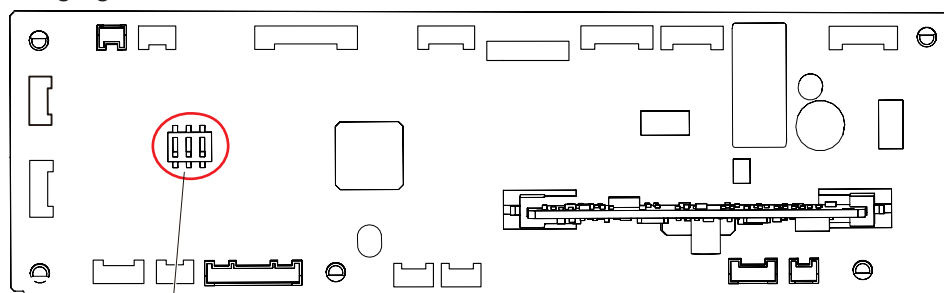

DIP switch 101

■ DIP switch setting

- **SW101-Switch 1: Drainage function setting**

Switch 1	Drainage function	Factory setting
ON	Disabled	
OFF	Enabled	◆

- **SW101-Switch 2: (Setting prohibited)**

- **SW101-Switch 3: Fan delay setting**

When the indoor unit is stopped while operating in conjunction with auxiliary heater, the indoor unit fan operation will continue for 1 minute.

Switch 3	Fan delay	Factory setting
ON	Enabled	
OFF	Disabled	◆

1-2. Function settings by using remote controller

Some function settings can be changed on the remote controller. After confirming the setting procedure and the content of each function setting, select appropriate functions for your installation environment.

■ Setting procedure by using remote controller

Remote controller is not attached for this product. For details of the installing remote controller, refer to following information.

- Overview information: Operating manual of the remote controller
- Setting procedure: Installation manual of the remote controller

■ Contents of function setting

Each function setting listed in this section is adjustable in accordance with the installation environment.

NOTE: Setting will not be changed if invalid numbers or setting values are selected.

● Function setting list

	Function no.	Functions
1)	11	Filter sign
2)	26	Static pressure
3)	30/31	Room temperature control for indoor unit sensor
4)	35/36	Room temperature control for wired remote controller sensor
5)	40	Auto restart
6)	42	Room temperature sensor switching
7)	43	Cold air prevention
8)	44	Remote controller custom code
9)	46	External input control
10)	48	Room temperature sensor switching (Aux.)
11)	49	Indoor unit fan control for energy saving for cooling
12)	60	Switching functions for external output terminal
13)	61	Control switching of external heaters
14)	62	Operating temperature switching of external heaters
15)	66	Outdoor temperature zone boundary temperature A
16)	67	Outdoor temperature zone boundary temperature B
17)	71	Standby time for auxiliary equipment operation
18)	72	Heat pump backup setting
19)	73	Emergency heat for external output terminal
20)	74	Fan delay time
21)	75	External heater use in defrosting

1) Filter sign

Select appropriate intervals for displaying the filter sign on the indoor unit according to the estimated amount of dust in the air of the room.

If the indication is not required, select "No indication" (03).

Function number	Setting value	Setting description	Factory setting
11	00	Standard (2,500 hours)	
	01	Long interval (4,400 hours)	
	02	Short interval (1,250 hours)	
	03	No indication	◆

2) Static pressure

Select the appropriate static pressure according to the installation conditions.

Function number	Setting value	Setting description	Factory setting
26	03	0.12 inWG (30 Pa)	
	04	0.16 inWG (40 Pa)	
	05	0.20 inWG (50 Pa)	
	06	0.24 inWG (60 Pa)	
	07	0.28 inWG (70 Pa)	
	08	0.32 inWG (80 Pa)	
	09	0.36 inWG (90 Pa)	
	10	0.40 inWG (100 Pa)	
	11	0.44 inWG (110 Pa)	
	12	0.48 inWG (120 Pa)	
	13	0.52 inWG (130 Pa)	
	14	0.56 inWG (140 Pa)	
	15	0.60 inWG (150 Pa)	
	16	0.64 inWG (160 Pa)	
	17	0.68 inWG (170 Pa)	
	18	0.72 inWG (180 Pa)	
	19	0.76 inWG (190 Pa)	
	20	0.80 inWG (200 Pa)	
	31	Standard 0.18 inWG (45 Pa)	◆
	32	Automatic airflow adjustment	

NOTE: Range of static pressure is different by model.

Model name	Range of static pressure
ARUH12LUAS	0.12 to 0.8 inWG (30 to 200 Pa)

3) Room temperature control for indoor unit sensor

NOTE: If the remote sensor unit option is selected, perform this setting.

Depending on the installed environment, correction of the room temperature sensor may be required. Select the appropriate control setting according to the installed environment.

The temperature of the room temperature sensor is corrected as follows:

Corrected temp. = Temp. of the room temp. sensor - Correction temp. value

Example of correction:

When the temperature of the room temp. sensor is 78°F and the setting value is "03" (-2°F), the corrected temp. will be 80°F (78°F - [-2°F]).

The temperature correction values show the difference from the Standard setting "00" (manufacturer's recommended value).

Function number		Setting value	Setting description	Factory setting	
30 (For cooling)	31 (For heating)	00	Standard setting	◆	
		01	No correction 0.0 °F (0.0 °C)		
		02	-1 °F (-0.5 °C)	More cooling Less heating	
		03	-2 °F (-1.0 °C)		
		04	-3 °F (-1.5 °C)		
		05	-4 °F (-2.0 °C)		
		06	-5 °F (-2.5 °C)		
		07	-6 °F (-3.0 °C)		
		08	-7 °F (-3.5 °C)		
		09	-8 °F (-4.0 °C)		
		10	+1 °F (+0.5 °C)	Less cooling More heating	
		11	+2 °F (+1.0 °C)		
		12	+3 °F (+1.5 °C)		
		13	+4 °F (+2.0 °C)		
		14	+5 °F (+2.5 °C)		
		15	+6 °F (+3.0 °C)		
		16	+7 °F (+3.5 °C)		
17	+8 °F (+4.0 °C)				

4) Room temperature control for wired remote controller sensor

Depending on the installed environment, correction of the wire remote temperature sensor may be required. Select the appropriate control setting according to the installed environment.

To change this setting, set Function 42 to "Both" (01).

Ensure that the Thermo Sensor icon is displayed on the remote controller screen.

Function number		Setting value	Setting description	Factory setting	
35 (For cooling)	36 (For heating)	00	Standard setting	◆	
		01	No correction 0.0 °F (0.0 °C)		
		02	-1 °F (-0.5 °C)	More cooling Less heating	
		03	-2 °F (-1.0 °C)		
		04	-3 °F (-1.5 °C)		
		05	-4 °F (-2.0 °C)		
		06	-5 °F (-2.5 °C)		
		07	-6 °F (-3.0 °C)		
		08	-7 °F (-3.5 °C)		
		09	-8 °F (-4.0 °C)		
		10	+1 °F (+0.5 °C)	Less cooling More heating	
		11	+2 °F (+1.0 °C)		
		12	+3 °F (+1.5 °C)		
		13	+4 °F (+2.0 °C)		
		14	+5 °F (+2.5 °C)		
		15	+6 °F (+3.0 °C)		
		16	+7 °F (+3.5 °C)		
17	+8 °F (+4.0 °C)				

5) Auto restart

Enables or disables automatic restart after a power interruption.

Function number	Setting value	Setting description	Factory setting
40	00	Enable	◆
	01	Disable	

NOTE: Auto restart is an emergency function such as for power outage etc. Do not attempt to use this function in normal operation. Be sure to operate the unit by remote controller or external device.

6) Room temperature sensor switching

(Only for wired remote controller)

When using the wired remote controller temperature sensor, change the setting to "Both" (01).

Function number	Setting value	Setting description	Factory setting
42	00	Indoor unit	◆
	01	Both	

00: Sensor on the indoor unit is active.

01: Sensors on both indoor unit and wired remote controller are active.

NOTE: Remote controller sensor must be turned on by using the remote controller.

7) Cold air prevention

This setting is to disable the cold air prevention function during heating operation. When disabled, the fan setting will always follow the setting on the remote controller. (Excluding defrost mode)

Function number	Setting value	Setting description	Factory setting
43	00	Enable	◆
	01	Disable	

8) Remote controller custom code

(Only for wireless remote controller)

The indoor unit custom code can be changed. Select the appropriate custom code.

Function number	Setting value	Setting description	Factory setting
44	00	A	◆
	01	B	
	02	C	
	03	D	

9) External input control

"Operation/Stop" mode or "Forced stop" mode can be selected.

Function number	Setting value	Setting description	Factory setting
46	00	Operation/Stop mode 1	◆
	01	(Setting prohibited)	
	02	Forced stop mode	
	03	Operation/Stop mode 2	

10) Room temperature sensor switching (Aux.)

To use the temperature sensor on the wired remote controller only, change the setting to "Wired remote controller" (01).

This function will only work if the function setting 42 is set at "Both" (01).

When the setting value is set to "Both" (00), more suitable control of the room temperature is possible by setting function setting 30 and 31 too.

Function number	Setting value	Setting description	Factory setting
48	00	Both	◆
	01	Wired remote controller	

11) Indoor unit fan control for energy saving for cooling

Enables or disables the power-saving function by controlling the indoor unit fan rotation when the outdoor unit is stopped during cooling operation.

Function number	Setting value	Setting description	Factory setting
49	00	Disable	
	01	Enable	
	02	Remote controller	◆

00: When the outdoor unit is stopped, the indoor unit fan operates continuously following the setting on the remote controller.

01: When the outdoor unit is stopped, the indoor unit fan operates intermittently at a very low speed.

02: Enable or disable this function by remote controller setting.

NOTES:

- As the factory setting, this setting is initially invalidated.
- Set to "00" or "01" when connecting a remote controller that cannot set the Fan control for energy saving function or connecting a network converter.
To confirm if the remote controller has this setting, refer to the operating manual of each remote controller.

12) Switching functions for external output terminal

Functions of the external output terminal can be switched. For details, refer to "External input and output".

Function number	Setting value	Setting description	Factory setting
60	00	Operation status	◆
	01—04	Cooling thermostat On	
	05	Heating operation	
	06	Operation/Stop	
	07—08	Cooling thermostat On	
	09	Error status	
	10	Indoor unit fan operation status	
	11	External heater	

13) Control switching of external heaters

Sets the control method for external heater to be used.

For details, refer to "External heater output" in [Chapter 2-4. "Details of function"](#) on page 05-19.

Function number	Setting value	Setting description	Factory setting
61	00	Auxiliary heater control 1	◆
	01	Auxiliary heater control 2	
	02	Heat pump prohibition control	
	03	Auxiliary heater control by outdoor temperature 1	
	04	Auxiliary heater control by outdoor temperature 2	
	05	Auxiliary heater control by outdoor temperature 3	
	06	Auxiliary heat pump control	
	07	Auxiliary heat pump control by outdoor temperature 1	
	08	Auxiliary heat pump control by outdoor temperature 2	
	09	Auxiliary heat pump control by outdoor temperature 3	

14) Operating temperature switching of external heaters

Sets the temperature conditions when the external heater is ON.

For details, refer to "External heater output" in [Chapter 2-4. "Details of function"](#) on page 05-19.

Function number	Setting value	Setting description				Factory setting
		Setting value of function 61:				
		00		01 to 09		
		Heater: On	Heater: Off	Heater: On	Heater: Off	
62	00	-5.4 °F (-3 °C)	-1.8 °F (-1 °C)	-0.9 °F (-0.5 °C)	0.9 °F (0.5 °C)	◆
	01	-3.6 °F (-2 °C)	-1.8 °F (-1 °C)	-1.8 °F (-1 °C)	0.9 °F (0.5 °C)	
	02	-3.6 °F (-2 °C)	-1.8 °F (-1 °C)	-3.6 °F (-2 °C)	0.9 °F (0.5 °C)	
	03	-5.4 °F (-3 °C)	-1.8 °F (-1 °C)	-5.4 °F (-3 °C)	0.9 °F (0.5 °C)	
	04	-7.2 °F (-4 °C)	-1.8 °F (-1 °C)	-7.2 °F (-4 °C)	0.9 °F (0.5 °C)	
	05	-9.0 °F (-5 °C)	-1.8 °F (-1 °C)	-9.0 °F (-5 °C)	0.9 °F (0.5 °C)	
	06	-5.4 °F (-3 °C)	-0.9 °F (-0.5 °C)	-0.9 °F (-0.5 °C)	0 °F (0 °C)	
	07	-3.6 °F (-2 °C)	-0.9 °F (-0.5 °C)	-1.8 °F (-1 °C)	0 °F (0 °C)	
	08	-3.6 °F (-2 °C)	-0.9 °F (-0.5 °C)	-3.6 °F (-2 °C)	0 °F (0 °C)	
	09	-5.4 °F (-3 °C)	-0.9 °F (-0.5 °C)	-5.4 °F (-3 °C)	0 °F (0 °C)	
	10	-7.2 °F (-4 °C)	-0.9 °F (-0.5 °C)	-7.2 °F (-4 °C)	0 °F (0 °C)	
	11	-9.0 °F (-5 °C)	-0.9 °F (-0.5 °C)	-9.0 °F (-5 °C)	0 °F (0 °C)	
	12	-5.4 °F (-3 °C)	0 °F (0 °C)	-0.9 °F (-0.5 °C)	-0.9 °F (-0.5 °C)	
	13	-3.6 °F (-2 °C)	0 °F (0 °C)	-1.8 °F (-1 °C)	-0.9 °F (-0.5 °C)	
	14	-3.6 °F (-2 °C)	0 °F (0 °C)	-3.6 °F (-2 °C)	-0.9 °F (-0.5 °C)	
	15	-5.4 °F (-3 °C)	0 °F (0 °C)	-5.4 °F (-3 °C)	-0.9 °F (-0.5 °C)	
	16	-7.2 °F (-4 °C)	0 °F (0 °C)	-7.2 °F (-4 °C)	-0.9 °F (-0.5 °C)	
17	-9.0 °F (-5 °C)	0 °F (0 °C)	-9.0 °F (-5 °C)	-0.9 °F (-0.5 °C)		

15) Outdoor temperature zone boundary temperature A

Setting required if changing of the outdoor temperature setting for heat pump prohibition zone is required when auxiliary heater control by outdoor temperature 1 and 2 are performed on the indoor unit. For details, refer to "External heater output" in [Chapter 2-4. "Details of function"](#) on page 05-19.

Function number	Setting value	Setting description	Factory setting
66	00	-4.0 °F (-20 °C)	◆
	01	-0.4 °F (-18 °C)	
	02	3.2 °F (-16 °C)	
	03	6.8 °F (-14 °C)	
	04	10.4 °F (-12 °C)	
	05	14.0 °F (-10 °C)	
	06	17.6 °F (-8 °C)	
	07	21.2 °F (-6 °C)	
	08	24.8 °F (-4 °C)	

16) Outdoor temperature zone boundary temperature B

Setting required if changing of the outdoor temperature setting for heat pump only zone is required when auxiliary heater control by outdoor temperature 1 is performed on the indoor unit. For details, refer to "External heater output" in [Chapter 2-4. "Details of function"](#) on page 05-19.

Function number	Setting value	Setting description	Factory setting
67	00	42.8 °F (6 °C)	◆
	01	14.0 °F (-10 °C)	
	02	17.6 °F (-8 °C)	
	03	21.2 °F (-6 °C)	
	04	24.8 °F (-4 °C)	
	05	28.4°F (-2 °C)	
	06	32.0 °F (0 °C)	
	07	35.6 °F (2 °C)	
	08	39.2 °F (4 °C)	
	09	42.8 °F (6 °C)	
	10	46.4 °F (8 °C)	
	11	50.0 °F (10 °C)	
	12	53.6 °F (12 °C)	
	13	57.2 °F (14 °C)	
	14	60.8 °F (16 °C)	
15	64.4 °F (18 °C)		

17) Standby time for auxiliary equipment operation

Sets the standby time until the auxiliary equipment operation starts during primary equipment operation.

For details, refer to [Chapter 2-4. "Details of function"](#) on page 05-19.

Function number	Setting value	Setting description	Factory setting
71	00	Disable	◆
	01	1 minute	
	02	2 minutes	
	•	•	
	•	•	
	•	•	
	98	98 minutes	
	99	99 minutes	

18) Heat pump backup setting

Enables or disables the heat pump backup instruction from the outdoor unit.

This function will be usable provided that the corresponding outdoor unit is connected.

Function number	Setting value	Setting description	Factory setting
72	00	Disable	◆
	01	Enable	

19) Emergency heat for external output terminal

Enables or disables emergency heat input.

Function number	Setting value	Setting description	Factory setting
73	00	Disable	◆
	01	Enable	

NOTE: When this function is used, IR Receiver Unit is necessary.

20) Fan delay time

Sets the fan delay time when the heater is turned off.

Function number	Setting value	Setting description	Factory setting
74	00	1 minute	◆
	01	50 seconds	
	02	40 seconds	
	03	30 seconds	

21) External heater use in defrosting

Enables or disables external heater use in defrosting.

NOTE: Inappropriate heater selection may cause cold air in defrosting.

Function number	Setting value	Setting description	Factory setting
75	00	Disable	◆
	01	Enable	

2. External input and output

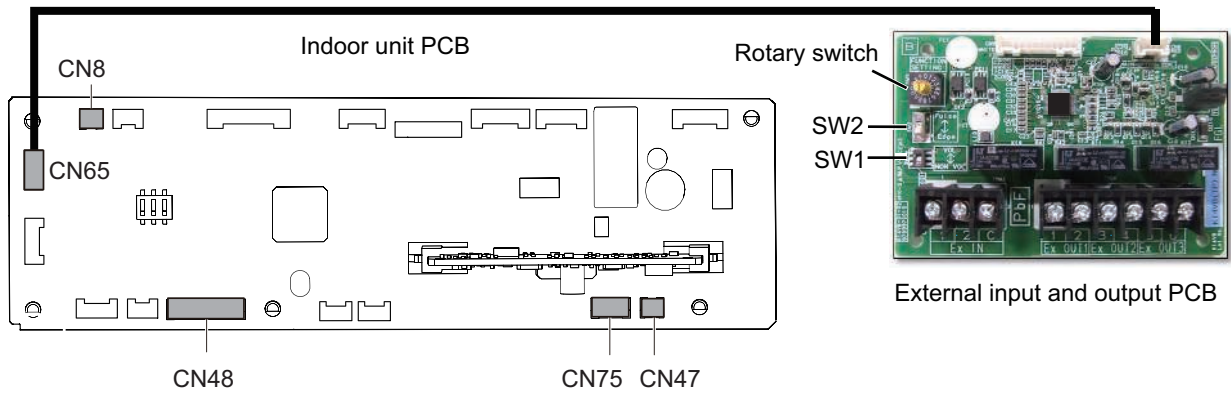

PCB	External input	External output	Connector	Input select	Input signal	External connect kit (Optional parts)
Indoor unit	Operation/Stop Forced stop	—	Terminal	Dry contact	Edge	—
	—	Operation status	CN47	—	—	UTY-XWZXZG
		Error status				
		Indoor unit fan operation status				
—	External heater output	CN47	—	—	—	
External input and output (UTY-XCSX)	Operation/Stop	—	Input 1/ Input 2	Dry contact/ Apply voltage	Edge/ Pulse	—
	Forced thermostat off		Input 1		Edge	
	—	Operation status	Output 1 Output 2 Output 3	—	—	—
		Error status				
Indoor unit fan operation status						
External heater output						

2-1. External input

- "Operation/Stop" mode or "Forced stop" mode can be selected with function setting of indoor unit.
- A twisted pair cable (22AWG) should be used. Maximum length of cable is 492 ft (150 m).
- The wire connection should be separate from the power cable line.

Indoor unit functions such as Operation/Stop can be done by using indoor unit terminals.

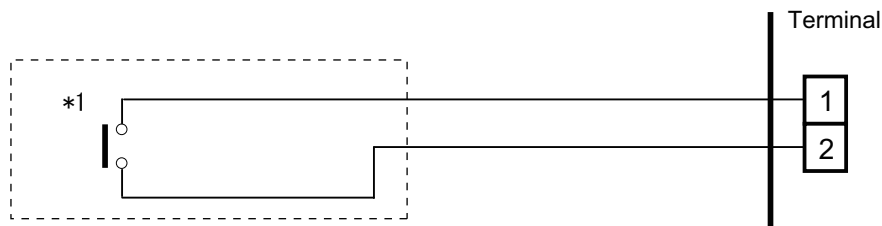

*1: The switch can be used on the following condition: DC 12 V to 24 V, 1 mA to 15 mA.

External input and output PCB

The indoor unit Operation/Stop can be set by using the input terminal on the PCB.

Input select

Use either one of these types of terminals according to the application. (Both types of terminals cannot be used simultaneously.)

- Dry contact

In case of internal power supply, set the slide switch of SW1 to "NON VOL" side.

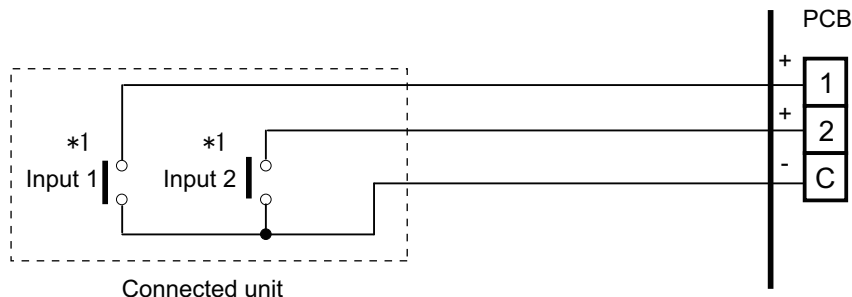

*1: The switches can be used on the following condition: DC 12 V to 24 V, 1 mA to 15 mA.

- Apply voltage

In case of external power supply, set the slide switch of SW1 to "VOL" side.

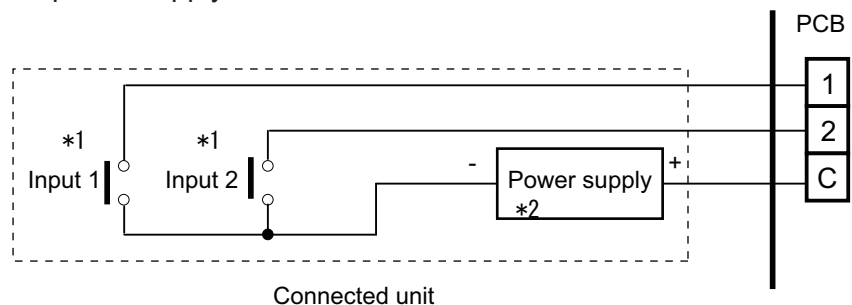

*1: The switches can be used on the following condition: DC 12 V to 24 V, 1 mA to 15 mA.

*2: Make the power supply DC 12 V to 24 V 10 mA or more.

2-2. External output

Use an external output cable with appropriate external dimension, depending on the number of cables to be installed.

- A twisted pair cable (22AWG) should be used. Maximum length of cable is 82 ft (25 m).
- Output voltage: High DC 12 V \pm 2 V, Low 0 V.
- Permissible current: 50 mA
- For details, refer to ["Combination of external input and output"](#) on page 05-16.

● When indicator, etc. are connected directly

Example: Function setting 60 is set to "00"

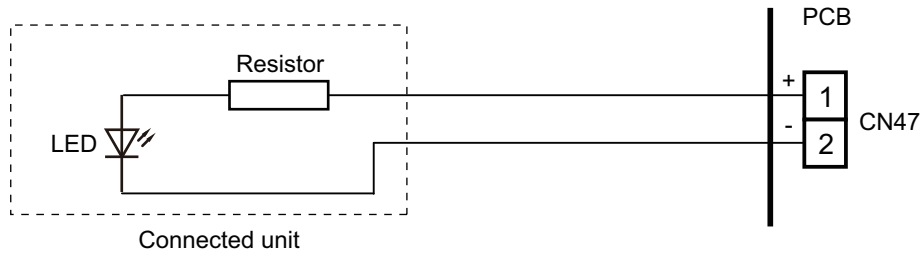

● When connecting with a device equipped with a power supply

Example: Function setting 60 is set to "00"

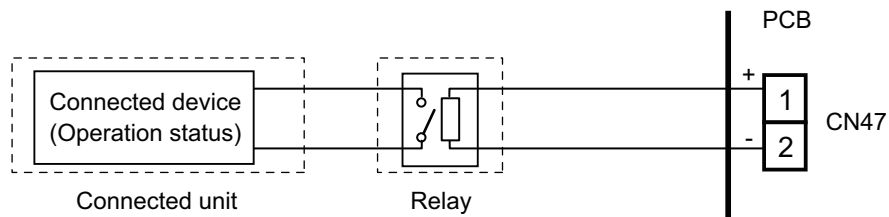

External input and output PCB

- A twisted pair cable (22AWG) should be used.
- Permissible voltage and current: DC 5 V to 30 V / 3 A, AC 30 V to 250 V / 3 A
- For details, refer to [Chapter 2-3. "Combination of external input and output"](#) on page 05-16.

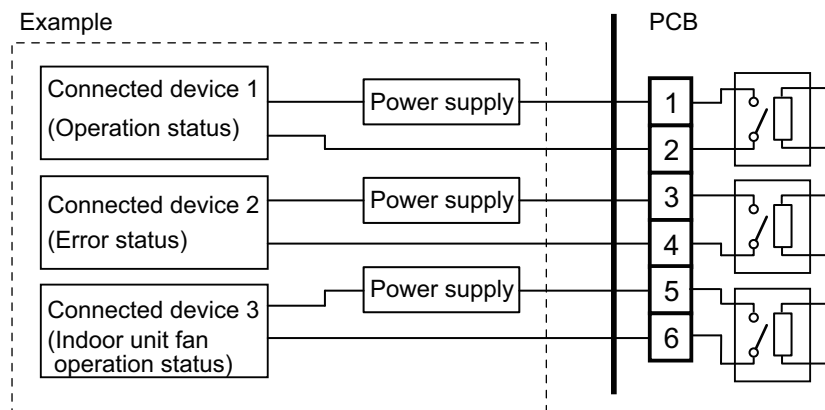

2-3. Combination of external input and output

By combining the function setting of the indoor unit and rotary switch setting of the External input and output PCB, you can select various combinations of functions.

Combination examples of external input and output are as follows:

Mode	Function setting	External input and output PCB (Rotary SW)	External input			
			Indoor unit Input	External input and output PCB		
			Terminal	Input 1	Input 2	Signal type
0-1	60-00	1	Operation/Stop (Function setting 46-00) or Forced stop (Function setting 46-02)	Operation/Stop	Not available	Edge
				Operation	Stop	Pulse
0-2	60-00	2		Forced Thermostat OFF	Not available	Edge
1	60-01	3		Mechanical cooling Off		
2	60-02	4		Forced thermostat Off		
3	60-03	5		Mechanical cooling On		
4	60-04	6		Mechanical cooling On		
5	60-05	7		Forced thermostat Off		
6	60-06	8		Forced thermostat Off		
7	60-07	9		Mechanical cooling Off		
8	60-08	A		Forced thermostat Off		
9	60-09	B		Forced Thermostat OFF		
10	60-10	C	Forced Thermostat OFF			
11	60-11	D	Forced Thermostat OFF			
12	60-12	D	Forced Thermostat OFF			

Mode	Function setting	External input and output PCB (Rotary SW)	External output			
			Indoor unit Output	External input and output PCB		
			CN47	Output 1	Output 2	Output 3
0-1	60-00	1	Operation/Stop	Operation/Stop	Error status	Indoor unit fan operation status
0-2	60-00	2	Operation/Stop	Error status	Indoor unit fan operation status	External heater output
1	60-01	3	Cooling thermostat On	Error status	Indoor unit fan operation status	External heater output
2	60-02	4	Cooling thermostat On	Error status	Remote controller output	External heater output
3	60-03	5	Cooling thermostat On	Cooling high/low output	Remote controller output	External heater output
4	60-04	6	Cooling thermostat On	Error status	Remote controller output	Cooling high/low output
5	60-05	7	Heating thermostat On	Error status	Indoor unit fan operation status	External heater output
6	60-06	8	Operation/Stop	Error status	Indoor unit fan operation status	Heating thermostat On
7	60-07	9	Cooling thermostat On	Error status	Heating thermostat On	External heater output
8	60-08	A	Cooling thermostat On	Heating thermostat On	Remote controller output	External heater output
9	60-09	B	Error status	Operation/Stop	Indoor unit fan operation status	External heater output
10	60-10	C	Indoor unit fan operation status	Operation/Stop	Error status	External heater output
11	60-11	D	External heater output	Operation/Stop	Indoor unit fan operation status	Error status
12	60-12	D	Setpoint Attainment status	Operation/Stop	Indoor unit fan operation status	Error status

NOTE: Input of Operation/Stop depends on the setting of function setting 46.

00: Operation/Stop mode 1 (Remote controller enabled)

01: (Setting prohibited)

02: Forced stop

03: Operation/Stop mode 2 (Remote controller disabled)

■ Input signal type

- Indoor unit
Input signal type is only "Edge".

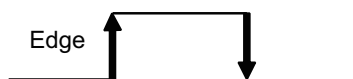

- External input and output PCB
The input signal type can be selected.
Signal type (edge or pulse) can be switched by the DIP switch 2 (SW2) on the External input and output PCB.

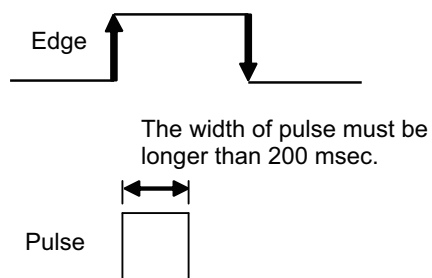

2-4. Details of function

■ Control input function

● When function setting is "Operation/Stop" mode 1

- In the case of "Edge" input

Function setting /	Rotary SW of External input and output PCB	External input		Input signal	Command
46-00	-	Input of indoor unit	Terminal	Off → On	Operation
				On → Off	Stop
	60-00 / 1	External input and output PCB	Input 1	Off → On	Operation
				On → Off	Stop

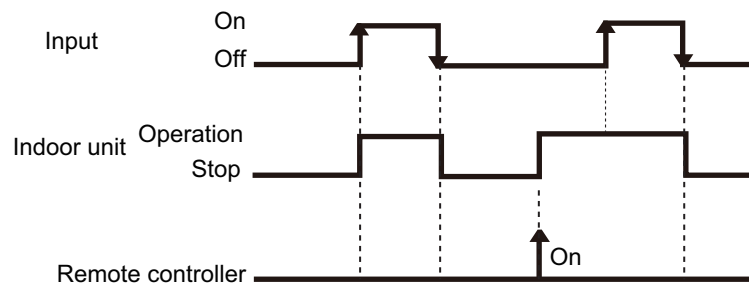

- In the case of "Pulse" input

Function setting /	Rotary SW of External input and output PCB	External input		Input signal	Command
46-00	60-00 / 1	External input and output PCB	Input 1	Pulse	Operation
			Input 2	Pulse	Stop

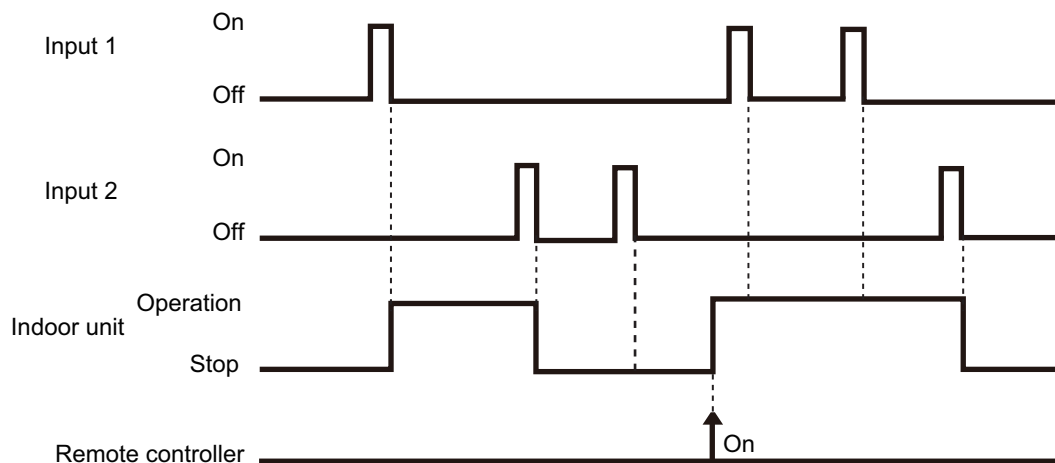

NOTES:

- The last command has priority.
- The indoor units within the same remote controller group operates in the same mode.

● When function setting is "Forced stop" mode

- In the case of "Edge" input

Function setting /		Rotary SW of External input and output PCB		External input		Input signal	Command
46-02	-	Input of indoor unit	Terminal	Off → On	Forced stop		
				On → Off	Normal		
	60-00 / 1	External input and output PCB	Input 1	Off → On	Forced stop		
				On → Off	Normal		

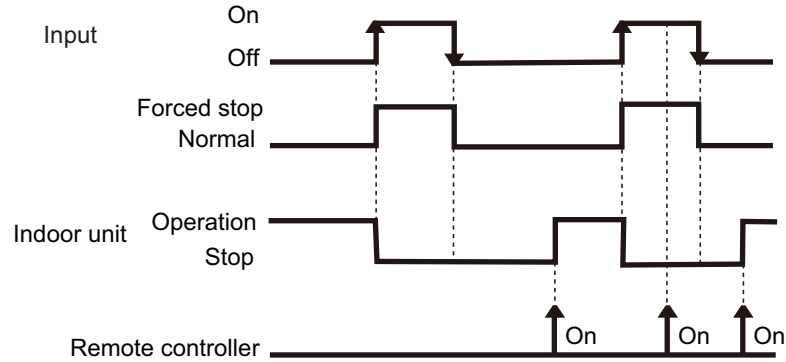

- In the case of "Pulse" input

Function setting /		Rotary SW of External input and output PCB		External input		Input signal	Command
46-02	60-00 / 1	External input and output PCB	Input 1	Pulse	Forced stop		
			Input 2	Pulse	Normal		

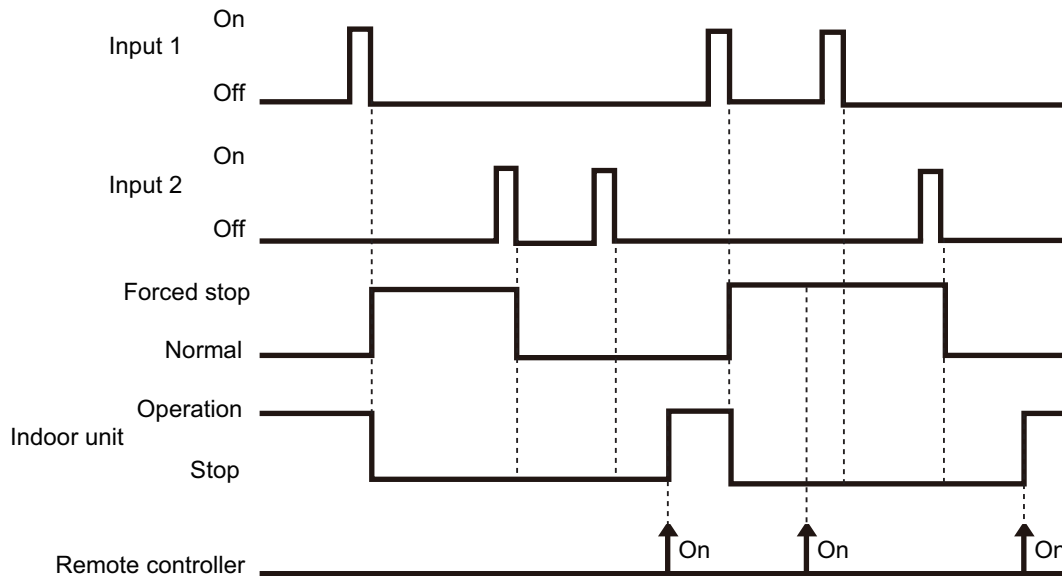

NOTES:

- When the forced stop is triggered, indoor unit stops and Operation/Stop operation by the remote controller is restricted.
- When forced stop function is used with forming a remote controller group, connect the same equipment to each indoor unit within the group.

● When function setting is "Operation/Stop" mode 2

- In the case of "Edge" input

Function setting /	Rotary SW of External input and output PCB	External input		Input signal	Command
46-03	-	Input of indoor unit	Terminal	Off → On	Operation
				On → Off	Stop (Remote controller disabled)
	60-00 / 1	External input and output PCB	Input 1	Off → On	Operation
				On → Off	Stop (Remote controller disabled)

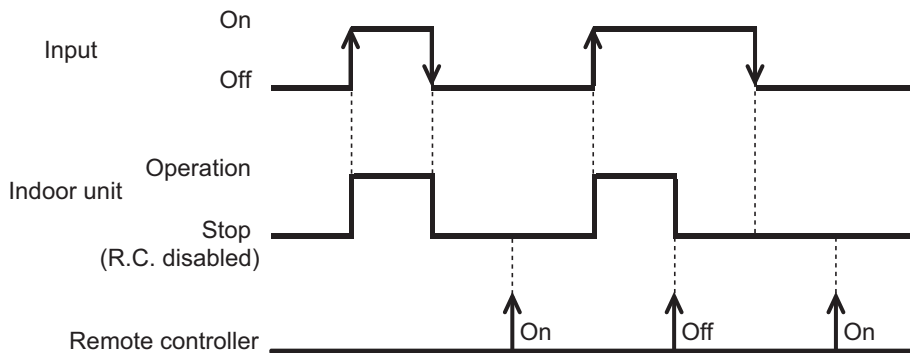

- In the case of "Pulse" input

Function setting /	Rotary SW of External input and output PCB	External input		Input signal	Command
46-03	60-00 / 1	External input and output PCB	Input 1	Pulse	Operation
			Input 2	Pulse	Stop (Remote controller disabled)

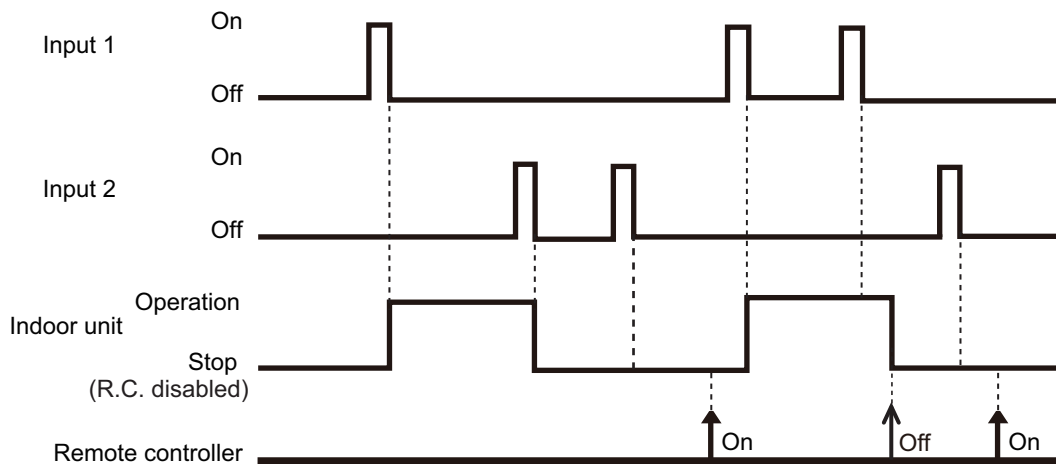

NOTES:

- When "Operation/Stop" mode 2 function is used with forming a remote controller group, connect the same equipment to each indoor unit within the group.

■ Forced thermostat off function

Function setting /	Rotary SW of External input and output PCB	External input		Input signal	Command
60-00 / 2 60-02 / 4 60-05 / 7 60-06 / 8 60-08 / A 60-09 / B 60-10 / C 60-11 / D		External input and output PCB	Input 1	Off → On	Thermostat off
				On → Off	Normal operation

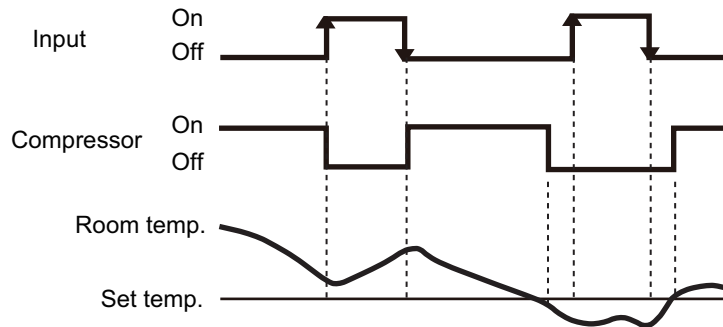

■ Control output function

Function setting /	Rotary SW of External input and output PCB	External output		Output signal	Command
60-00 / 1, 2 60-06 / 8		Output of indoor unit	CN47	Low → High	Operation
				High → Low	Stop
60-00 / 1 60-09 / B 60-10 / C 60-11 / D		External input and output PCB	Output 1	Off → On	Operation
				On → Off	Stop

The output is low when the unit is stopped.

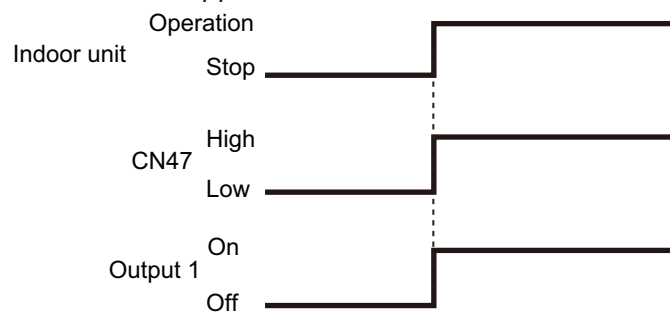

■ Error status

Function setting / Rotary SW of External input and output PCB	External output	Output signal	Command		
60-09 / B	Output of indoor unit	Low → High	Error		
		High → Low	Normal		
60-00 / 2 60-01 / 3 60-02 / 4 60-04 / 6 60-05 / 7 60-06 / 8 60-07 / 9	External input and output PCB	Output 1	Off → On	Error	
			On → Off	Normal	
		Output 2	Off → On	Error	
			On → Off	Normal	
		60-00 / 1 60-10 / C	Output 3	Off → On	Error
				On → Off	Normal
		60-11 / D			

The output is ON when an error is generated for the indoor unit.

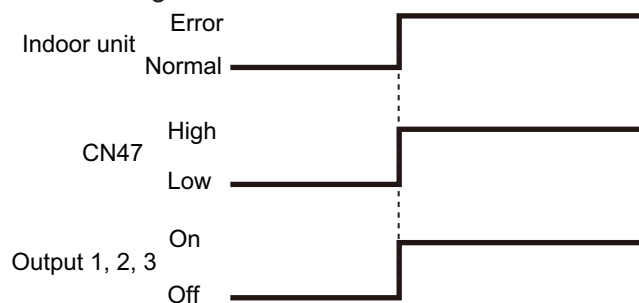

■ Indoor unit fan operation status

Function setting / Rotary SW of External input and output PCB	External output	Output signal	Command	
60-10 / C	Output of indoor unit	CN47	Low → High	Fan run
			High → Low	Fan stop
60-00 / 2 60-01 / 3 60-05 / 7 60-06 / 8 60-09 / B 60-11 / D	External input and output PCB	Output 2	Off → On	Fan run
			On → Off	Fan stop
			Off → On	Fan run
			On → Off	Fan stop
60-00 / 1	Output 3	Off → On	Fan run	
		On → Off	Fan stop	

Output signal	Condition
On Low → High	The indoor unit fan is operating.
Off High → Low	The fan is stopped or during cold air prevention. During thermostat off when in dry mode operation.

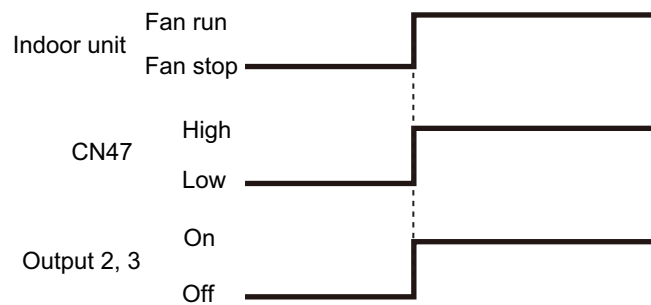

■ External heater output

Control	Primary heater	Auxiliary heater	Function setting
			Indoor unit
			Control switching external heaters No. 61
Auxiliary heater control 1	Heat pump	External device* ¹	61-00
Auxiliary heater control 2	Heat pump	External device	61-01
Heat pump prohibition control	External device	None	61-02
Auxiliary heater control by outdoor temperature 1	Heat pump	External device	61-03
Auxiliary heater control by outdoor temperature 2	Heat Pump	External device	61-04
Auxiliary heater control by outdoor temperature 3	Heat Pump	External device	61-05
Auxiliary heat pump control	External device	Heat pump	61-06
Auxiliary heat pump control by outdoor temperature 1	External device	Heat pump	61-07
Auxiliary heat pump control by outdoor temperature 2	External device	Heat pump	61-08
Auxiliary heat pump control by outdoor temperature 3	External device	Heat pump	61-09

NOTES:

- After turning off the heater, 3 minutes of standby time is required by next power-on of the heater.
- For items marked “—” in the table, any of validate or invalidate of the setting are acceptable.
- *1: External device means Hot water, Electrical heater, etc.

● Installation configuration of individual connection

External heating device is installed individually. (No use of indoor unit fan)

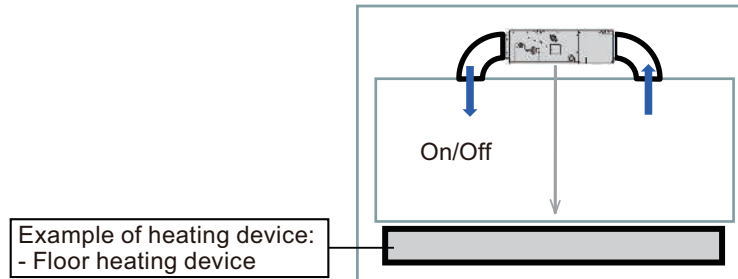

⚠ WARNING

DIP switch 101-3 must be in the ON position when ducted electric heat application is being used. DIP switch 101-3 is set in the ON position by default from the factory. When DIP switch 101-3 is in the ON position and ducted electric heat application is not being used, cold draft occurs due to fan delay off operation.

Operation			Condition
Heater off	DIP-SW101-3	On	<ul style="list-style-type: none"> • Heater is off as shown in following diagram of heating temperature. • Other than heating mode • Error occurred • Forced thermostat off • Fan stop protection
	Indoor unit fan setting for external heater	Enabled	
	DIP-SW101-3	Off	<ul style="list-style-type: none"> • Heater is off as shown in following diagram of heating temperature. • Other than heating mode • Error occurred • Forced thermostat off
	Indoor unit fan setting for external heater	Disabled	

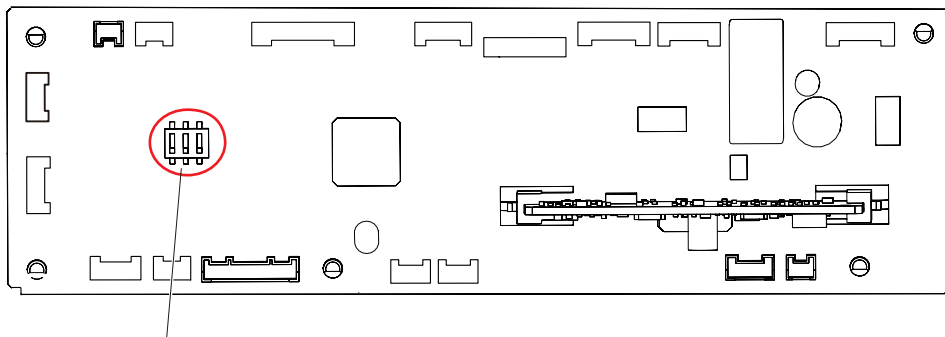

DIP switch 101

- Design and install external heater appropriately with considering its protection.

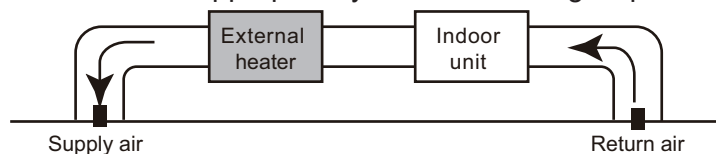

- Inappropriate designing and installation of external heater may cause a fire by emitted heat from the external heater.
- Fujitsu General Ltd. is not responsible for inappropriate designing or installation of external heating device.

● Auxiliary equipment control by room temperature

Auxiliary equipment control is switchable by room temperature. Auxiliary equipment switching is performed for each room temperature divided to following 3 zones.

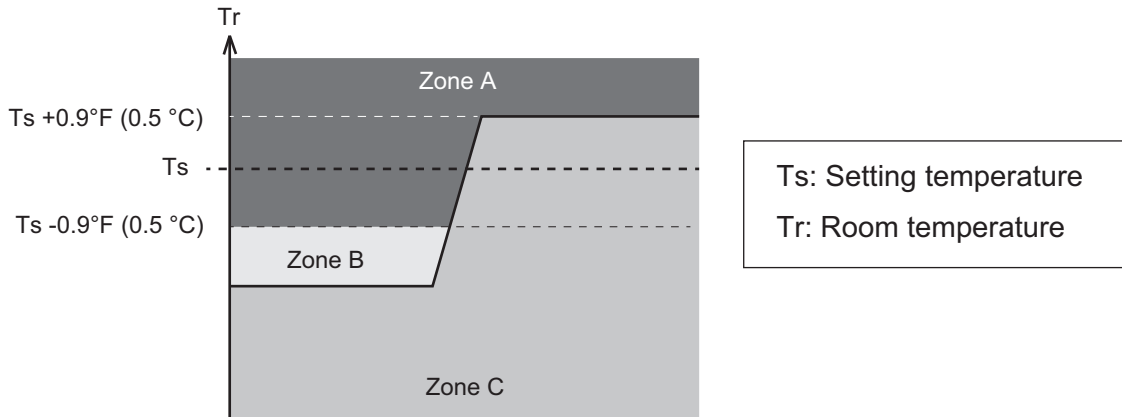

Zone	Application	When temperature dropping		When temperature rising	
		Primary	Auxiliary	Primary	Auxiliary
A	Both of primary and auxiliary equipment is unnecessary.	Off	Off	Off	Off
B	Primary heater only. When room temperature stays in zone B for a long time, auxiliary equipment also operates.	On	Off*1	—	—
C	Auxiliary equipment also operates.	On	On*2	On	On*2

*1: For standby time for auxiliary equipment operation, refer to indoor unit function number 71 "[Contents of function setting](#)" on page 05-3.

*2: When indoor unit function number 61 is set to "00", auxiliary equipment operates according to the following conditions.

- $T_s - T_r > 21.6 \text{ }^\circ\text{F}$ ($-12.0 \text{ }^\circ\text{C}$): Auxiliary equipment turn off.
- $T_s - T_r > 18.0 \text{ }^\circ\text{F}$ ($-10.0 \text{ }^\circ\text{C}$): Auxiliary equipment turn on.

● Auxiliary heater control 1

Operation	Condition
Heater on	Heater is on as shown in following diagram of heating temperature.
Heater off	<ul style="list-style-type: none"> • Heater is off as shown in following diagram of heating temperature. • Other than heating mode • Error occurred • Forced thermostat off • Fan stop protection

- Temperature of heater on (Thon): Adjustable by function number 62 (Operating temperature switching of external heaters).
- All control temperatures will shift by adjusting “Thon”.

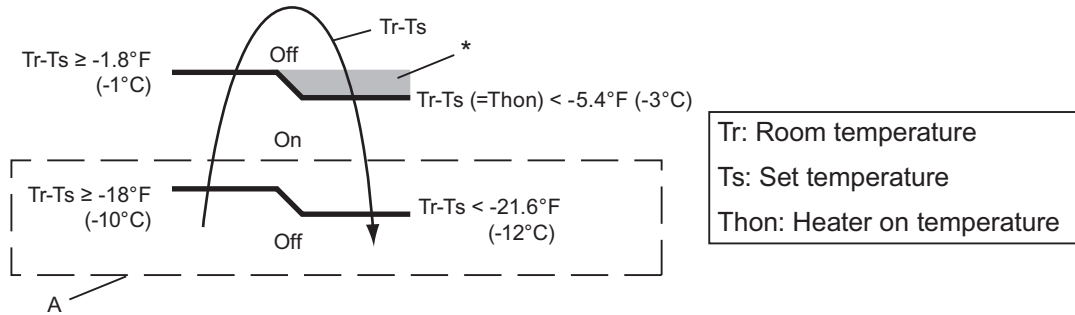

*: When room temperature stays in this zone for a specific time, auxiliary heater is turned on. For details, refer to function number 71.

Example: When set temperature (Ts) is 72°F (22°C) (Factory setting),

- and room temperature (Tr) increases above 53.6°F (12°C), signal output is on.
- and room temperature (Tr) increases above 69.8°F (21°C), signal output is off.
- and room temperature (Tr) decreases below 66.2°F (19°C), signal output is on.
- and room temperature (Tr) decreases below 50°F (10°C), signal output is off.

● Auxiliary heater control 2

Control that excludes “A” from "Auxiliary heater control 1" on page 05-28.

Operation	Condition
Heater on	Heater is on as shown in following diagram of heating temperature.
Heater off	<ul style="list-style-type: none"> • Heater is off as shown in following diagram of heating temperature. • Other than heating mode • Error occurred • Forced thermostat off • Fan stop protection

- Temperature of heater on (Thon): Adjustable by function number 62 (Operating temperature switching of external heaters).
- All control temperatures will shift by adjusting “Thon”.

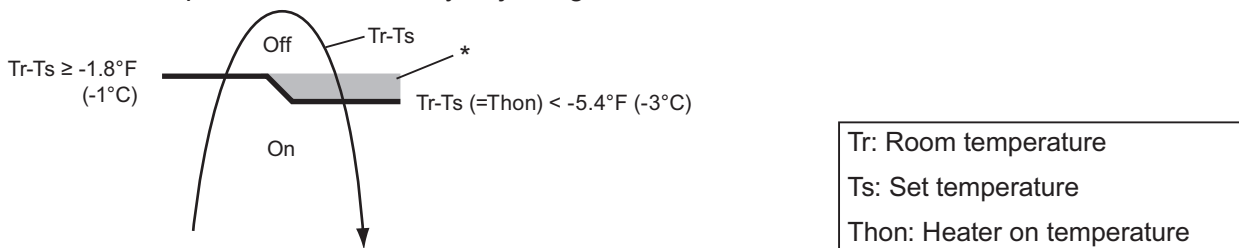

*: When room temperature stays in this zone for a specific time, auxiliary heater is turned on. For details, refer to function number 71.

● Heat pump prohibition control

Perform heating by external heater only. Indoor unit is continuous thermostat off.

Operation			Condition
Heater on			Heater is on as shown in following diagram of heating temperature.
Heater off	DIP-SW101-3 On Indoor unit fan setting for external heater	On Enabled	<ul style="list-style-type: none"> • Heater is off as shown in following diagram of heating temperature. • Other than heating mode • Error occurred • Forced thermostat off • Fan stop protection
	DIP-SW101-3 Off Indoor unit fan setting for external heater	Off Disabled	<ul style="list-style-type: none"> • Heater is off as shown in following diagram of heating temperature. • Other than heating mode • Error occurred • Forced thermostat off

- Temperature of heater on (Thon): Adjustable by function number 62 (Operating temperature switching of external heaters).
- All control temperatures will shift by adjusting “Thon”.

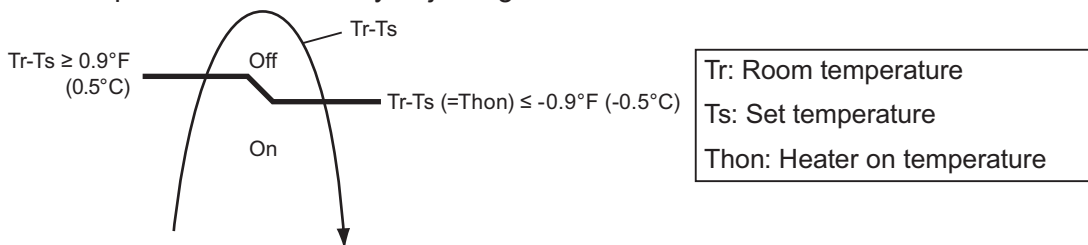

• Operation status

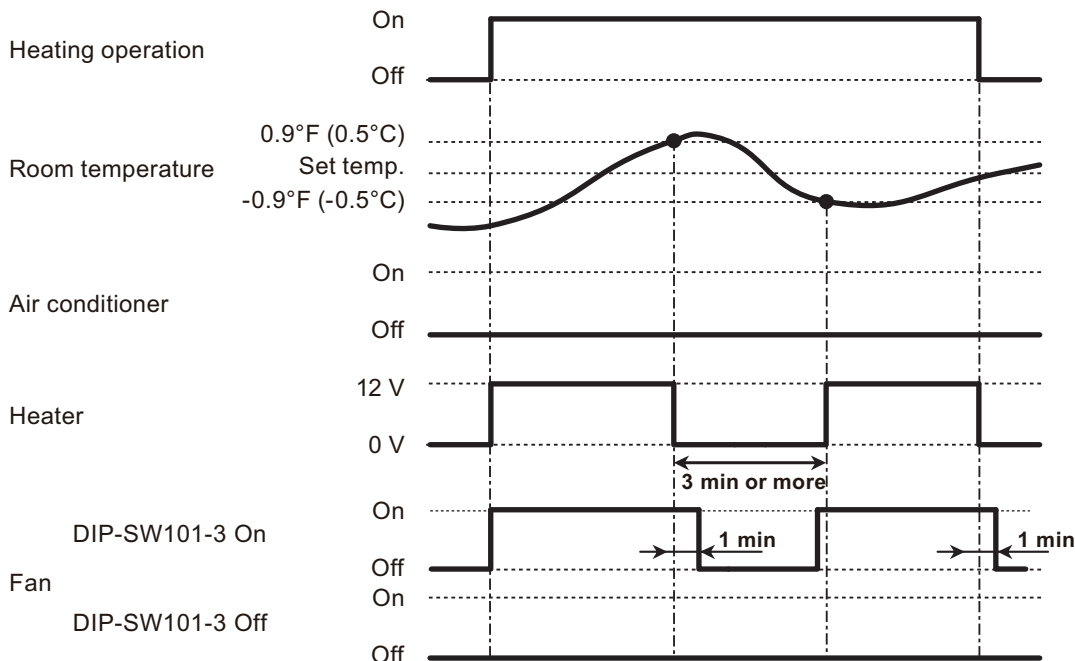

NOTE: In following operations, compressor will be on.

- Other than heating
- Test run

● Auxiliary heater control by outdoor temperature 1

This control selects heat pump or external heater according to the outdoor temperature. When outdoor temperature is high, the heating is performed by using heat pump only.

Operation			Condition
Heater on			Heater is on as shown in following diagram of heating temperature.
Heater off	DIP-SW101-3 Indoor unit fan setting for external heater	On Enabled	<ul style="list-style-type: none"> • Heater is off as shown in following diagram of heating temperature. • Other than heating mode • Error occurred • Forced thermostat off • Heat pump only zone • Fan stop protection
	DIP-SW101-3 Indoor unit fan setting for external heater	Off Disabled	<ul style="list-style-type: none"> • Heater is off as shown in following diagram of heating temperature. • Other than heating mode • Error occurred • Forced thermostat off • Heat pump only zone

- Temperature of heater on (Thon): Adjustable by function number 62 (Operating temperature switching of external heaters).
- All control temperatures will shift by adjusting "Thon".
- Outdoor temperature zone boundary A and B: Adjustable individually by function setting number 66 and 67.

• External heater output

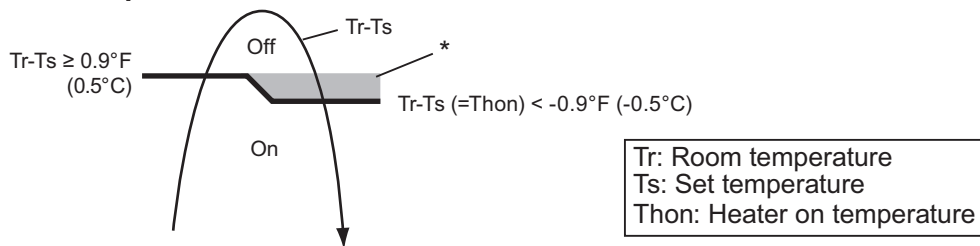

*: When room temperature stays in this zone for a specific time, auxiliary heater is turned on. For details, refer to function number 71.

• Outdoor temperature zone

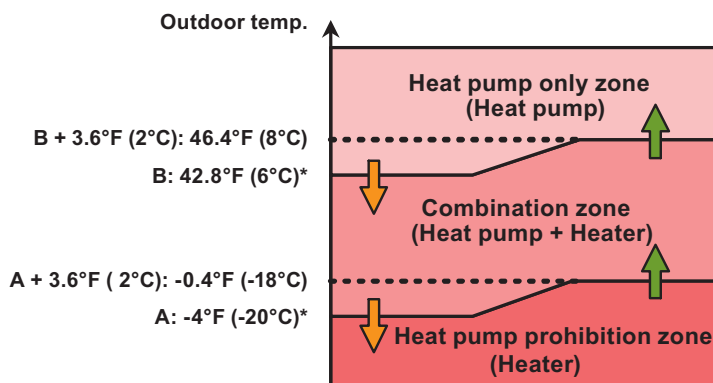

*: Adjustable by function setting 66 and 67

• Operation status

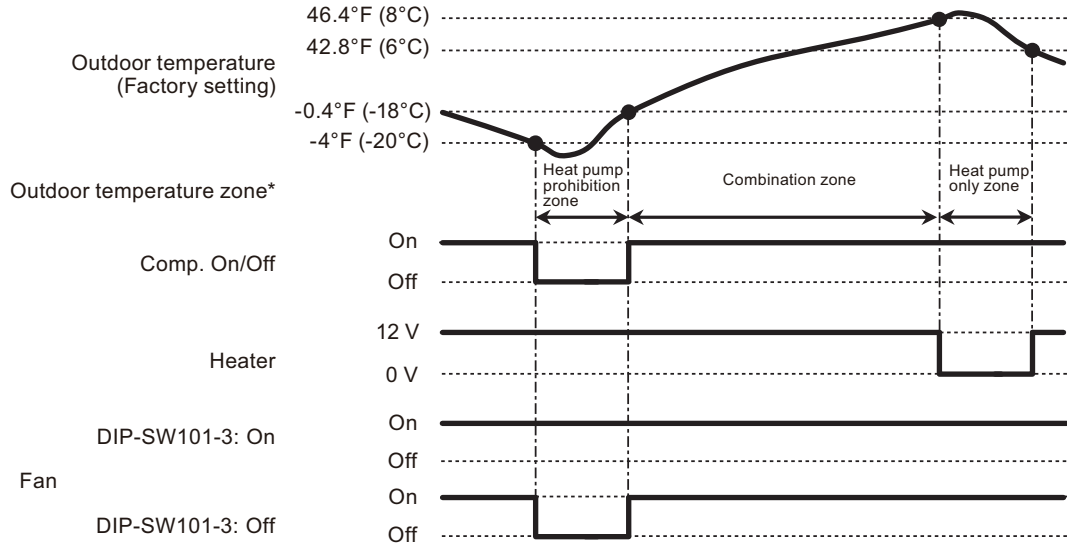

*: The outdoor temperature zone transition from one to another will stay in that zone for minimum of 30 min.

NOTE: In following operations, compressor will be on in heat pump prohibition zone.

- Other than heating
- Test run

FIELD WORKING

FIELD WORKING

● Auxiliary heater control by outdoor temperature 2

This control selects heat pump or external heater according to the outdoor temperature. Even when outdoor temperature is high, the heating is performed by using both of heat pump and external heater.

Operation			Condition
Heater on			Heater is on as shown in following diagram of heating temperature.
Heater off	DIP-SW101-3 Indoor unit fan setting for external heater	On Enabled	<ul style="list-style-type: none"> • Heater is off as shown in following diagram of heating temperature. • Other than heating mode • Error occurred • Forced thermostat off • Fan stop protection
	DIP-SW101-3 Indoor unit fan setting for external heater	Off Disabled	<ul style="list-style-type: none"> • Heater is off as shown in following diagram of heating temperature. • Other than heating mode • Error occurred • Forced thermostat off

- Temperature of heater on (Thon): Adjustable by function number 62 (Operating temperature switching of external heaters).
- All control temperatures will shift by adjusting “Thon”.
- Outdoor temperature zone boundary A: Adjustable by function setting number 66.

• External heater output

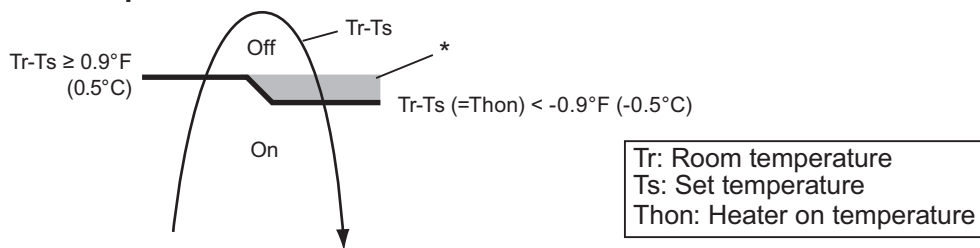

*: When room temperature stays in this zone for a specific time, auxiliary heater is turned on. For details, refer to function number 71.

• Outdoor temperature zone

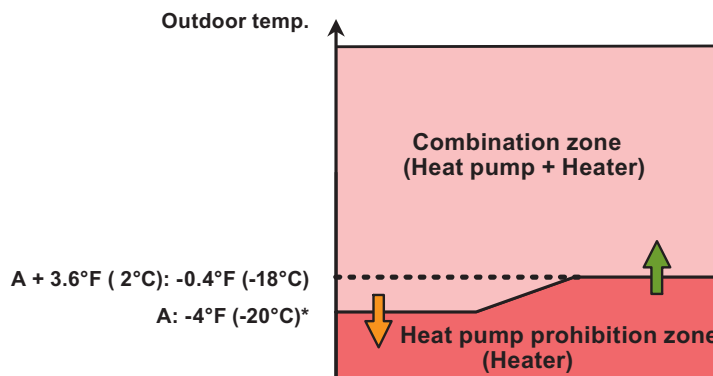

*: Adjustable by function setting 66

• Operation status

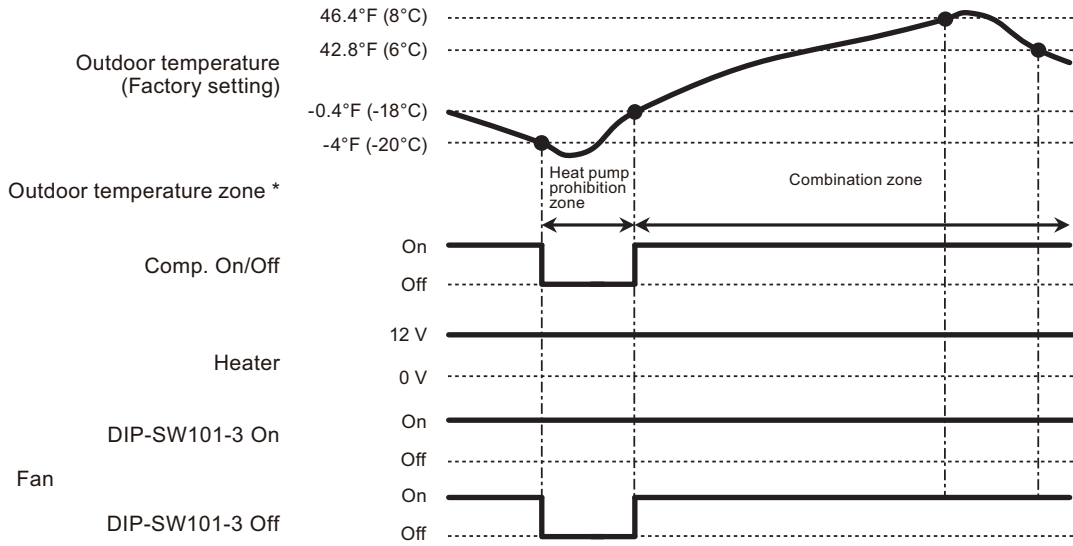

* The outdoor temperature zone transition from one to another will stay in that zone for minimum of 30 min.

NOTE: In following operations, compressor will be on in heat pump prohibition zone.

- Other than heating
- Test run

FIELD WORKING

FIELD WORKING

● Auxiliary heater control by outdoor temperature 3

This control selects heat pump or external heater according to the outdoor temperature. Even when outdoor temperature is high, the heating is performed by using both of heat pump and external heater.

Operation			Condition
Heater on			Heater is on as shown in following diagram of heating temperature.
Heater off	DIP-SW101-3 Indoor unit fan setting for external heater	On Enabled	<ul style="list-style-type: none"> Heater is off as shown in following diagram of heating temperature. Other than heating mode Error occurred Forced thermostat off Fan stop protection
	DIP-SW101-3 Indoor unit fan setting for external heater	Off Disabled	<ul style="list-style-type: none"> Heater is off as shown in following diagram of heating temperature. Other than heating mode Error occurred Forced thermostat off

- Temperature of heater on (Thon): Adjustable by function number 62 (Operating temperature switching of external heaters).
- All control temperatures will shift by adjusting “Thon”.
- Outdoor temperature zone boundary B: Adjustable by function setting number 67.

• External heater output

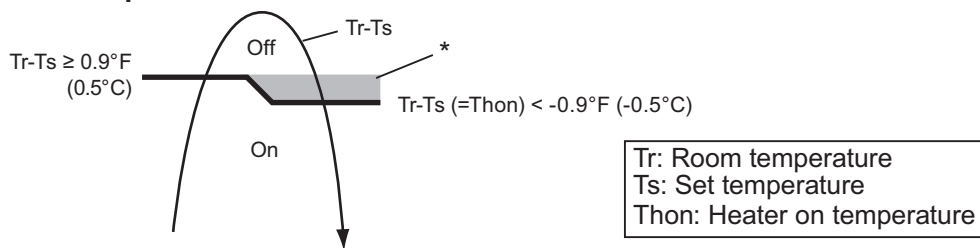

*: When room temperature stays in this zone for a specific time, auxiliary heater is turned on. For details, refer to function number 71.

• Outdoor temperature zone

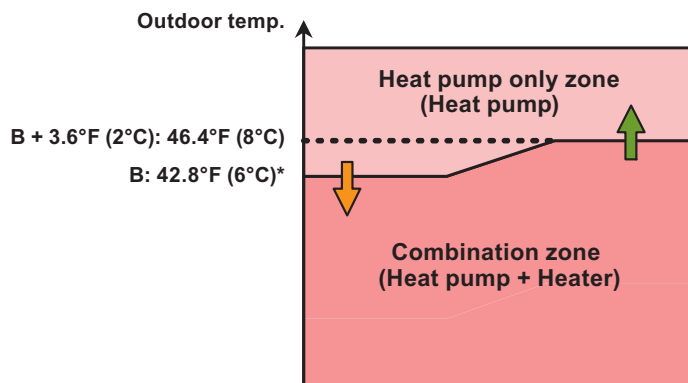

*: Adjustable by function setting 67

FIELD WORKING

FIELD WORKING

• Operation status

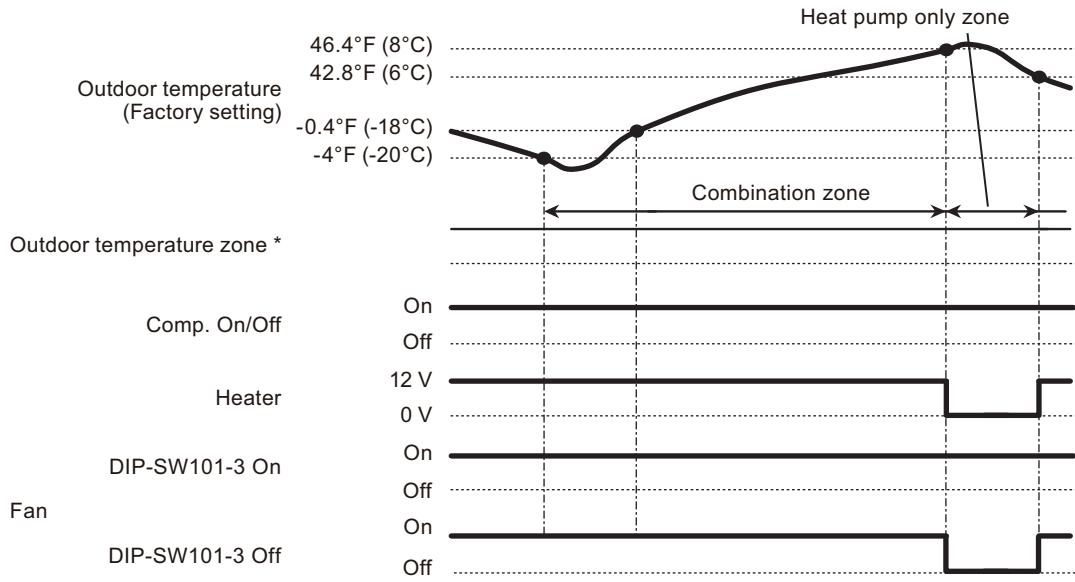

*: The outdoor temperature zone transition from one to another will stay in that zone for minimum of 30 min.

NOTE: In following operations, compressor will be on in heat pump prohibition zone.

- Other than heating
- Test run

FIELD WORKING

FIELD WORKING

● Auxiliary heat pump control

• External heater output

Operation			Condition
Heater on			Heater is on as shown in following diagram of heating temperature.
Heater off	DIP-SW101-3 Indoor unit fan setting for external heater	On Enabled	<ul style="list-style-type: none"> • Heater is off as shown in following diagram of heating temperature. • Other than heating mode • Error occurred • Forced thermostat off • Fan stop protection
	DIP-SW101-3 Indoor unit fan setting for external heater	Off Disabled	<ul style="list-style-type: none"> • Heater is off as shown in following diagram of heating temperature. • Other than heating mode • Error occurred • Forced thermostat off

- Temperature of heater on (Thon): Set temperature (Ts) - 0.9 °F (- 0.5 °C)
- Temperature of heater off: Set temperature (Ts) + 0.9 °F (+ 0.5 °C)

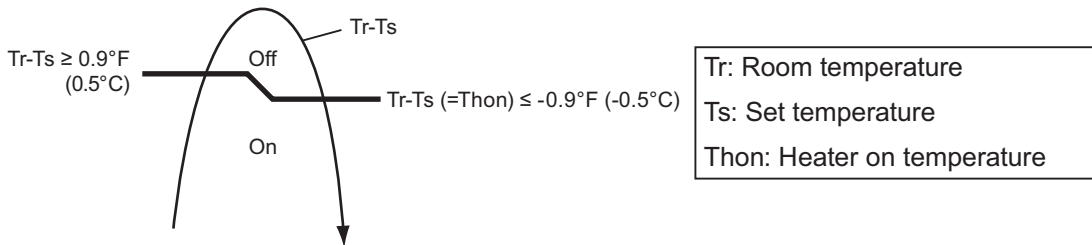

• Auxiliary heat pump On/Off

- Temperature of heater on (Thon): Adjustable by function number 62 (Operating temperature switching of heat pump).
- All control temperatures will shift by adjusting “Thon”.

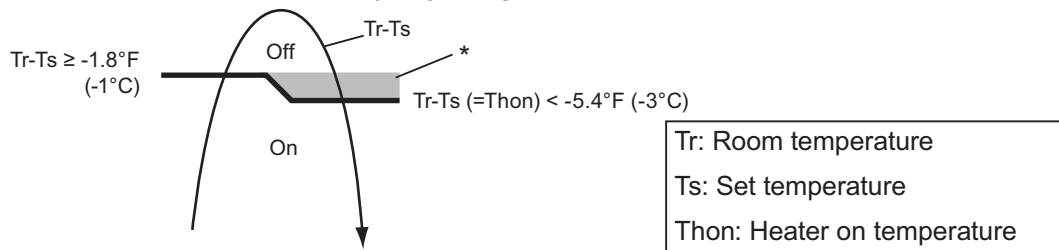

*: When room temperature stays in this zone for a specific time, auxiliary heater is turned on. For details, refer to function number 71.

● Auxiliary heat pump control by outdoor temperature 1

• External heater output

Operation			Condition
Heater on			Heater is on as shown in following diagram of heating temperature.
Heater off	DIP-SW101-3 Indoor unit fan setting for external heater	On Enabled	<ul style="list-style-type: none"> • Heater is off as shown in following diagram of heating temperature. • Other than heating mode • Error occurred • Forced thermostat off • Fan stop protection
	DIP-SW101-3 Indoor unit fan setting for external heater	Off Disabled	<ul style="list-style-type: none"> • Heater is off as shown in following diagram of heating temperature. • Other than heating mode • Error occurred • Forced thermostat off

- Temperature of heater on (Thon): Set temperature (Ts) - 0.9 °F (- 0.5 °C)
- Temperature of heater off: Set temperature (Ts) + 0.9 °F (+ 0.5 °C)

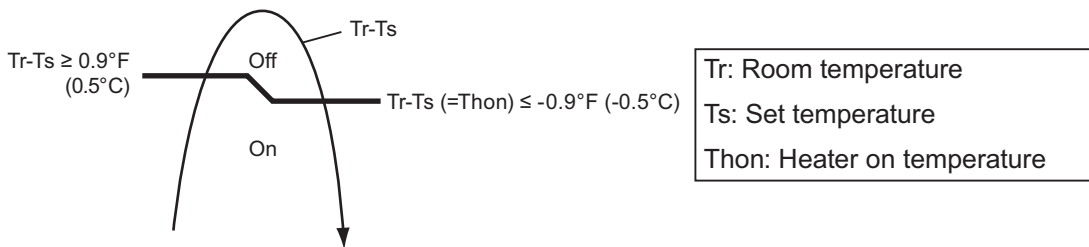

• Auxiliary heat pump On/Off

- Temperature of heater on (Thon): Adjustable by function number 62 (Operating temperature switching of heat pump).
- All control temperatures will shift by adjusting “Thon”.

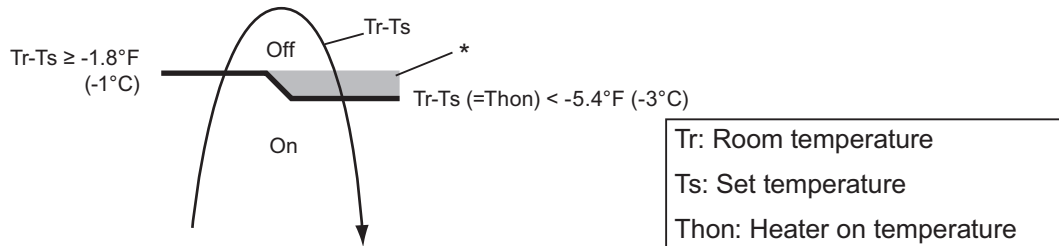

*: When room temperature stays in this zone for a specific time, auxiliary heater is turned on. For details, refer to function number 71.

• Outdoor temperature zone

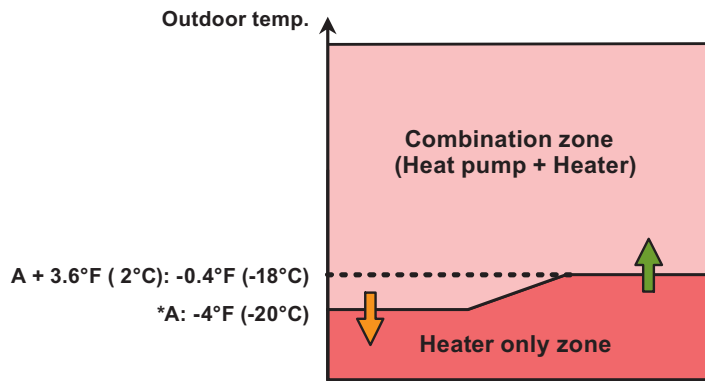

*: Adjustable by function setting 67

• Operation status

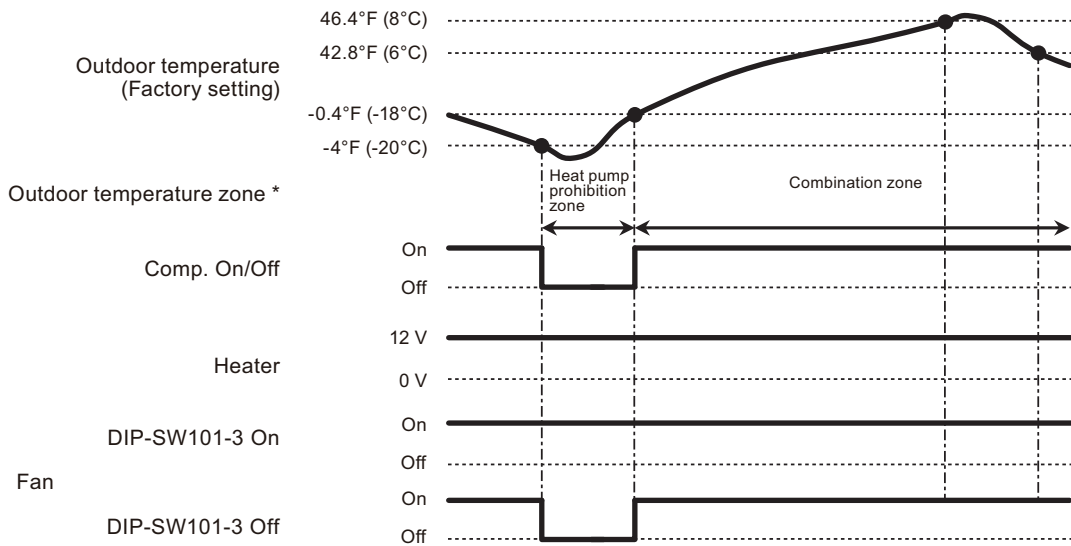

* The outdoor temperature zone transition from one to another will stay in that zone for minimum of 30 min.

NOTE: In following operations, compressor will be on in heat pump prohibition zone.

- Other than heating
- Test run

FIELD WORKING

FIELD WORKING

● Auxiliary heat pump control by outdoor temperature 2

• External heater output

Operation			Condition
Heater on			Heater is on as shown in following diagram of heating temperature.
Heater off	DIP-SW101-3 Indoor unit fan setting for external heater	On Enabled	<ul style="list-style-type: none"> • Heater is off as shown in following diagram of heating temperature. • Other than heating mode • Error occurred • Forced thermostat off • Fan stop protection
	DIP-SW101-3 Indoor unit fan setting for external heater	Off Disabled	<ul style="list-style-type: none"> • Heater is off as shown in following diagram of heating temperature. • Other than heating mode • Error occurred • Forced thermostat off

- Temperature of heater on (Thon): Set temperature (Ts) - 0.9 °F (- 0.5 °C)
- Temperature of heater off: Set temperature (Ts) + 0.9 °F (+ 0.5 °C)

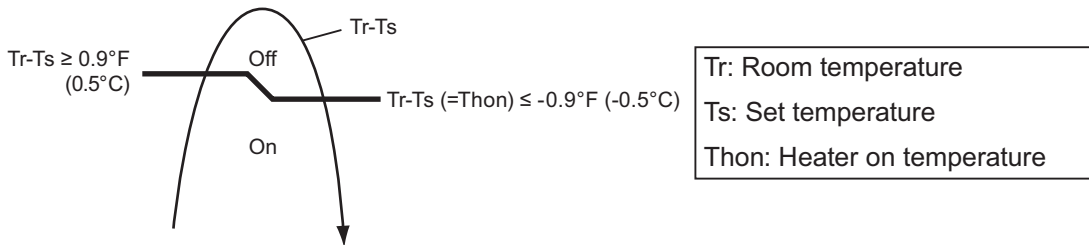

• Auxiliary heat pump On/Off

- Temperature of heater on (Thon): Adjustable by function number 62 (Operating temperature switching of heat pump).
- All control temperatures will shift by adjusting “Thon”.

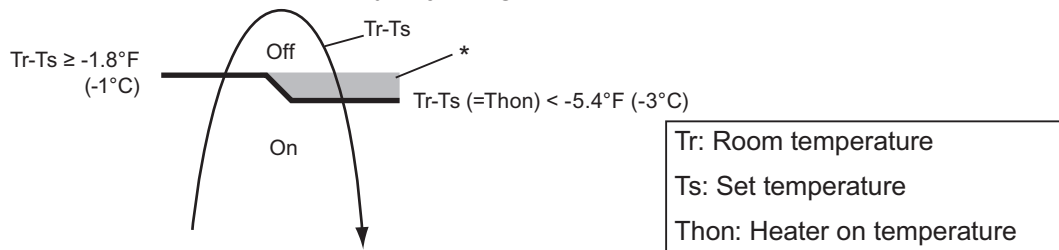

*: When room temperature stays in this zone for a specific time, auxiliary heater is turned on. For details, refer to function number 71.

• Outdoor temperature zone

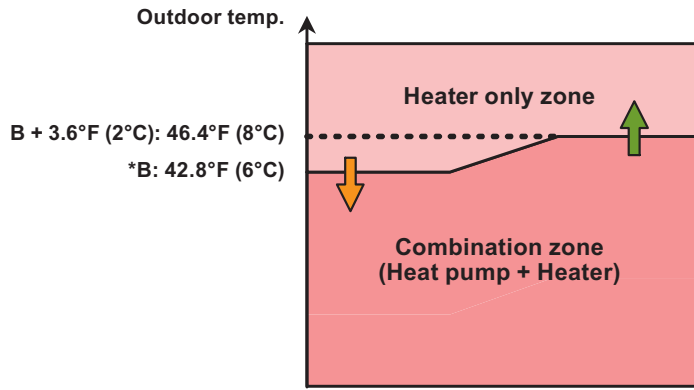

*: Adjustable by function setting 67

• Operation status

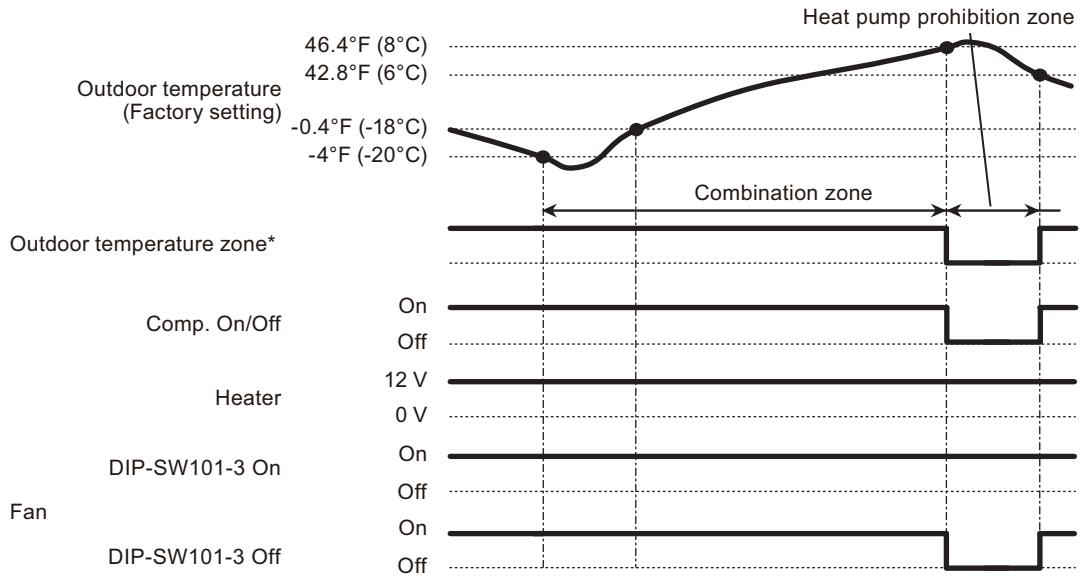

*: The outdoor temperature zone transition from one to another will stay in that zone for minimum of 30 min.

NOTE: In following operations, compressor will be on in heat pump prohibition zone.

- Other than heating
- Test run

FIELD WORKING

FIELD WORKING

● Auxiliary heat pump control by outdoor temperature 3

• External heater output

Operation			Condition
Heater on			Heater is on as shown in following diagram of heating temperature.
Heater off	DIP-SW101-3 Indoor unit fan setting for external heater	On Enabled	<ul style="list-style-type: none"> • Heater is off as shown in following diagram of heating temperature. • Other than heating mode • Error occurred • Forced thermostat off • Fan stop protection
	DIP-SW101-3 Indoor unit fan setting for external heater	Off Disabled	<ul style="list-style-type: none"> • Heater is off as shown in following diagram of heating temperature. • Other than heating mode • Error occurred • Forced thermostat off

- Temperature of heater on (Thon): Set temperature (Ts) - 0.9 °F (- 0.5 °C)
- Temperature of heater off: Set temperature (Ts) + 0.9 °F (+ 0.5 °C)

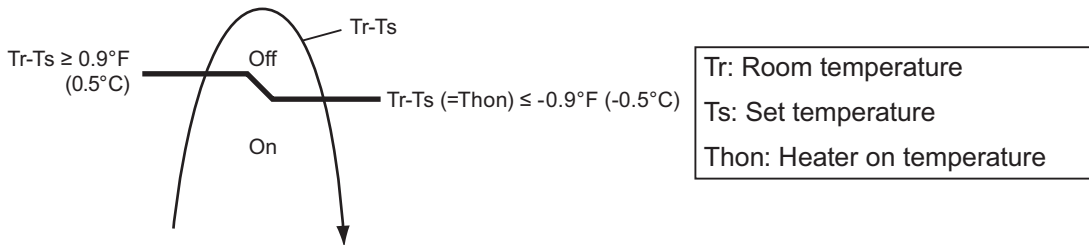

• Auxiliary heat pump On/Off

- Temperature of heater on (Thon): Adjustable by function number 62 (Operating temperature switching of heat pump).
- All control temperatures will shift by adjusting “Thon”.

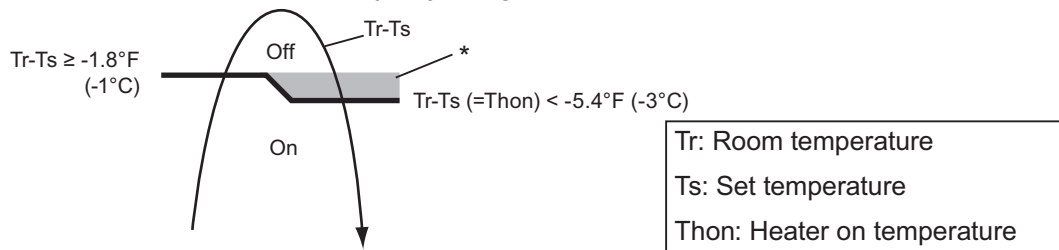

*: When room temperature stays in this zone for a specific time, auxiliary heater is turned on. For details, refer to function number 71.

• Outdoor temperature zone

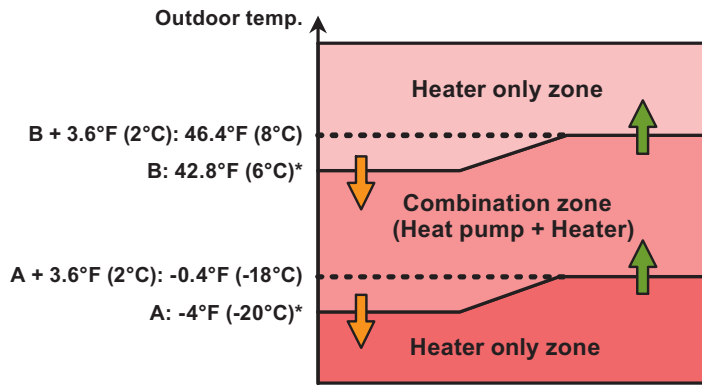

*: Adjustable by function setting 66 and 67

• Operation status

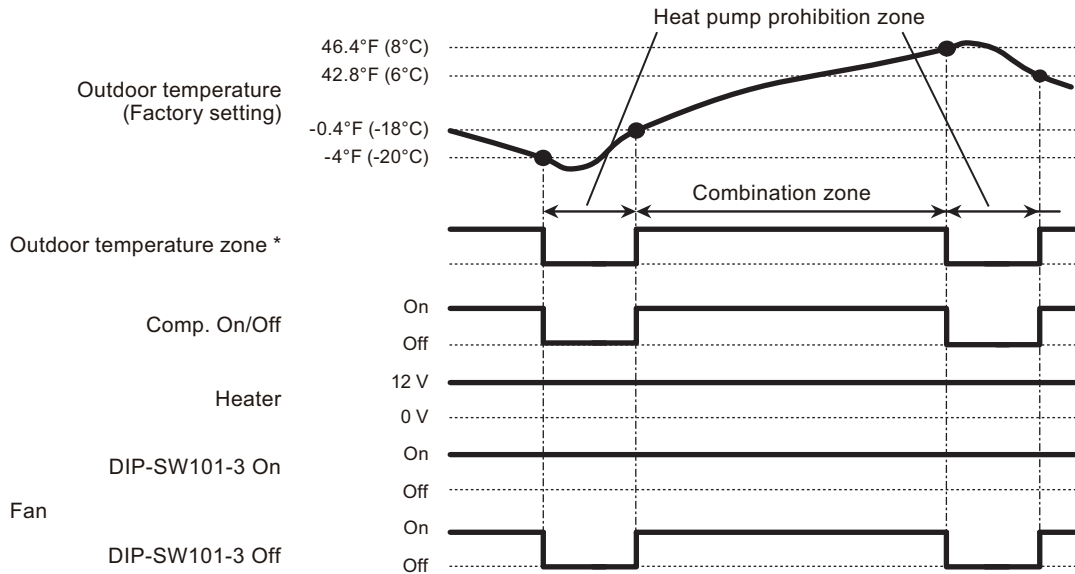

* The outdoor temperature zone transition from one to another will stay in that zone for minimum of 30 min.

NOTE: In following operations, compressor will be on in heat pump prohibition zone.

- Other than heating
- Test run

FIELD WORKING

FIELD WORKING

■ Heating thermostat on for humidifier

Situation	Indoor unit				
	Mode	Function setting	Rotary SW	External output	
		Heating thermostat on no. 60		Heating thermostat on	Indoor unit fan operation status
Example of individual connection	5	60-05	7	CN47	Not used
	6	60-06	8	Output3	
	7	60-07	9	Output2	
	8	60-08	A	Output1	

- Example of individual connection

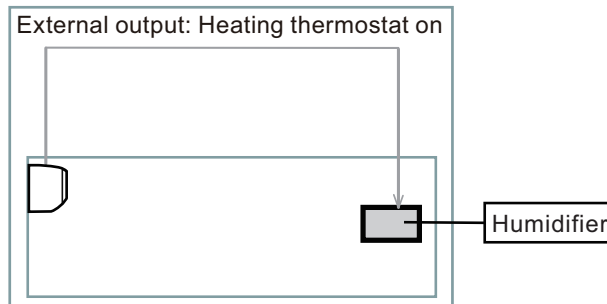

- Operation status

The heating thermostat output for CN47, Output1, Output2, and Output3 will be on when comp on or external heater on.

The heating thermostat output will be off when comp off and external heater off.

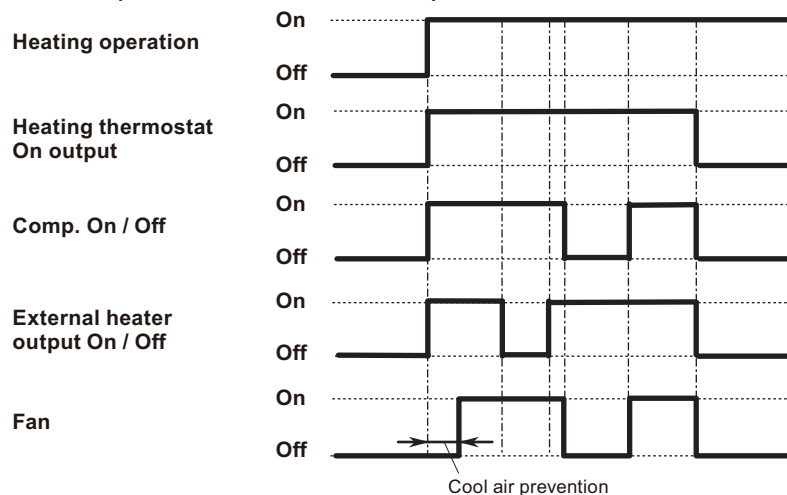

FIELD WORKING

FIELD WORKING