

Inverter Driven Heat Pump

12,000 BTU Single Zone Mid Static Duct System

Job Name _____
 Location _____
 Engineer _____
 Submitted To _____
 Submitted By _____
 Reference _____

Date _____
 Approval _____
 Construction _____
 Unit No _____
 Drawing No _____

PRODUCT FEATURES

- Up To 0.8" WC
- Quiet Operation (as low as 24 db) Separately
- Automatic Static Pressure Detection
- Heating Operation Rated Down to -5 °F
- Built in Drain Pump
- Lineset Length up to 66ft
- Controls Sold Separately
- BACnet Compatible



MODEL NUMBERS

Indoor Unit	ARUH12LUAS
Outdoor Unit	AOUH12LUAS1
System	12LUAS1R

EFFICIENCIES

SEER	21.3	
SEER 2	19.1	
EER	13.4	
EER 2	12.5	
HSPF	11.7	
HSPF 2	10.5	
COP	kW/kW	3.9
COP	Btu/hW	13.3
COP2	kW/kW	3.76
COP2	Btu/hW	12.8

OUTDOOR TEMPERATURE OPERATION RANGE

Cooling	*F(°C)	14 to 115 (-10 to 46)
Heating		-5 to 75 (-21 to 24)

CAPACITIES

Cooling	Rated	Btu/h	12000
	Min.-Max.		3,100-13,600
Heating	Rated	Btu/h	16000
	Min.-Max.		3,400-19,400

LINESET REQUIREMENTS

Connection Method	Flare	
Liquid	in (mm)	Ø1/4 (Ø6.35)
Gas		Ø3/8 (Ø9.52)
Pre-charge length	ft (m)	49 (15)
Minimum Length		16 (5)
Max. length		66 (20)
Max. height difference		49 (15)

INDOOR DIMENSIONS & WEIGHT

Net (H x W x D)	in (mm)	11-13/16 x 27-9/16 x 27-9/16 (300 x 700 x 700)
Gross (H x W x D)		15-3/4 x 36-15/16 x 34-7/16 (400 x 938 x 875)
Net Weight	lb (kg)	66 (30)
Gross Weight		82 (37)

OUTDOOR DIMENSIONS & WEIGHT

Net (H x W x D)	in (mm)	24-7/8 x 31-7/16 x 11-7/16 (632 x 799 x 290)
Gross (H x W x D)		27-1/4 x 37 x 14-3/4 (692 x 940 x 375)
Net Weight	lb (kg)	84 (38)
Gross Weight		95 (43)

Warranty Information



7 Year Compressor, 5 Year Parts out-of-the-box Warranty



10 Year Compressor, 10 Year Parts Warranty when registered within 60 days of installation in a residence



12 Year Compressor, 12 Year Parts Warranty when registered within 60 days of installation in a residence, and installed by a Fujitsu Elite contractor

ACCESSORIES

UTY-RNRUZ*	Wired Remote Controller
UTY-RSRV	Simple Remote Controller
UTY-RHRY	Simple Remote Controller
UTY-LBTUM	IR Receiver Kit with Wireless Remote Controller
UTD-LFNC	Long-life Filter
UTY-TFSXZ2	WLAN Adapter
UTY-VMSX	Modbus Converter
UTY-TTRXZ1	Thermostat Converter
UTY-TERX	External Switch Controller



This system combination is Energy Star qualified



+App available in Apple® App Store and Google® Play Store.



Due to continuous product improvements, specifications are subject to change without notice. Please log in to the Fujitsu Portal for the most up-to-date documentation <https://connect.fujitsugeneral.com>

Effective Date: 12/15/2022

Inverter Driven Heat Pump

12,000 BTU Single Zone Mid Static Duct System

FAN DATA				
Indoor Unit Airflow rate	Cooling	HIGH	CFM (m3/h)	500 (850)
		MED		400 (680)
		LOW		347 (590)
		QUIET		300 (510)
	Heating	HIGH		500 (850)
		MED		400 (680)
		LOW		347 (590)
		QUIET		300 (510)
Outdoor Unit Airflow rate	Cooling		1,171 (1,990)	
	Heating		1,089 (1,850)	
SOUND PRESSURE				
Indoor Unit	Cooling	HIGH	dB (A)	35
		MED		30
		LOW		27
		QUIET		24
	Heating	HIGH		35
		MED		30
		LOW		27
		QUIET		24
Outdoor Unit	Cooling		48	
	Heating		49	
REFRIGERANT				
Type				R410A
Charge	lb oz			2 lb 10 oz
	g			1200
Oil Type				RB68

ELECTRICAL SPECIFICATIONS				
Voltage/Frequency/Phase		208/230 V~ 60 Hz		
Available Voltage Range		187-253 V		
Current	Cooling	Rated	A	4.3
	Heating	Rated		5.5
Maximum Operating Current	Cooling			9.8
	Heating			11.3
Starting current		6.4		
MCA		13.8		
Maximum Circuit Breaker		15		
Input Power	Cooling	Rated	kW	0.96
		Min.-Max.		0.12-1.45
	Heating	Rated		1.25
Min.-Max.		0.18-1.84		
Power Factor	Cooling			97.1
	Heating			98.8
OTHER				
Moisture Removal		pints/h (L/h)	1.5 (0.7)	
Energy Star			Yes	
Drain hose	Material	PVC		
	Tip diameter	in (mm)	Ø13/16 (20.7) (I.D.), Ø1-1/16 (26.6) (O.D.)	
Operation Range	Cooling	°F (°C)	64 to 90 (18 to 32)	
	Heating	%RH	80 or less	
Static pressure range	Cooling	°F (°C)	60 to 86 (16 to 30)	
	Heating	inWG (Pa)	0.12 to 0.80 (30 to 200)	

DIMENSIONS:

Units: In. (mm)

Indoor Unit:

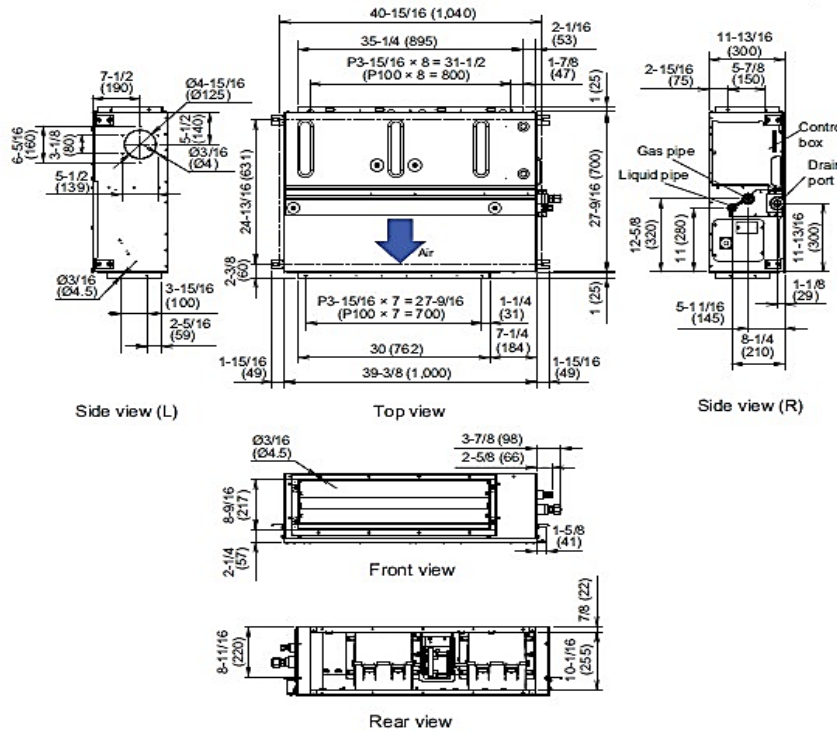

DIMENSIONS

Units: In. (mm)

Outdoor Unit

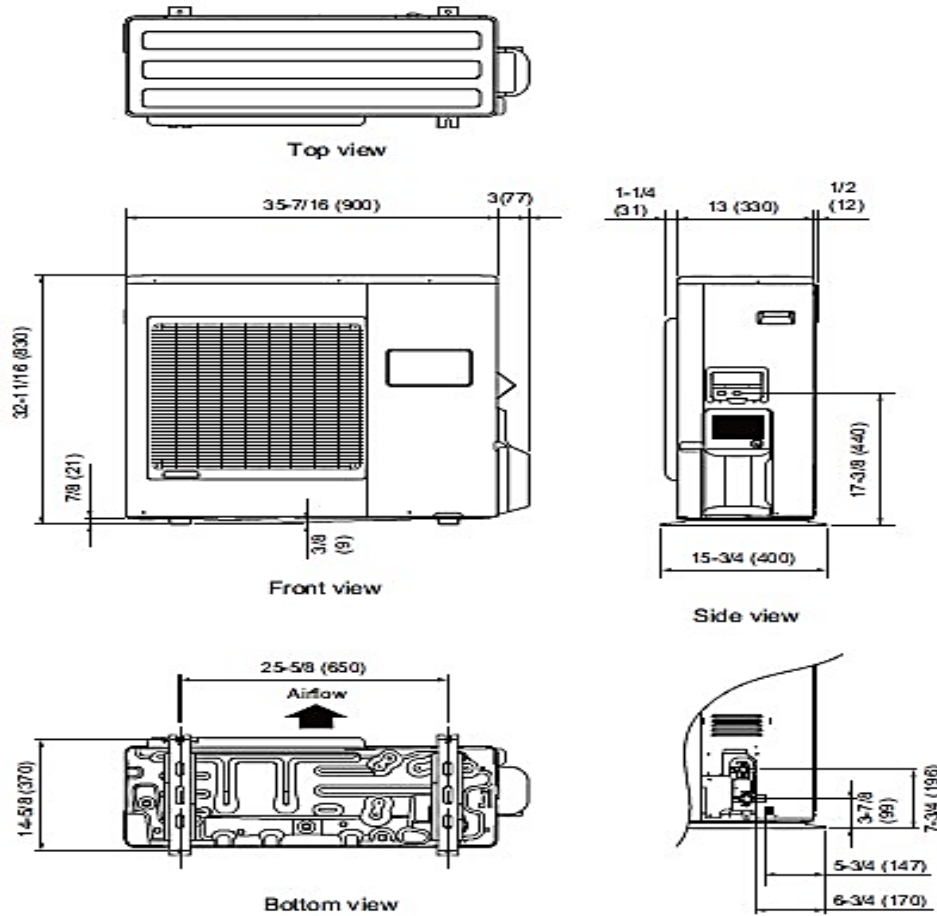

The Fujitsu logo is a worldwide trademark of Fujitsu General Limited. The Airstage logo and name is a worldwide trademark of Fujitsu General Limited and is a registered trademark in Japan, the USA and other countries or areas. Copyright 2022 Fujitsu General America, Inc. Fujitsu's products are subject to continuous improvements. Fujitsu reserves the right to modify product design, specifications and information in this brochure without notice and without incurring any obligations.

Note: Specifications are based on the following conditions:
 Cooling: Indoor temperature of 80°F (26.7°C) DB/67°F (19.4°C) WB, and outdoor temperature of 95°F (35°C) DB/75°F (23.9°C) WB. Heating: Indoor temperature of 70°F (21.1°C) DB/60°F (15.6°C) WB, and outdoor temperature of 47°F (8.3°C) DB/43°F (6.1°C) WB. Pipe length: 25ft. (7.5m), Height difference: 0ft. (0m) (Outdoor unit - indoor unit).