

Technical Data Manual

Model Nos. and pricing: see Price List



For Natural Gas and Liquid Propane Gas
Gas-fired floor-mounted condensing DHW combi-boiler
12 to 125 MBH (3.5 to 37 kW)



VITODENS® 222-F



Product may not be exactly as shown

Vitodens 222-F B2TB Series 19, 35, 68, 125

Gas-fired floor-mounted condensing DHW combi-boiler with
modulating Matrix cylinder burner and DHW stainless steel tank.
For room air independent operation or room air dependent operation.



Vitodens 222-F

The Vitodens 222-F storage combi-boiler combines the benefits of the Vitodens 222-F with the high DHW convenience of a separate DHW tank. With the Matrix gas burner and the stainless steel Inox-Radial heat exchanger, the Vitodens 222-F offers top technology for many years of energy efficiency and high heating and DHW convenience. The Lambda Pro Control combustion controller and the 3-speed high efficiency circulation pump, ensure permanently high efficiency, reliable operation and low power consumption.

The integral stainless steel 26.5 USG (100 L) primary storage tank offers the same DHW convenience as a separate DHW cylinder approximately twice the size.

Recommended applications

- Installation in single or semi-detached homes and apartments.
- New build (e.g. pre-fabricated houses and housing association projects): installation in utility rooms and attics.
- Modernisation: Replacement of system boilers, floorstanding atmospheric gas boilers and oil/gas boilers with DHW cylinders below.

Delivered condition

Gas condensing boiler with Inox-Radial heat exchanger, modulating Matrix gas burner for natural gas and LPG cylinder, expansion vessel, 3-speed high efficiency circulation pump and integral stainless steel DHW primary storage tank. Fully piped plumbed and wired.

White epoxy-coated casing. Preset for operation with natural gas. The conversion to LPG is made at the gas valve (a conversion kit is not required) and control unit.

Innovative Storage Tank Loading System (STLS)

Advanced Storage Tank Loading System technology in the Vitodens 222-F ensures a reliable and efficient DHW supply equivalent to that of a larger tank. The STLS utilizes an external plate heat exchanger and DHW loading pump for extremely fast heat-up capable of delivering a 10 minute peak flow of 60 gallons or continuous DHW draw of 3.3 GPM*.

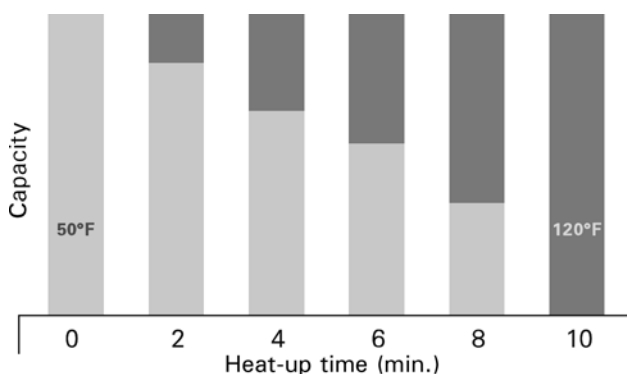

Benefits at a glance

- Viessmann made SA240 / S43932 stainless steel Inox-Radial heat exchanger constructed to CSA B51 and ASME Section IV
- Viessmann made stainless steel Matrix cylinder burner with Lambda Pro combustion management system for continuous efficiency and low emissions
- 2 models with input ranges from 12 to 125 MBH
- Viessmann made AISI444 / S44400 stainless steel DHW storage tank 26.5 USG (100 L)
- Zero side clearance requirement
- Pre-installed pressure / temperature relief valves
- Fully enclosed heating expansion tank and circulation pump
- Exceeds Energy Star® Efficiency Requirements
- Built-in 3-speed DHW / space heating pump with diverter valve
- Suitable for altitude levels up to 10,000 ft. (3,050 m)
- Wide modulation ratio up to 6.5:1
- Multiple venting options with vent length up to 180 ft. (55 m)
- 10-minute peak flow of 60 USG (227 L)*
- Continuous DHW draw of 3.3 GPM*
 - * Based on a temperature rise of 70°F (39°C) 50°F to 120°F (10°C to 49°C) (model B2TB 35, 125 only)
- Fast heat-up with Storage Tank Loading System
- Innovative DHW Storage Tank Loading System comprised of plate heat exchanger, DHW loading pump and storage tank
- Zone circuit capabilities provide 3 input connections that allow easy integration of third party components such as thermostats, SIM controls, Multizone controllers, and other smart or on/off control technologies
- The setup of these new capabilities can be done quickly with the start-up wizard that prompts the installer for the relevant information necessary to setup the system without having to go into complex levels of coding parameters
- The unique capability of the new zone circuit control allows the installer to combining temperature setpoint operation and outdoor reset capability. This means that one or all of the 3 zone circuits control can operate on a set temperature, or vary based on the outdoor reset curve that is selected in the start-up wizard
- Certified to CSA Low Lead Content Certification Program; including US Safe Drinking Water Act, NSF/ANSI 372 as well as other applicable US State requirements

Cross-Section

Vitodens 222-F, series B2TB 19, 35, 68, 125

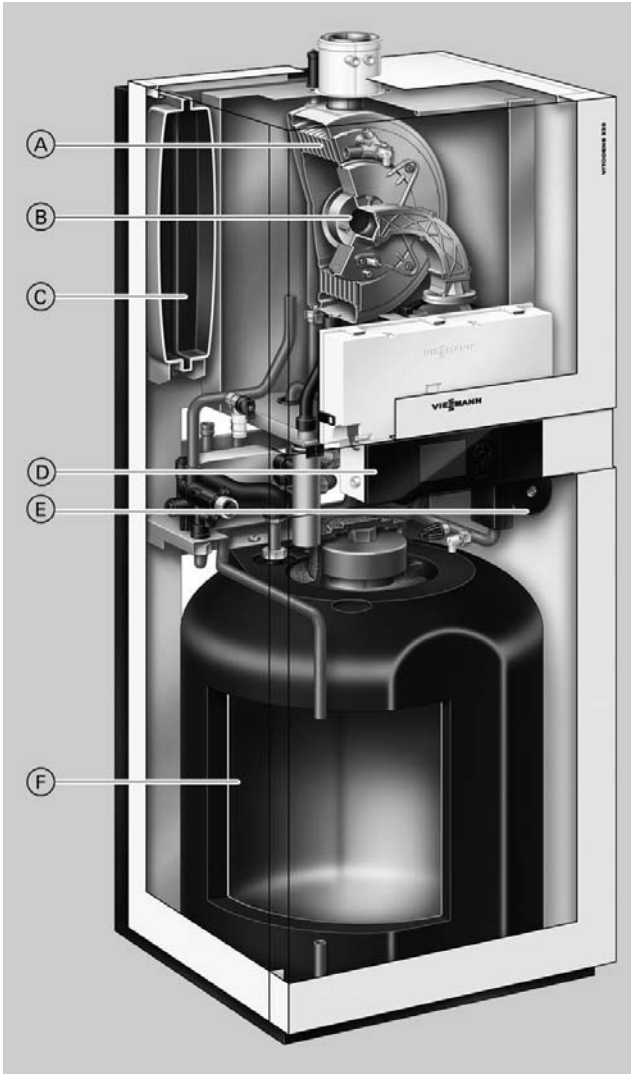

Product may not be exactly as shown

- (A) Stainless steel Inox-Radial heat exchanger for high operational reliability, a long service life and high heating output in the smallest space
- (B) Modulating MatriX cylinder gas burner for extremely clean combustion
- (C) Integral diaphragm expansion tank
- (D) Digital boiler control unit
- (E) Integral, 3-speed high efficiency circulation pump
- (F) Stainless steel DHW primary storage tank.

The flue gas temperature is only approximately 9°F -27°F (5°C-15°C) above boiler return temperature (see chart below).

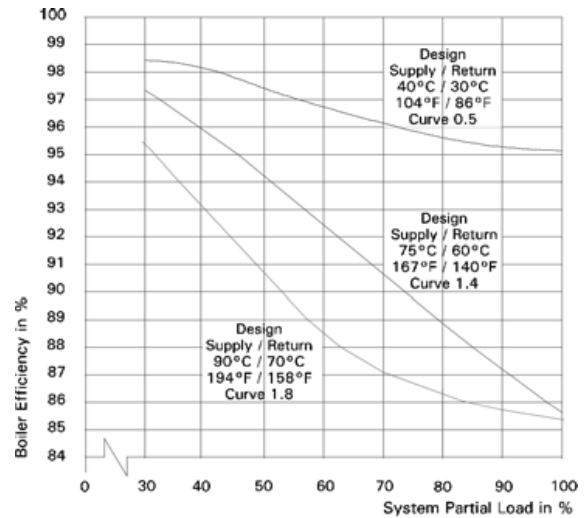

Vitodens 222-F boiler efficiency dependent on system heating water return temperatures and load conditions

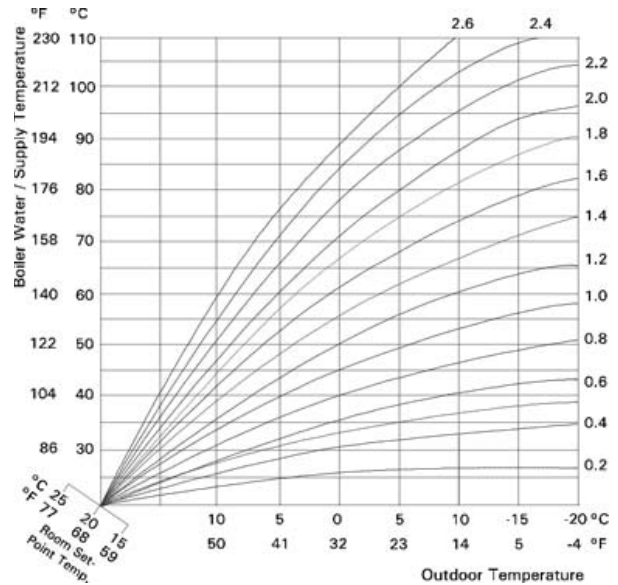

Technical Data

Boiler Model No. 222-F B2TB		19, 68	35, 125
CSA input Natural Gas (NG)	MBH (kW)	12-68 (3.5-20)	19-125 (5.5-37)
CSA input Liquid Propane Gas (LPG)	MBH (kW)	12-68 (3.5-20)	31-125 (9-37)
CSA output/DOE *1 heating capacity NG	MBH (kW)	11-64 (3.2-19)	18-117 (5-34)
CSA output/DOE *1 heating capacity LPG	MBH (kW)	11-64 (3.2-19)	29.5-117 (8.6-34)
Net AHRI rating *2	MBH (kW)	55 (16)	102 (30)
Heat exchanger surface area	ft. ² m ²	12.96 1.2	12.96 1.2
Min. gas supply pressure			
Natural gas	"w.c.	4	4
Liquid propane gas	"w.c.	10	10
Max. gas supply pressure *3			
Natural gas	"w.c.	14	14
Liquid propane gas	"w.c.	14	14
A.F.U.E.	%	95	95
Weight (including installation fittings)	lbs (kg)	302 (137)	302 (137)
Boiler water content	USG (L)	1.02 (3.88)	1.02 (3.88)
Boiler max. flow rate *4	GPM (L/h)	6.2 (1400)	6.2 (1400)
Expansion tank *5 (for heating system side)			
Precharge pressure	psig	12	12
Capacity	USG (L)	3.2 (12)	3.2 (12)
Max. operating pressure at 210°F (99°C)	psig bar	45 3	45 3
Boiler water temperature			
- Adjustable high limit (AHL) range space heating (steady state)	°F (°C)	68 to 180 (20 to 82)	68 to 180 (20 to 82)
- Fixed high limit (FHL)	°F (°C)	210 (99)	210 (99)
Boiler connections			
Boiler heating supply and return	NPTM"	3/4"	3/4"
Pressure relief valve	NPTF"	3/4"	3/4"
Drain valve	(male thread)	3/4"	3/4"
Boiler supply/return for indirect-fired DHW storage tank (field supplied)	NPT"	3/4"	3/4"
Gas valve connection	NPTF"	3/4"	3/4"

*1 Output based on 140°F (60°C), 120°F (49°C) system supply/return temperature.

*2 Net AHRI rating based on piping and pick-up allowance of 1.15.

*3 If the gas supply pressure exceeds the maximum gas supply pressure value, a separate gas pressure regulator must be installed upstream of the heating system.

*4 See "Waterside Flow" starting on page 8 in this manual.

*5 Determine the required size of the expansion tank to be installed in the heating system. If the integral expansion tank is insufficient, install a suitably sized expansion tank on site.

Technical Data

Boiler Model No. 222-F B2TB		19, 68	35, 125
Dimensions			
Overall depth	inches (mm)	23½ (595)	23½ (595)
Overall width	inches (mm)	23⅝ (600)	23⅝ (600)
Overall height *12	inches (mm)	64 (1625)	64 (1625)
Flue gas *6			
Temperature (at boiler return temperature of 86°F (30°C))			
- at rated full load	°F (°C)	113 (45)	113 (45)
- at rated partial load	°F (°C)	95 (35)	95 (35)
Temperature (at boiler return temperature of 140°F (60°C))			
	°F (°C)	154 (68)	154 (68)
Average condensate flow rate *7			
with natural gas and T _S /T _R = 122/86°F (50/30°C)			
	USG/h (L/h)	2.6-3.4 (10 - 12)	4-4.5 (15 - 17)
Condensate connection *8			
	hose nozzle Ø in.	¾-1	¾-1
Boiler flue gas connection *9			
	Ø in. (mm)	2⅜ (60)	2⅜ (60)
Combustion air supply connection (coaxial)			
	outer Ø in. (mm)	4 (100)	4 (100)
Sound Rating			
- at maximum input	dB	41	51
- at minimum input	dB	35	36
DHW storage tank			
DHW storage tank capacity	USG (L)	26.5 (100)	26.5 (100)
Temperature and pressure relief valve (factory installed)	psig/temp	150 / 210°F (99°C)	150 / 210°F (99°C)
Max. allowable operating pressure (DHW)	psig	150	150
Storage tank test pressure	psig	300	300
Continuous DHW output	MBH (kW)	61 (17.8)	114 (33.4)
Continuous DHW output draw rate *10	GPM (L/min.)	1.8 (6.6)	3.3 (12.3)
Max. DHW draw rate (over 10 min. period) *10	USG (L)	44 (166)	60 (227)
Standby losses *11			
	BTU/24h	4435	4435
	BTU/h	184	184
	° F/h	0.8	0.8

*6 Measured flue gas temperature with a combustion air temperature of 68°F (20°C).

*7 Based on typical boiler cycles, including partial load conditions.

*8 Requires 1 inch (25 mm) tubing. See the Installation Instructions of the Vitodens 222-F, B2TB for details.

*9 For side wall vent installations (coaxial system):

Do not exceed max. equivalent length specified in the Installation Instructions of the Vitodens 222-F, B2TB Venting System.

Do not attempt to common-vent Vitodens 222-F, B2TB with any other appliance.

Side wall coaxial vent installation must include Viessmann protective screen!

For details refer to the Installation Instructions for the Vitodens 222-F, B2TB Venting System.

*10 Based on a temperature rise of 70°F (39 K), 50°F to 120°F (10°C to 49°C).

*11 Measured values are based on room temperature of 68°F (20°C) and a domestic hot water temperature of 149°F (65°C).

*12 Add 1⅝ in. (40 mm) when using the optional accessory seismic bracket kit.

For information regarding other Viessmann System Technology componentry, please reference documentation of respective product.

Note: For high altitude installation at 10,000 ft. (3050 m) the input for 222-F, B2TB 19, 35, 68, 125 will have an altitude de-rating of 21%.

Models 222-F, B2TB 19, 35, 68, 125

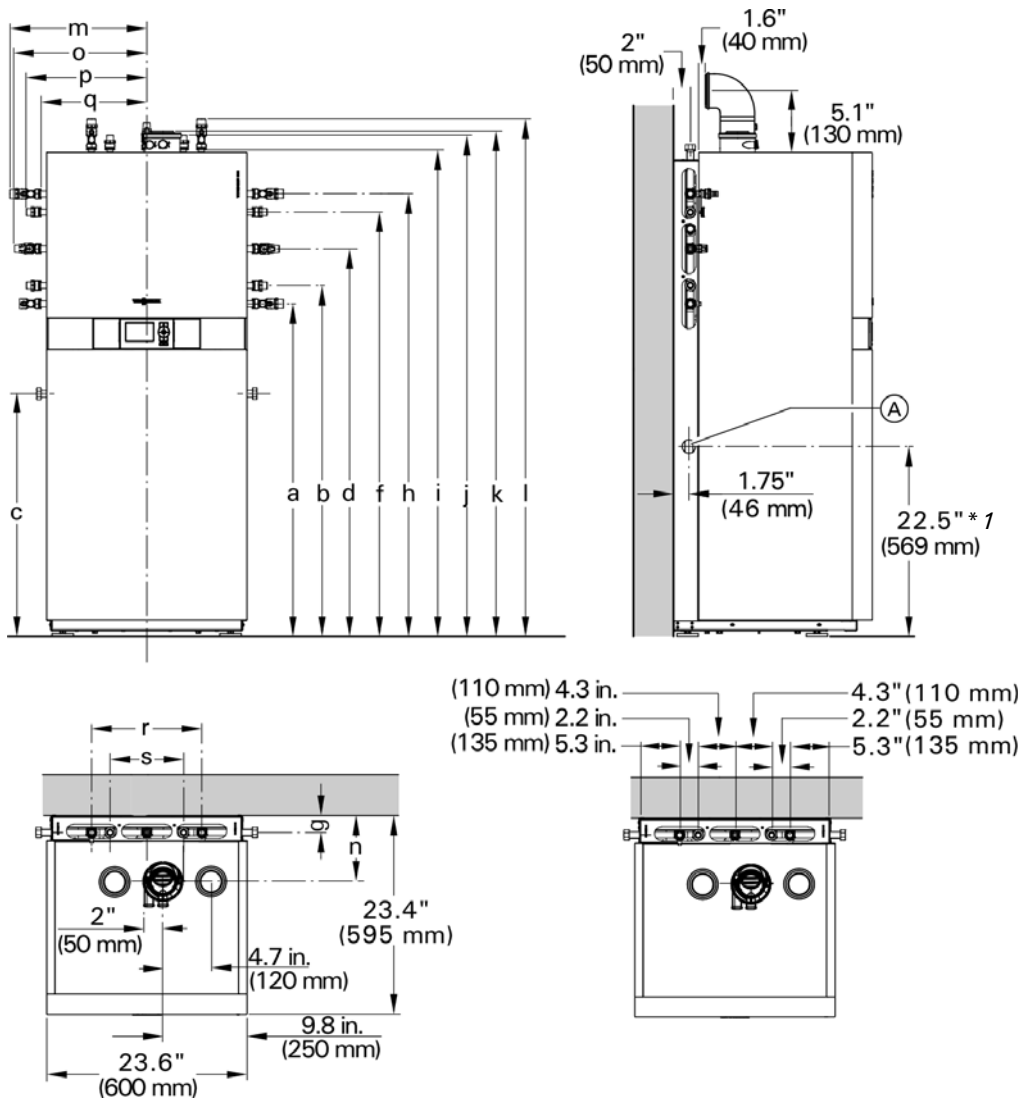

Note: The dimensional drawing shows example fittings for upward connection and connection to the left/right, for installation on finished walls. Order the connection sets separately as accessories. For the dimensions of the individual connection sets, see the design information.

Model B2TB 19, 35, 68, 125			Model B2TB 19, 35, 68, 125		
a * 1	in. (mm)	46.1 (1172)	k * 1	in. (mm)	65.6 (1665)
b * 1	in. (mm)	48.3 (1227)	l * 1	in. (mm)	68.0 (1726)
c * 1	in. (mm)	28 (710) approx.	m	in. (mm)	16.1 (410)
d * 1	in. (mm)	52.6 (1337)	n	in. (mm)	8.8 (224)
f * 1	in. (mm)	57.0 (1447)	o	in. (mm)	15.3 (389)
g	in. (mm)	2.0 (50)	p	in. (mm)	14.2 (361)
h * 1	in. (mm)	59.1 (1502)	q	in. (mm)	12.6 (320)
i * 1	in. (mm)	64.2 (1630)	r	in. (mm)	13.0 (330)
j * 1	in. (mm)	65.6 (1666)	s	in. (mm)	8.7 (220)

Note: All height dimensions of the boiler have a tolerance of +.6 in. (+ 15 mm) due to the factory installed adjustable feet

* 1 Add 1 5/8 in. (40 mm) when using the optional accessory seismic bracket kit.

Note: All height dimensions of the boiler have a tolerance of +.5 in. (+ 13 mm) due to the seismic bracket adjustable feet.

Recommended Minimum Service Clearances

Recommended minimum service clearances

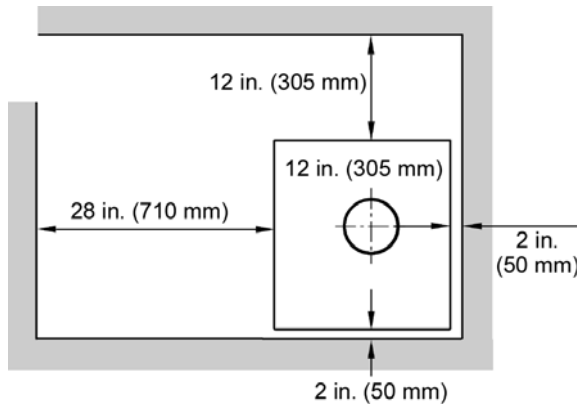

Note: The Vitodens 222-F, B2TB boiler has passed the zero inches vent clearance to combustibles testing requirements dictated by the boiler Harmonized Standard ANSI Z21.13, CSA 4.9 (latest edition) and therefore is listed for zero clearance to combustibles when vented with a single-wall UL/ULC certified special venting system. The zero inches vent clearance to combustibles for the Vitodens boiler supercedes the clearance to combustibles listing that appears on the special venting system label.

The back or side clearance shall be increased if piping installation is required.



See the Vitodens 222-F B2TB Venting System Installation Instructions for details.

Minimum clearances to combustibles

Boiler model B2TB	19, 68	35, 125
Top	0	0
Sides (left and right)	0	0
Vent pipe	0	0
Front (alcove or closet)	0	0
Rear	0	0
Floor	combustible	combustible

Waterside Flow (primary circuit)

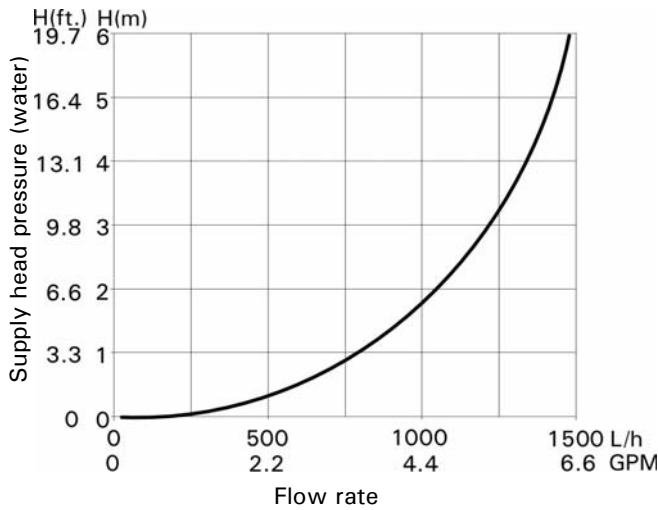

Pressure drop (primary circuit) for Vitodens 222-F, B2TB 19, 35, 68, 125

The Vitodens 222-F, B2TB is designed for closed loop, forced circulation hot water heating systems only. Use standard friction loss method for pipe sizing. Observe boiler maximum and minimum flow rate limitations. If system flow rate exceeds boiler maximum flow rate (as stated below), falls below the minimum flow rate or if system flow rate is unknown, Viessmann strongly recommends the installation of a low-loss header. An alternative method may be used, such as primary secondary piping using closely spaced tees.

A low-loss header offers additional benefits not provided by a pair of closely spaced tees. Viessmann therefore strongly recommends and prefers the use of a low-loss header over closely spaced tees. See pages 19 and 20 for low-loss header information. Once the low-loss header is connected, the built-in low-loss header logic of the Vitodens 222-F boiler ensures the required Δt across the system through the sensory communication between the low-loss header and the boiler.

Boiler maximum flow rate 6.2 GPM (1400 L/h)

Model B2TB 19, 68		1 boiler
Output (NG/LPG)		
	MBH	64
Δt for NG/LPG		
20°F (11°C) rise	GPM (L/h)	6.4 (1453)
25°F (14°C) rise	GPM (L/h)	5.1 (1163)
30°F (17°C) rise	GPM (L/h)	4.3 (969)
35°F (19.5°C) rise	GPM (L/h)	3.7 (830)
40°F (22°C) rise	GPM (L/h)	3.2 (727)

Boiler maximum flow rate 6.2 GPM (1400 L/h)

Model B2TB 35, 125		1 boiler
Output (NG/LPG)		
	MBH	117
Δt for NG/LPG		
20°F (11°C) rise	GPM (L/h)	11.7 (2657)
25°F (14°C) rise	GPM (L/h)	9.4 (2126)
30°F (17°C) rise	GPM (L/h)	7.8 (1771)
35°F (19.5°C) rise	GPM (L/h)	6.7 (1518)
40°F (22°C) rise	GPM (L/h)	5.9 (1328)

Heating Circuit

Vitodens 222F B2TB 19-125 are equipped with a boiler/ system pump. The system pump flow must be selected on Δt . If the system flow exceeds the boiler's maximum flow rate , a low-loss header is strongly recommended.

IMPORTANT

Pump selection must be based on accurate system flow and pressure drop calculations (includes DHW sizing).

Low-Loss Header Application

Sizing of Low-Loss Header in a Residential Single-Boiler Application

Boiler Model	No. of Boilers	Boiler Max. Flow Rate GPM (L/h)	Typical System Flow Rates							Viessmann Low-loss Temp. Sensor Required* 2
			Δt * 1	°F (°C)	20 (11.0)	25 (13.9)	30 (16.8)	35 (16.1)	40 (13.4)	
B2TB 19, 68	1	6.2 (1400)	System Flow Rate LLH Required LLH Model	GPM (L/h)	6.4 (1453) Yes 80/60	5.1 (1163) Optional 80/60	4.3 (969) Optional 80/60	3.7 (830) Optional 80/60	3.2 (727) Optional 80/60	included
B2TB 35, 125	1	6.2 (1400)	System Flow Rate LLH Required LLH Model	GPM (L/h)	11.7 (2657) Yes 80/60	9.4 (2126) Yes 80/60	7.8 (1771.6) Yes 80/60	6.7 (1518) Yes 80/60	5.9 (1328) Optional 80/60	included

* 1 For system $\Delta t < 20^\circ\text{F}$ (11°C) use low-loss header sizes for $\Delta t 20^\circ\text{F}$ (11°C).

* 2 Low-Loss temperature sensor - is included with the boiler for use in single-boiler applications.

Note: The Vitodens 222-F comes equipped with a factory preset integrated boiler pump.

Heating Circuit Pumps

Grundfos UPS15-78 three speed heating circuit/DHW circuit pump for Vitodens 222-F, B2TB boilers (in the factory setting, the pump speed is preset to 'speed three')

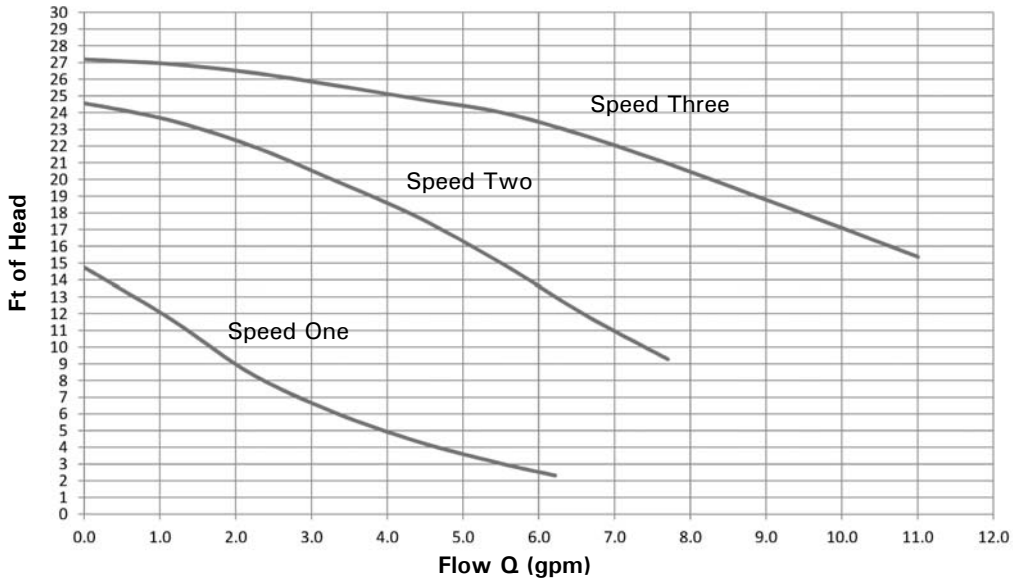

Performance chart courtesy of Grundfos

Pump Model	Grundfos UPS15-78	
Rated voltage	VAC	115
Rated current	A max.	1.15
	A min.	0.8
Capacitor	μ F	8
Power consumption	W max.	130
	W min.	80

Grundfos UPS15-78 residual head pressure

Residual head of built-in three speed pump used with Vitodens 222-F, B2TB

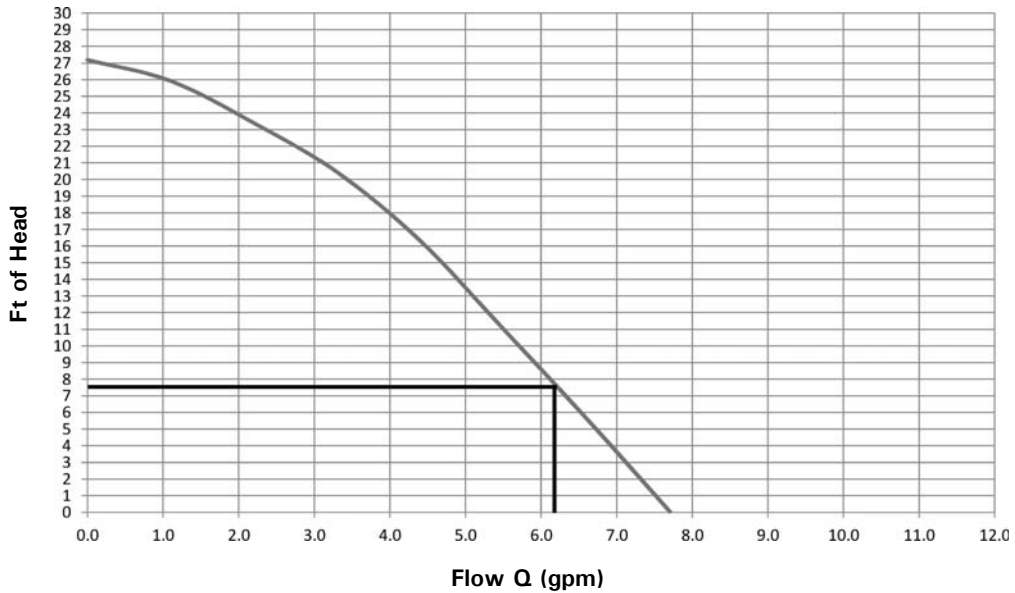

Domestic Hot Water Production

The Vitodens 222-F storage combi-boiler combines the benefits of the Vitodens 200-W with high DHW convenience of a separate integral stainless steel DHW storage tank.

The Vitodens 222-F uses an integrated 26.5 USG (100 L) DHW storage tank and an integrated DHW production pump.

IMPORTANT

A diaphragm expansion tank is integrated into the Vitodens 222-F, with a capacity of 3.2 USG (12 L) and a pre-charge pressure of 12 psig.

Determine the required size of the expansion tank to be installed in the heating system. If the integral expansion tank is insufficient, install a suitably sized expansion tank on site.

Domestic Hot Water Recirculation

DHW recirculation lines increase the level of comfort and convenience of the domestic hot water supply and reduce water consumption.

These advantages directly derive from the immediate availability of domestic hot water at all draw points.

Poor insulation of the DHW recirculation line, however, can result in considerable heat loss. Viessmann therefore recommends that effective insulation be provided and used for DHW recirculation lines of 23 ft. (7 m) in length or longer.

On-Board Vitotronic 200, HO1B Control

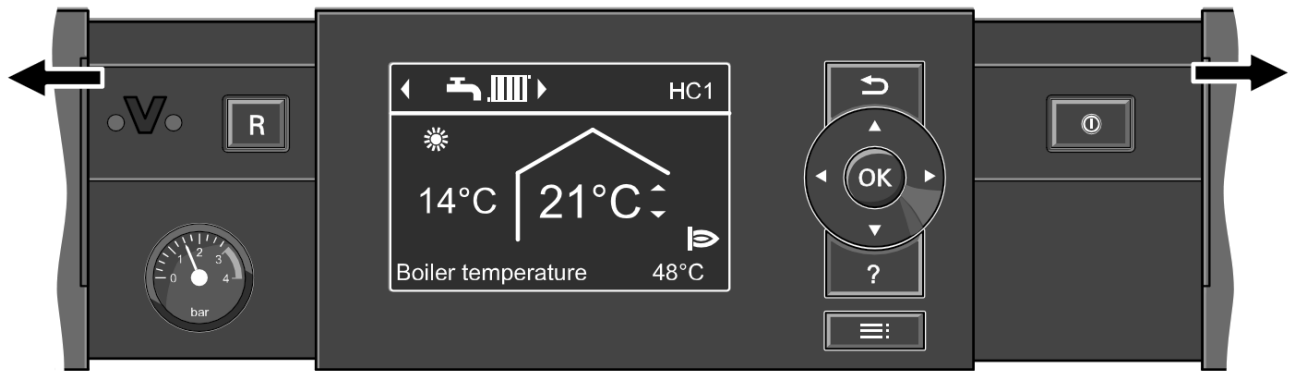

Modular structure

The control unit is integrated into the boiler. The control unit comprises a standard unit, electronics modules and a programming unit.

Standard unit:

- ON/OFF switch
- Optolink laptop interface
- Operating and fault indicators
- Reset button
- Fuses

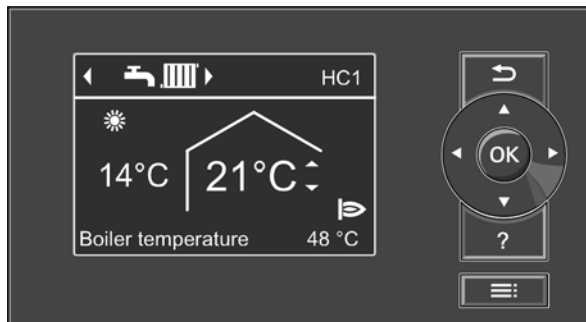

Heating circuit interface

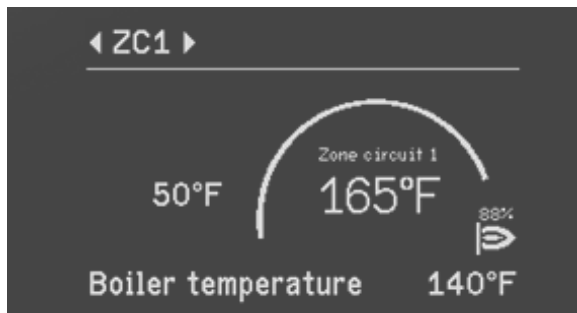

Zone control interface

Programming unit:

- Easy operation through:
 - Plain text display with graphic ability
 - Large font and black & white depiction for good contrast
 - Context-sensitive help text
 - Removable programming unit; can be mounted on the wall with separate accessory
- With digital time switch
- Control keys for:
 - Navigation
 - Confirmation
 - Help and additional information
 - Menu
- Setting the:
 - Room temperature
 - Reduced room temperature
 - DHW temperature
 - Heating program
 - Time programs for central heating, DHW heating and DHW recirculation
 - Economy mode
 - Party mode
 - Holiday program
 - Heating curves
 - Codes
 - Actuator tests
 - Test mode
- Displaying the:
 - Boiler water temperature
 - DHW temperature
 - Operating details
 - Diagnostic details
 - Fault messages

Design and Function

Functions

- Weather-compensated control of the boiler water and/or supply temperature
- Control of one heating circuit without mixer and two heating circuits with mixer (with accessory mixing valve extension modules)
- Demand-dependent heating circuit pump and burner off control
- Controls up to three zone circuits without mixing valves
- Adjustment of a variable heating limit
- Anti-seizing pump protection
- Integral diagnostic system
- Maintenance display
- DHW temperature control with priority
- Auxiliary function for DHW heating (short-term heating to a higher temperature)
- 0-10V External signal input

Control Characteristics

PI characteristics with modulating output.

Time Switch

Digital time switch.

- Individual and 7-day program
- Automatic daylight savings time changeover
- Automatic function for DHW heating and DHW recirculation pump
- Time, day and standard switching times for space heating, DHW heating and the DHW recirculation pump are factory-set
- Switching times are individually programmable, i.e. up to four switching periods per day
Shortest switching interval: 10 minutes
Power backup: 14 days.

Setting the Operating Programs

The heating system frost protection (see frost protection function) applies to all heating programs. You can select the following heating programs with the program keys:

- Heating and DHW
 - Zone circuits
 - DHW only
 - Standby mode
 - Zone circuits (dry contact thermostat)
- External heating program changeover.

Frost protection

- The frost protection function will be started when the outside temperature drops below approx. 34°F (1°C). With the frost protection function, the heating circuit pump will be switched ON and the boiler water is maintained at a lower temperature of approx. 68°F (20°C).
The DHW tank will be heated to approx. 68°F (20°C).
- The frost protection function will be stopped when the outside temperature rises above approx. 37°F (3°C) (default settings).

Summer Operation

Heating program “”

The burner is only activated upon a call for domestic hot water from the DHW storage tank (controlled by DHW tank temperature sensor).

Design and Functions *(continued)*

Technical Data

Rated supply voltage:	120 VAC
Rated frequency:	60 Hz
Rated current:	12 A
Max. ambient temp. - at operation:	32 to 104°F (0 to 40°C) Installation in living spaces or boiler rooms (standard ambient conditions)
- when storing or transporting:	-4 to +158°F (-20 to +70°C)
Max. operating temp. setting (space heating):	
Models B2TB 19 to 125	180°F (82°C)
DHW production:	
Models B2TB 19 to 125	180°F (82°C)
Setting fixed high limit: (not adjustable)	210°F (99°C)
Adjustment range of DHW tank set-point temperature:	50 to 154°F (10 to 68°C)
Heating curve settings	
- Heating curve slope:	0.2 to 3.5
- Heating curve shift:	-12 to +33°C -13 to 40 K

Heating Curve Adjustment (slope and shift)

The control unit regulates the boiler water temperature (= supply temperature of heating circuit without mixing valve) and the supply temperature of the heating circuit with mixing valve (in conjunction with the accessory kit for a heating circuit with mixing valve) according to the outdoor temperature. The boiler water temperature is automatically raised by 0 to 72 F / 0 to 40 K higher than the currently required set supply temperature (in the factory default setting the differential temperature is 14.4 F / 8 K). See Service Instructions for coding address "9F" in coding level 2.

The supply temperature that is required to achieve a given room temperature depends on the heating system and the thermal insulation of the building that is being heated.

The adjustment of the two heating curves is used to match the boiler water temperature and the supply temperature to these conditions. The boiler water temperature is limited upwards by the fixed high limit and the temperature set for the electronic high limit. The supply temperature cannot rise above the boiler water temperature.

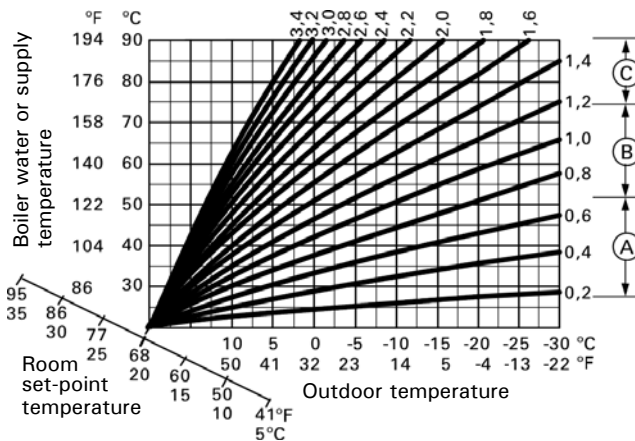

Legend

- (A) Low temperature heating system, e.g. radiant floor heating
- (B) Medium temperature heating system, e.g. cast iron radiation, staple-up radiant floor heating
- (C) High temperature heating system, e.g. fintube radiation, fan coils

Sensors *(supplied)*

Boiler Temperature Sensor

The boiler temperature sensor is connected at the control unit for weather-responsive operation and is built into the boiler.

Specification sensor type: Viessmann NTC 10K ohms at 77°F (25°C)

Max. ambient temp.
 - at operation: 32 to 266°F (0 to 130°C)
 - when storing or transporting: -4 to +158°F (-20 to +70°C)

DHW Tank Temperature Sensor

- integrated DHW temperature sensor

Immersion Temperature Sensor

To capture the low loss temperature (if the LLH is used)

Specification
 Lead length fully wired: 12 ft. (3.75 m),
 Permissible ambient temp.
 - during operation: 32 to 194°F (0 to 90°C)
 - when storing or transporting: - 4 to +158°F (-20 to +70°C)

Outdoor Temperature Sensor

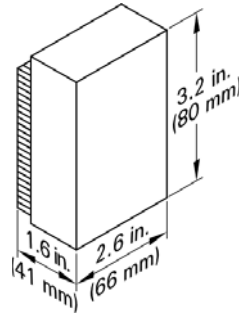

Sensor location:
 - North or northwest wall of building
 - 6.6 to 8.2 ft. (2 to 2.5 m) above ground or in case of a multi-storey building approximately halfway up the second floor

Electrical connection:
 - 2-wire cable, max. cable length 115 ft. (35 m) with a wire size of min. AWG 16 copper
 - Cable to the outdoor sensor must not be laid near line voltage wiring (120/240V)

Max. ambient temperature during transport, storage and operation: -40 to 194°F (-40 to 90°C)

Optional Accessories

Supply Temperature Sensor

(strap-on sensor, included with mixing valve actuator accessory kit),

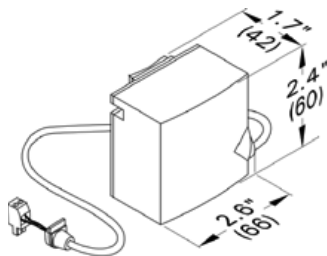

- when storing or transporting: -4 to +158°F (-20 to +70°C)

Installed with a strapping band.
 Cable length 19.7 ft. (6 m), ready to plug in.
 Max. ambient temp.

- at operation: 32 to 212°F (0 to 100°C)
 - when storing or transporting: -4 to +149°F (-20 to +70°C)

KM BUS Expansion Module

To connect 2 to 9 devices (mixing valve actuator, Vitotrol, input module, etc.) to the single KM BUS connection of the boiler.

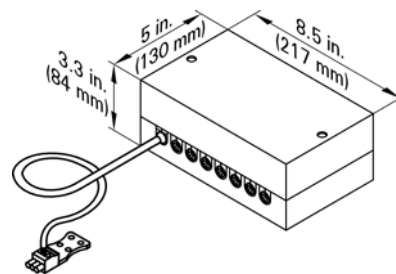

Specification
 Lead length 10 ft. (3.0 m), fully wired

Permissible ambient temp.
 - during operation 32 to 104°F (0 to 40°C)

- during storage and transport: - 4 to +149°F (-20 to +65°C)

Optional Accessories *(continued)*

Room Temperature Sensor,

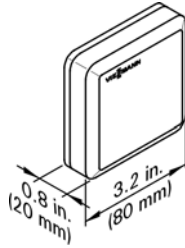

Separate room temperature sensor as supplement to the Vitotrol 200A and 300A; to be used if the Vitotrol 200A or 300A cannot be installed inside the main living room or in a suitable position where the unit can capture and adjust the temperature.

Installation in the main living room on an internal wall opposite radiators. Never install inside shelf units, recesses, immediately by a door or heat source (e.g. direct sunlight, fireplace, TV set, etc.).

Connect the room temperature sensor to the Vitotrol 200A or 300A.

Electrical connection:

- 2-wire cable with a wire size of min. AWG 18 copper
- The cable length between the control unit, remote control unit and room temperature sensor must not exceed 98 ft. (30 m)

Max. ambient temp.

- at operation: 32 to 104°F (0 to 40°C)
- when storing or transporting: -4 to + 149°F (-20 to + 65°C)

Mixing Valve Extension Module

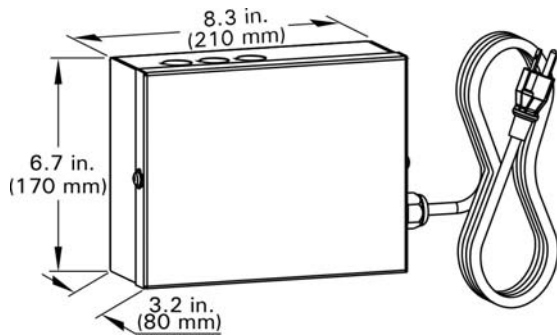

- Rated voltage: 120 VAC
- Rated frequency: 60 Hz
- Rated current: 2 A
- Power consumption: 4 W
- Max. ambient temp.
- at operation: 32 to 104°F (0 to 40°C)
- when storing or transporting: -4 to + 149°F (-20 to + 65°C)
- Relay output for heating circuit pump: 2 A, 120 VAC
- Actuator torque: 3 Nm
- Time of 90°: 120 seconds

Mixing Valve Actuator Kit

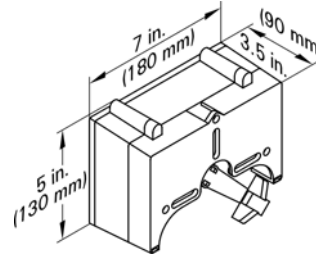

The mixing valve actuator is mounted directly on the Viessmann 3/4 to 2 1/2 in. mixing valve. The mixing valve actuator is a motor-driven control unit. The rotational direction is reversible.

- Rated voltage: 120 VAC
- Rated frequency: 60 Hz
- Power consumption: 4W max. ambient temperature
- at operation: 32° F to 104°F (0° C to 40°C)
- application in living areas and installation sites (normal ambient conditions)
- storage & shipping: -4° F to 149° F (-20°C to 65°C)

AM1 Extension Module

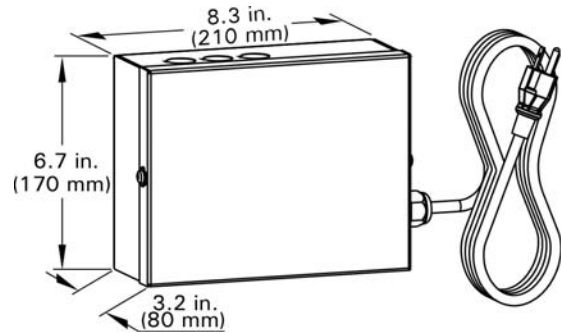

- Rated voltage: 120 VAC
- Rated frequency: 60 Hz
- Rated current: 4A
- Power consumption: 1.5W
- Max. ambient temp.
- at operation: 32 to 104°F (0 to 40°C)
- when storing or transporting: -4 to + 149°F (-20 to + 65°C)
- Relay output for pump: 2A, 120VAC

Optional Accessories *(continued)*

Vitotrol 200A

One Vitotrol 200A can be used for every heating circuit in a heating system. The Vitotrol 200A can regulate one heating circuit and up to two remote controls may be connected to the control unit.

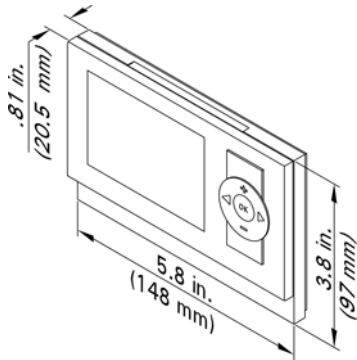

KM BUS Participant

The Vitotrol 200A remote control regulates the required set room temperature in standard mode, from any room in the house.

- Party and economy mode can be enabled via keys
- Only for heating circuit with mixing valve
- Fitted room temperature sensor for room temperature hook-up

WS function:

Installation anywhere in the building.

RS function:

Note: Never activate the RS function for underfloor heating circuits (inertia). In heating systems with a heating circuit without mixing valve and heating circuits with mixing valve, the RS function must only affect the heating circuit with mixing valve.

Room temperature hook-up:

Installation in the main living room on an internal wall opposite radiators. Never install inside shelf units, recesses, immediately by a door or heat source (e.g. direct sunlight, fireplace, TV set, etc.). The integral room temperature sensor captures the actual room temperature and effects any necessary corrections of the supply temperature as well as a rapid heat-up at the start of the heating operation (if appropriately programmed).

Connection:

- 2-core lead 18 AWG, length max. 164 ft. (50 m) (even if connecting several remote control units)
- Never route this lead immediately next to 120/208/460 V cables
- LV plug as standard delivery must be installed in the main living room (lead room).

Specification:

Power supply via KM BUS
 Power consumption: 0.2 W
 Protection class: III

Max. ambient temp.

- at operation: 32 to 104°F (0 to 40°C)
- when storing or transporting: -4 to +149°F (-20 to +65°C)
- Set room temp. range 37 to 99°F (3 to 37°C)

The set room temperature for reduced mode is adjusted at the control unit.

LON Communication Module

Electronic PCB for data exchange with the Vitotronic 200-H, Vitocom 200 and for connecting to a higher level building management system.

LON Connecting Cable

(for data exchange between control units)
 Cable length 23 ft. (7 m), fully wired

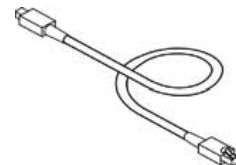

LON Terminal End Resistor

To terminate the LON BUS at the first and the last control unit.

Optional Accessories *(continued)*

Vitotrol 300A

One Vitotrol 300A can be used for every heating circuit in a heating system. The Vitotrol 300A can regulate up to three heating circuits. Up to two remote controls may be connected to the control unit.

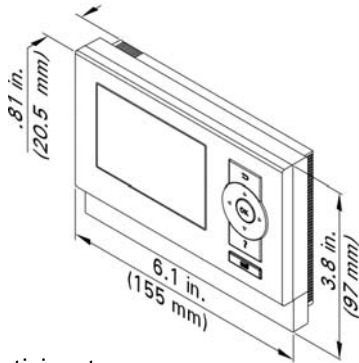

KM BUS Participant

The Vitotrol 300A remote control regulates the required set room temperature for one heating circuit in standard and reduced mode, the heating program and the switching times for central heating, DHW heating and the DHW recirculation pump.

Displaying:

- Room temperature
- Outside temperature
- Heating program
- Operating condition
- Solar yield as graphic display

Settings:

- Set room temperatures for standard mode (day temperature) and reduced mode (night temperature) via the standard display
- Heating program, switching times for heating circuits, DHW heating and DHW recirculation pump plus further settings via plain text menu on the display
- Party and economy mode can be enabled via the menu
- Only for heating circuit with mixer:
Fitted room temperature sensor for room temperature hook-up

Note: For room temperature hook-up, the Vitotrol 300A must be installed in the main living room (lead room).

RS function:

Installation in the main living room on an internal wall opposite radiators. Never install inside shelving units, in recesses, or immediately by a door or heat source (e.g. direct sunlight, fireplace, TV set, etc.). The fitted room temperature sensor captures the actual room temperature and effects any necessary correction of the flow temperature.

WS function:

Installation anywhere in the building.

Connection:

- 2-core lead 18 AWG, length max. 164 ft. (50 m) (even if connecting several remote control units)
- Never route this lead immediately next to 120/208/460V cables
- LV plug as standard delivery must be installed in the main living room (lead room).

Specification:

Power supply via KM BUS

Power consumption: 0.2 W

Protection class: III

Max. ambient temp.

- at operation: 32 to 104°F (0 to 40°C)

- when storing

or transporting: -4 to + 149°F (-20 to + 65°C)

Set room temp. range 37 to 99°F (3 to 37°C)

The set room temperature for reduced mode is adjusted at the control unit.

Accessories for Vitodens 222-F

Fuel Conversion Label Kit (NG > LPG)

(included in boiler technical literature set)

The Vitodens 222-F, B2TB boiler comes factory set for operation with natural gas. All B2TB models can be field converted to operate with liquid propane gas (as well as back to natural gas as required). The kit includes instructions and labels for field conversion.

Low-Loss Header

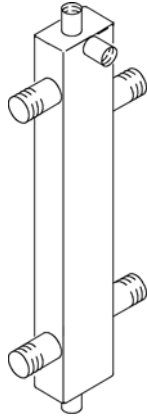

When used in conjunction with the Vitodens 222-F boiler, the low-loss header acts as hydraulic break, decoupling boiler and system circuits from each other. It is recommended to use the low-loss header in applications in which the total system flow rate exceeds the maximum (or minimum) boiler flow rate. For maximum boiler flow rates, see page 8 of this manual.

Viessmann strongly recommends the use of a low-loss header in cases where the system head and flow rates are unknown.

The temperature sensor connection [TS] typically located at the top of the low-loss header ensures low return temperatures to the Vitodens 222-F boiler at all times, increasing operational efficiency.

IMPORTANT

**Use only a Viessmann supplied temperature sensor.
Do not use any other manufacturer's temperature sensor.**

In addition, the low-loss header helps eliminate air and debris [D] from the heating system. See illustrations for design and principle of operation.

Low-loss header design (Typical)

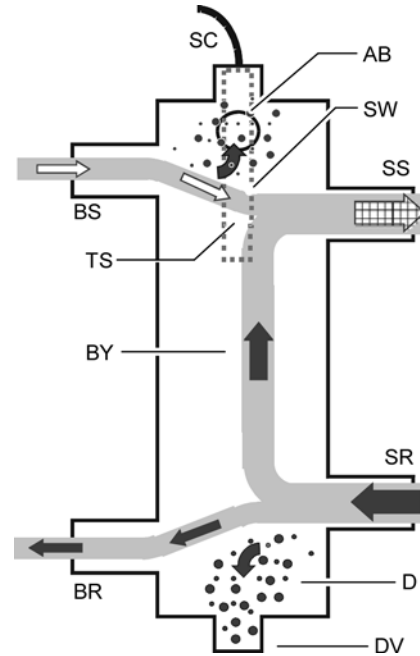

Legend

- AB Air Bleed
- BR Boiler Return
- BS Boiler Supply
- BY Bypass (with laminar flow)
- D Debris and/or air
- DV Drain Valve
- SC Sensor Cable
- SR System Return
- SS System Supply
- TS Viessmann Temperature Sensor
- SW Sensor Well

Accessories for Vitodens 222-F

Low-Loss Header (continued)

Principle of Operation

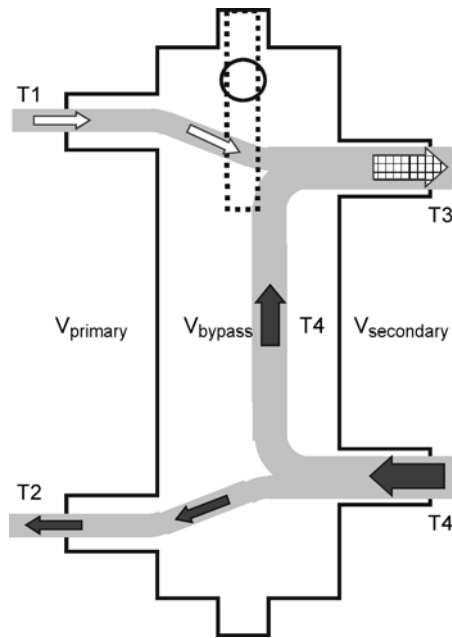

Legend

T1	Boiler supply temperature
T2	Boiler return temperature
T3	System supply temperature
T4	System return temperature
V _{primary}	Boiler circuit flow rate
V _{secondary}	Heating circuit flow rate
V _{bypass}	Bypass flow rate
Q _{primary}	Heat supplied by boiler
Q _{secondary}	Heat consumed by system

IMPORTANT

When installing a low-loss header, the system mixed supply temperature (T3) must be calculated as follows:

$$T3 = \frac{T1 \times V_{primary} + T4 \times V_{bypass}}{V_{secondary}}$$

$$V_{primary} < V_{secondary}$$

$$T1 > T3$$

$$T2 = T4$$

$$Q_{primary} = Q_{secondary}$$

$$T1 \text{ } 167^{\circ} \text{ F (} 75^{\circ} \text{ C)}$$

$$V_{secondary} = V_{primary} + V_{bypass}$$

Model No.	Max. system flow rate
Type 80/60	17.6 GPM (4 m ³ /h)
Type 120/80	35.2 GPM (8 m ³ /h)
Type 160/80 *1	44 GPM (10 m ³ /h)
Type 200/120 *1	80 GPM (18 m ³ /h)

*1 Floor-mounted version (typically used for multiple-boiler installations).

Accessories for Vitodens 222-F

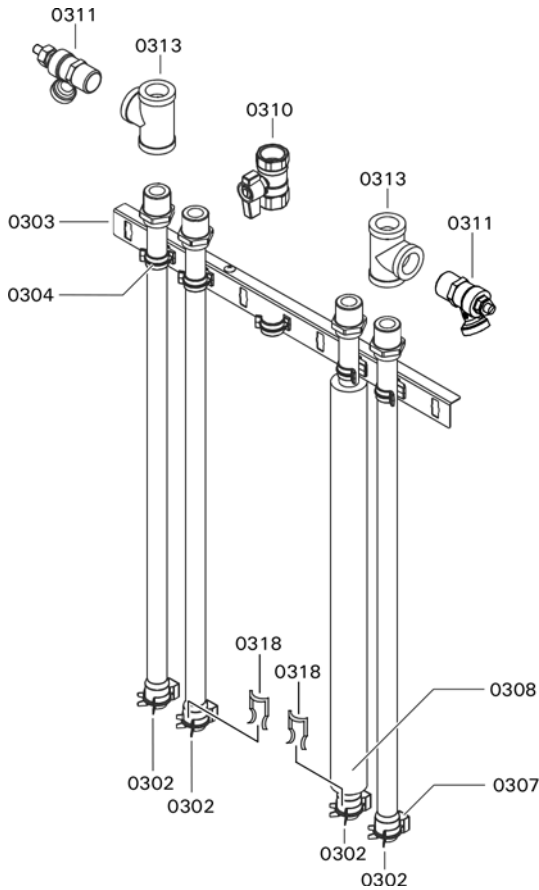

Parts for Top Connection

- 0302 Connecting pipe, DHW/heating
- 0303 Support bracket with pipe clips
- 0304 Pipe clip (each)
- 0307 Connector retaining clip (Set of 2) *1
- 0308 Pipe insulation, 19x9x740 mm
- 0310 Gas ball valve, 3/4 in. brass
- 0311 Sediment faucet, 3/4 in. NPT
- 0313 Tee, 3/4 in. brass
- 0318 Security clips (set of 5) *1, *2

Other Parts (not illustrated)

- 0301 Flex pipe (NG/LP), full-length *3
- 0305 O-Ring, 18x3 mm for supply/return
- 0306 Gasket, 17x24x2 mm for gas connection pipe *3
- 0312 Outdoor temperature sensor, NTC
- 0314 Air bleed key
- 0326 Parts List for Installation Set, top
- 0350 Temperature gauge, 2 in. 30-250°F *4
- 0351 Temperature sensor (immersion) for low-loss header, NTC (if used)

*1 Please ensure security clip (0318) is always installed on connector retaining clip (0307) of the domestic water piping.

*2 Ships affixed to rear of boiler.

*3 The NG/LPG flex pipe (0301) and its gasket (0306) shipped preinstalled on the Vitodens 222-F boiler.

*4 Install anywhere in the supply piping near the boiler.

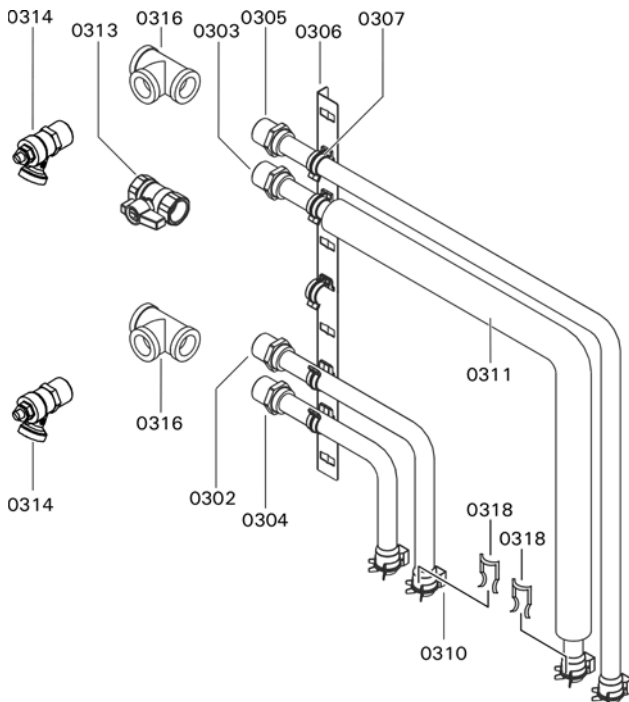

Parts for Left/Right Side Connection

- 0302 Connecting pipe 90°, DHW short
- 0303 Connecting pipe 90°, DHW long
- 0304 Connecting pipe 90°, heating short
- 0305 Connecting pipe 90°, heating long
- 0306 Support bracket with pipe clips
- 0307 Pipe clip (each)
- 0310 Connector retaining clip (Set of 2) *1
- 0311 Pipe insulation, 19x9x740 mm
- 0313 Gas ball valve, 3/4 in. brass
- 0314 Sediment faucet, 3/4 in. NPT
- 0316 Tee, 3/4 in. brass
- 0318 Security clips (set of 5) *1, *2

Other Parts (not illustrated)

- 0301 Flex pipe (NG/LP), full-length *3
- 0308 O-Ring, 18x3 mm for supply/return
- 0309 Gasket, 17x24x2 mm for gas connection pipe *3
- 0315 Outdoor temperature sensor, NTC
- 0317 Air bleed key
- 0325 Parts List for Installation Set, left/right
- 0350 Temperature gauge, 2 in. 30-250°F *4
- 0351 LLH temperature sensor, immersion NTC (if used)

*1 Please ensure security clip (0318) is always installed on connector retaining clip (0310) of the domestic water piping.

*2 Ships affixed to rear of boiler.

*3 The NG/LPG flex pipe (0301) and its gasket (0309) shipped preinstalled on the Vitodens 222-F boiler.

*4 Install anywhere in the supply piping near the boiler.

Standard Equipment

The Vitodens 222-F gas-fired condensing combi-boiler with Inox-Radial heat exchanger, modulating MatriX cylinder burner for liquid propane gas and natural gas (available on all models), comes standard with:

- stainless steel DHW tank
- pressure gage
- relief valve and air vent and heat exchanger bleeding valve
- Integral diaphragm expansion tank
- boiler control unit with outdoor temperature sensor, power/pump module:
 - installation fittings with 30 psig pressure
 - LLH temperature sensor. Thermometer gauge field installation on supply pipe.
 - The boiler comes prewired and fully piped internally for field connections and prewired.
 - Side wall vent installations must include Viessmann protective screen!
 - Enclosure finish: black steel, powder-coated white
 - The Vitodens 222-F comes ready for use with natural gas and can be fuel converted to liquid propane gas in the field.

Combustion Management System

The combustion management system utilizes the physical correlation between the level of the ionization current and the air factor λ . For all gas qualities, the maximum ionization current results with air factor λ .

The ionization signal is evaluated by the combustion management system, and the air factor is adjusted to between $\lambda = 1.24$ and 1.44 . This range provides for an optimum combustion quality. Thereafter, the electronic gas valve regulates the required gas volume based on the prevailing gas quality.

To check the combustion quality, the CO₂ content or the O₂ content of the flue gas is measured. The actual values enable the prevailing air factor to be determined. The relationship between the CO₂ or O₂ content and air factor λ is illustrated in the table below.

Air factor λ - CO₂/O₂ content

Air factor λ	O ₂ content (%)	CO ₂ content (%) for natural gas	CO ₂ content (%) for liquid propane gas
1.20	3.8	9.6	11.3
1.24	4.4	9.2	10.9
1.27	4.9	9.0	10.6
1.30	5.3	8.7	10.3
1.34	5.7	8.5	10.0
1.37	6.1	8.3	9.8
1.40	6.5	8.1	9.6
1.44	6.9	7.8	9.3
1.48	7.3	7.6	9.0

The Vitodens 222-F, B2TB boilers come equipped with Lambda Pro, the industry’s first intelligent combustion management system. The boiler adjusts automatically to any gas type and quality without the need for a fuel conversion kit.

To achieve an optimum combustion control, the system regularly performs an automatic self-calibration; also after a power failure (shutdown). For this, the combustion is briefly regulated to max. ionization current (equals air factor $\lambda = 1$). The automatic calibration is performed shortly after the burner starts and lasts approximately 5 seconds. During the calibration, higher than normal CO emissions may occur briefly.

The combustion management system can also be calibrated manually, e.g. after maintenance or service work (coding address “85”, see Service Instructions).

Hydraulic Connection

System design

Viessmann condensing boilers can generally be installed in any pumped hot water heating system (closed system). The circulation pump is an integral part of the appliance. Minimum system pressure 14 psi.

The boiler water temperature is limited to 180°F (82°C). To minimise distribution losses, we recommend that you size the heat distribution system to a max. supply temperature of 158°F (70°C).

For apartments with less than 860 ft² (80 m²) living space or for low energy houses with low heat demand we recommend, due to the immediate capturing of the room-influencing factors, the utilisation of the Vitodens with a constant temperature control unit in conjunction with the Vitotrol 100.

To reduce burner cycling in low energy houses with a correspondingly low heat demand, we recommend the use of a low loss header.

Installation Examples

Please note that in the following piping layout examples all pumps external to the boiler are field supplied.

IMPORTANT

The examples on the following pages depict possible piping layouts of the Vitodens 222-F boiler equipped with Viessmann System Technology.

Please note that the following examples are simplified conceptual drawings only!

Piping and necessary componentry must be field verified. A low water cut-off (LWCO) must be installed where required by local codes.

Proper installation and functionality in the field is the responsibility of the heating contractor.

System Layout 1

Vitodens 222-F, B2TB with a direct-connected heating circuit with integrated DHW production

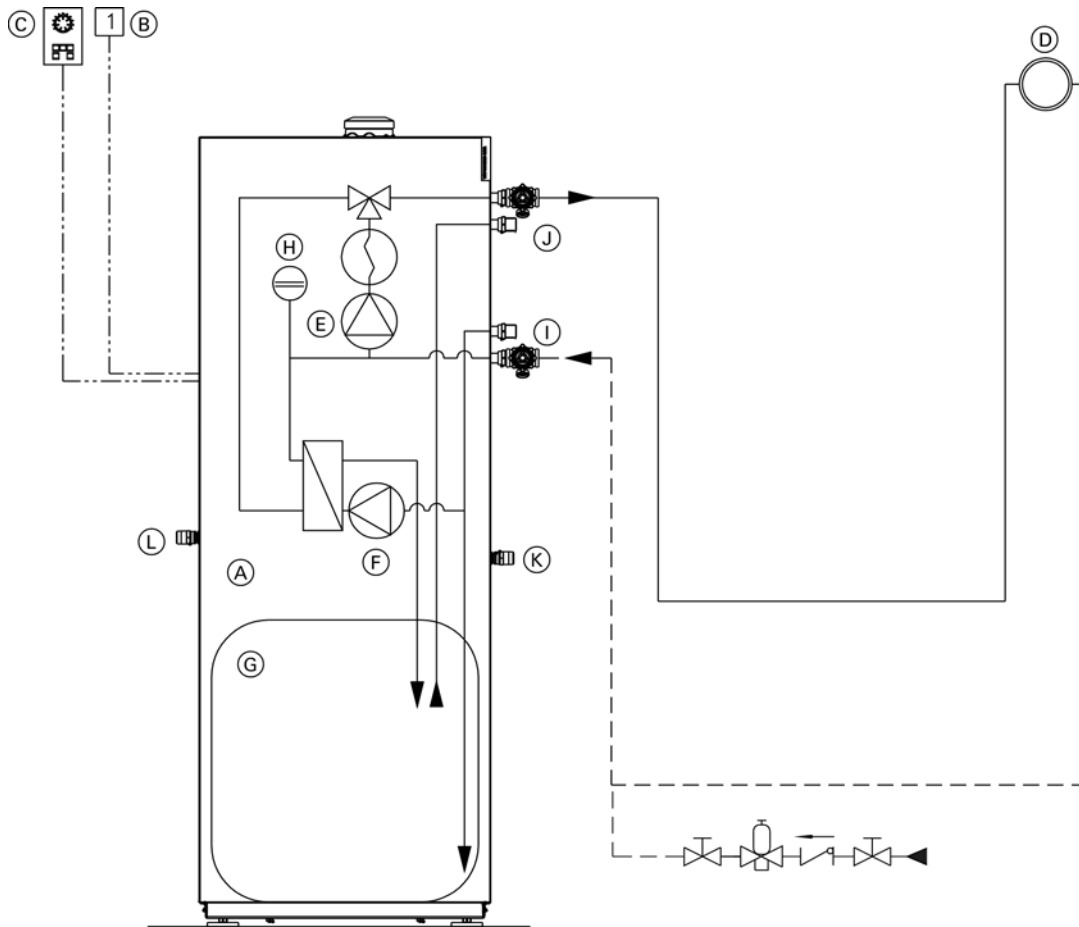

Legend

- (A) Vitodens 222-F B2TB boiler with Vitotronic 200, HO1B outdoor reset control
- (B) Outdoor temperature sensor [1]
- (C) Vitotrol remote (optional)
- (D) Heating circuit
- (E) Boiler pump [20]
- (F) DHW circulating pump [21]
- (G) DHW storage tank
- (H) Integral expansion tank
- (I) DCW inlet
- (J) DHW outlet
- (K) Temperature and pressure relief valve outlet
- (L) Pressure relief valve outlet

Installation of ...

- radiator heating circuit (high-temp. circuit)
- DHW production

... with the following flow conditions:

The flow rate of the heating circuit is less than the maximum possible water flow rate of the Vitodens 222-F B2TB boiler (see page 8 for maximum water flow rate of boiler).

The use of a low-loss header is strongly recommended if the maximum water flow rate in the application concerned exceeds the values shown in the applicable table on page 8, or if the system flow rates are unknown. The low-loss header is available as accessory part.

See following pages for installation examples with a low-loss header.

System Layout 2

Vitodens 222-F, B2TB with one heating circuit, low-loss header and integrated DHW production

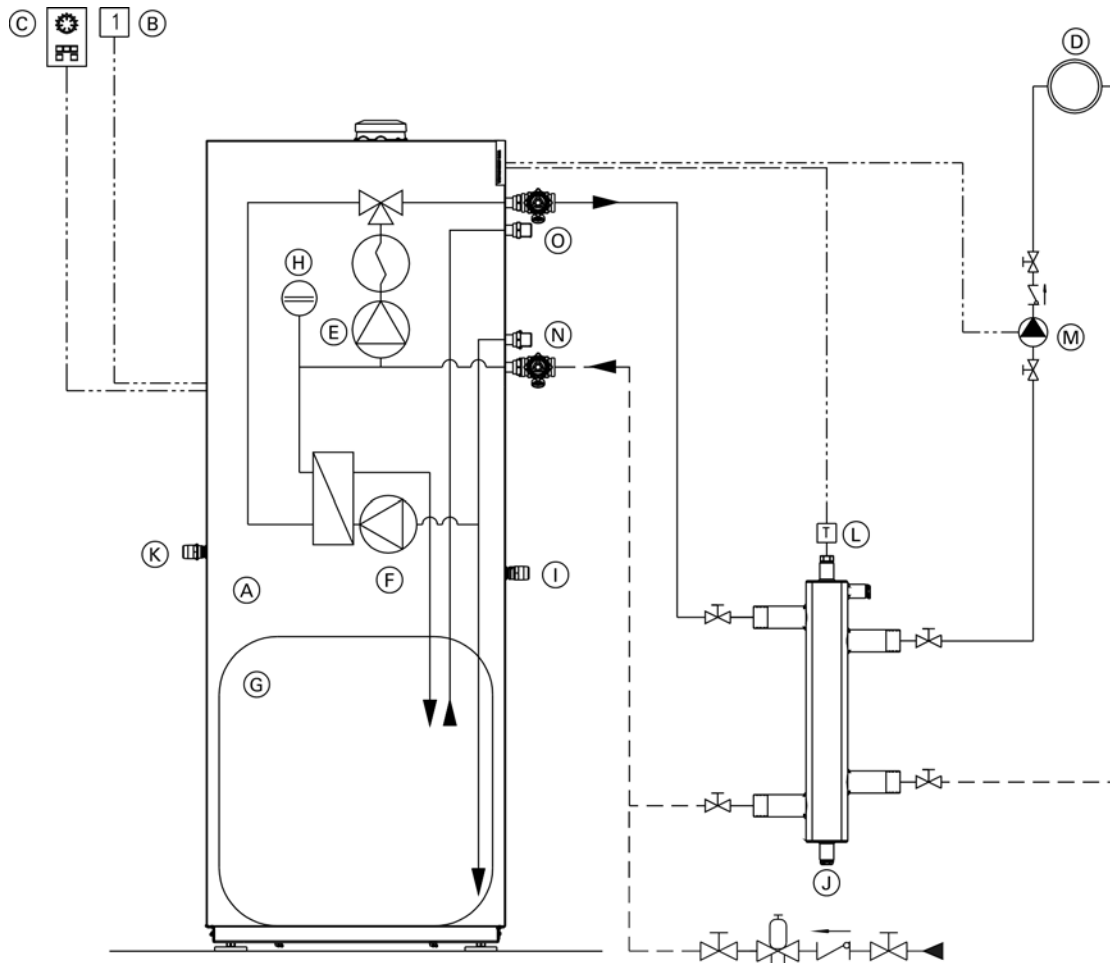

Legend

- (A) Vitodens 222-F B2TB boiler with Vitotronic 200, HO1B outdoor reset control
- (B) Outdoor temperature sensor [1]
- (C) Vitotrol remote (optional)
- (D) Heating circuit
- (E) Boiler pump [20]
- (F) DHW circulating pump [21]
- (G) DHW storage tank
- (H) Integral expansion tank
- (I) Temperature and pressure relief valve outlet
- (J) Low-loss header
- (K) Pressure relief valve outlet
- (L) Viessmann temperature sensor for low-loss header [2]
- (M) Heating circuit pump [28/20]
- (N) DCW inlet
- (O) DHW outlet

Installation of ...

- radiator heating circuit (high-temp. circuit)
- DHW production

... with the following flow conditions:

The flow rate of the heating circuit is greater than the maximum possible water flow rate of the Vitodens 222-F B2TB boiler (see page 8 for maximum water flow rate of boiler).

The use of a low-loss header is strongly recommended if the maximum water flow rate in the application concerned exceeds the values shown on page 8, or if the system flow rates are unknown.

The low-loss header is available as accessory part.

System Layout 3

Vitodens 222-F, B2TB with...

- Integrated DHW production
- one heating circuit with mixing valve and system separation

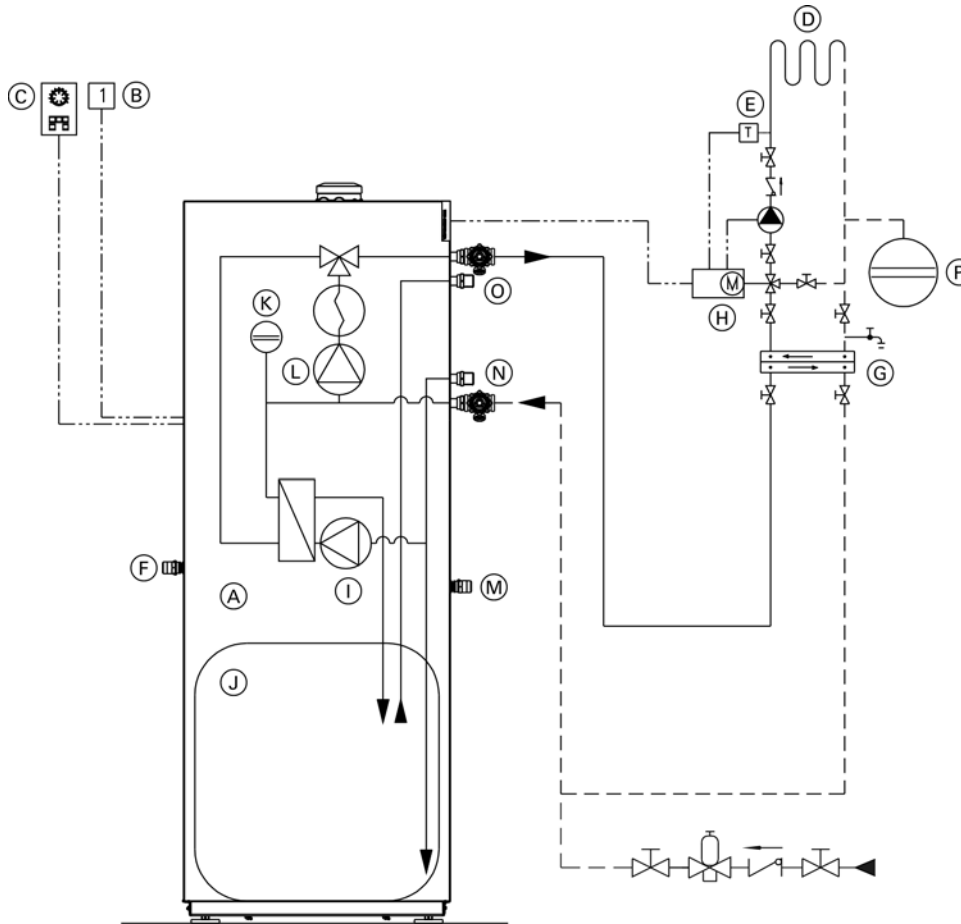

Legend

- (A) Vitodens 222-F B2TB boiler with Vitotronic 200, HO1B outdoor reset control
- (B) Outdoor temperature [1]
- (C) Vitotrol remote (optional)
- (D) Underfloor heating circuit
- (E) Mixing valve temperature sensor [2]
- (F) Pressure relief valve outlet
- (G) Plate heat exchanger for system separation
- (H) Accessory kit for heating circuit with mixing valve
- (I) DHW circulating pump [21]
- (J) DHW storage tank
- (K) Integral expansion tank
- (L) Boiler pump [20]
- (M) Temperature and pressure relief valve outlet
- (N) DCW inlet
- (O) DHW outlet
- (P) Expansion tank

Installation of ...

- underfloor heating circuit with 3-way mixing valve and system separation (low-temp. circuit)
- DHW production

... with the following flow conditions:

The flow rate of the heating circuit is less than the maximum possible water flow rate of the Vitodens 222-F B2TB boiler.

See page 8 for maximum water flow rate of the Vitodens 222-F B2TB boilers. The use of a low-loss header is recommended if the system water flow rate is unknown. The low-loss header is available as accessory part.

See following pages for installation examples with a low-loss header.

IMPORTANT

System separation is required of underfloor heating systems employing non-oxygen diffusion barrier tubing. All components on the secondary side of the heat exchanger must be made of corrosion-resistant materials.

System Layout 4

Vitodens 222-F, B2TB with...

- Integrated DHW production
- one direct-connected heating circuit
- one heating circuit with a mixing valve

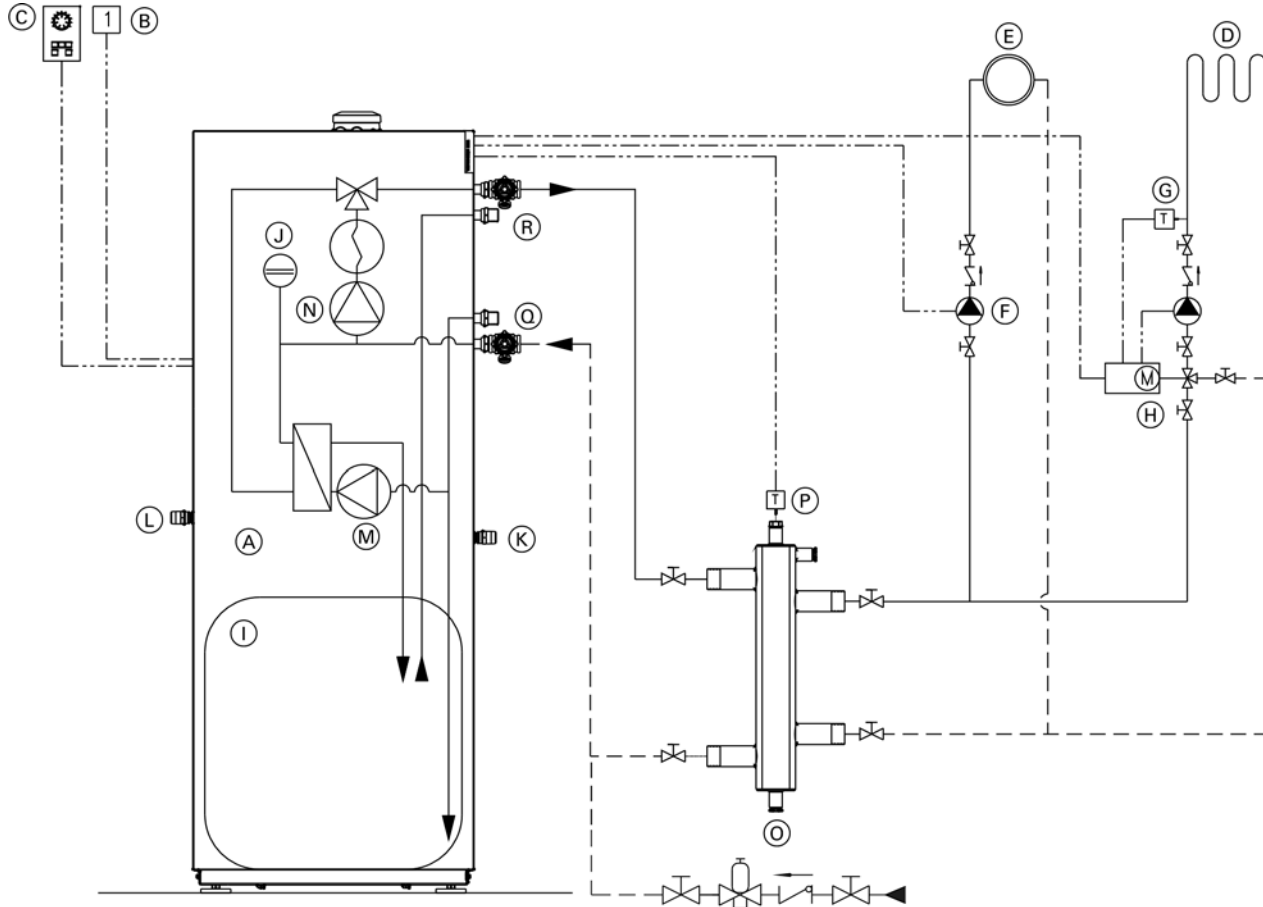

Legend

- (A) Vitodens 222-F B2TB boiler with Vitotronic 200, HO1B outdoor reset control
- (B) Outdoor temperature sensor [1]
- (C) Vitotrol remote (optional)
- (D) Under floor heating circuit
- (E) Radiator heating circuit
- (F) Heating circuit pump [28/20]
- (G) Mixing valve temperature sensor [2]
- (H) Accessory kit for heating circuit with mixing valve
- (I) Domestic hot water storage tank
- (J) Integral expansion tank
- (K) Temperature and pressure relief valve outlet
- (L) Pressure relief valve outlet
- (M) DHW circulating pump [21]
- (N) Boiler pump [20]
- (O) Low-loss header
- (P) Low-loss header sensor [2]
- (Q) DCW inlet
- (R) DHW outlet

Installation of different heating circuits...

- radiator heating circuit (high-temp. circuit)
- under floor heating circuit with 3-way mixing valve (low-temp. circuit)
- DHW production

... with the following flow conditions:

1. The water flow rate (output) of the radiator heating circuit is at least 30% greater than that of the under floor heating circuit.
2. The total flow rate of the two heating circuits is less than the maximum possible water flow rate of the Vitodens 222-F B2TB boiler (see page 8 for max. water flow rate).
The use of a low-loss header is strongly recommended if the maximum water flow rate in the application concerned exceeds the values shown on page 8, or if the system flow rates are unknown.
The low-loss header is available as accessory part.

The 3-way mixing valve, built-in to achieve the low-temperature level of the under floor heating circuit, is controlled by an accessory kit for a heating circuit with mixing valve.

System Layout 5

Vitodens 222-F, B2TB with...

- Integrated DHW production
- one heating circuit with mixing valve
- one heating circuit without mixing valve and low-loss header

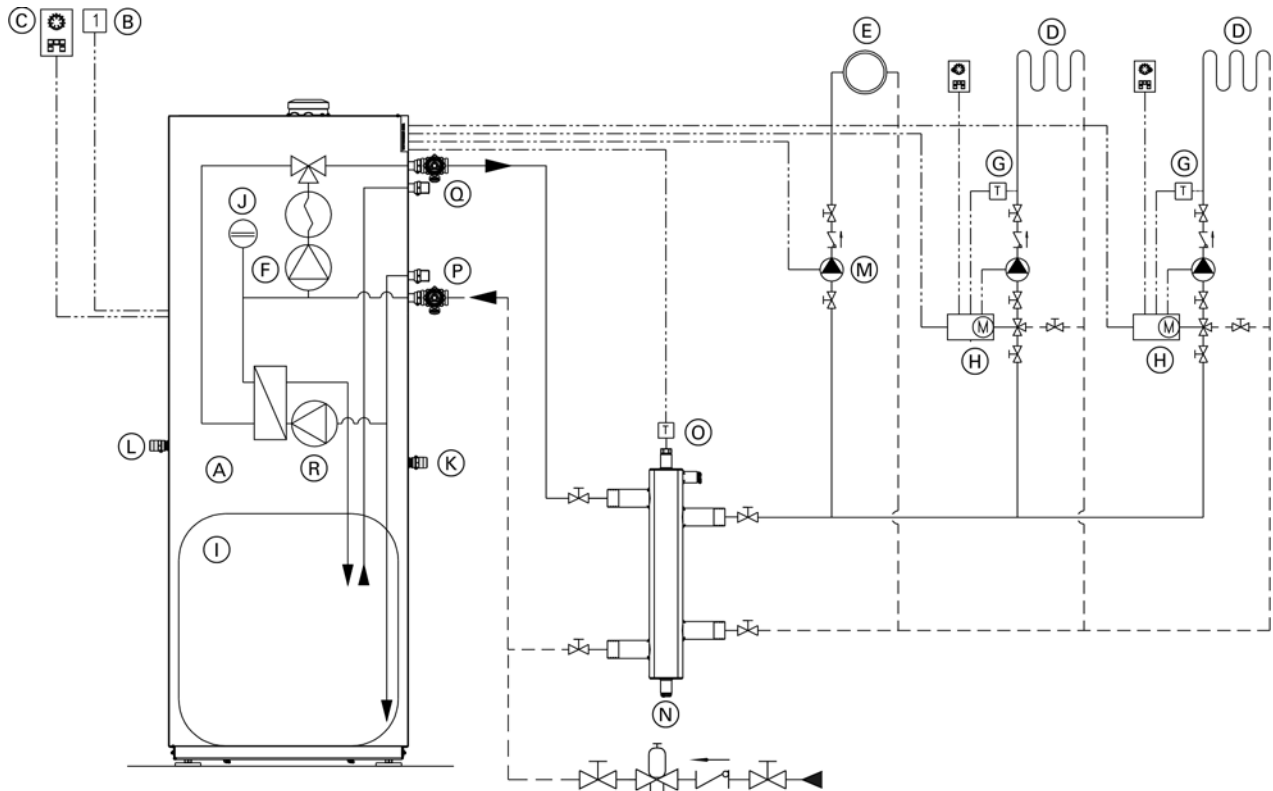

Legend

- (A) Vitodens 222-F B2TB boiler with Vitotronic 200, HO1B outdoor reset control
- (B) Outdoor temperature sensor [1]
- (C) Vitotrol remote (optional)
- (D) Under floor heating circuit
- (E) Radiator heating circuit
- (F) Boiler pump [20]
- (G) Mixing valve temperature sensor [2]
- (H) Kit for heating circuit with mixing valve
- (I) Domestic hot water storage tank
- (J) Integral expansion tank
- (K) Temperature and pressure relief valve outlet
- (L) Pressure relief valve outlet
- (M) Heating pump [28/20]
- (N) Low-loss header
- (O) Viessmann temperature sensor for low-loss header [2]
- (P) DCW inlet
- (Q) DHW outlet
- (R) DHW circulating pump [21]

Installation of different heating circuits...

- radiator heating circuit (high-temp. circuit)
- under floor heating circuit with 3-way mixing valve (low-temp. circuit)
- DHW production

... with the following flow conditions:

The total flow rate of the two heating circuits is greater than the maximum possible water flow rate of the Vitodens 222-F B2TB boiler (see page 8 for maximum water flow rate of boiler).

The use of a low-loss header is strongly recommended. The low-loss header is available as accessory part.

The 3-way mixing valve, built-in to achieve the low-temperature level of the under floor heating circuit, is controlled by an accessory kit for a heating circuit with mixing valve.

System Layout 6

Vitodens 222-F, B2TB with...

- Integrated DHW production
- one direct-connected heating circuit
- one heating circuits with system separation

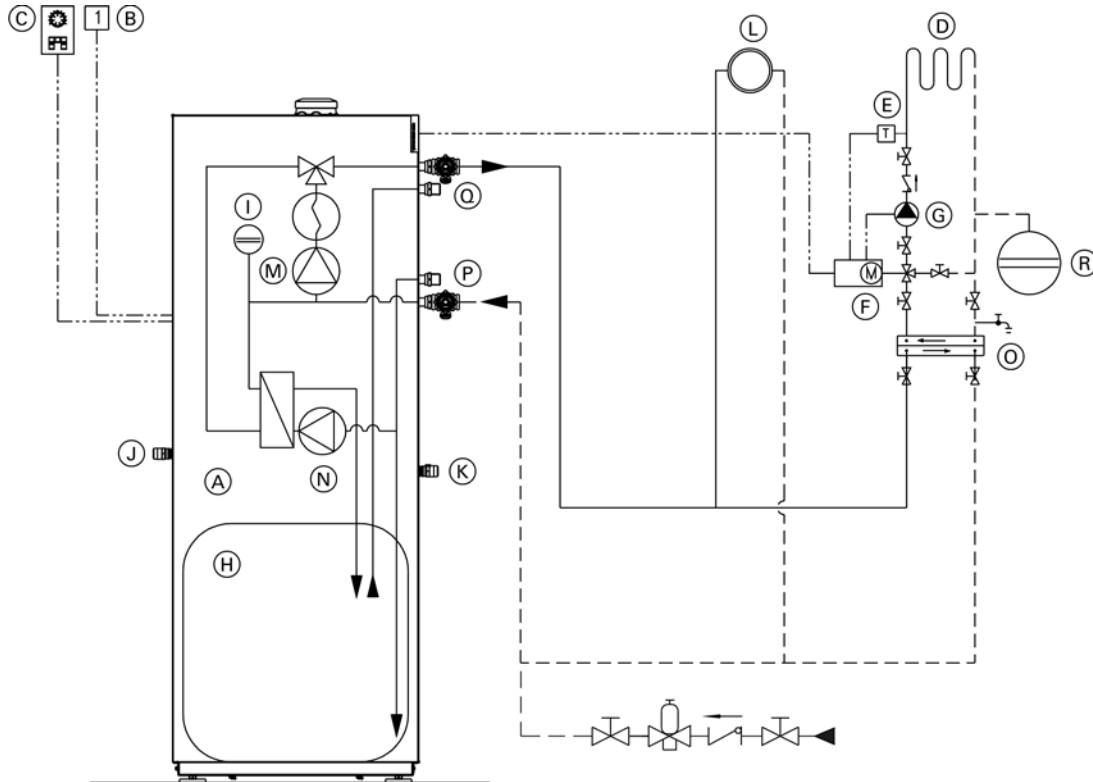

Legend

- (A) Vitodens 222-F B2TB boiler with Vitotronic 200, HO1B outdoor reset control
- (B) Outdoor temperature sensor 1
- (C) Vitotrol remote (optional)
- (D) Under floor heating circuit
- (E) Mixing valve temperature sensor 2
- (F) Accessory kit for heating circuit with mixing valve
- (G) Heating circuit pumps
- (H) DHW storage tank
- (I) Integral expansion tank
- (J) Pressure relief valve outlet
- (K) Temperature and pressure relief valve outlet
- (L) Radiator heating circuit
- (M) Boiler pump 20
- (N) DHW circulating pump 21
- (O) Plate exchanger for system separation
- (P) DCW inlet
- (Q) DHW outlet
- (R) Expansion tank

Installation of different heating circuits...

- two heating circuits with 3-way mixing valve (low-temp. circuit)
- DHW production

... with the following flow conditions:

The total flow rate of the two heating circuits is greater than the maximum possible water flow rate of the Vitodens 222-F B2TB boiler (see page 8 for maximum water flow rate of boiler).

The use of a low-loss header is strongly recommended. The low-loss header is available as accessory part.

The 3-way mixing valve, built-in to achieve the low-temperature level of the under floor heating circuit, is controlled by an accessory kit for a heating circuit with a mixing valve.

System Layout 7

Vitodens 222-F, B2TB with...

- one direct-connected heating circuit
- three heating circuit with mixing valve and integrated DHW production

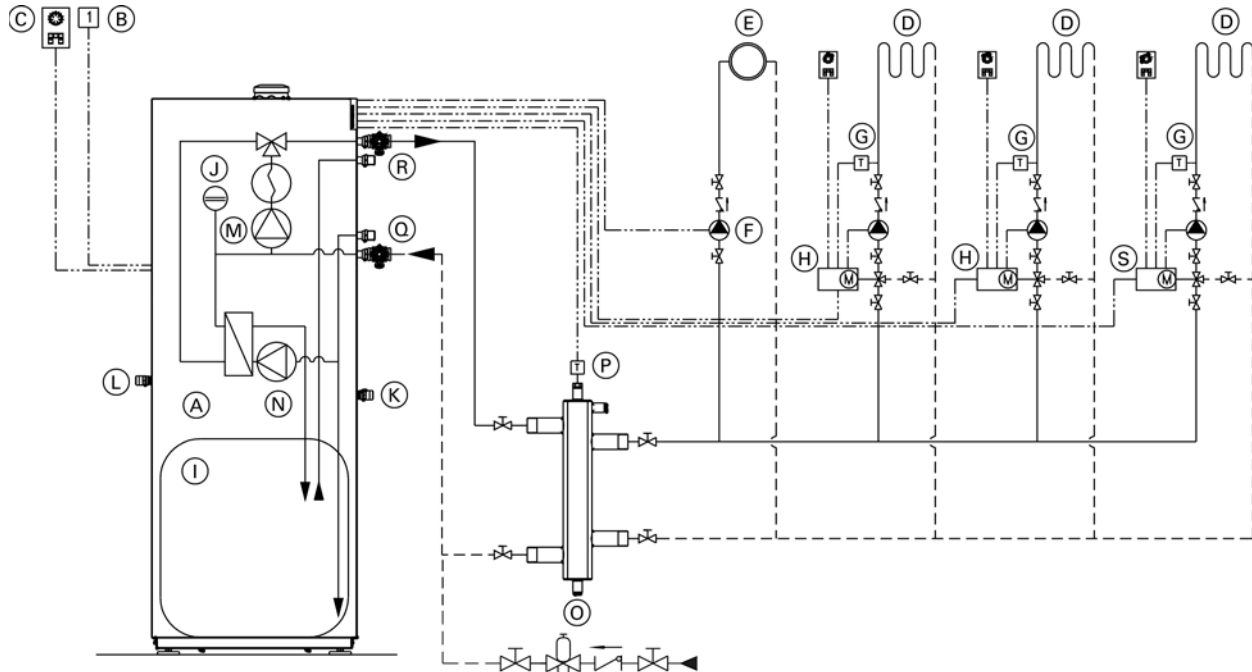

Legend

- (A) Vitodens 222-F B2TB boiler with Vitotronic 200, HO1B outdoor reset control
- (B) Outdoor temperature sensor [1]
- (C) Vitotrol remote (optional)
- (D) Under floor heating circuit
- (E) Radiator heating circuit
- (F) Heating circuit pump [28/20]
- (G) Mixing valve temperature sensor [2]
- (H) Accessory kit for heating circuit with mixing valve
- (I) DHW storage tank
- (J) Integral expansion tank
- (K) Temperature and pressure relief valve outlet
- (L) Pressure relief valve outlet
- (M) Boiler pump [20]
- (N) DHW circulating pump [21]
- (O) Low-loss header
- (P) Low-loss header sensor [2]
- (Q) DCW inlet
- (R) DHW outlet
- (S) Vitotronic 200-H HK1B

Installation of different heating circuits...

- radiator heating circuit (high-temp. circuit)
- under floor heating circuit with 3-way mixing valve (low-temp. circuit)
- DHW production

... with the following flow conditions:

The total flow rate of the two heating circuits is less than the maximum possible water flow rate of the Vitodens 222-F B2TB boiler (see page 8 for maximum water flow rate of boiler).

The use of a low-loss header is strongly recommended if the maximum water flow rate in the application concerned exceeds the max. boiler flow rate, or if the system flow rates are unknown. The low-loss header is available as accessory part.

System Layout 8

- Vitodens 222-F, B2TB with...
- Integrated DHW production
 - three zone circuits

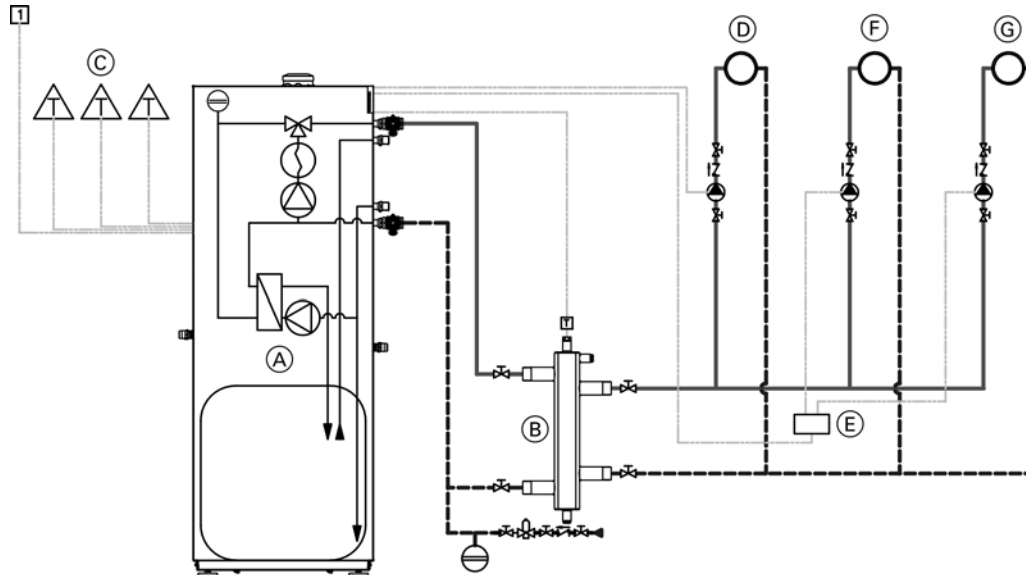

Legend

- (A) Vitodens 222-F boilers
- (B) Low-loss header
- (C) Thermostat zone circuits 1, 2, 3
- (D) Zone circuit 1 [output 157]
- (E) AM1 extension module (accessory)
- (F) Zone circuit 2 [output A1 - AM1 extension module]
- (G) Zone circuit 3 [output A2 - AM1 extension module]

Installation of different heating circuits...

- DHW production
- 3 zone circuits

... with the following flow conditions:

The total flow rate of the two heating circuits is greater than the maximum possible water flow rate of the Vitodens 222-F B2TB boiler.

The use of a low-loss header is strongly recommended.

The low-loss header is available as accessory part.

IMPORTANT

System separation is required of underfloor heating systems employing non-oxygen diffusion barrier tubing. All components on the secondary side of the heat exchanger must be made of corrosion-resistant materials.

Alternative Connection

The following piping diagram reflects the connection for the DHW system to boiler.

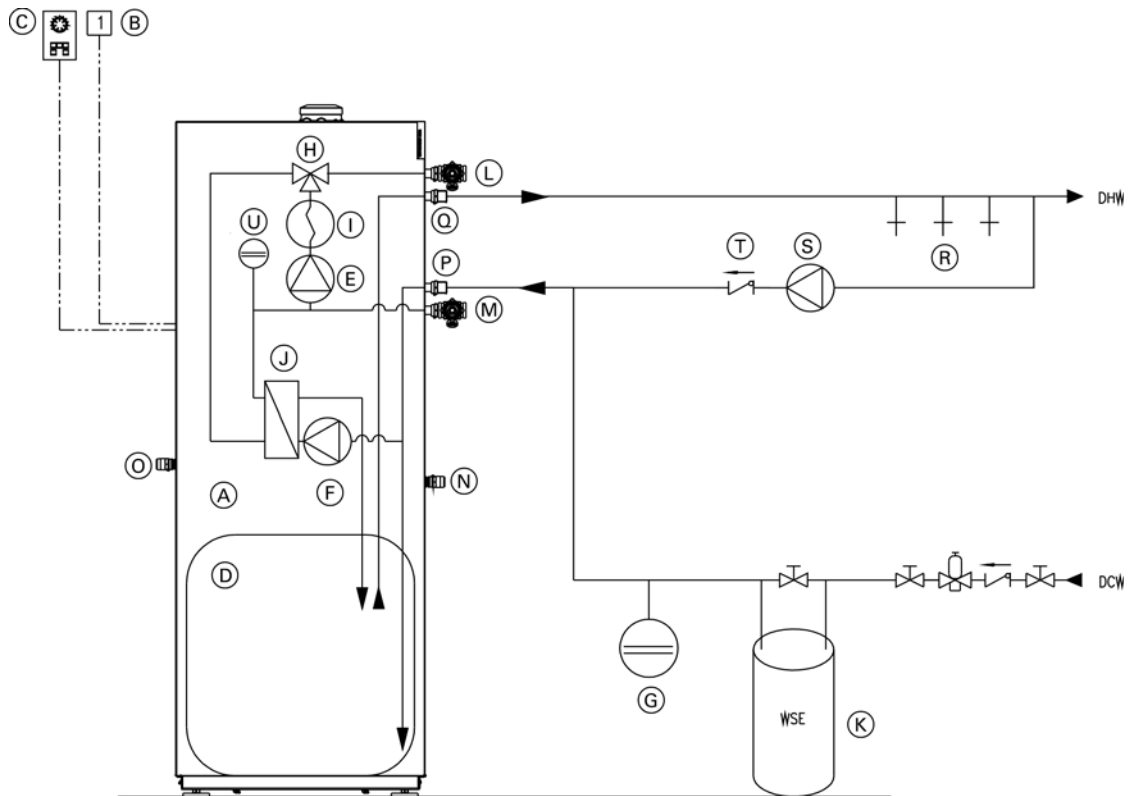

Legend

- (A) Boiler
- (B) Outdoor temperature sensor [1]
- (C) Vitotrol remote (optional)
- (D) DHW storage tank
- (E) Boiler pump [20]
- (F) DHW circulating pump [21]
- (G) Expansion tank
- (H) Diverting valve
- (I) Boiler heat exchanger
- (J) DHW heat exchanger
- (K) Water softener
- (L) Boiler supply
- (M) Boiler return
- (N) Temperature and pressure relief valve outlet
- (O) Pressure relief valve outlet
- (P) DCW inlet
- (Q) DHW outlet
- (R) DHW users
- (S) DHW recirculation pump
- (T) Flow check valve
- (U) Integral expansion tank

Overview of Electrical Connections, Models B2TB 19, 35, 68, 125

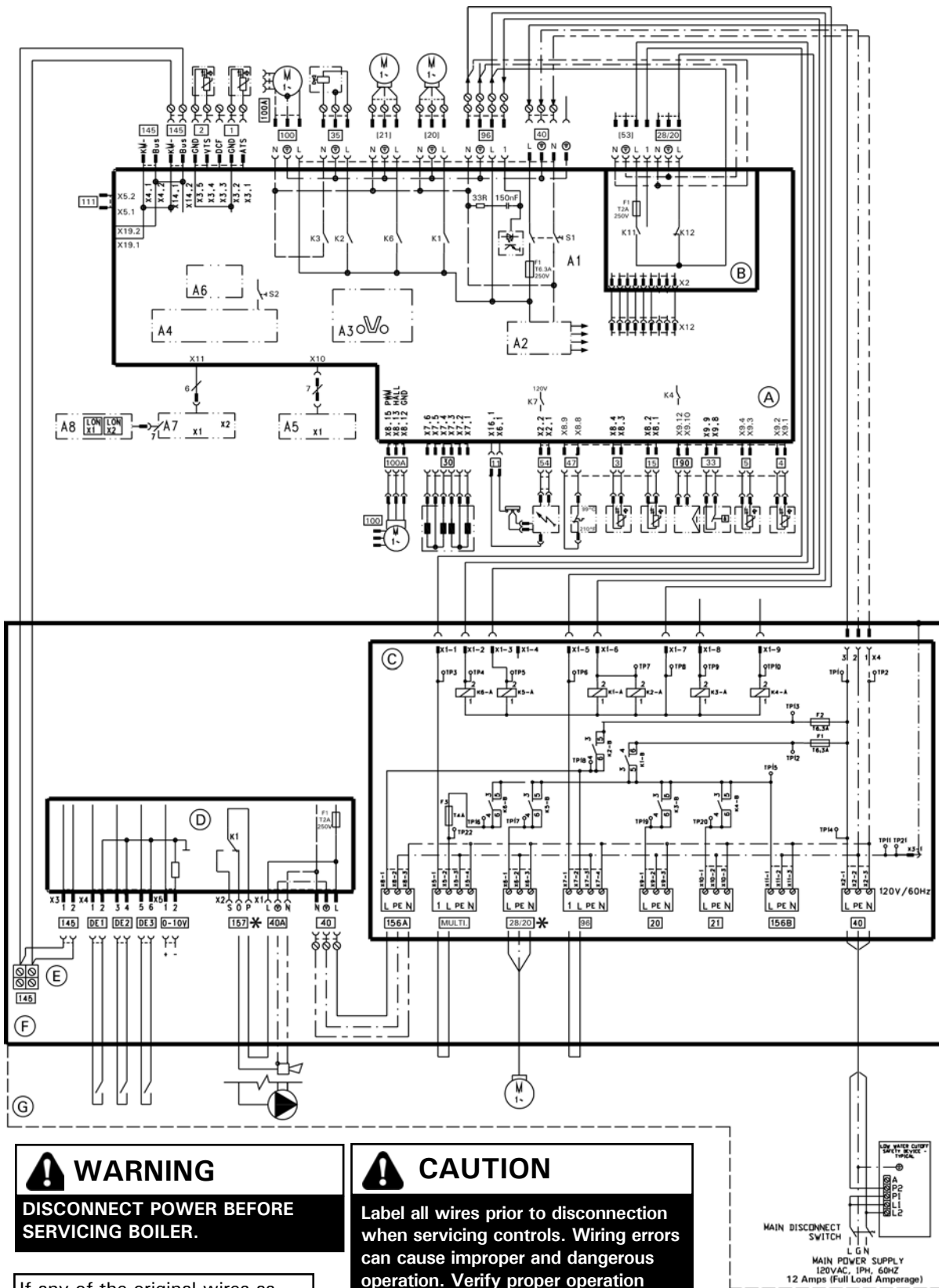

⚠ WARNING
DISCONNECT POWER BEFORE SERVICING BOILER.

If any of the original wires as supplied with the appliance must be replaced, it must be replaced with the exact equivalent.

⚠ CAUTION
 Label all wires prior to disconnection when servicing controls. Wiring errors can cause improper and dangerous operation. Verify proper operation after servicing.

* Only one function/connection may be assigned to each connection.

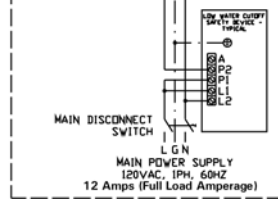

Overview of Electrical Connections, Models B2TB 19, 35, 68, 125 *(continued)***Legend**

1	Outdoor Temperature Sensor
2	Supply Temperature Sensor/Low Loss Header
3	Boiler Temperature Sensor
4	DHW Supply Temperature Sensor
5	DHW Tank Temperature Sensor
11	Ionization Electrode
15	Flue Gas Temperature Sensor
20	No Function
[20]	Boiler Pump Connection (Internal)
21	No Function
[21]	DHW Pump Connection (Internal)
28/20	Heat Circuit Pump Connection / Zone Circuit Pump*
30	Diverting Valve Stepper Motor
33	Flow Switch
35	Gas Valve
40	Power Supply
40A	Accessory Power Output
47	Fixed High Limit
[53]	Powered Accessory Connection
54	Ignition Transformer
96	Powered Accessory Connection
100	Fan Motor
100A	Fan Motor Control
111	Not Used
145	KM BUS
Multi	Powered Accessory Connection
156A	Switched Output F2
156B	Switched Output F1
DE1	Digital Input 1 (Dry Contact)
DE2	Digital Input 2 (Dry Contact)
DE3	Digital Input 3 (Dry Contact)
0-10V	0-10VDC Input
157	Fault Alarm/DHW Recirc. Pump / Heating or Zone Circuit Pump*
190	Gas Modulation Coil

* Only one function/connection may be assigned to each connection.

- Ⓐ Boiler Control
- Ⓑ External Accessory Connection Board
- Ⓒ Pump Connection Interface
- Ⓓ Extension Module EA1
- Ⓔ KM-BUS for External Devices
- Ⓕ Electrical Junction Box
- Ⓖ Field Wiring Connections
- A1 Main Board
- A2 Internal Power Supply Unit
- A3 Optolink
- A4 Burner Control Unit
- A5 Programming Unit
- A6 Coding Card
- A7 Connection Adaptor
- A8 LON Communication Module
- S1 ON/OFF Switch
- S2 Reset Button
- X.. Electrical Interface

IMPORTANT

Electrical installations must comply with the latest edition of:

- In the U.S.A., the National Electrical Code (NEC), ANSI/NFPA 70 and any other state, local codes and/or regulations.
- In Canada, the Canadian Electrical Code (CEC), CSA C22.1 Part 1 and any other province, territory, local codes and/or regulations.

System Design Considerations

IN THE COMMONWEALTH OF MASSACHUSETTS...

- this product shall be installed by a licensed plumber or gas fitter.
- the flexible connector (if used) cannot exceed 36".
- any level type shutoff used must be of tee handle type.

Boiler location

As a direct vent appliance, the Vitodens 222-F can be installed for room air independent operation (sealed combustion) regardless of size and ventilation method of the room in which it is located.

The Vitodens 222-F can be installed, for example, in the main living area of a house, in non-ventilated utility rooms, cupboards, closets and alcoves with no clearance required from combustible materials, as well as in attics with a direct outlet for the flue gas/fresh air system. Follow all local and national codes.

Flue gas system

Viessmann PPS (Polypropylene) concentric flue gas/fresh air systems for room air independent operation (sealed combustion) and side wall venting are tested to ANSI Z21.13 - CSA 4.9 - 2000 standards and are certified together with the Vitodens 222-F boiler as a constructional unit.

The Vitodens 222-F boiler may also be vented vertically, using an AL29-4C® special stainless steel, single-wall, room air dependent venting system (UL listed for category IV). For a more detailed description of the direct vent and single-wall vent system, please refer to the Vitodens 222-F Venting System Installation Instructions.

Flue gas temperature protection

Flue pipes used for the Vitodens 222-F are suitable for max. flue gas temperatures of up to 230°F (110°C). No flue gas temperature protection is required as the maximum permissible flue gas temperature is not exceeded in any operating condition or in the event of malfunctioning.

Low water cut-off

The Vitodens 222 boiler is certified with an internal flow switch / sensor, however a low water cut-off may be required by local jurisdiction.

If required, an approved type low water cut-off device must be provided by the heating contractor.

Do not install an isolation valve between the boiler and the low water cut-off.

Water connections

Vitodens 222-F boilers can be used in any fully pumped hot water heating system.

Minimum system pressure is 14 psig.

Chemical corrosion protection products

Corrosion does not typically occur in sealed heating systems which have been correctly installed and are correctly operated.

Many manufacturers of plastic pipes recommend the use of chemical additives. In this case, only those commercially available corrosion protection products approved for boilers with domestic hot water heating via single-wall heat exchangers (instantaneous plate heat exchangers or DHW tanks) must be used.

Water quality

Treatment for boiler feed water should be considered in areas of known problems, such as where a high mineral content and hardness exist. In areas where freezing might occur, an antifreeze may be added to the system water to protect the system. Please adhere to the specifications given by the antifreeze manufacturer. Do not use automotive silicate based antifreeze.

Please observe that an antifreeze/water mixture may require a backflow preventer within the automatic water feed and influence components such as diaphragm expansion tanks, radiation, etc. Maximum antifreeze content is 50% for the Vitodens 222-F boiler. Do not use antifreeze other than specifically made for hot water heating systems. System also may contain components which might be negatively affected by antifreeze.

Check total system frequently when filled with antifreeze. Advise system operator/ultimate owner that system is filled with a glycol mix. The heating contractor must provide a MSDS (Material Safety Data Sheet) for the antifreeze used to the system operator/ultimate owner.

Total permissible hardness of the fill and top-up water

Total heating output	Specific heating volume					
	< 5 USG per 3412 BTU		≥ 5 USG per 3412 BTU to < 13 USG per 3412 BTU		≥ 13 USG per 3412 BTU	
MBH						
≤ 170	300 ppm	17.5 gpg	200 ppm	11.7 gpg	2 ppm	0.11 gpg
> 170 to ≤ 682	200 ppm	11.7 gpg	150 ppm	8.8 gpg	2 ppm	0.11 gpg
> 682 to < 2050	150 ppm	8.8 gpg	2 ppm	0.11 gpg	2 ppm	0.11 gpg
> 2050	2 ppm	0.11 gpg	2 ppm	0.11 gpg	2 ppm	0.11 gpg

ppm - parts per million
gpg - grains per gallon

Note: The pH value of the heating water should be between 6.5 and 9.5

System Design Considerations *(continued)***System layout**

- The max. boiler water temperature for space heating and DHW production is 180°F (82°C) for models B2TB 19 to 125. To minimize distribution losses, Viessmann recommends that the heating and domestic hot water systems be based on a maximum boiler supply temperature of 158°F (70°C).
- Due to the low return temperatures required for gas condensing, no mixing valves should be used in the heating circuit whenever possible. If mixing valves are required, e.g. for multi-circuit systems or underfloor heating systems, only 3-way mixing valves must be used.
Do not use 4-way mixing valves with condensing boilers.

Underfloor heating systems

For underfloor heating systems Viessmann recommends the use of plastic tubing with an oxygen diffusion barrier in order to prevent the diffusion of oxygen through tubing. If plastic tubing without an oxygen diffusion barrier is used in underfloor heating systems, Viessmann recommends that such systems be separated from the boiler with a heat exchanger.

Underfloor heating systems and heating circuits containing a very large volume of water must be connected to the boiler via a 3-way mixing valve; please refer to the applicable installation example in this manual.

Oxygen diffusion barrier underfloor tubing

The boiler warranty does not cover leaks resulting from corrosion caused by the use of underfloor plastic tubing without an oxygen diffusion barrier. Such systems must have the non-oxygen diffusion barrier tubing separated from the boiler with a heat exchanger. Viessmann recommends the use of underfloor plastic tubing with an oxygen diffusion barrier.

Warranty

Our warranty does not cover damages resulting from the following:

- installation or service by unqualified and unlicensed personnel.
- attempting to perform any repair work on the boiler other than that mentioned in the boiler literature.
- tampering with or attempting, without Viessmann permission, to readjust the factory settings of the;
 - combination gas valve
 - combustion air opening of the burner blower
- leaks resulting from corrosion caused by the use of underfloor plastic tubing without an oxygen diffusion barrier. For detailed warranty information, please read warranty sheet supplied with product.

