

Installation,  
Operation, and  
Maintenance Manual

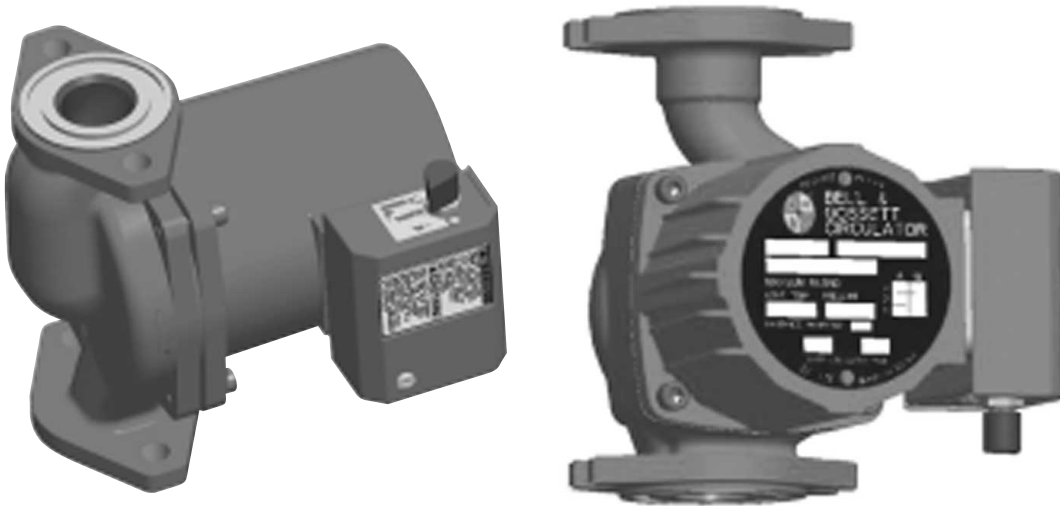

---

# NRF™ -25,36,45/NBF™ -25,36, and 45 Circulator

---

# Table of Contents

<b>Introduction and Safety</b> .....	2
Introduction.....	2
Requesting other information.....	2
Safety.....	2
Safety terminology and symbols.....	3
User safety.....	3
Environmental safety.....	5
Product warranty.....	5
<b>Transportation and Storage</b> .....	7
Inspect the delivery.....	7
Inspect the package.....	7
Inspect the unit.....	7
Pump storage requirements.....	7
<b>Product Description</b> .....	8
General description.....	8
Operational specifications.....	8
<b>Installation</b> .....	9
Pump location guidelines.....	9
Pump orientation.....	9
Change the conduit position.....	9
Install suction and discharge flange connectors on the pipe ends.....	10
Connect the wiring.....	10
Wiring diagram.....	11
Install a check valve.....	12
<b>Commissioning, Startup, Operation, and Shutdown</b> .....	13
Pump operation precautions.....	13
Prepare the system.....	13
Start the pump.....	13
Select the speed.....	13
Performance characteristic curve.....	14
<b>Maintenance</b> .....	16
Periodic inspection.....	16
Remove the pump from an existing system.....	16
<b>Troubleshooting</b> .....	17
Pumping system troubleshooting.....	17

# Introduction and Safety

## Introduction

### Purpose of this manual

The purpose of this manual is to provide necessary information for:

- Installation
- Operation
- Maintenance



---

#### CAUTION:

Read this manual carefully before installing and using the product. Improper use of the product can cause personal injury and damage to property, and may void the warranty.

---

---

#### NOTICE:

Save this manual for future reference, and keep it readily available at the location of the unit.

---

### Requesting other information

Special versions can be supplied with supplementary instruction leaflets. See the sales contract for any modifications or special version characteristics. For instructions, situations, or events that are not considered in this manual or in the sales documents, please contact the nearest Xylem representative.

Always specify the exact product type and identification code when requesting technical information or spare parts.

## Safety



---

#### WARNING:

- The operator must be aware of safety precautions to prevent physical injury.
  - Any pressure-containing device can explode, rupture, or discharge its contents if it is over-pressurized. Take all necessary measures to avoid over-pressurization.
  - Operating, installing, or maintaining the unit in any way that is not covered in this manual could cause death, serious personal injury, or damage to the equipment. This includes any modification to the equipment or use of parts not provided by Xylem. If there is a question regarding the intended use of the equipment, please contact an Xylem representative before proceeding.
  - This manual clearly identifies accepted methods for disassembling units. These methods must be adhered to. Trapped liquid can rapidly expand and result in a violent explosion and injury. Never apply heat to impellers, propellers, or their retaining devices to aid in their removal.
  - Do not change the service application without the approval of an authorized Xylem representative.
- 



---

#### CAUTION:

You must observe the instructions contained in this manual. Failure to do so could result in physical injury, damage, or delays.

---



## Safety terminology and symbols

### About safety messages

It is extremely important that you read, understand, and follow the safety messages and regulations carefully before handling the product. They are published to help prevent these hazards:

- Personal accidents and health problems
- Damage to the product
- Product malfunction

### Hazard levels

Hazard level	Indication
 <p><b>DANGER:</b></p>	A hazardous situation which, if not avoided, will result in death or serious injury
 <p><b>WARNING:</b></p>	A hazardous situation which, if not avoided, could result in death or serious injury
 <p><b>CAUTION:</b></p>	A hazardous situation which, if not avoided, could result in minor or moderate injury
<p><b>NOTICE:</b></p>	<ul style="list-style-type: none"> <li>• A potential situation which, if not avoided, could result in undesirable conditions</li> <li>• A practice not related to personal injury</li> </ul>

### Hazard categories

Hazard categories can either fall under hazard levels or let specific symbols replace the ordinary hazard level symbols.

Electrical hazards are indicated by the following specific symbol:



**Electrical Hazard:**

These are examples of other categories that can occur. They fall under the ordinary hazard levels and may use complementing symbols:

- Crush hazard
- Cutting hazard
- Arc flash hazard

## User safety

### General safety rules

These safety rules apply:

- Always keep the work area clean.
- Pay attention to the risks presented by gas and vapors in the work area.

- Avoid all electrical dangers. Pay attention to the risks of electric shock or arc flash hazards.
- Always bear in mind the risk of drowning, electrical accidents, and burn injuries.

### Safety equipment

Use safety equipment according to the company regulations. Use this safety equipment within the work area:

- Hard hat
- Safety goggles, preferably with side shields
- Protective shoes
- Protective gloves
- Gas mask
- Hearing protection
- First-aid kit
- Safety devices

---

**NOTICE:**

Never operate a unit unless safety devices are installed. Also see specific information about safety devices in other chapters of this manual.

---

### Electrical connections

Electrical connections must be made by certified electricians in compliance with all international, national, state, and local regulations. For more information about requirements, see sections dealing specifically with electrical connections.

### Precautions before work

Observe these safety precautions before you work with the product or are in connection with the product:

- Provide a suitable barrier around the work area, for example, a guard rail.
- Make sure that all safety guards are in place and secure.
- Make sure that you have a clear path of retreat.
- Make sure that the product cannot roll or fall over and injure people or damage property.
- Make sure that the lifting equipment is in good condition.
- Use a lifting harness, a safety line, and a breathing device as required.
- Allow all system and pump components to cool before you handle them.
- Make sure that the product has been thoroughly cleaned.
- Disconnect and lock out power before you service the pump.
- Check the explosion risk before you weld or use electric hand tools.

### Wash the skin and eyes

Follow these procedures for chemicals or hazardous fluids that have come into contact with your eyes or your skin:

Condition	Action
Chemicals or hazardous fluids in eyes	<ol style="list-style-type: none"><li>1. Hold your eyelids apart forcibly with your fingers.</li><li>2. Rinse the eyes with eyewash or running water for at least 15 minutes.</li><li>3. Seek medical attention.</li></ol>

Condition	Action
Chemicals or hazardous fluids on skin	<ol style="list-style-type: none"> <li>1. Remove contaminated clothing.</li> <li>2. Wash the skin with soap and water for at least 1 minute.</li> <li>3. Seek medical attention, if necessary.</li> </ol>

## Environmental safety

### The work area

Always keep the station clean to avoid and/or discover emissions.

### Waste and emissions regulations

Observe these safety regulations regarding waste and emissions:

- Appropriately dispose of all waste.
- Handle and dispose of the processed liquid in compliance with applicable environmental regulations.
- Clean up all spills in accordance with safety and environmental procedures.
- Report all environmental emissions to the appropriate authorities.



#### **WARNING:**

Do NOT send the product to the Xylem manufacturer if it has been contaminated by any nuclear radiation. Inform Xylem so that accurate actions can take place.

### Electrical installation

For electrical installation recycling requirements, consult your local electric utility.

### Recycling guidelines

Always follow local laws and regulations regarding recycling.

## Product warranty

### Coverage

Xylem undertakes to remedy defects in products from Xylem under these conditions:

- The faults are due to defects in design, materials, or workmanship.
- The faults are reported to an local sales and service representative within the warranty period.
- The product is used only under the conditions described in this manual.
- The monitoring equipment incorporated in the product is correctly connected and in use.
- All service and repair work is done by Xylem authorized personnel.
- Genuine Xylem parts are used.
- Only Ex-approved spare parts and accessories authorized by an EX-approved Xylem representative are used in Ex-approved products.

### Limitations

The warranty does not cover defects caused by these situations:

- Deficient maintenance
- Improper installation
- Modifications or changes to the product and installation made without consulting an Xylem authorized representative
- Incorrectly executed repair work
- Normal wear and tear

Xylem assumes no liability for these situations:

- Bodily injuries
- Material damages
- Economic losses

#### **Warranty claim**

Xylem products are high-quality products with expected reliable operation and long life. However, should the need arise for a warranty claim, then contact your local sales and service representative.

# Transportation and Storage

## Inspect the delivery

### Inspect the package

1. Inspect the package for damaged or missing items upon delivery.
2. Note any damaged or missing items on the receipt and freight bill.
3. File a claim with the shipping company if anything is out of order.  
If the product has been picked up at a distributor, make a claim directly to the distributor.

### Inspect the unit

1. Remove packing materials from the product.  
Dispose of all packing materials in accordance with local regulations.
2. Inspect the product to determine if any parts have been damaged or are missing.
3. If applicable, unfasten the product by removing any screws, bolts, or straps.  
For your personal safety, be careful when you handle nails and straps.
4. Contact your sales representative if anything is out of order.

## Pump storage requirements

Storage requirements depend on the amount of time that you store the unit. The normal packaging is designed only to protect the unit during shipping.

Length of time in storage	Storage requirements
Upon receipt/short-term (less than six months)	<ul style="list-style-type: none"> <li>• Store in a covered and dry location.</li> </ul>
Long-term (more than six months)	<ul style="list-style-type: none"> <li>• Store in a covered and dry location.</li> <li>• Store the unit free from heat, dirt, and vibrations.</li> </ul>



# Product Description

## General description

The NRF/NBF circulator pump has these features:

- System liquid lubricated bearings
- Non-overloading permanent split capacitor motor with thermal or impedance protection
- Quiet operation
- Nonsubmersible

## Pump application

---



### WARNING:

California Proposition 65 warning! This product contains chemicals known to the state of California to cause cancer and birth defects or other reproductive harm.

---

You can use this pump for these types of applications:

- Water circulating applications in hydronic and solar systems.
- Indoor use only

Do not use in swimming pools and marine areas.

Xylem recommends that you use bronze or stainless steel booster pumps for pumping potable water. For other applications, contact your local Xylem representative.

## Operational specifications

These pumps are designed to pump liquids compatible with their iron or bronze body constructions.

### Operational Limits

Parameter	Value
Maximum operating pressure	150 PSI (10 bars)
Maximum operating temperature	225°F (107°C)

### Electrical Rating

115V, 60Hz, 1Ø; 230V, 60Hz, 1Ø (single phase power)

# Installation

## Pump location guidelines

Guideline	Explanation/comment
Make sure that the space around the pump is sufficient.	This facilitates ventilation, inspection, maintenance, and service. Xylem recommends that the service valves on the suction and discharge of all circulators are installed so they can be serviced or replaced without draining the system.

## Pump orientation

You can install this pump to discharge up, down, left, or right. However, make sure that you install the pump according to these pump orientation guidelines:

- Only install the pump with the motor shaft horizontal.
- The arrow on the pump body must point in the direction of the flow.
- You must position the conduit box on the top or to the side of the motor housing. If you need to change the position of the conduit box, change it before you start the installation. If the pump is already installed, see [Remove the pump from an existing system](#) (page 16) before proceeding.

## Change the conduit position



### CAUTION:

Burn or projectile hazard. Make sure the power is turned off before placing anything inside the discharge opening to move the impeller.

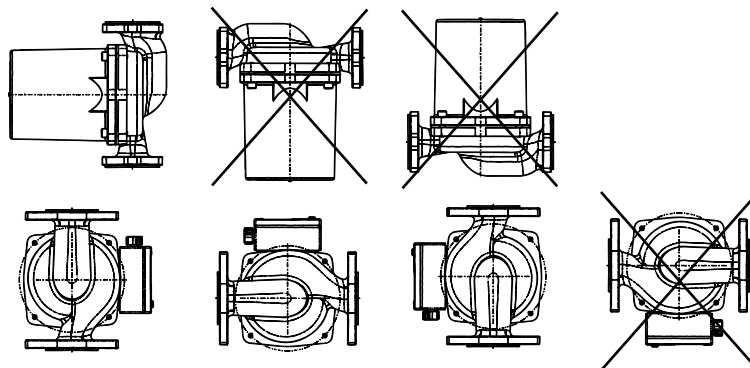

Figure 1: Conduit box position

1. While supporting the motor assembly, use a 3/16 wrench in order to remove the four 1/4-20 Allen screws.
2. Remove the motor assembly from the pump body and rotate it to the desired position.
3. Replace the Allen screws and tighten them evenly in a diagonal method to 60 in-lbs.
4. Check to see that the impeller turns freely. Insert your finger in the discharge port of the pump body until you can feel the impeller and rotate it with your fingertip.

The arrow on the pump body points in the direction of the discharge. If the impeller does not turn easily, repeat the disassembly/ reassembly process.

## Install suction and discharge flange connectors on the pipe ends

---



**WARNING:**

- Burn hazard. Make sure that each flange gasket remains seated in the flange groove during and after installation.
  - Burn hazard. Do NOT re-use old gaskets. When disassembling a gasketed joint, always use a new gasket upon reassembly.
- 

1. Use pipe hangers near the pump in order to support the suction and discharge piping. This minimizes pipe strain on the pump.
  2. Install the flange gaskets between the pump body flanges and the suction and discharge pipe flanges.  
Use a 7/16 in. x 1-1/2 in. capscrew and a matching nut in order to connect the pump to the flanges. The use of PTFE tape sealer or a high quality thread sealant is recommended.
- 



**CAUTION:**

Burn hazard. The use of PTFE impregnated pipe and PTFE tape on pipe threads provides lubricity which can lead to overtightening and breaks. Do not overtighten.

---

3. Line up the vertical and horizontal piping so that the bolt holes in the pump flanges match the bolt-holes in the pipe flanges.
- 

**NOTICE:**

Do not attempt to spring the suction or discharge lines in position. This may result in unwanted stress in the pump body, flange connections and piping.

---

The code for Pressure Piping (ANSI B31.1) lists many types of supports available for various applications.

4. Evenly torque the suction and discharge flange bolts to 115 in-lbs (12 Nm).
- 



**WARNING:**

Burn hazard. Make sure that the flange bolts or ring nuts have been properly tightened and that the solder connections do not leak.

---

## Connect the wiring



**WARNING:**

Disconnect and lock out electrical power before installing or servicing the pump.

---



**Electrical Hazard:**

Make sure that all connections are secure and the conduit box cover is closed before you connect the electrical power.

---

**CAUTION:**

Make sure that all wiring is rated to withstand at least 194°F (90°C).

1. Remove the screws that secure the conduit box cover.
2. Lift off the cover.
3. Attach the appropriately sized connector to the hole in the side of the conduit box.
4. Wire the motor to a single phase power source that matches the electrical rating on the pump nameplate. Use a minimum of 14 AWG copper electrical wire in order to accomplish this.

Refer to your local code for wiring restrictions. Use the size of electrical wire as dictated by local code.

5. Connect the earth (ground) wire to the inside of the conduit box with one of the green screws provided inside the box.

**Electrical Hazard:**

Make sure that the equipment is properly grounded. Use a grounded metal conduit, or ground the pump back to the service using a correctly sized copper conductor. Connect the ground wire to the green grounding screw in the wiring compartment.

The circulators are thermally protected by impedance or on-winding thermal protectors and do not require external overload protection.

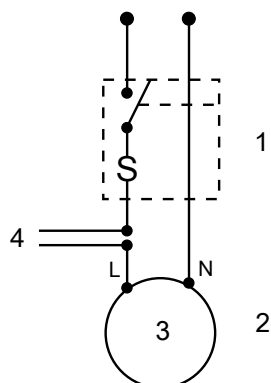
**Wiring diagram**

1. Fusible disconnect or circuit breaker by others
2. Pump motor thermally protected
3. Pump motor
4. To remote control, if required

Figure 2: Typical wiring installation schematic (1Ø power source)

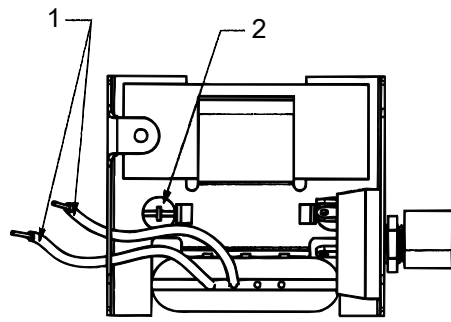

1. Line lead
2. Green ground screw

Figure 3: Conduit box wiring detail

## Install a check valve

The NRF/NBF-25 pump discharge nozzle is machined to accept check valve P/N P86596.

1. Insert the O-ring end of the check valve into the discharge port of the pump body.
2. Hand press the check valve body into place until it snaps into position.

# Commissioning, Startup, Operation, and Shutdown

## Pump operation precautions



---

### WARNING:

- Do NOT exceed the maximum working pressure of the pump. This information is listed on the nameplate of the pump.
  - The heating of water and other fluids causes volumetric expansion. The associated forces can cause the failure of system components and the release of high-temperature fluids. In order to prevent this, install properly sized and located compression tanks and pressure-relief valves. Failure to follow these instructions can result in serious personal injury or death, or property damage.
  - Make sure that all components are properly guarded or insulated when operating at extremely high or low temperatures.
  - Electrical connections must be made by certified electricians in compliance with all international, national, state, and local rules.
- 



---

### Electrical Hazard:

Do NOT install this pump in swimming pools or marine areas. Failure to follow these instructions could result in serious personal injury, death and/or property damage.

---

## Prepare the system

1. Clean and drain closed heating and cooling systems.
2. Refill the system with clean water.  
The system fluid pH must be maintained between 7 and 9.

## Start the pump



---

### WARNING:

Pressurize the pump body slowly while you check for leaks at all gasketed joints and solder connections.

---

Do not start pump until you fill and vent the system.

1. Vent air from the system by means of an air vent located at a high point in the system. The system must be completely vented prior to pump operation.
2. Make sure the pump is filled with clean water.

Do not run the pump dry. Pump operation without water circulation can result in pump and motor damage.

## Select the speed

The pump can be run at different speeds to suit the required operating conditions.

Select the speed by adjusting the three-position switch on the side of the terminal box.

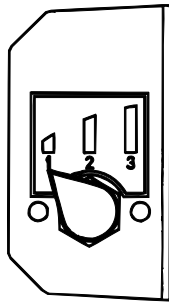

1. Minimum speed
2. Medium speed
3. Maximum speed

## Performance characteristic curve

Select the speed that best matches the design performance for the system or loop for which you are installing the pump.

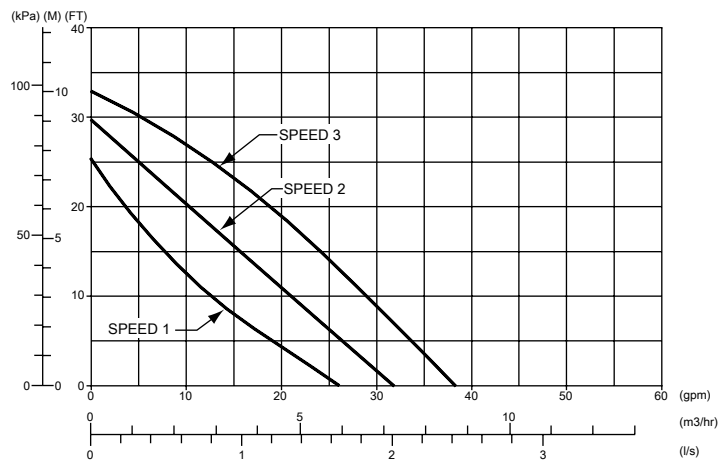

Figure 4: Centrifugal pump series NRF-36

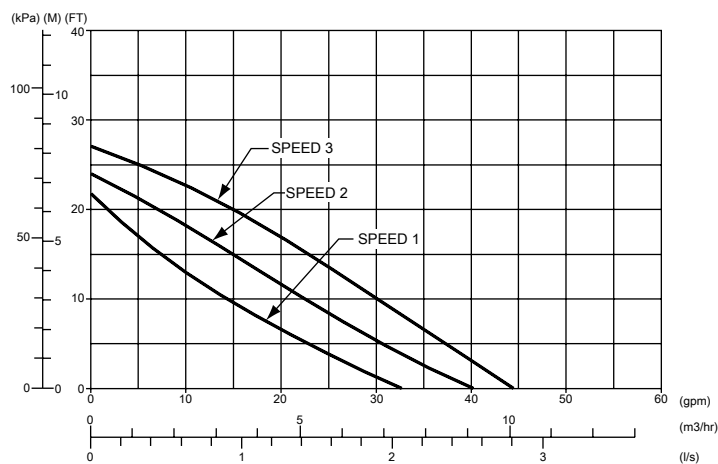

Figure 5: Centrifugal pump series NRF-45

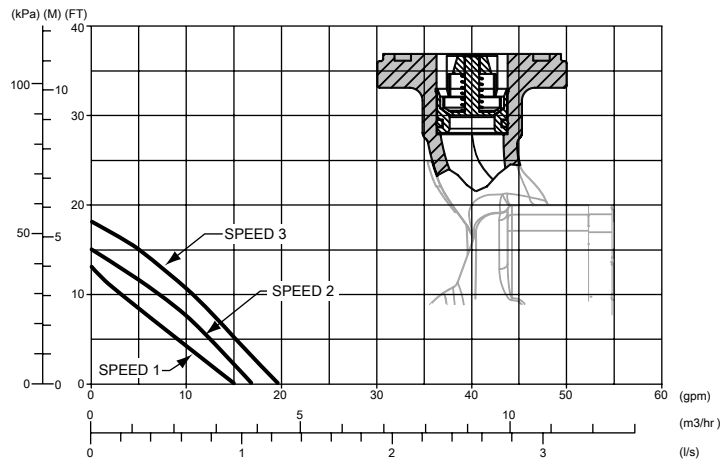

Figure 6: Centrifugal pump series NRF-25 with check valve

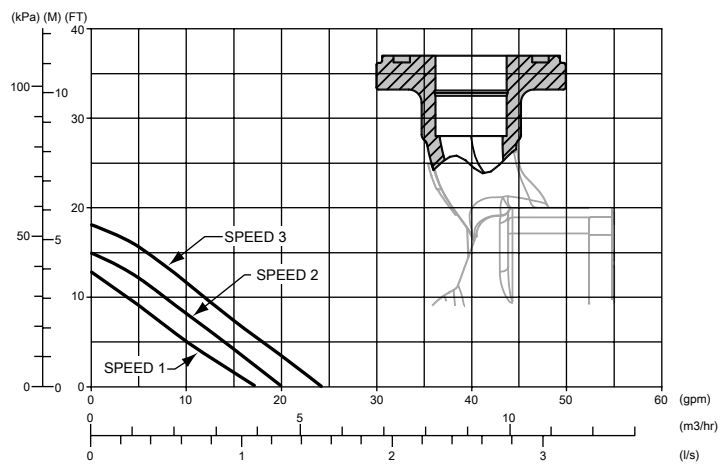

Figure 7: Centrifugal pump series NRF-25 without check valve



# Maintenance

## Periodic inspection

- It is recommended that periodic inspections be made to check for potential problems with the pump.
- If any leaks or evidence of leakage is present, repair or replace the unit.

## Remove the pump from an existing system



**WARNING:**

- Make sure that the pump is isolated from the system and that pressure is relieved before you disassemble the pump, remove plugs, open vent or drain valves, or disconnect the piping.
- Always disconnect and lock out power to the driver before you perform any installation or maintenance tasks. Failure to disconnect and lock out driver power will result in serious physical injury.
- Burn hazard. Do NOT re-use old gaskets. When disassembling a gasketed joint, always use a new gasket upon reassembly.

1. Close the valves on the suction and discharge sides of the pump.  
If no valves are installed, you might need to drain the system.
2. Drain the system:



**WARNING:**

Allow all system and pump components to cool before you handle them to prevent physical injury.

- a) Allow the water to cool to at least 100°F (38°C).
- b) Take precautions against water damage, and then open the drain valve.
- c) Leave the drain valve open until servicing is complete.



**Electrical Hazard:**

Make sure the electrical power is not present at the motor leads before continuing.

3. Loosen the screws on the conduit box and remove the cover.
4. Disconnect the electrical supply lines to the pump.
5. Relieve pressure in the pump body.



**WARNING:**

Pressurized device. Relieve any contained pressure in the pump body by loosening the flange bolts and shifting the pump assembly slightly to allow the pressurized water to escape.

6. Remove the flange nuts and bolts or loosen the union ring nuts. Then remove the pump from the piping

# Troubleshooting

## Pumping system troubleshooting

Symptom	Cause	Remedy
There is no circulation	Air-bound system	Vent the system
	The impeller or piping is clogged.	Locate and remove the obstruction.
	The system valve is closed.	Open
	The electrical circuit for the pump is broken.	Check all related low and line voltage circuits.
There is inadequate circulation.	Air-bound system	Vent the system.
	The impeller or piping is clogged.	Locate and remove the obstruction.
	The impeller is damaged.	Replace pump.
	The pump is too small.	Replace the pump if single speed. If three speed switch to higher setting.
	Partially air-bound pump	Vent the pump casing.
	Improper motor speed	Check the wiring and the voltage.
There is pump or system noise.	Entrained air	Vent the system.
	Pump cavitation	Lower the pump or raise pressure or relocate (see note below).
	Excessive water velocity	Install balancing cocks or parallel piping.
	Pipe vibration	Provide adequate pipe support.
There is premature failure of pump components.	Improper pump (size/type)	Replace
	Improper pump location	Relocate
	Excessive water treatment	Check the manufacturer's instructions.
	Pump operating close to or beyond the end point of curve.	Balance the system.
	Excessive piping load	Provide proper pipe support

Symptom	Cause	Remedy
There are seal failures within a 1-year period or less in a closed system.	Excessive dirt, sand and oxides	Clean the system.
	Excessive or improper water treatment	Check for proper water treatment recommendations from pump manufacturer.
	Pump Cavitation: 1. Improper selection 2. Compression tank location	<ol style="list-style-type: none"> <li>1. Check pump operation on its curve – overloading</li> <li>2. High head pump must have compression tank on suction side of pump.</li> </ol>
	Excessive temperatures	Check the type of seal and maximum operating temperature from the manufacturer.
	Pumps run without fluid	Pumps must be primed before operation.
There is seal pitting, oxygen corrosion, magnetic iron oxide.	Caused by wear and excessive amounts of free oxygen.	Check if system has a constant leak.
	Fresh water feeding carries oxygen into the system.	

**NOTICE:** Cavitation is identified by low rumbling or sharp rattling noises. This situation is created by the lack of available net positive suction head (NPSH). The pressure at some point in the pump falls below the vapor pressure of the water causing flashing and the formation of bubbles, which are carried into the volute where the higher pressure causes them to implode. This can eventually destroy the pump.

# Xylem |'zīləm|

- 1) The tissue in plants that brings water upward from the roots
- 2) A leading global water technology company

We're 12,500 people unified in a common purpose: creating innovative solutions to meet our world's water needs. Developing new technologies that will improve the way water is used, conserved, and re-used in the future is central to our work. We move, treat, analyze, and return water to the environment, and we help people use water efficiently, in their homes, buildings, factories and farms. In more than 150 countries, we have strong, long-standing relationships with customers who know us for our powerful combination of leading product brands and applications expertise, backed by a legacy of innovation.

For more information on how Xylem can help you, go to [xylem.com](http://xylem.com)



Xylem Inc.  
8200 N. Austin Avenue  
Morton Grove, IL 60053  
Tel. 1-847-966-3700  
Fax 1-847-965-8379  
[www.xylem.com/brands/bellgossett](http://www.xylem.com/brands/bellgossett)

Visit our Web site for the latest version of this document and more information

The original instruction is in English. All non-English instructions are translations of the original instruction.

© 2012 Xylem Inc.

Bell & Gossett is a trademark of Xylem Inc or one of its subsidiaries.