

Bosch BOVA 2.0 Split System Heat Pump

Condensing Units Up to 20.5 SEER

2-3-4-5 Ton Capacity

R410A



BOSCH

Installation Instructions



Table of Contents

1 Key to Symbols and Safety Instructions	4	13 Start Up	20
1.1 Key to Symbols	4	13.1 System Start Up	20
1.2 Safety	4		
2 Unit Location Considerations	6	14 System Charge Adjustment	21
2.1 Unit Dimensions	6	14.1 Charging: Weigh-In Method	21
2.2 Refrigerant Piping Limits	6	14.2 Subcooling Charging And Refrigerant Adjustment In Cooling (Above 55°F Outdoor Temp.)	21
2.3 Location Restrictions	7		
3 Unit Preparation	8	15 System Operation and Troubleshooting	24
3.1 Prepare the Unit for Installation	8	15.1 Control Logic Description	24
		15.2 Sensors (Thermistors/Pressure Transducer)	24
4 Setting the Unit	8	15.3 Pressure Equalizer Valve (PEV)	24
4.1 Pad Installation	8	15.4 Defrost Description	24
		15.5 Compressor Crankcase Heater Description	25
5 Refrigerant Line Considerations	9	15.6 Reversing Valve Operation	25
5.1 Refrigerant Line and Service Valve Connection Sizes	9	15.7 Protection Functions	25
5.2 Required Refrigerant Line Length	9	15.8 Fault Code Table	26
5.3 Refrigerant Line Insulation	9	15.9 Parameter Point Check Table	27
5.4 Reuse Existing Refrigerant Lines	9	15.10 Control Board Overviews	28
		15.11 Error Code Troubleshooting	30
6 Refrigerant Line Routing	10	15.12 Temperature and Resistance Relationship Tables (for Sensors)	36
6.1 Precautions	10	15.13 Temperature and Resistance Relationship Tables (for T5 & Tf Sensors)	37
7 Refrigerant Line Brazing	11	16 Wiring Diagram	39
7.1 Braze The Refrigerant Lines	11		
		17 Care and Maintenance	40
8 Refrigerant Line Leak Check	13	17.1 Cleaning Precautions	40
8.1 Check For Leaks	13	17.2 Maintenance – Pre-Season Inspection	40
9 Evacuation	13		
9.1 Evacuate the Refrigerant Lines and Indoor Coil	13		
10 Service Valves	14		
10.1 Open the Service Valves	14		
11 Electrical - Low Voltage	15		
11.1 Low Voltage Maximum Wire Length	15		
11.2 Low Voltage Hook-Up Diagrams	15		
11.3 Thermostat Wiring Diagrams	15		
12 Electrical - High Voltage	19		
12.1 High Voltage Power Supply	19		
12.2 High Voltage Disconnect Switch	19		
12.3 High Voltage Ground	19		

1 Key to Symbols and Safety Instructions

1.1 Key to Symbols

Warnings



Warnings in this document are identified by a warning triangle printed against a grey background. Keywords at the start of a warning indicate the type and seriousness of the ensuing risk if measures to prevent the risk are not taken.

The following keywords are defined and can be used in this document:

- ▶ **DANGER** indicates a hazardous situation which, if not avoided, will result in death or serious injury.
- ▶ **WARNING** indicates a hazardous situation which, if not avoided, could result in death or serious injury.
- ▶ **CAUTION** indicates a hazardous situation which, if not avoided, could result in minor to moderate injury.
- ▶ **NOTICE** is used to address practices not related to personal injury.

Important information



This symbol indicates important information where there is no risk to people or property.

1.2 Safety

Please read before proceeding



WARNING: ELECTRICAL HAZARD 380 VOLTS DC

- ▶ Failure to follow this warning could result in property damage, severe personal injury, or death.
- ▶ WAIT THREE (3) MINUTES after disconnecting power prior to touching electrical components as they may hold a dangerous charge of 380 VDC, then verify DC Voltage is less than 42VDC at inverter TEST POINTS P-N.

NOTICE:

- ▶ This document is customer property and is to remain with this unit. Please return to service information pack upon completion of work.
- ▶ These instructions do not cover all variations in systems or provide for every possible contingency to be met in connection with the installation.
- ▶ Should further information be desired or should particular problems arise which are not covered sufficiently for the purchaser's purposes, the matter should be referred to your installing dealer or local distributor.



The manufacturer recommends installing only approved matched indoor and outdoor systems. All of the manufacturer's split systems are AHRI rated only with TXV indoor systems. Some of the benefits of installing approved matched indoor and outdoor split systems are maximum efficiency, optimum performance and the best overall system reliability.



This document contains a wiring diagram and service information. This is customer property and is to remain with this unit. Please return to service information pack upon completion of work.



WARNING:

- ▶ This information is intended for use by individuals possessing adequate backgrounds of electrical and mechanical experience. Any attempt to repair a central air conditioning product may result in personal injury and/or property damage.

**WARNING: HAZARDOUS VOLTAGE**

- ▶ Failure to follow this warning could result in property damage, severe personal injury, or death.
- ▶ Disconnect all electric power, including remote disconnects before servicing. Follow proper lockout/tagout procedures to ensure the power cannot be inadvertently energized.

**CAUTION: GROUNDING REQUIRED**

- ▶ Failure to inspect or use proper service tools may result in equipment damage or personal injury. Reconnect all grounding devices. All parts of this product that are capable of conducting electrical current are grounded. If grounding wires, screws, straps, clips, nuts, or washers used to complete a path to ground are removed for service, they must be returned to their original position and properly fastened.

**WARNING: REFRIGERANT OIL**

- ▶ Any attempt to repair a central air conditioning product may result in property damage, severe personal injury, or death. These units use R-410A refrigerant which operates at 50 to 70% higher pressures than R-22. Use only R-410A approved service equipment. Refrigerant cylinders are painted a "Rose" color to indicate the type of refrigerant and may contain a "dip" tube to allow for charging of liquid refrigerant into the system. All R-410A systems with variable speed compressors use a POE oil (VG74 or equivalent) that readily absorbs moisture from the atmosphere. To limit this "hygroscopic" action, the system should remain sealed whenever possible. If a system has been open to the atmosphere for more than 4 hours, the compressor oil must be replaced. Never break a vacuum with air and always change the driers when opening the system for component replacement.

**WARNING: SERVICE VALVES**

- ▶ Failure to follow this warning will result in abrupt release of system charge and may result in personal injury and/or property damage. Extreme caution should be exercised when opening the Liquid Line Service valve. Turn valve stem counterclockwise only until the stem contacts the rolled edge.

**WARNING: BRAZING REQUIRED**

- ▶ Failure to inspect lines or use proper service tools may result in equipment damage or personal injury. If using existing refrigerant lines make certain that all joints are brazed, not soldered.

**WARNING: HOT SURFACE**

- ▶ May cause minor to severe burning. Failure to follow this Caution could result in property damage or personal injury. Do not touch top of compressor.

**WARNING: HIGH CURRENT LEAKAGE**

- ▶ Failure to follow this warning could result in property damage, severe personal injury, or death. Grounding is essential before connecting electrical supply.

**CAUTION: CONTAINS REFRIGERANT**

- ▶ Failure to follow proper procedures can result in personal illness or injury or severe equipment damage. System contains oil and refrigerant under high pressure. Recover refrigerant to relieve pressure before opening system.

**WARNING:**

- ▶ This product can expose you to chemicals including Lead and Lead components, which are known to the State of California to cause cancer and birth defects or other reproductive harm. For more information go to www.P65Warnings.ca.gov.

**CAUTION: INDOOR UNIT REQUIRED**

- ▶ The indoor units must be matched with TXV. The model of TXV can be changed according to the system capacity.

2 Unit Location Considerations

2.1 Unit Dimensions

Unit Dimensions	
Models	H x W x L (Inches)
BOVA-36	24-15/16 x 29-1/8 x 29-1/8
BOVA-60	33-3/16 x 29-1/8 x 29-1/8

Table 1

The unit's weight values are on the carton box.

When mounting the outdoor unit on a roof, be sure the roof will support the unit's weight. Properly selected isolation is recommended to prevent sound or vibration transmission to the building structure.

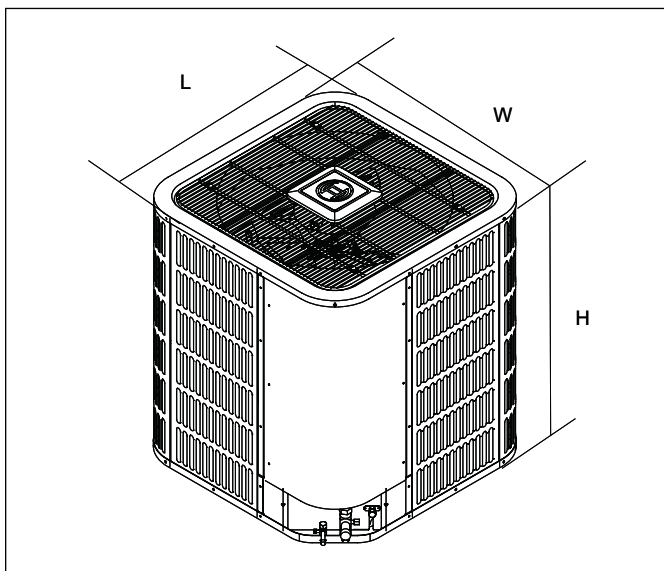

Figure 1

2.2 Refrigerant Piping Limits

System Capacity Model	Liquid Line Inch O.D.	Suction Line	Total Equivalent Length - Feet					
			25	50	75	100	125	150
2 Ton	3/8 *	3/4 Std.	25	50	45	40	30	25
		5/8 Opt.	25	50	45	40	30	25
3 Ton	3/8 *	3/4 Std.	25	50	50	50	35	25
		5/8 Opt.	25	50	50	50	35	25
4 Ton	3/8 *	7/8 Std.	25	50	50	40	30	25
		3/4 Opt.	25	50	50	40	30	25
5 Ton	3/8 *	7/8 Std.	25	50	50	40	30	25
		3/4 Opt.	25	50	50	40	30	25
		1 1/8 Opt.	25	40	N/A	N/A	N/A	N/A

Table 2

* Standard line size is recommended;
 N/A: Application not recommended;
 Refrigerant charge: refer to Sec. 14

- ▶ Maximum line equivalent length = 150 feet.
- ▶ Maximum vertical equivalent length = 50 feet.
- ▶ Use only the line diameters indicated in Table 2.
- ▶ If the suction linesets are greater than 50 feet, do not use a larger suction line than recommended.

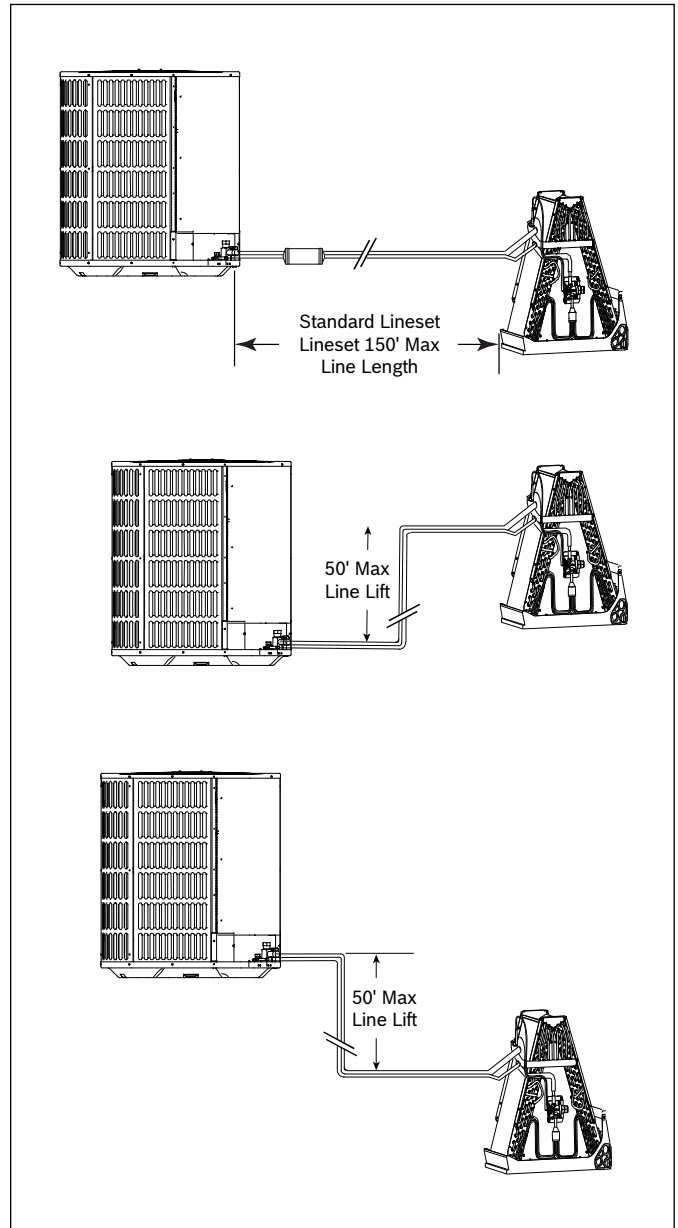

Figure 2

2.3 Location Restrictions

Ensure the top discharge area is unrestricted for at least 60 inches above the unit.
Do not locate outdoor unit near bedrooms since normal operational sounds may be objectionable.

Position unit to allow adequate space for unobstructed airflow, wiring, refrigerant lines, and serviceability.

Allow a minimum of 12 in. clearance on one side of control board access panel to a wall and a minimum of 24 in. on the adjacent side of control board access panel.

Maintain a distance of 24 in. between units.

Position unit where water, snow, or ice from roof or overhang cannot fall directly on unit.

See Fig. 3 and Fig. 4.

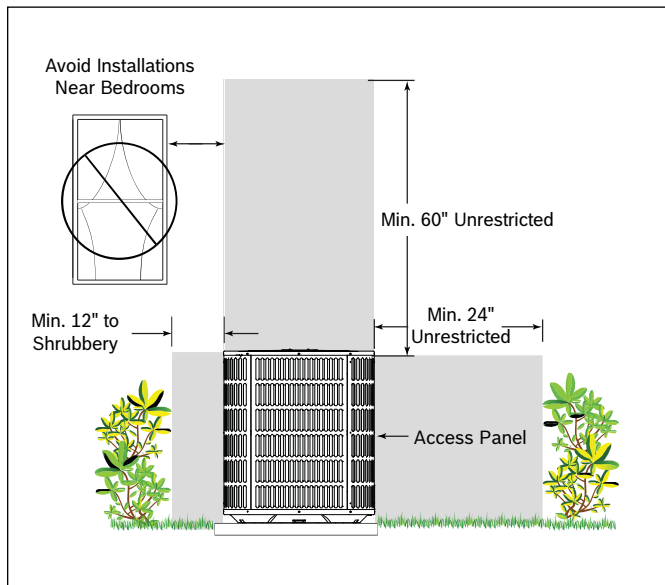

Figure 3

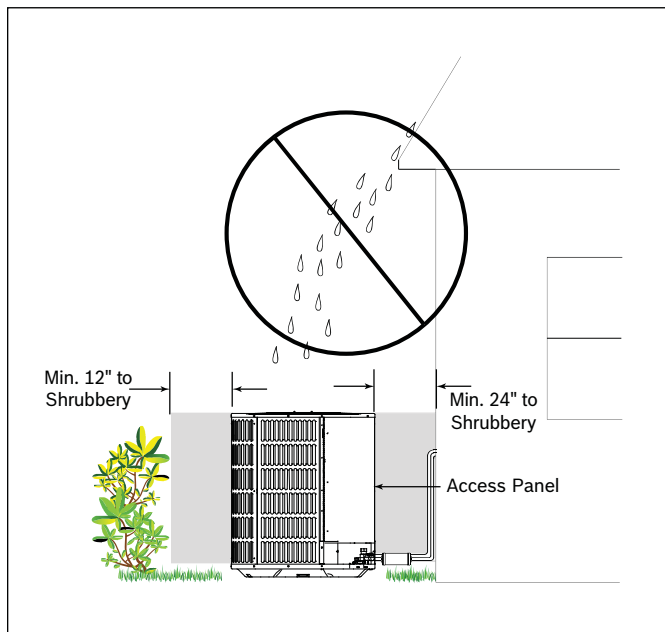

Figure 4

Cold climate considerations (heat pump only)



Precautions must be taken for units being installed in areas where snow accumulation and prolonged below-freezing temperatures occur.

- ▶ Units should be elevated 3-12 inches above the pad or rooftop, depending on local weather. This additional height will allow drainage of snow and ice melted during defrost cycle prior to its refreezing. Ensure that drain holes in unit base pan are not obstructed, which could prevent the drainage of defrost water (Fig. 5).
- ▶ If possible, avoid locations that are prone to snow drifts. If not possible, a snow drift barrier should be installed around the unit to prevent a build-up of snow on the sides of the unit.

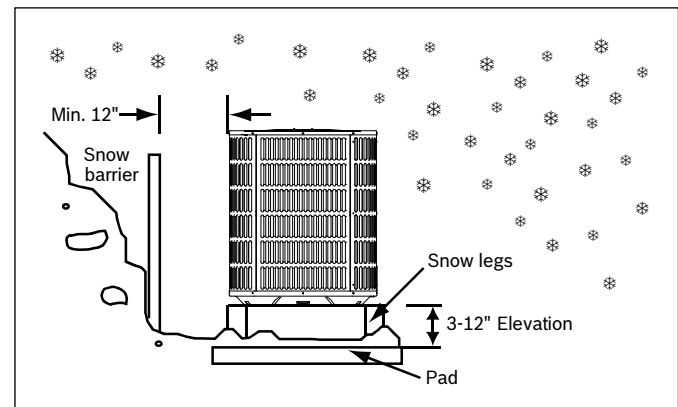

Figure 5

Corrosive Environment

Exposure to a corrosive environment may shorten the life of the equipment, corrode metal parts, and/or negatively affect unit performance. Corrosive elements include, but are not limited to: sodium chloride, sodium hydroxide, sodium sulfate, and other compounds commonly found in ocean water, sulfur, chlorine, fluorine, fertilizers, and various chemical contaminants from industry/manufacturing plants. If installed in areas which may be exposed to corrosive environments, special attention should be given to the equipment placement and maintenance.

- ▶ Lawn sprinklers/hoses/waste water should not spray directly on the unit cabinet for prolonged periods of time.
- ▶ In coastal areas: locate the unit on the side of the building away from the waterfront.
- ▶ Fencing or shrubbery may provide some shielding protection to the unit, however minimum unit clearances must still be maintained.
- ▶ Approximately every three months, wash the outdoor coil and any exposed cabinet surfaces.

3 Unit Preparation

3.1 Prepare the Unit for Installation

- ▶ Check for damage and report promptly to the carrier any damage found to the unit (Fig. 6).
- ▶ The charge port can be used to ensure the refrigerant charge has been retained during shipment.

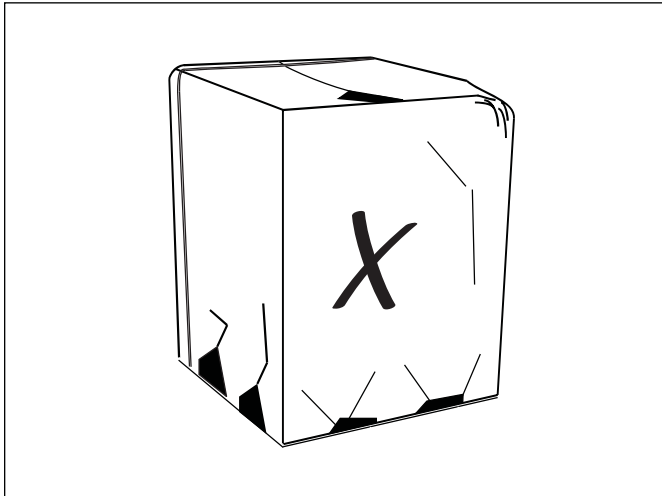

Figure 6

4 Setting the Unit

4.1 Pad Installation

When installing the unit on a support pad, such as a concrete slab, consider the following:

- ▶ The pad must be at least 1-2" larger than the unit on all sides.
- ▶ The pad must be separated from any structure.
- ▶ The pad must be level.
- ▶ The pad must be high enough above grade to allow for drainage.
- ▶ The pad location must comply with National, State, and local codes.



These instructions are intended to provide a method to tie-down system to cement slab as a securing procedure for high wind areas. Check local codes for tie-down methods and protocols.

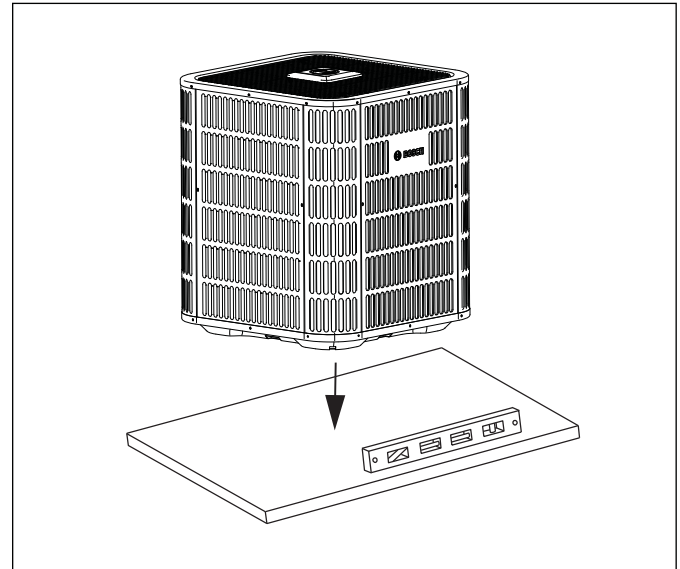

Figure 7

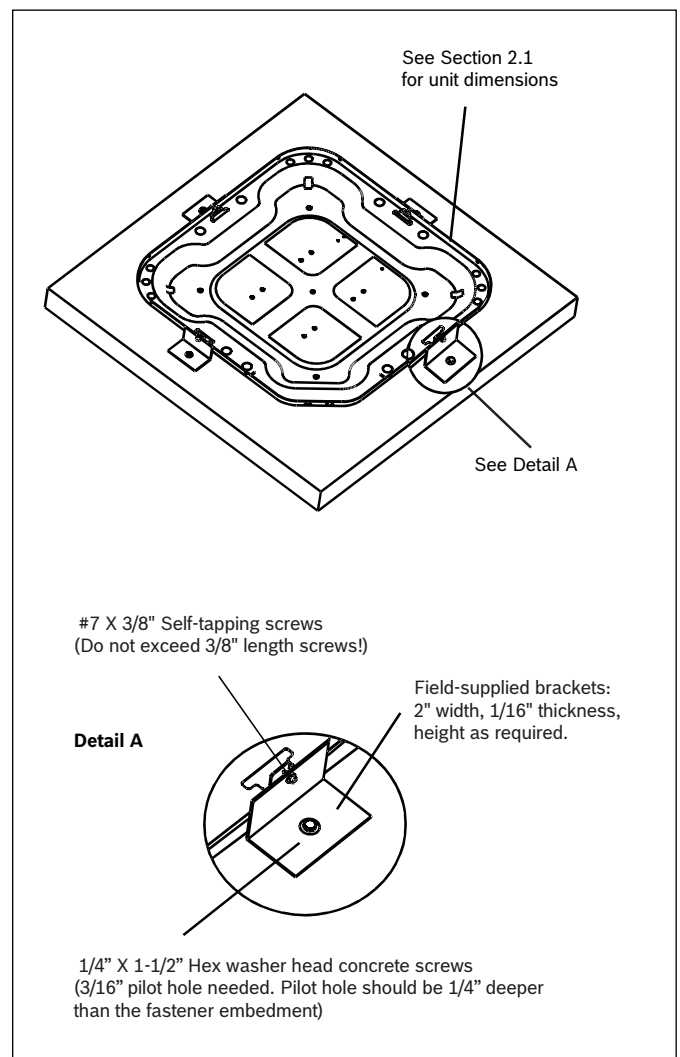

Figure 8

5 Refrigerant Line Considerations

5.1 Refrigerant Line and Service Valve Connection Sizes

Models	Suction Line	Liquid Line	Suction Line Connection	Liquid Line Connection
	Dimensions in inches			
BOVA-36	3/4	3/8	3/4	3/8
BOVA-60	7/8	3/8	7/8	3/8

Table 3

5.2 Required Refrigerant Line Length

Determine required line length (Fig. 9). Refer to Section 2.2.

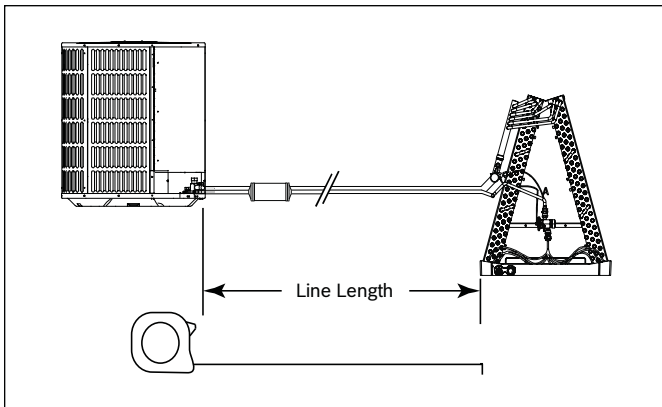

Figure 9

5.3 Refrigerant Line Insulation

i The Suction Line must always be insulated. DO NOT allow the Liquid Line and Suction Line to come in direct (metal to metal) contact.

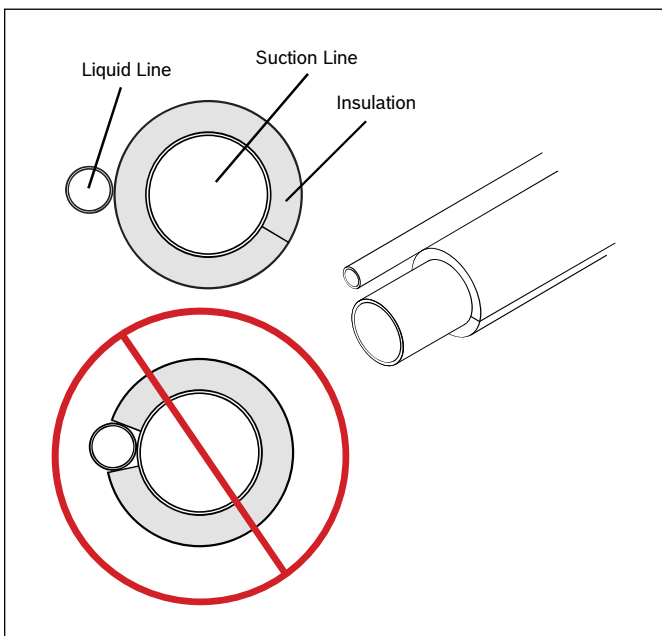

Figure 10

5.4 Reuse Existing Refrigerant Lines



CAUTION: MINOR TO MODERATE BURNS

- ▶ If using existing refrigerant lines, make certain that all joints are brazed, not soldered.

For retrofit applications, where the existing refrigerant lines will be used, the following precautions should be taken:

- ▶ Ensure that the refrigerant lines are the correct size. Refer to Section 2.2 and Table 2.
- ▶ Ensure that the refrigerant lines are free of leaks, acid, and oil.



The manufacturer recommends installing only approved matched indoor and outdoor systems. All of the manufacturer's split systems are AHRI rated only with TXV indoor systems. The benefits of installing approved matched indoor and outdoor split systems are maximum efficiency, optimum performance and the best overall system reliability.

6 Refrigerant Line Routing

6.1 Precautions



Take precautions to prevent noise within the building structure due to vibration transmission from the refrigerant lines. For example:

- ▶ When the refrigerant lines have to be fastened to floor joists or other framing in a structure, use isolation type hangers.
- ▶ Isolation hangers should also be used when refrigerant lines are run in stud spaces or enclosed ceilings.
- ▶ Where the refrigerant lines run through a wall or sill, they should be insulated and isolated.
- ▶ Isolate the lines from all ductwork.
- ▶ Minimize the number of 90° turns.



Comply with National, State, and local codes when isolating linesets from joists, rafters, walls, or other structural elements.

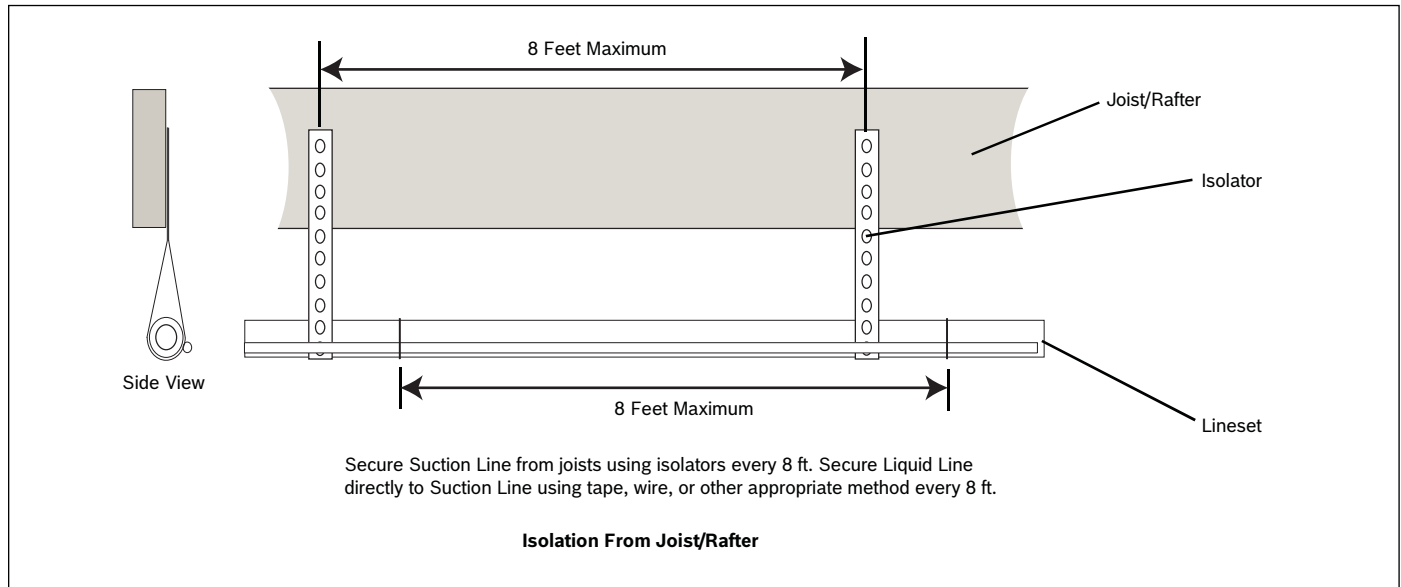

Figure 11

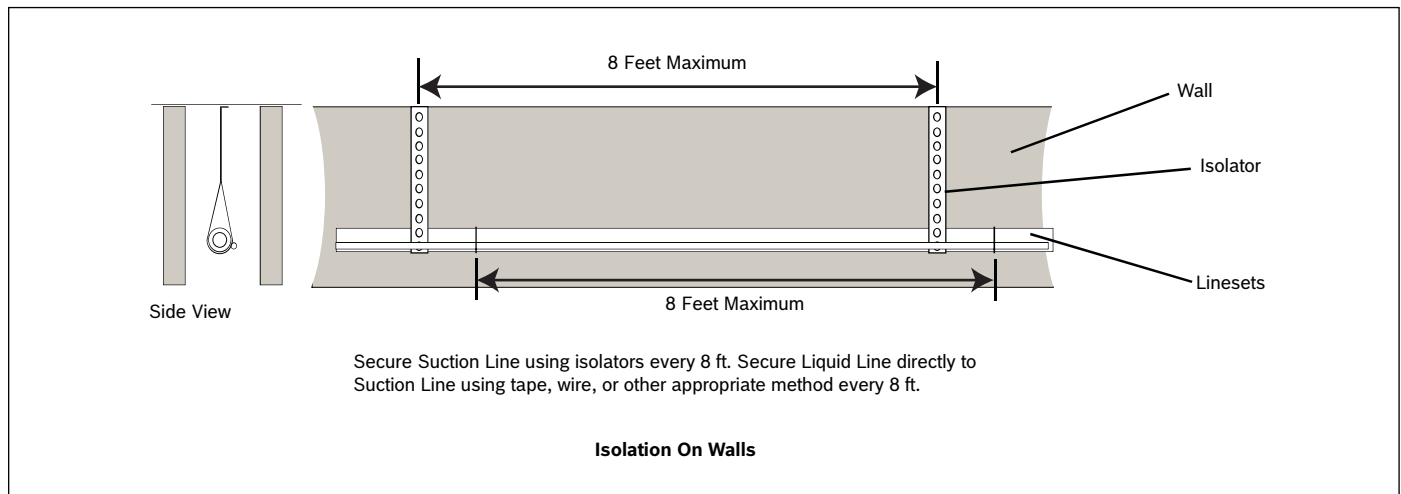

Figure 12

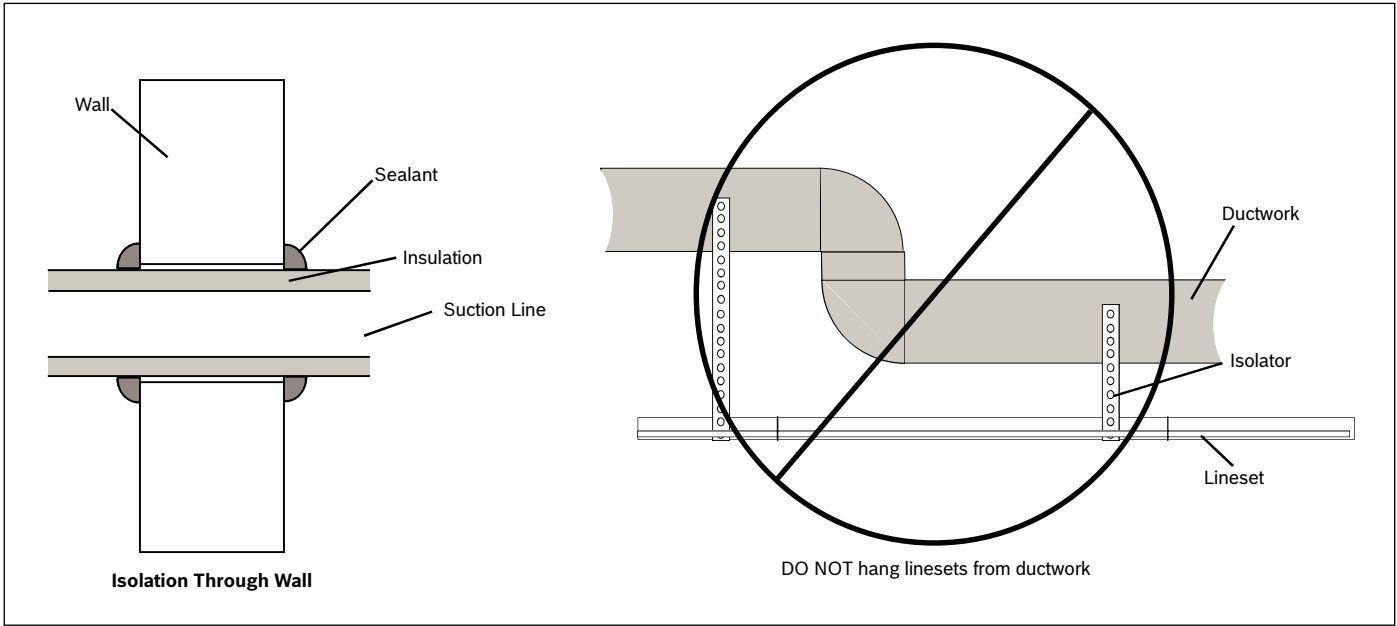

Figure 13

7 Refrigerant Line Brazing

7.1 Braze The Refrigerant Lines

1. Remove caps or plugs. Use a deburring tool to deburr the pipe ends. Clean both internal and external surfaces of the tubing using an emery cloth.

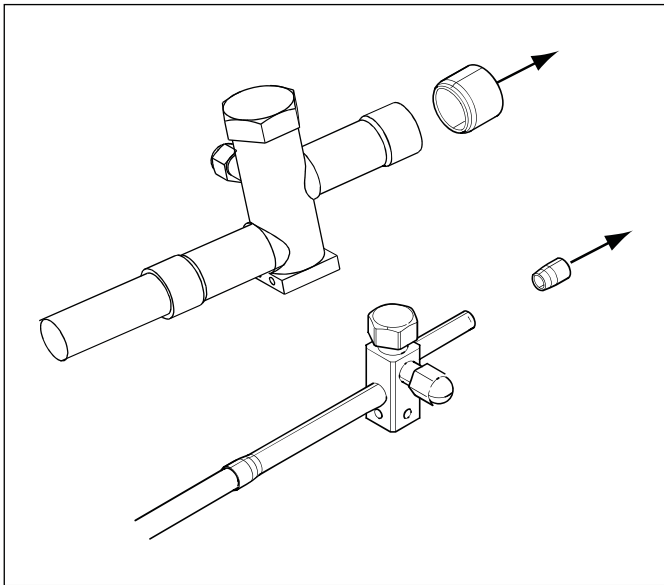

Figure 14

- Remove the pressure tap cap from both service valves.

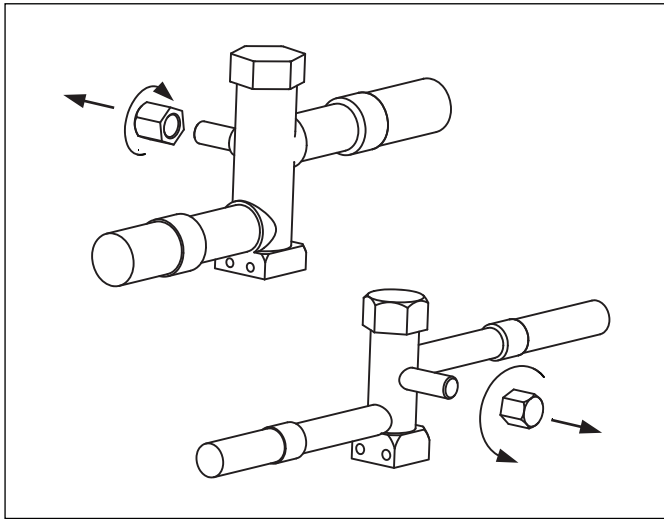

Figure 15

- Purge the refrigerant lines and indoor coil with dry nitrogen.

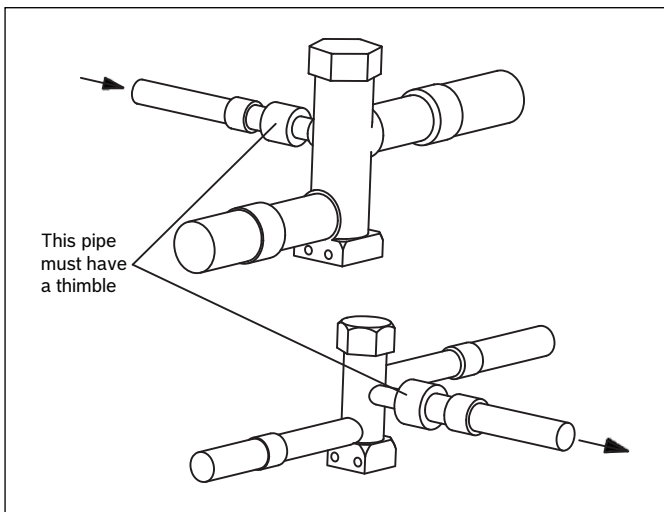

Figure 16

- Wrap a wet rag around the valve body to avoid heat damage and continue the dry nitrogen purge (Fig. 17).

Braze the refrigerant lines to the service valves.

Braze the filter drier to the Liquid Line.



All units come standard with a bi-flow filter drier. Braze the filter drier to the liquid line, using caution not to push the refrigerant line too hard past the stop within the filter drier (this could damage the drier).

Continue the dry nitrogen purge. Do not remove the wet rag until all brazing is completed.



Remove the wet rag before stopping the dry nitrogen purge.

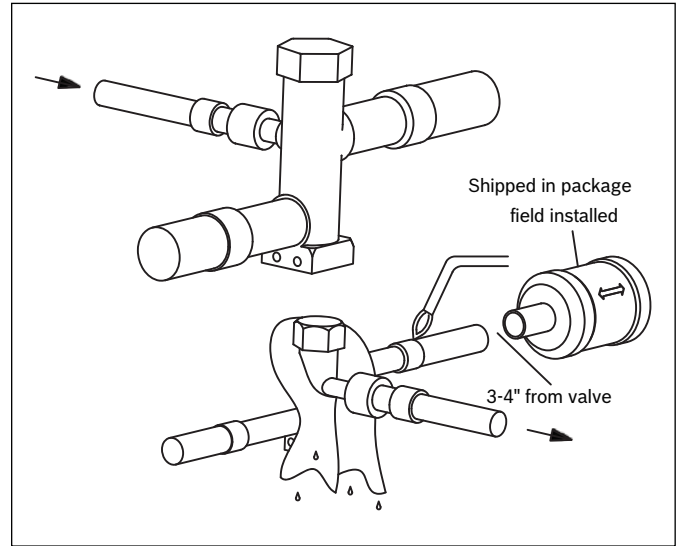

Figure 17

- Replace the pressure tap caps after the service valves have cooled.

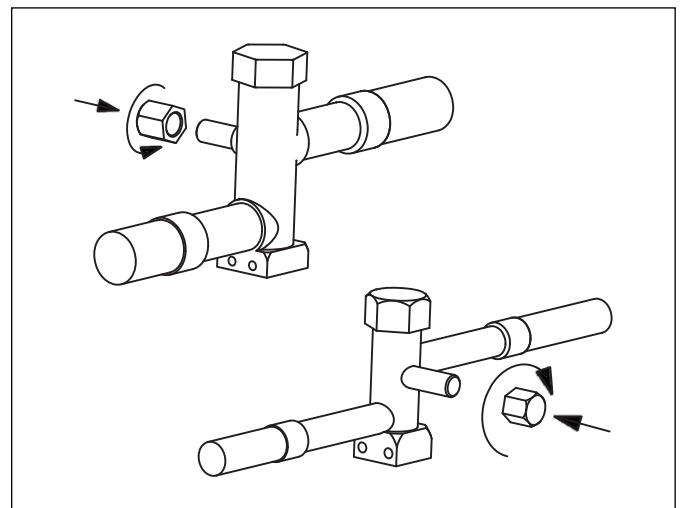

Figure 18

8 Refrigerant Line Leak Check

8.1 Check For Leaks

1. Pressurize the refrigerant lines and evaporator coil to 150 PSIG using dry nitrogen.

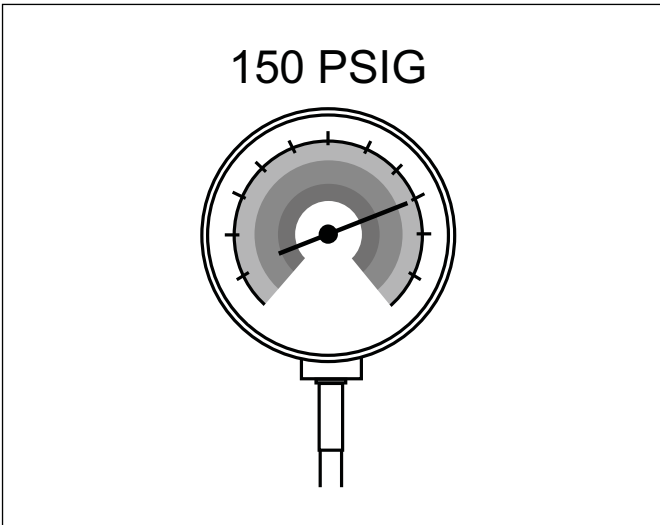

Figure 19

2. Check for leaks by using a soapy solution or bubbles at each brazed location.

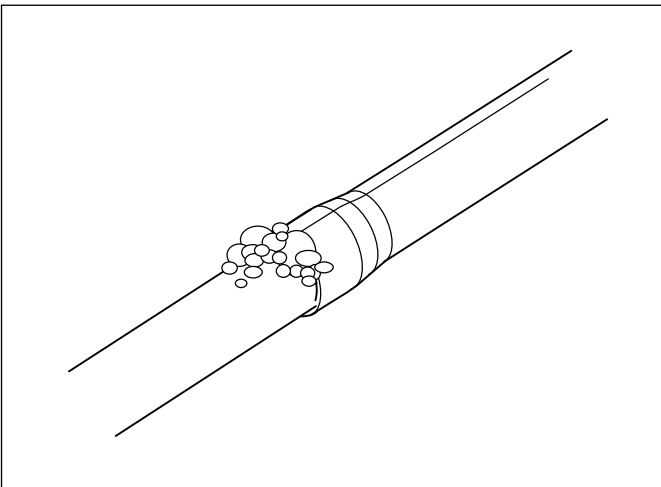

Figure 20

9 Evacuation

9.1 Evacuate the Refrigerant Lines and Indoor Coil



Do not open the service valves until the refrigerant lines and indoor coil leak check and evacuation are complete.

1. Evacuate until the micron gauge reads no higher than 350 microns, then close the valve to the vacuum pump.

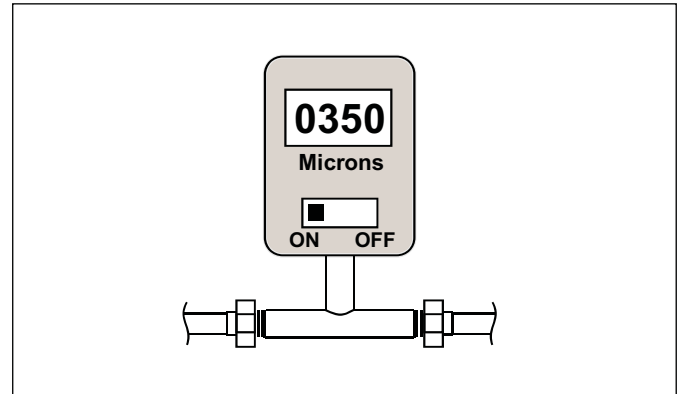

Figure 21

2. Observe the micron gauge. Evacuation is complete if the micron gauge does not rise above 500 microns in one (1) minute.

Once evacuation is complete, turn off the vacuum pump and micron gauge, and close the valves on the manifold gauge set.



Figure 22

10 Service Valves

10.1 Open the Service Valves



WARNING: MODERATE TO SEVERE BURNS

- ▶ Extreme caution should be exercised when opening the Liquid Line Service Valve. Turn counterclockwise until the valve stem just touches the rolled edge. No torque is required. Failure to follow this warning will result in abrupt release of system charge and may result in personal injury and /or property damage.



Leak check and evacuation must be completed before opening the service valves. The brazed lineset valves should be used for leak checking and vacuuming. Using the separate suction port for this process will result in loss of charge.



The Suction Service Valve must be opened first BEFORE opening the Liquid Service Valve.

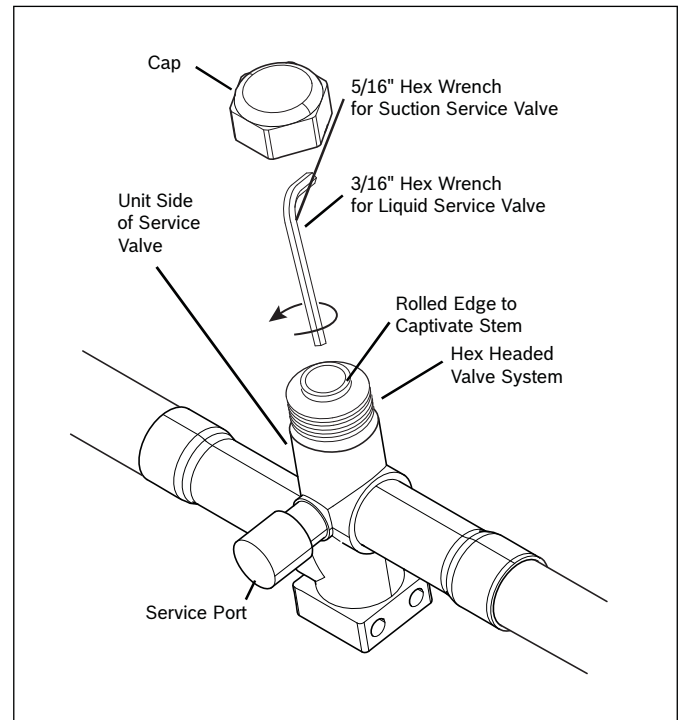

Figure 23

1. Remove Service Valve Cap (Fig. 23).
2. Fully insert hex wrench into the stem and back out counterclockwise until valve stem just touches the rolled edge (approximately five (5) turns.)
3. Replace the Valve Stem Cap to prevent leaks. Tighten finger tight plus an additional 1/6 turn.
4. Repeat STEPS 1 - 3 for Liquid Service Valve.

11 Electrical - Low Voltage

11.1 Low Voltage Maximum Wire Length

Table 4 defines the maximum total length of low voltage wiring from the outdoor unit, to the indoor unit, and to the thermostat.

24 Volts - Wire size	Max. Wire Length
18 AWG	150 Ft.
16 AWG	225 Ft.
14 AWG	300 Ft.

Table 4

11.2 Low Voltage Hook-Up Diagrams

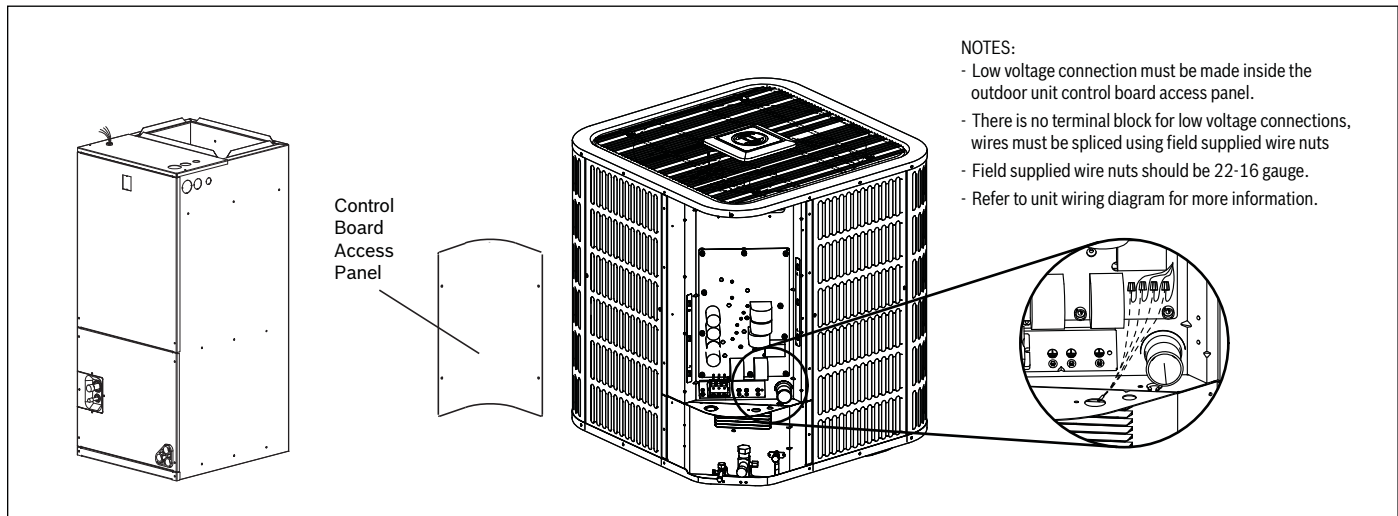

Figure 24 Low Voltage Unit Connections

11.3 Thermostat Wiring Diagrams

- ▶ Be sure power supply agrees with equipment nameplate.
- ▶ Power wiring and grounding of equipment must comply with local codes.
- ▶ Low voltage wiring to be No. 18 AWG minimum conductor.
- ▶ "-----" Field installed electric auxiliary heat connection
- ▶ Single-stage auxiliary heating supported by 2H thermostat
- ▶ Twin-stage auxiliary heating supported by 3H thermostat
- ▶ W1: The first stage of field installed electric auxiliary heat.
- ▶ W2: The second stage of field installed electric auxiliary heat.
- ▶ The outdoor unit W signal is connected to the electric auxiliary heat or the first stage electric auxiliary heat.

i Dashed lines in the following thermostat wiring diagrams refer to optional wiring (wiring for Passive Dehumidification Function and/OR Electric Heat). For thermostat wiring please refer to the Owner's Manual of the thermostat.

i B terminal to be connected with thermostat (O/B) wiring. Reversing valve energizes in heating.

i Figures 25-30 refer to thermostat wiring diagrams for the BOVA2.0 and BVA2.0 manufacturer matched indoor and outdoor systems.

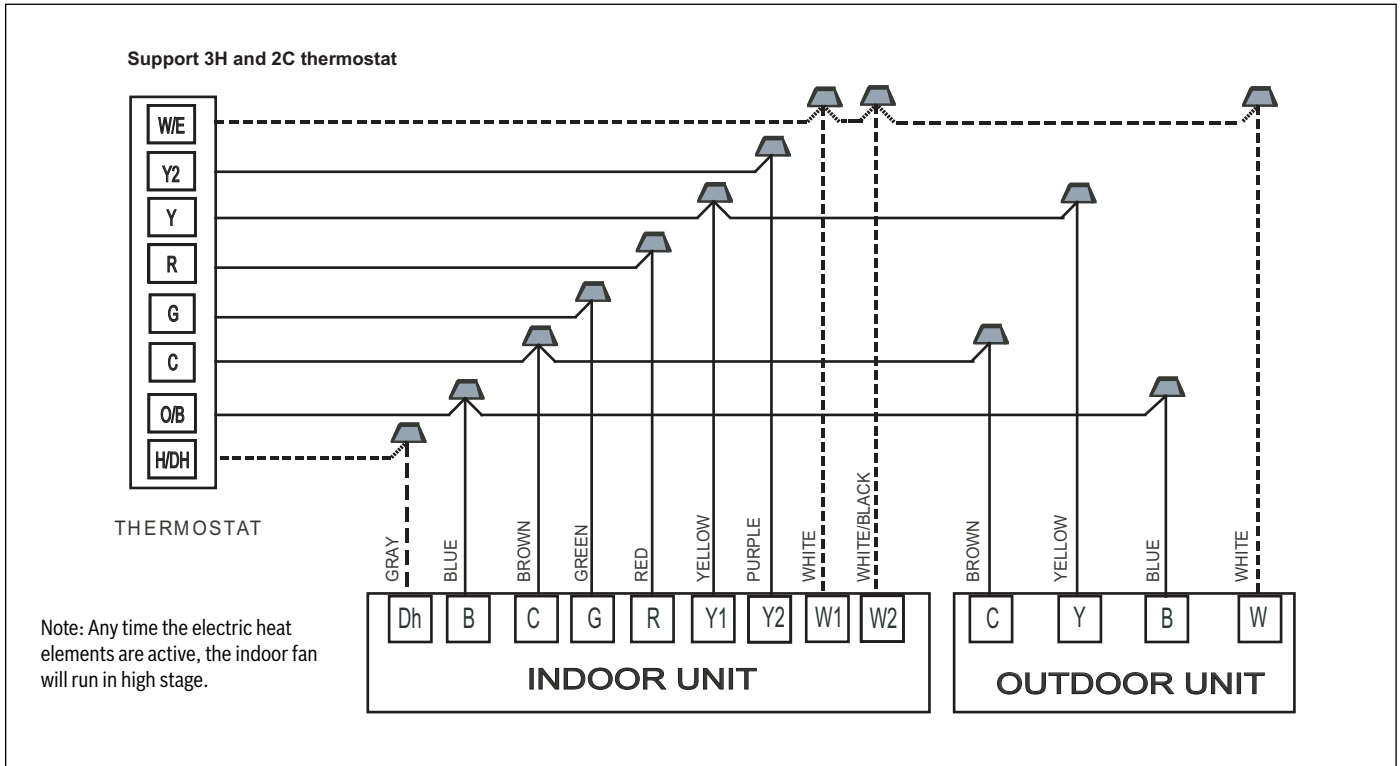

Figure 25 Thermostat Wiring Diagram for BOVA2.0/BVA2.0 Matched System

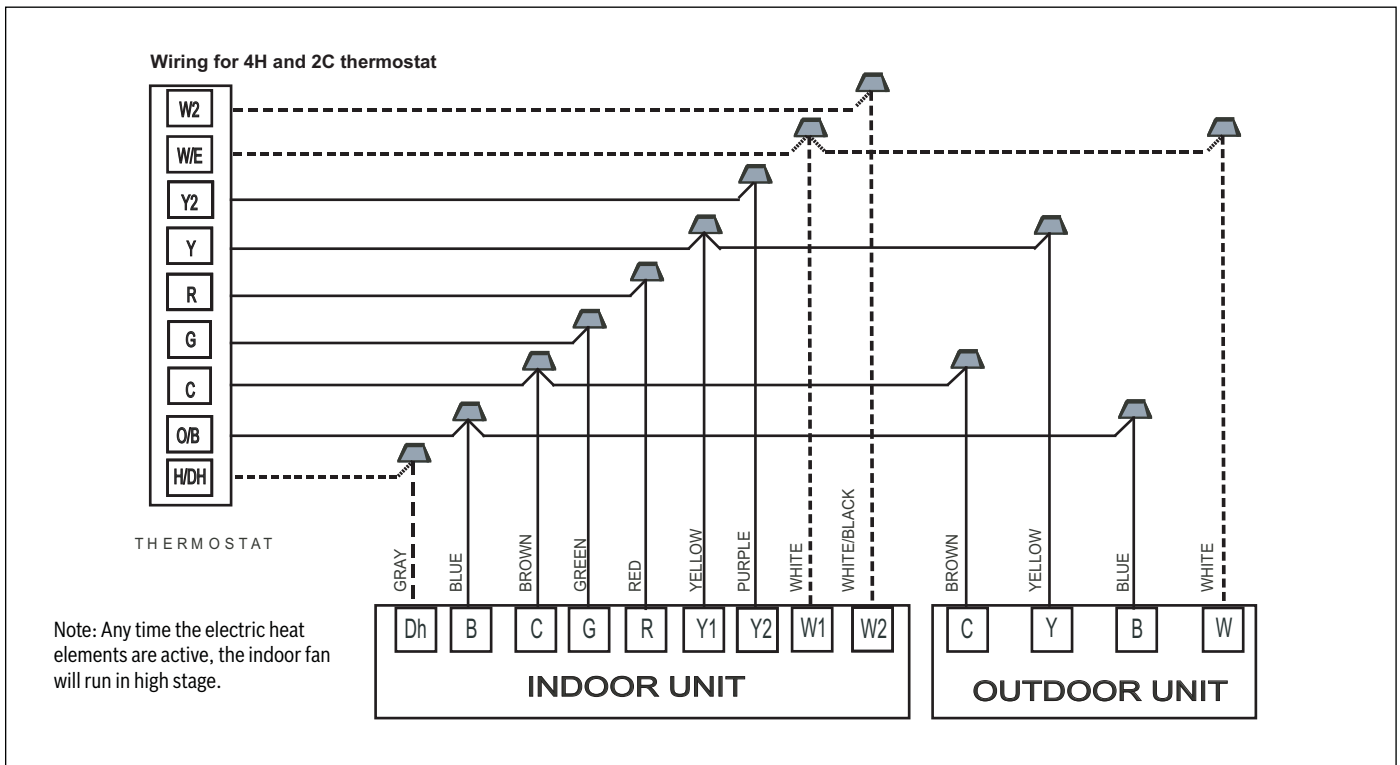

Figure 26 Thermostat Wiring Diagram for BOVA2.0/BVA2.0 Matched System

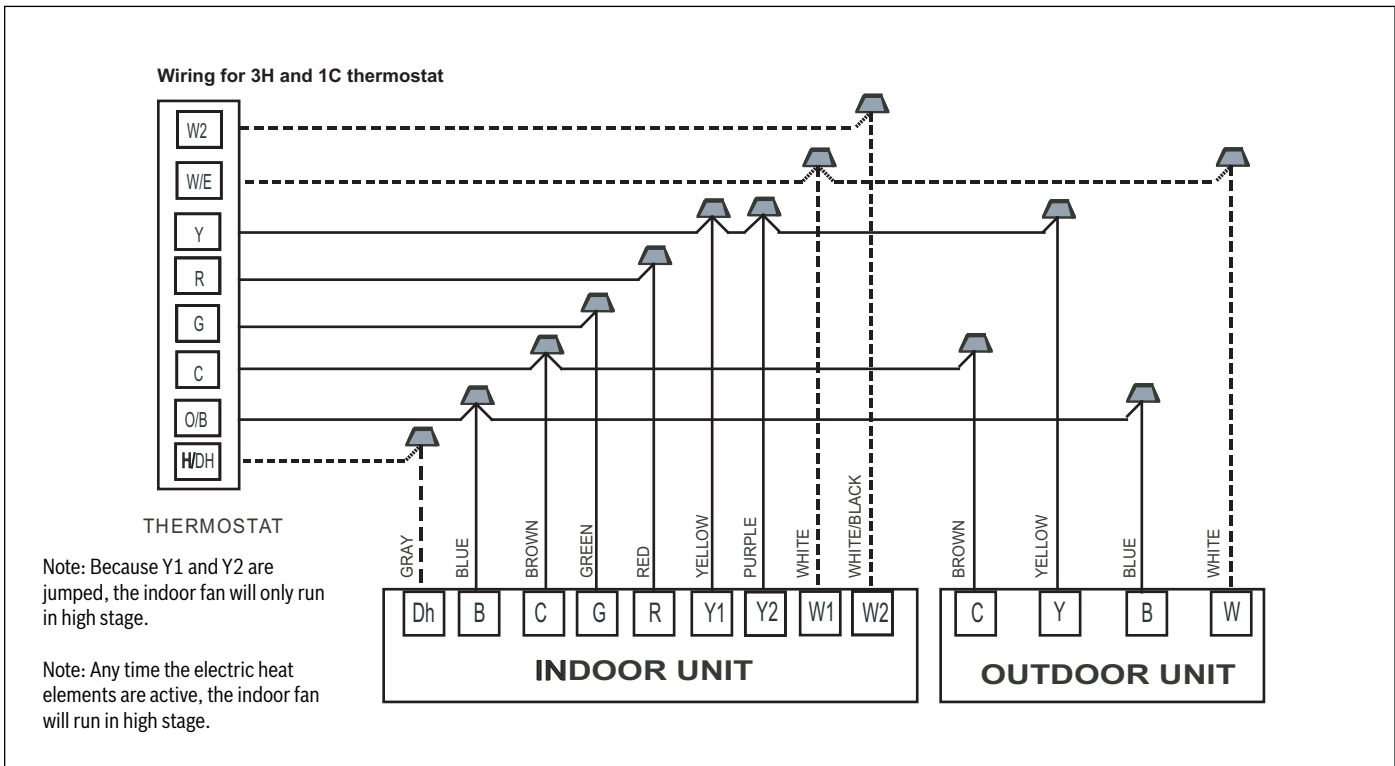

Figure 27 Thermostat Wiring Diagram for BOVA2.0/BVA2.0 Matched System

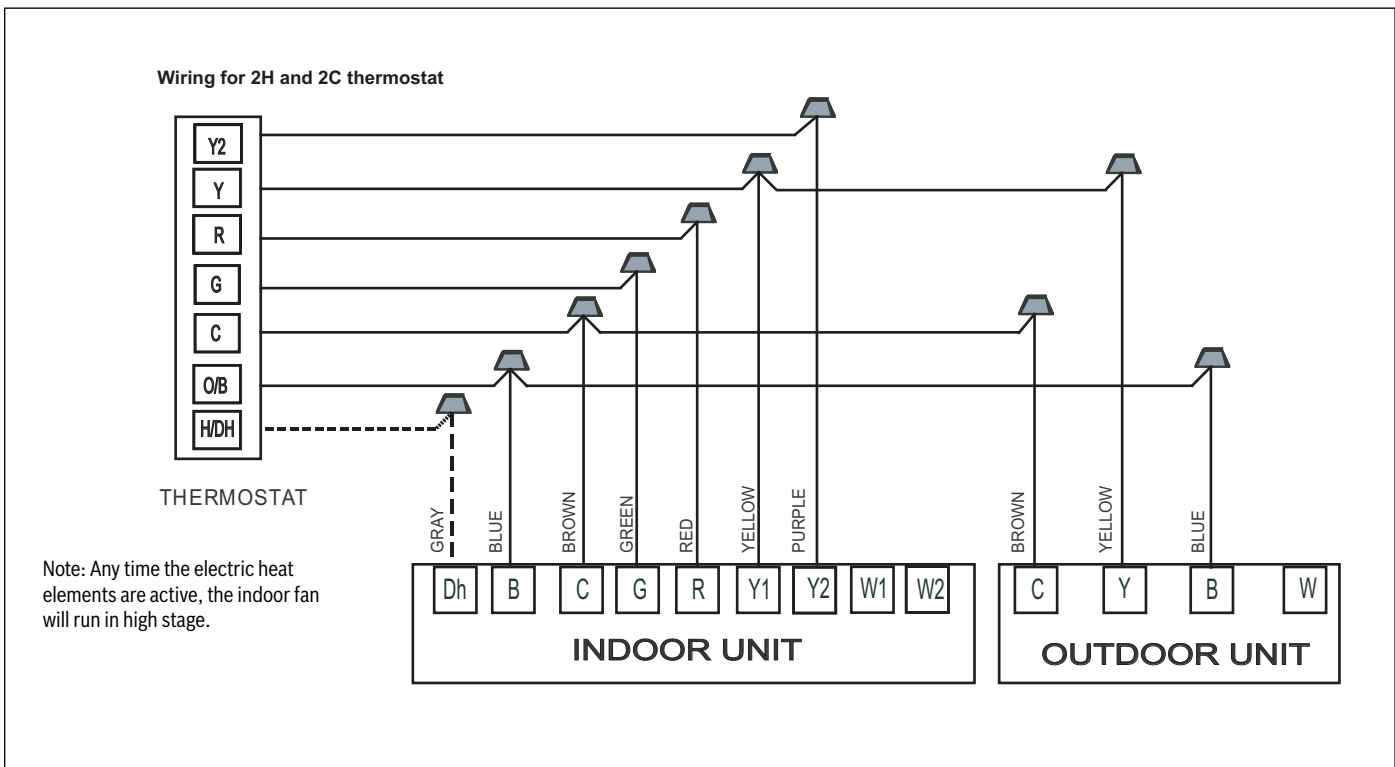

Figure 28 Thermostat Wiring Diagram for BOVA2.0/BVA2.0 Matched System

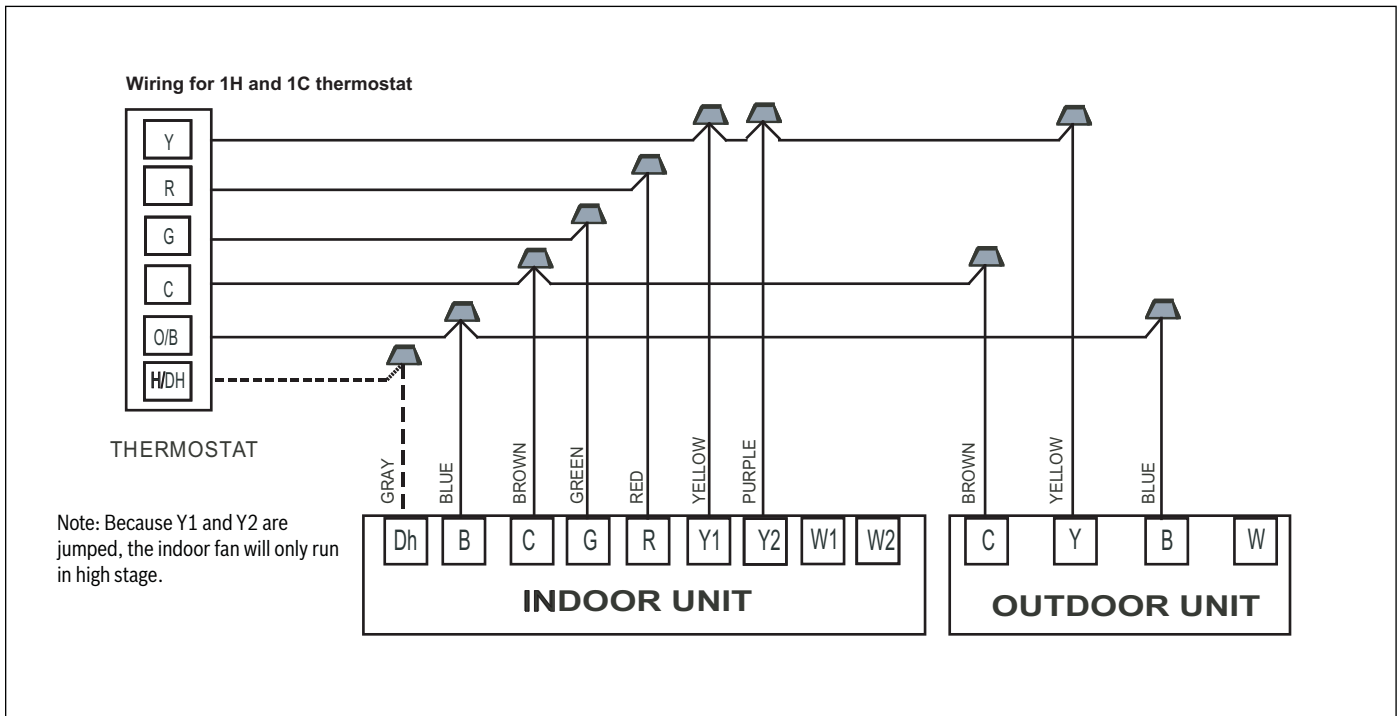

Figure 29 Thermostat Wiring Diagram for BOVA2.0/BVA2.0 Matched System

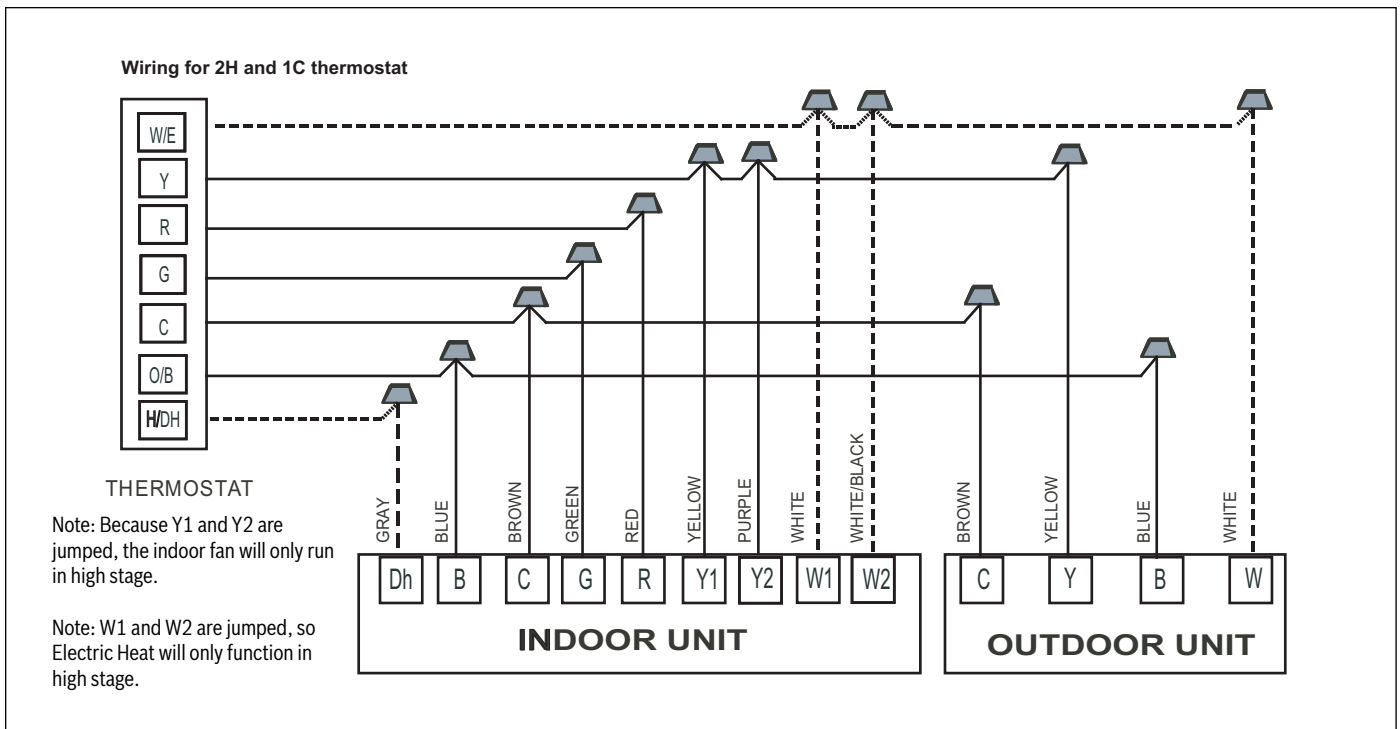

Figure 30 Thermostat Wiring Diagram for BOVA2.0/BVA2.0 Matched System

12 Electrical - High Voltage

12.1 High Voltage Power Supply



WARNING: LIVE ELECTRICAL COMPONENTS!

- ▶ During installation, testing, servicing, and trouble shooting of this product, it may be necessary to work with live electrical components. Failure to follow all electrical safety precautions when exposed to live electrical components could result in death or serious injury.

The high voltage power supply must match the equipment nameplate (208/230V, 1PH, 60Hz).



Power wiring must comply with national, state, and local codes.

Follow instructions on unit wiring diagram located on the inside of the control box access panel and refer to wiring diagram in this IOM.

12.2 High Voltage Disconnect Switch

Install a separate disconnect switch at the outdoor unit.

Field supplied flexible electrical conduit must be used for high voltage wiring.

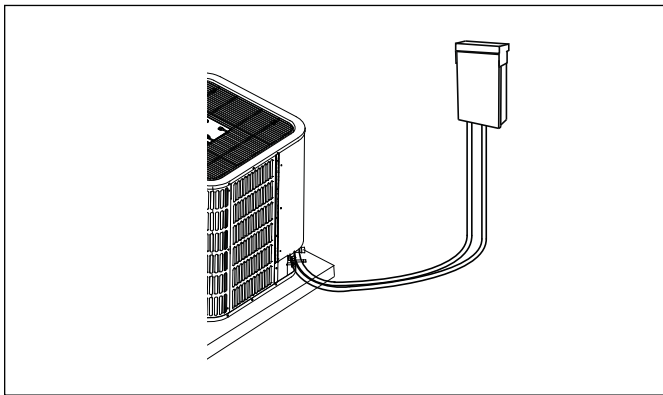

Figure 31

12.3 High Voltage Ground

Ground the outdoor unit per national, state, and local code requirements.

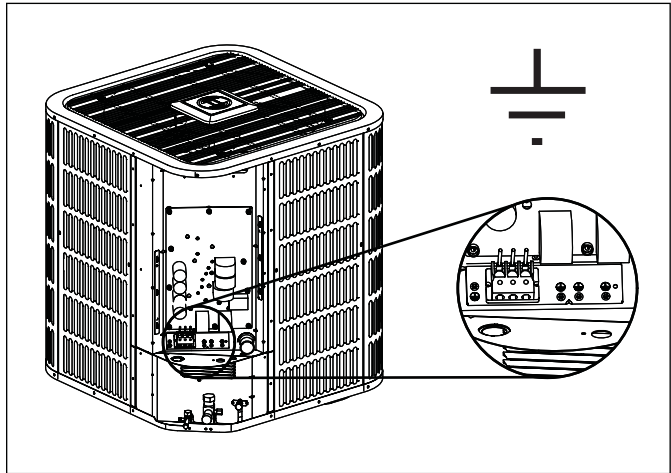

Figure 32

13 Start Up

13.1 System Start Up

1. Ensure Sections 7, 8, 9, 10, 11, and 12 have been completed.
2. Set System Thermostat to OFF.



Figure 33

3. Turn on disconnect to apply power to the indoor and outdoor units.

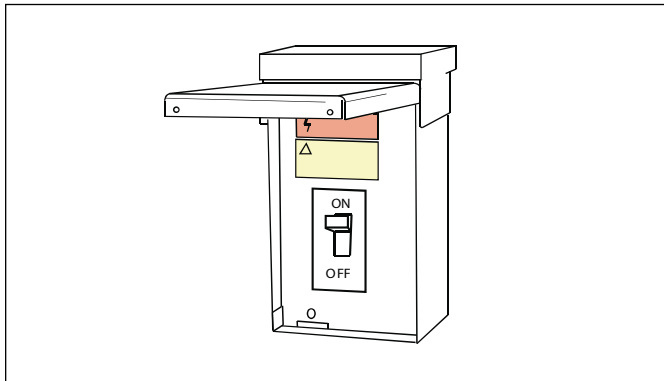

Figure 34

4. Upon initial unit installation, wait one (1) hour before starting the unit if compressor crankcase heater is used and the outdoor ambient temperature is below 70 °F.



Figure 35

5. Set system thermostat to ON.



Figure 36

14 System Charge Adjustment

14.1 Charging: Weigh-In Method

Use weigh-in method the initial installation, or anytime a system charge is being replaced. Weigh-in method can also be used when power is not available to the equipment site or operating conditions (indoor/outdoor temperatures) are not in range to verify with the subcooling charging method.

Model	Factory Charge	Charge multiplier for interconnecting refrigerant tube length
3 Ton	7 lbs 9 oz	0.6 oz/ft
5 Ton	11 lbs 5 oz	0.6 oz/ft

Table 5

i The factory charge in the outdoor unit is sufficient for 15 feet of standard size interconnecting liquid line.

New Installations – Calculating additional charge for lineset greater than 15 ft.

- Total Line Length (ft) = _____ (a)
- Standard Lineset (ft) = 15 (b)
- (a) minus (b) = _____ (c)
- Refrigerant Multiplier = 0.6 oz/ft (d)
- Refrigerant Adder (c*d) = _____ (e)*

*If lineset is less than 15 ft, (e) = 0

Sealed-System Repairs – Calculating total system charge.

- Total Line Length (ft) = _____ (a)
- Standard Lineset (ft) = 15 (b)
- (a) minus (b) = _____ (c)
- Refrigerant Multiplier = 0.6 oz/ft (d)
- Refrigerant Adder (c*d) = _____ (e)*
- Factory Charge (namplate) = _____ (f)
- Total System Charge (e+f) = _____

*If lineset is less than 15 ft, (e) = 0

i The only mode approved for validating system charge is while in Cooling "Force Mode". Outdoor temperature must be between 55°F and 120°F with indoor temperature kept between 70°F and 80°F.

14.2 Subcooling Charging And Refrigerant Adjustment In Cooling (Above 55°F Outdoor Temp.)

- Check the outdoor ambient temperatures.

Subcooling (**in cooling mode**) is the only recommended method of charging above 55°F outdoor ambient temperatures.

For outdoor ambient temperatures below 55°F use weigh-in charge method.

i It is important to return in the spring or summer to accurately charge the system in the cooling mode when outdoor ambient temperature is above 55°F.

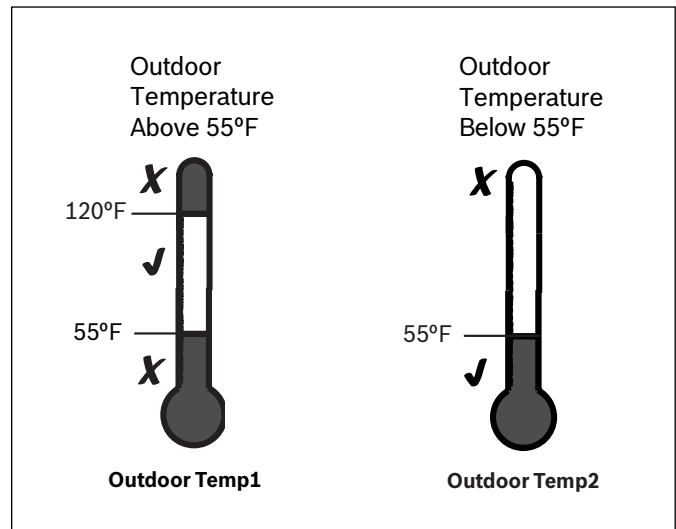

Figure 37

For best results, the indoor temperature should be kept between 70°F and 80°F during the install.

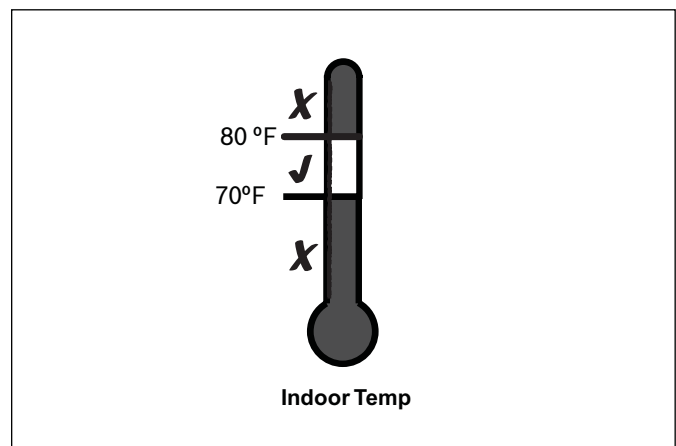

Figure 38

- Ensure Sections 7,8,9,10,11,12 and 13 have been completed.

3. Stabilize the system.

After **starting the system in cooling mode**, short press “FORCE” button, and “+” symbol should appear. System may take 10 minutes to ramp up. Operate the system for a minimum of twenty (20) minutes.

i After a twenty (20) minute stabilization period operating at 100% capacity (i.e. once the compressor reaches the frequency shown in Table 6), maintain continuous operation while adjusting refrigerant charge. After adjusting, operate system for a minimum of five (5) minutes for system to stabilize, otherwise repeat step 3.

Compressor Frequency in Force Mode in Cooling				
ODU Capacity	2TON	3TON	4TON	5TON
Frequency (HZ)	48	72	54	62

Table 6



Figure 39

4. Calculate superheat value (According to Table 7)

- ▶ Measured Suction Line Temp = _____°F
- ▶ Measured Suction Line Pressure = _____PSIG
- ▶ Calculate superheat value = _____°F

i For indoor unit with adjustable TXV, set subcooling and adjust superheat via adjustable TXV according to Table 9. For indoor unit with non-adjustable TXV, check the superheat and set correct subcooling according to superheat, refer to Table 9.

5. Calculate subcooling value (According to Table 8)

- ▶ Measured Liquid Line Temp. = _____°F
- ▶ Measured Liquid Line Pressure = _____PSIG
- ▶ Calculate subcooling value = _____°F

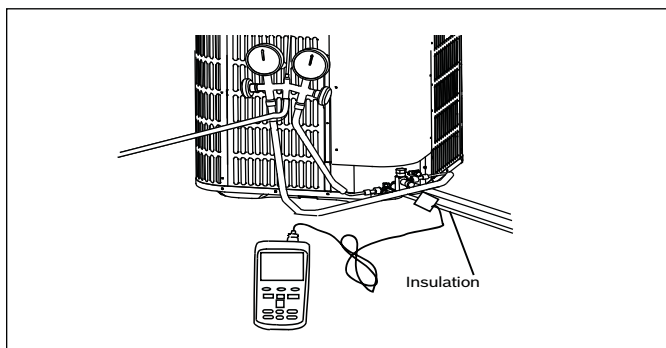

Figure 40

i If calculated subcooling value is lower than the design subcooling value (Table 9), please add refrigerant. Repeat steps 3 through 5.

i If the superheat is out of range, refer to Troubleshooting section of this IOM.

Suction Temp (°F)	Final Superheat (°F)								
	6	8	10	12	14	16	18	20	22
	Suction Gauge Pressure (PSI)								
40	105	101	97	93	89	86	82	78	75
42	109	105	101	97	93	89	86	82	78
44	114	109	105	101	97	93	89	86	82
46	118	114	109	105	101	97	93	89	86
48	123	118	114	109	105	101	97	93	89
50	128	123	118	114	109	105	101	97	93
52	133	128	123	118	114	109	105	101	97
54	138	133	128	123	118	114	109	105	101
56	143	138	133	128	123	118	114	109	105
58	148	143	138	133	128	123	118	114	109
60	153	148	143	138	133	128	123	118	114
62	159	153	148	143	138	133	128	123	118
64	164	159	153	148	143	138	133	128	123
66	170	164	159	153	148	143	138	133	128
68	176	170	164	159	153	148	143	138	133
70	182	176	170	164	159	153	148	143	138
72	188	182	176	170	164	159	153	148	143

Table 7 R-410A Refrigerant chart - Final Superheat

Liquid Temp (°F)	Final Subcooling (°F)							
	6	7	8	9	10	11	12	13
	Liquid Gauge Pressure (PSI)							
55	173	176	179	182	185	188	191	195
60	188	191	195	198	201	204	208	211
65	204	208	211	215	218	221	225	229
70	221	225	229	232	236	239	243	247
75	239	243	247	251	255	259	262	266
80	259	262	266	270	275	279	283	287
85	279	283	287	291	295	300	304	309
90	300	304	309	313	318	322	327	331
95	322	327	331	336	341	346	351	355
100	346	351	355	360	365	370	376	381
105	370	376	381	386	391	397	402	407
110	397	402	407	413	418	424	430	435
115	424	430	435	441	447	453	459	465
120	453	459	465	471	477	483	489	496
125	483	489	496	502	508	515	521	528

Table 8 R-410A Refrigerant chart - Final Subcooling

Figure 41

Model	Design Subcooling		Note
	Subcooling/°F	Superheat/°F	
24K/36K	10±2	10~18	Specification applicable for indoor units with adjustable or non-adjustable TXV
	8±2	7~10	Specification applicable for indoor units with non-adjustable TXV
48K	8±2	9~18	Specification applicable for indoor units with adjustable or non-adjustable TXV
	6±2	7~9	Specification applicable for indoor units with non-adjustable TXV
60K	8±2	8~18	Specification applicable for indoor units with adjustable or non-adjustable TXV
	6±2	6~8	Specification applicable for indoor units with non-adjustable TXV

Table 9

6. Adjust refrigerant level to attain proper gauge pressure.

i **Add refrigerant** if the subcooling reading from Table 8 is lower than the designed value (Table 9).

- ▶ Connect gauges to refrigerant bottle and unit as illustrated (Fig. 41).
- ▶ Purge all hoses.
- ▶ Open tank.
- ▶ Stop adding refrigerant when subcooling matches the design value (Table 9).

i **Recover refrigerant** if the subcooling reading from Table 8 is higher than the design value (Table 9).

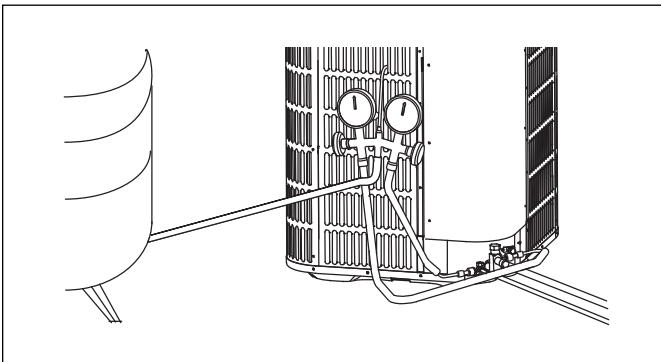

Figure 42

7. Stabilize the system.
 ▶ Wait 5 minutes for the system condition to stabilize between adjustments.

i When the subcooling matches the design value (Table 9), the system is properly charged.

- ▶ Remove gauges.
 - ▶ Replace service port caps to prevent leaks. Tighten finger tight plus an additional 1/6 turn.
8. Record System Information for reference (Table 10).
 Record system pressures and temperatures after charging is complete.

Description	Value
Outdoor model number	
Measured Outdoor Ambient	°F
Measured Indoor Ambient	°F
Measured Liquid Line Temp	°F
Measured Suction Line Temp	°F
Liquid Gauge Pressure	PSIG
Suction Gauge Pressure	PSIG

Table 10

15 System Operation and Troubleshooting

15.1 Control Logic Description

- ▶ The variable speed system adopts the same 24VAC control as any conventional heat pump.
- ▶ The compressor's speed is controlled based on coil pressures monitored by the unit's pressure transducer. To ensure stable and adequate capacity, the compressor speed will modulate relative to evaporator pressure during cooling operation and relative to condensing pressure during heating operation. The target pressure can automatically adjust based on compressor operation so optimal capacity can be achieved. Target pressure can be manually adjusted (SW4) to achieve improved dehumidification and capacity demands.

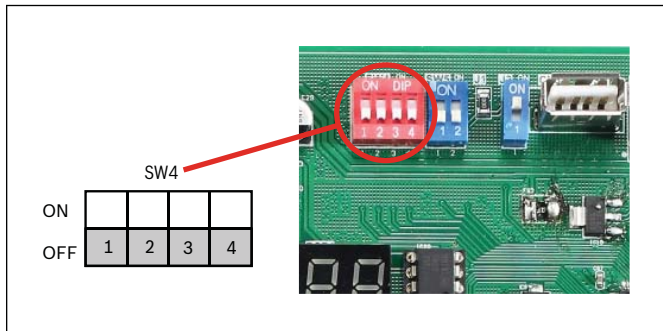

Figure 43

Switch		Description
SW4-1	ON	Unused
	OFF*	Must be set at "OFF" position
SW4-2	ON	Unused
	OFF*	Must be set at "OFF" position
SW4-3	ON	Adaptive capacity output disabled
	OFF*	Adaptive capacity output enabled
SW4-4	ON	Accelerated cooling/heating
	OFF*	Normally cooling/heating

Table 11

*Factory Default

- ▶ Adaptive capacity function is a "self-learning function" which allows a range of target coil temperatures to adapt for better unit operation and reduced short cycling.
- ▶ Accelerated cooling/heating function changes the initial target coil temperature to provide "enhanced comfort" by increasing unit capacity.

15.2 Sensors (Thermistors/Pressure Transducer)

- ▶ T3 = Outdoor Coil Temperature (Table 24)
 - High/Low temperature protection
 - Outdoor fan control (cooling mode)
 - Defrost control (heating mode)
- ▶ T4 = Ambient Temperature (Table 24)
 - Operating condition permission
 - Defrosting condition permission
 - Outdoor fan control (heating mode)
- ▶ T5 = Compressor Discharge Temperature (Table 25)
 - High/Low temperature protection
 - Electronic Expansion Valve (EEV) (ODU/heating mode only)
- ▶ Th = Compressor Return Temperature (Table 24)
- ▶ T3L = Liquid Line Temperature (Table 24)
- ▶ TF = IPM Radiator Temperature (Table 25)
 - Inverter High Temperature Protection
- ▶ Pressure transducer
 - Compressor frequency control
 - Electronic Expansion Valve (EEV) control (heating mode only)
 - High pressure protection (heating mode)
 - Low pressure protection (cooling mode)

15.3 Pressure Equalizer Valve (PEV)

Used to balance the pressure in the system before compressor start up.

15.4 Defrost Description

- ▶ The Demand Defrost Control (DDC) monitors the ODU coil temperature using thermistor (T3). A second thermistor (T4) monitors outdoor ambient temperature. Based on these parameters, as well as accumulative run time and high pressure, the DDC calculates proper initiation of defrost.
- ▶ Any one of the below three conditions is required to enter defrost:
 1. The calculated temperature difference between the outdoor temperature (T4) and the coil temperature (T3) is called Delta T. After Delta T is achieved and continues for 3 minutes.
 - T4 ≥ 39°F, Delta T = 18°F
 - T4 ≥ 30°F, Delta T = 16°F
 - T4 ≥ 19°F, Delta T = 14°F
 - When T4 < 19°F, T3 < 9°F, accumulative compressor run time ≥ 80 minutes.
 2. After "Minimum Run Time" (MRT) is achieved. MRT is based on outdoor ambient temperature (T4), for example:
 - MRT is 4 hours when: T4 < 23°F
 - MRT is 2 hours when: 23°F ≤ T4 < 42°F
 3. After the high pressure saturation temperature drops below 82°F for 20 minutes.
- ▶ Defrost will terminate once outdoor coil temperature (T3) reaches 64°F for a period of 1 minute or defrost time has exceeded 8 minutes.

- ▶ Defrost Termination Settings (SW5) offers different defrost termination options for enhanced defrost for different geographical and outdoor conditions.

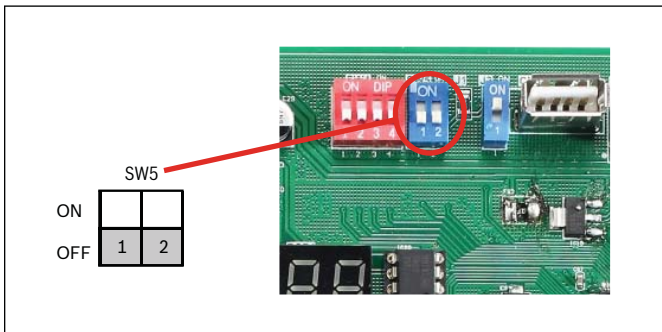

Figure 44

Defrosting Choice	SW5-1	SW5-2	Remarks
ON	Operating time is reduced by 10%	Defrosting extended for 60 seconds	
OFF	Normal	Normal	Default
Remarks	Enter defrost	Quit defrost	

Table 12

- ▶ Manual Defrost:
 1. System must have a call for heat and have been operating for a minimum of 8 minutes.
 2. Press "Force" button on inverter board for 6 seconds to begin forced defrost.
 3. Wait approximately 40 seconds for defrost to initiate.
 4. Once defrost initiates, the display will indicate "dF".
 5. Defrost test will terminate automatically, after which the display will indicate running speed.
 6. If a second defrost test is required, repeat steps 2-5 after 5 minutes.

15.5 Compressor Crankcase Heater Description

Refrigerant migration during the OFF cycle can result in noisy start-ups, therefore a CrankCase Heater (CCH) is used to minimize refrigerant migration thereby minimizing start-up noise and/or bearing "wash out". All CCHs must be installed on the lower half of the compressor shell. Its purpose is to warm the compressor during the OFF cycle, driving refrigerant from compressor. After extended shutdown periods in cold weather, it is recommended to allow CCH to be energized for at least 12 hours prior to compressor operation by applying line voltage to heat pump with thermostat OFF.

- ▶ CCH operation energizes:
 1. First time line voltage is applied and compressor discharge temperature $T5 < 53.6^{\circ}\text{F}$.
 2. Compressor stops running for 3 hours (outdoor ambient temperature $T4 < 41^{\circ}\text{F}$ OR compressor discharge temperature $T5 < 53.6^{\circ}\text{F}$).
- ▶ CCH operation de-energizes:
 1. Compressor discharge temperature $T5 \geq 60.8^{\circ}\text{F}$.
 2. Compressor start running.

15.6 Reversing Valve Operation

- ▶ Reversing valve energizes during heat mode and de-energizes in cool mode.



During a heat call on first time operation the unit will run about 1 minute in cooling to build up pressure for reversing valve to change.

15.7 Protection Functions

- ▶ Outdoor coil temperature protection (T3)
 - i. If $T3 > 143.6^{\circ}\text{F}$, compressor is de-energized.
 - ii. If $T3 < 129.2^{\circ}\text{F}$, compressor is energized.
- ▶ Ambient temperature protection (T4)
 - i. If $15^{\circ}\text{F} \leq T4 < 125^{\circ}\text{F}$, unit can operate in cooling.
 - ii. If $-4^{\circ}\text{F} \leq T4 < 86^{\circ}\text{F}$, unit can operate in heating.
 - iii. If $T4 < -4^{\circ}\text{F}$, heat pump will provide 24V control to indoor unit energizing electric heat (if installed).



See BOVA 2.0 Product Specification for extended performance data.

- ▶ Discharge Temperature (DT) protection (T5)
 - i. If $DT > 239^{\circ}\text{F}$ during cooling mode, the compressor will stop.
 - ii. If $DT < 194^{\circ}\text{F}$ during cooling mode, the compressor will restart.
 - iii. If $DT > 221^{\circ}\text{F}$ during heating mode, the compressor will stop.
 - iv. If $DT < 167^{\circ}\text{F}$ during heating mode, the compressor will restart.
- ▶ High Pressure (HP) protection (mechanical open/close pressure switch)
 - i. High Pressure Switch opens at $P > 580$ PSIG, the compressor and outdoor fan stop.
 - ii. High Pressure Switch closes at $P < 435$ PSIG, the compressor and outdoor fan restart.
- ▶ Low Pressure (LP) protection
 - i. If Low Pressure < 43.5 PSI for 5 minutes during cooling mode, the compressor and outdoor fan will stop. The system will attempt to run again after 6 minutes.
 - ii. If condensing temp. $Tc < \text{outdoor ambient temp. } T4$ during heating mode, the compressor and outdoor fan will stop.
- ▶ Module (inverter) protection (TF)
 - i. If $TF > 176^{\circ}\text{F}$, the compressor and outdoor fan will stop.
 - ii. If $TF < 145^{\circ}\text{F}$, the compressor and outdoor fan will restart.

15.8 Fault Code Table

Code	Fault Description (Sensor)
C3	The coil sensor is seated fault in cooling (T3)
E4	Temperature sensor fault (T3, T4, T5, Th, T3L, TF)
E5	High/low voltage protection
E6	DC fan motor fault
E7	Compressor discharge sensor is seated fault (T5)
E9	EEPROM fault
H0	Communication fault in main control chip
H5*	5 times (P2) protection in 100 minutes, system lockout
H8	Pressure transducer fault (PT)
P0	High module radiator temperature protection (TF)
P1	High pressure switch protection (HPS)
P2	Low pressure protection in cooling or heating (PT)
P3	Compressor over current protection
P4	High compressor discharge temperature protection (T5)
P5	Condensor coil temperature protection in cooling (T3)
P8	DC fan motor hurricane/typhoon protection
PH	Low discharge superheat protection
F1	High pressure switch protection (HPS)
L0-L9	The IPM module protection
AtL	Ambient Temperature Limited
System Protection Status Codes**	
┆	Forced operation mode
L	Running indication under T3 limited condition
D	Running indication under T5 limited condition
P	Running indication under compressor ratio limited condition
F	Running indication under TF limited condition
C	Running indication under current limited condition
U	Running indication under low voltage limited condition
A	Running indication under return oil mode
dF	Running indication under defrost mode

Table 13

* Fault requires hard restart

** If the first digit shown on the control board LED is one of the following protection codes (followed by two numerical digits which show the current compressor frequency in Hz), the unit will continue to run but in a limited condition. The only exception is when the system is in defrost mode, which only displays "dF" (without any numerical digits following).

15.9 Parameter Point Check Table

- ▶ To display system parameters, press the “Check” button to index through the series of parameters available. The first time you press the “Check” button, it will display the sequence, and after 1 second it will display the value of the parameter. If you press the “Check” button again, it will display the next sequence. Refer to Figure 44 and 45 for check button location on the control board.
- ▶ Normal Status, last two digits will display under the following conditions
 - i. Unit not operating (Standby Mode); “outdoor ambient temperature”.
 - ii. Unit operating; displays “compressor operating frequency”.
- ▶ After 20 seconds on same parameter, the display will revert back to normal status.
- ▶ If a system protection is active, first digit will display “status code”.

No.	Point check content	Example	Remark
0	Outdoor unit capacity	H3	H3=Heat Pump 3 ton
1	Outdoor unit mode	2	0 standby, 2 cooling, 3 heating
2	Outdoor unit set compressor speed (Hz)	66	
3	T3 (outdoor coil temp.) (°F)		
4	T4 (outdoor ambient temp.) (°F)		
5	T5 (compressor discharge temp.) (°F)		
6	Th (compressor suction temp.) (°F)		
7	T3L (liquid line temp.) (°F)		
8	Tf (module temp.) (°F)		
9	Pe (evaporating pressure) (PSI)		Low Suction Pressure
10	Pc (condensing pressure) (PSI)		High Head Pressure
11	Tes target of the evaporating temp. (only use for cooling mode) (°F)		
12	Te (evaporating temp.) (°F)		
13	Tcs target of the condensing temp. (only use for heating mode) (°F)		
14	Tc (condensing temp.) (°F)		
15	Target of the compressor discharge superheat (only use for heating mode) (°F)		
16	Compressor discharge superheat (°F)		
17	Openings of EEV		
18	Fan speed		
19	Compressor current (A)		
20	Power AC voltage Input (V)		
21	Compressor input dc voltage (V)		
22	Continuous running time of the compressor (min)		
23	Last fault code	00	see Table 9-4
24	Software version	01	
25	Remark “-”	--	--

Table 14

15.10 Control Board Overviews

Main Control Board for 24/36 ODU Model

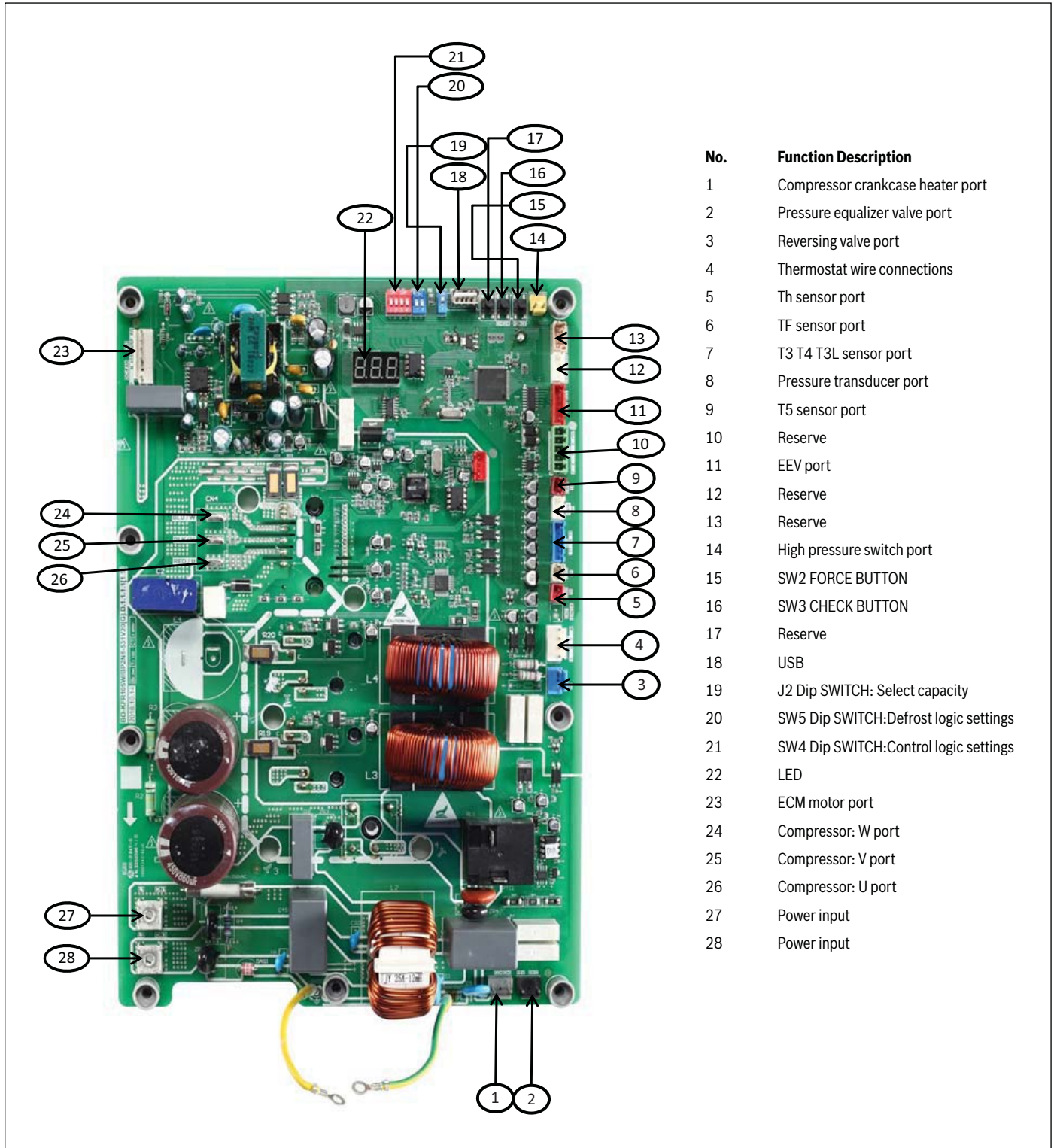
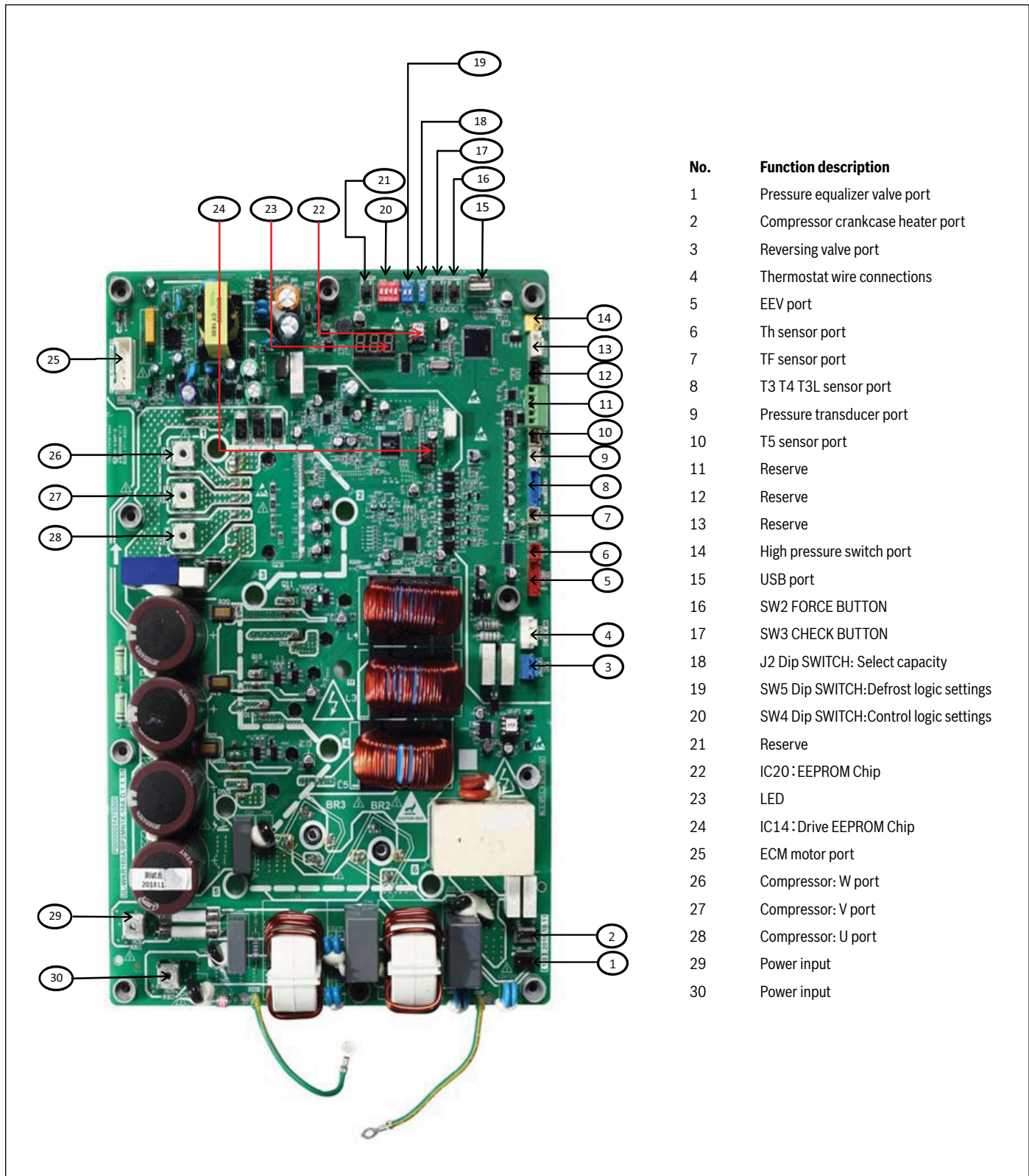

Figure 45

Main Control Board for 48/60 ODU Model



No.	Function description
1	Pressure equalizer valve port
2	Compressor crankcase heater port
3	Reversing valve port
4	Thermostat wire connections
5	EEV port
6	Th sensor port
7	TF sensor port
8	T3 T4 T3L sensor port
9	Pressure transducer port
10	T5 sensor port
11	Reserve
12	Reserve
13	Reserve
14	High pressure switch port
15	USB port
16	SW2 FORCE BUTTON
17	SW3 CHECK BUTTON
18	J2 Dip SWITCH: Select capacity
19	SW5 Dip SWITCH:Defrost logic settings
20	SW4 Dip SWITCH:Control logic settings
21	Reserve
22	IC20 : EEPROM Chip
23	LED
24	IC14 : Drive EEPROM Chip
25	ECM motor port
26	Compressor: W port
27	Compressor: V port
28	Compressor: U port
29	Power input
30	Power input

Figure 46

15.11 Error Code Troubleshooting

Error Code	Description (Sensor)
P1	High pressure switch (HPS) protection
P5	Condenser coil temperature (T3) protection in cooling
P3	Compressor over current protection

Table 15

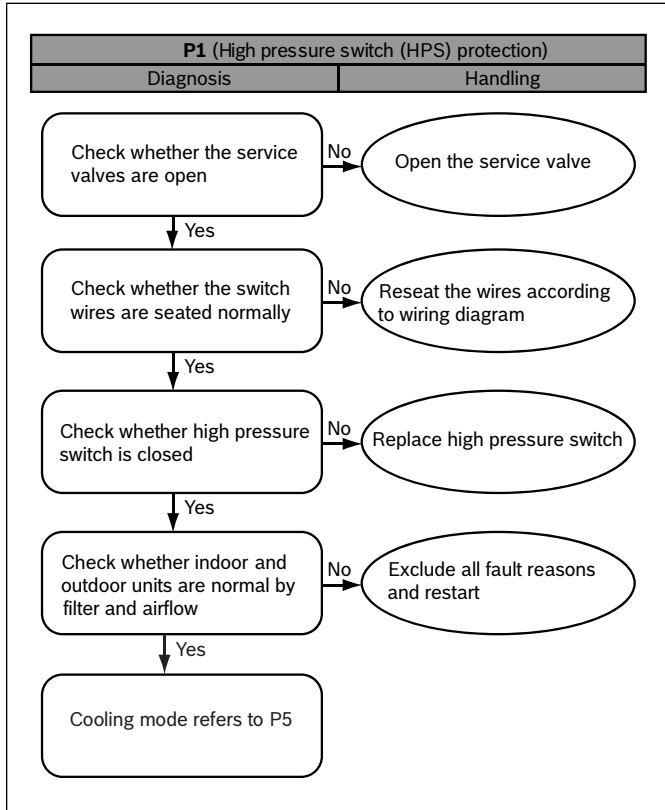

Figure 47

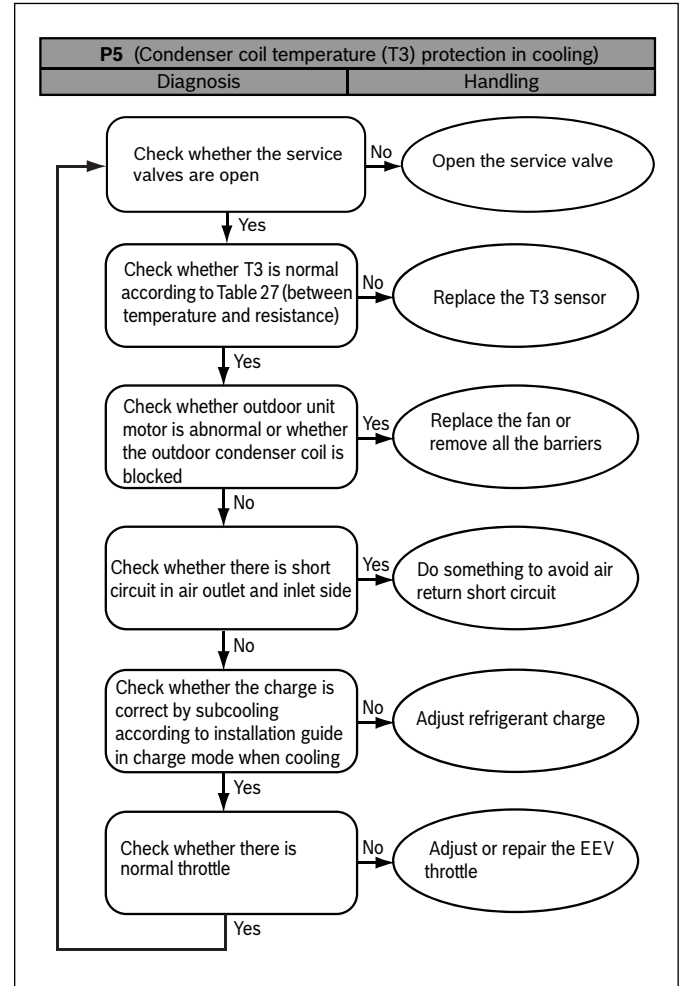

Figure 48

Error Code	Description
P2	Low pressure (PT) Protection in cooling and heating
H5	System lockup, 5 times (P2) protection in 100 minutes
P4	High compressor discharge temperature(T5) protection

Table 17

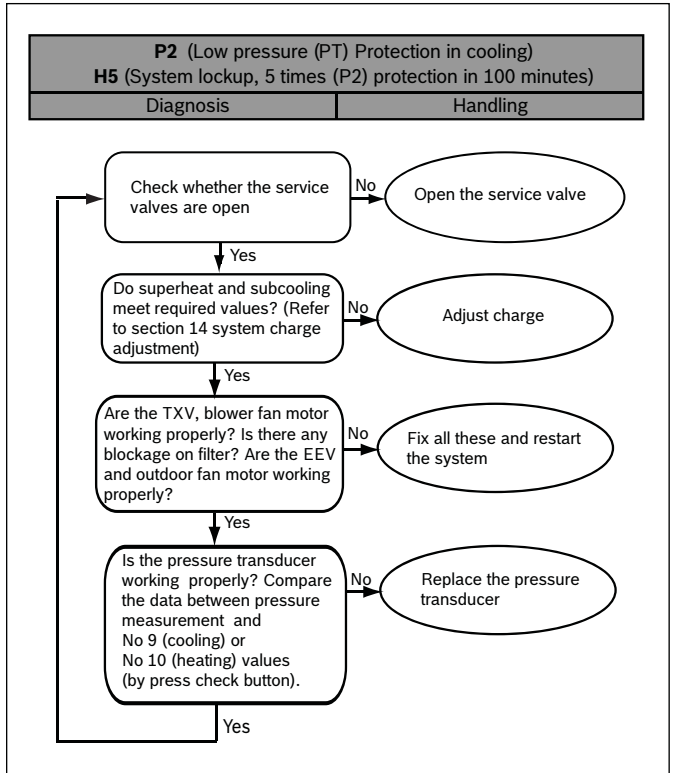

Figure 51

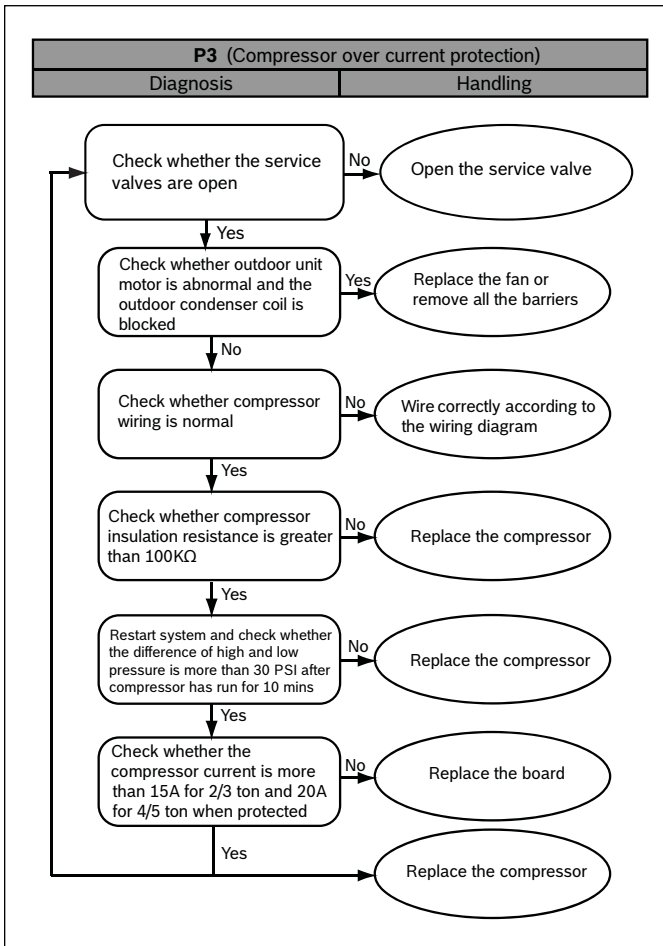

Figure 49

Error Code	Description
P0	High module radiator temperature (TF) protection

Table 16

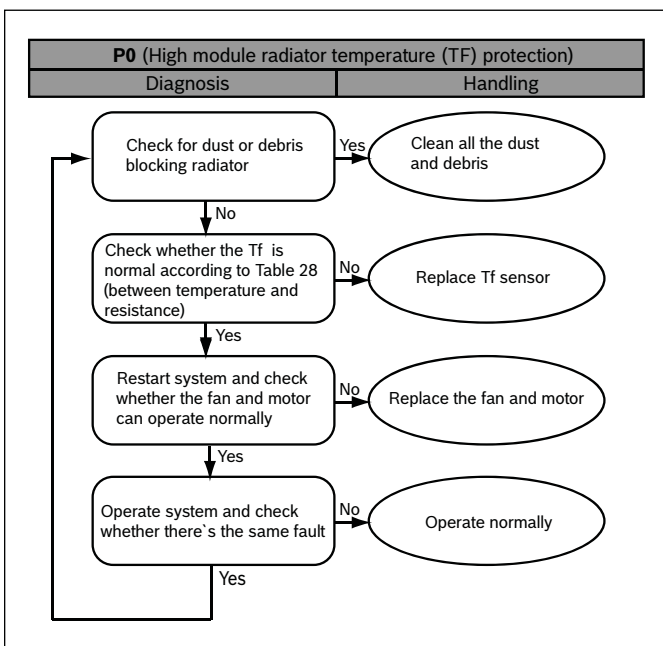

Figure 50

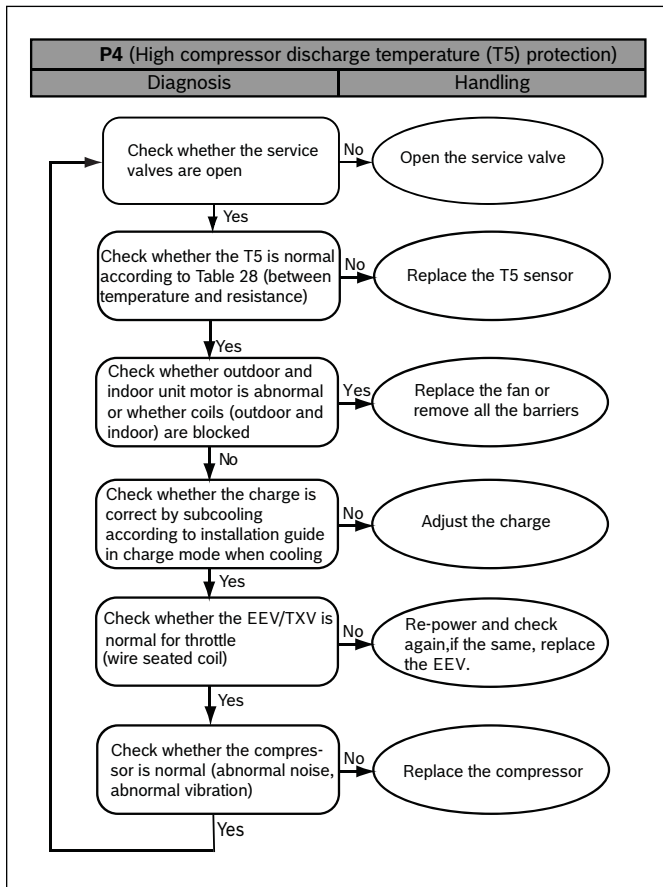

Figure 52

Error Code	Description
E4	Temperature sensor fault (T3, T4, T5, Th, T3L, TF)
H8	Pressure transducer (PT) fault
F1	High pressure switch (HPS) fault

Table 18

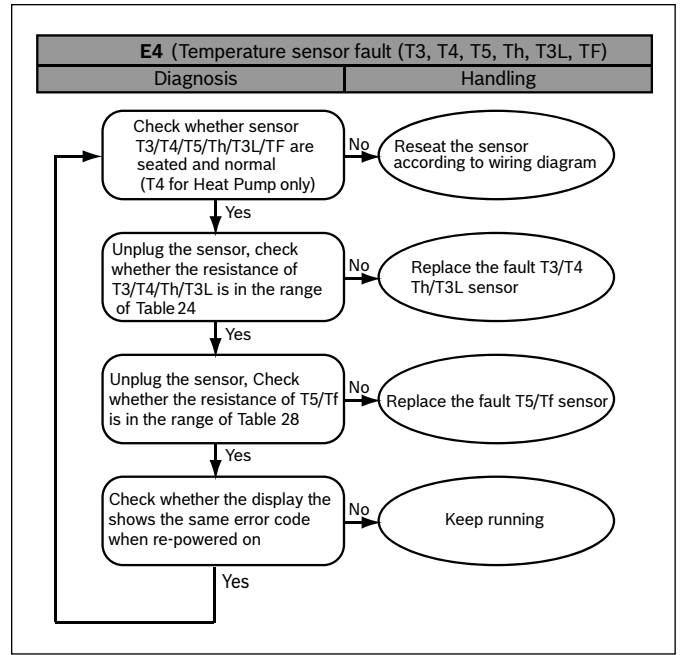

Figure 53

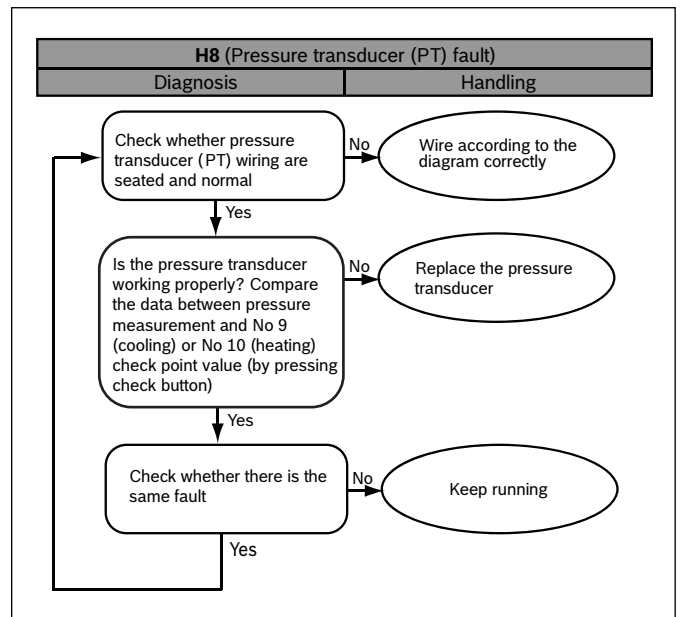

Figure 54

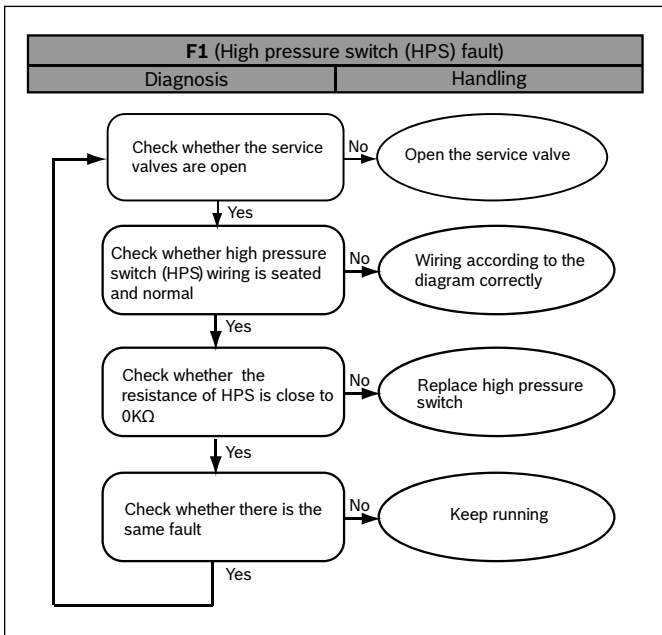

Figure 55

Error Code	Description
C3	Condenser coil sensor (T3) is seated fault in cooling
E7	Compressor discharge sensor (T5) is seated fault

Table 19

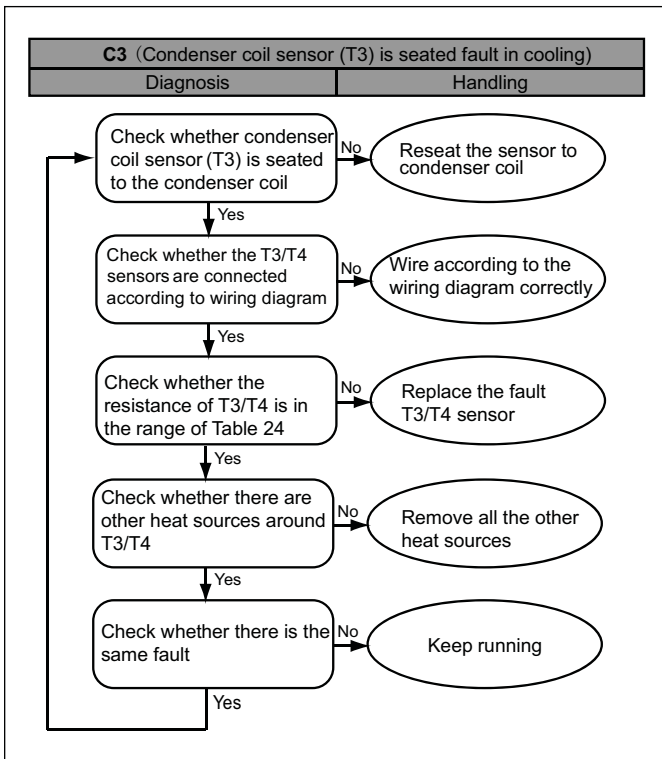

Figure 56

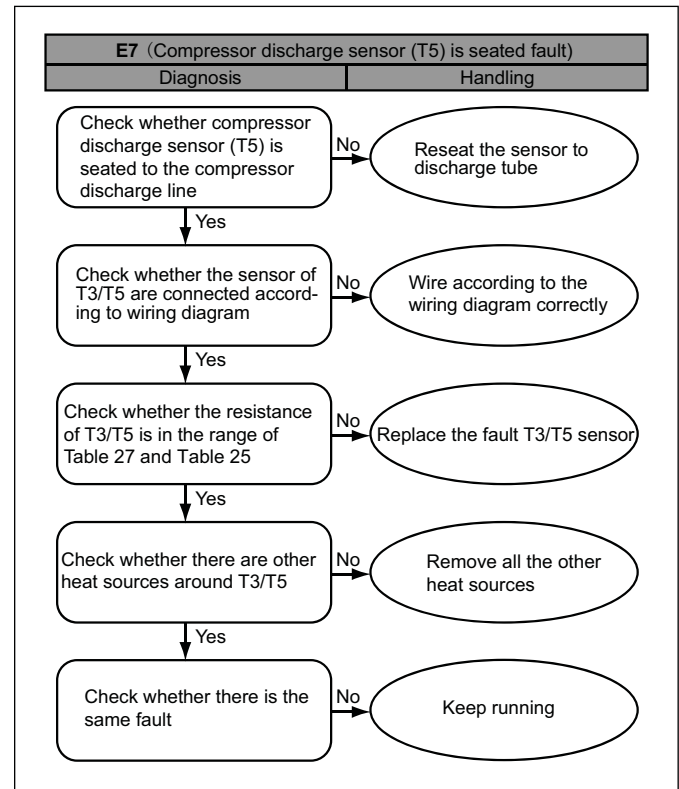

Figure 57

Error Code	Description
E6	DC fan motor fault

Table 20

If the E6 error code appears occasionally, no action is necessary. The system will restart automatically after 6 minutes.

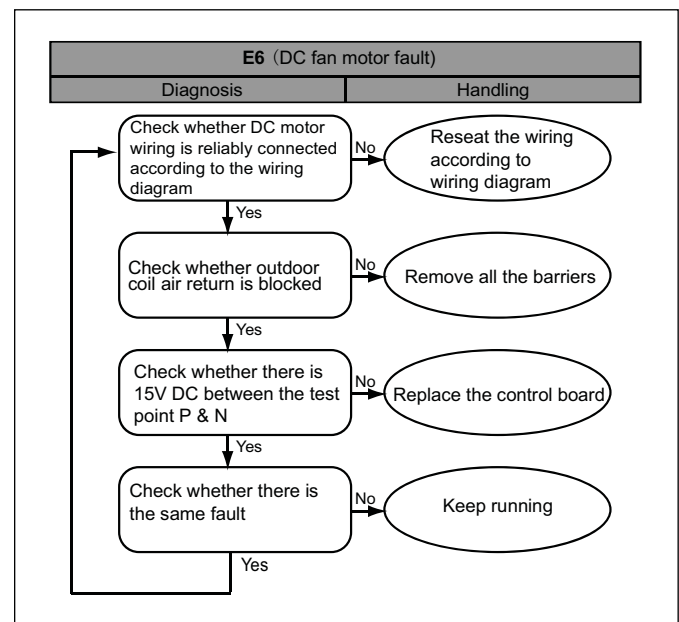

Figure 58

Error Code	Description
E9	EEPROM fault
H0	Communication fault in main control chip
E5	High/low voltage protection

Table 21

If error codes E9/H0/E5 appear occasionally and after the system restarts and runs normally after the power supply is re-established, no action is necessary. Otherwise the system must be checked.

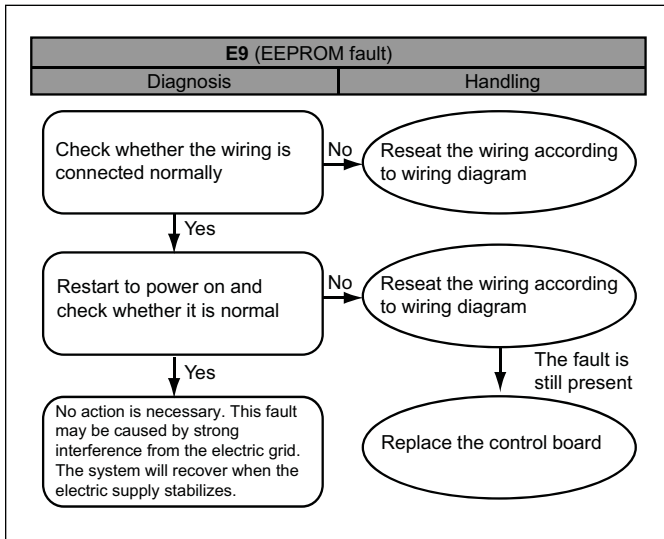

Figure 59

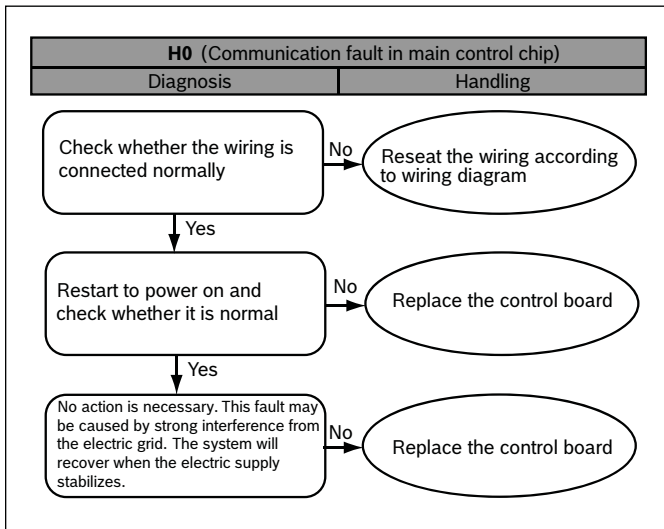

Figure 60

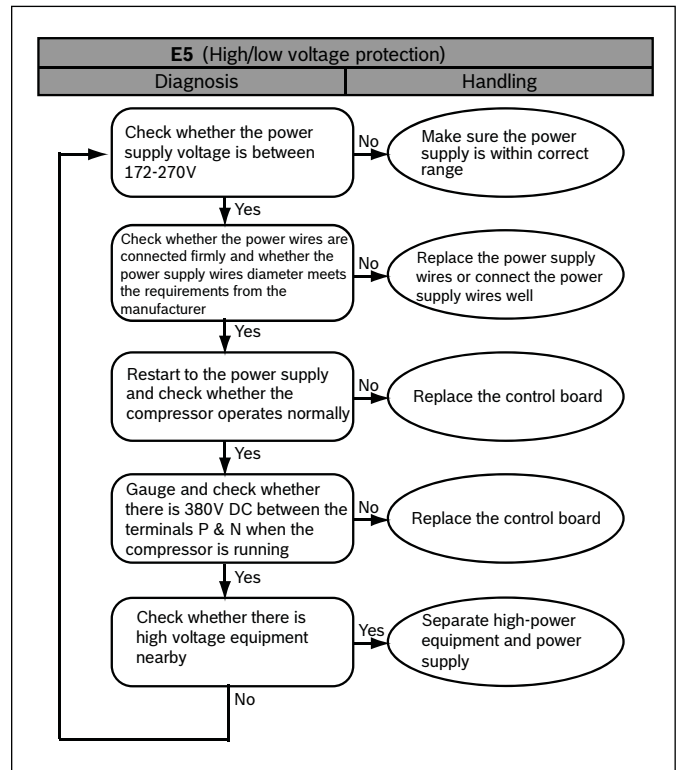

Figure 61

Error Code	Description
L0-L9	IPM module protection

Table 22

When error codes L0-L9 appears occasionally, no action is necessary. The system will restart automatically after 6 minutes.

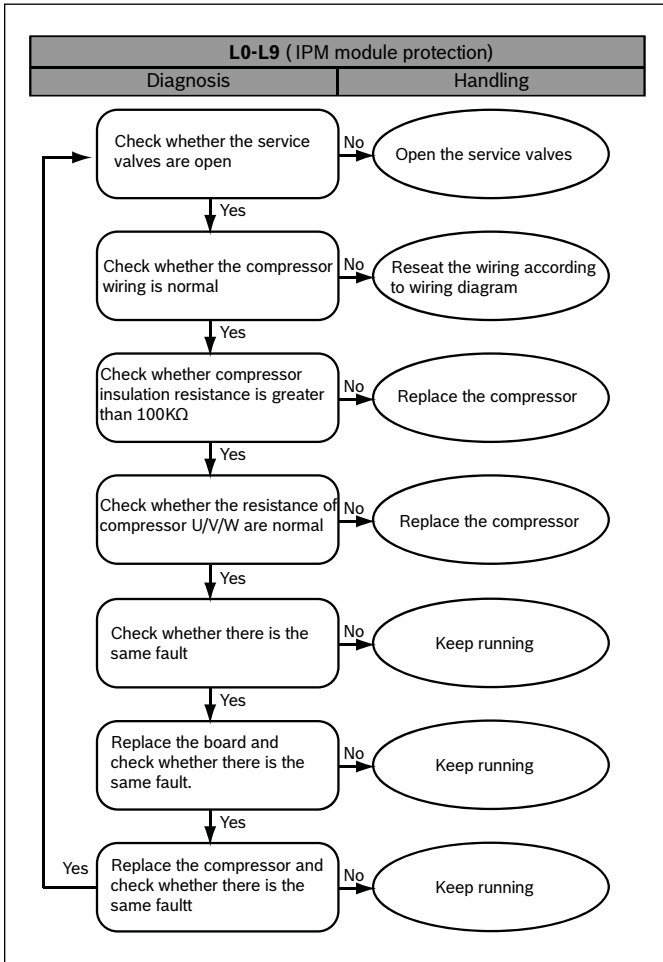

Figure 62

Error Code	Description
AtL	Ambient Temperature Limited

Table 23

i When the ambient temperature returns to within the operating range, the system will recover automatically.

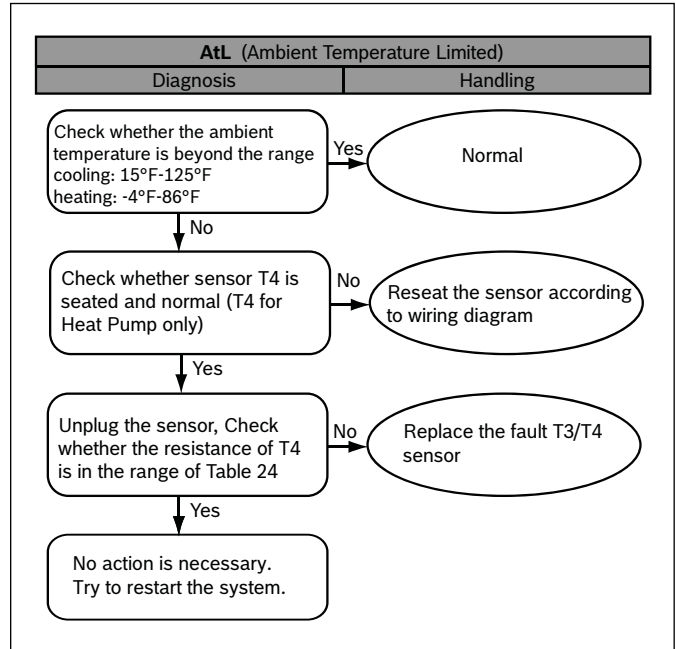

Figure 63

15.12 Temperature and Resistance Relationship Tables (for Sensors)

TEMP F	TEMP C	RESISTANCE kΩ	VOLTS DC	TEMP F	TEMP C	RESISTANCE kΩ	VOLTS DC
-5	-20.6	107.732	4.65	90	32.2	7.225	2.36
0	-17.8	93.535	4.60	95	35.0	6.401	2.21
5	-15.0	79.521	4.54	100	37.8	5.683	2.07
10	-12.2	67.795	4.47	105	40.6	5.057	1.93
15	-9.4	57.948	4.39	110	43.3	4.509	1.79
20	-6.7	49.652	4.30	115	46.1	4.028	1.67
25	-3.9	42.645	4.21	120	48.9	3.606	1.55
30	-1.1	36.710	4.10	125	51.7	3.233	1.43
40	4.4	27.386	3.86	130	54.4	2.902	1.32
45	7.2	23.732	3.73	135	57.2	2.610	1.22
50	10.0	20.610	3.59	140	60.0	2.350	1.13
55	12.8	17.939	3.45	145	62.8	2.119	1.04
60	15.6	15.648	3.30	150	65.6	1.914	0.96
65	18.3	13.681	3.15	155	68.3	1.731	0.88
70	21.1	11.987	2.99	160	71.1	1.574	0.82
75	23.9	10.527	2.83	165	73.9	1.416	0.75
80	26.7	9.265	2.67	170	76.7	1.276	0.68
85	29.4	8.172	2.52				

Table 24 for T3, T4, Th, T3L

15.13 Temperature and Resistance Relationship Tables (for T5 & Tf Sensors)

TEMP F	TEMP C	RESISTANCE kΩ	VOLTS DC	TEMP F	TEMP C	RESISTANCE kΩ	VOLTS DC
-5	-20.6	600.134	4.93	140	60.0	13.643	3.14
0	-17.8	505.551	4.92	145	62.8	12.359	3.03
5	-15.0	427.463	4.91	150	65.6	11.214	2.91
10	-12.2	362.739	4.89	155	68.3	10.227	2.80
15	-9.4	308.891	4.87	160	71.1	9.308	2.68
20	-6.7	265.398	4.85	165	73.9	8.485	2.56
25	-3.9	227.481	4.83	170	76.7	7.746	2.45
30	-1.1	195.601	4.80	175	79.4	7.105	2.34
35	1.7	168.707	4.77	180	82.2	6.504	2.23
40	4.4	146.695	4.74	185	85.0	5.963	2.13
45	7.2	127.258	4.70	190	87.8	5.474	2.02
50	10.0	110.707	4.66	195	90.6	5.032	1.92
55	12.8	96.572	4.61	200	93.3	4.645	1.83
60	15.6	84.465	4.56	205	96.1	4.28	1.73
65	18.3	74.411	4.51	210	98.9	3.949	1.64
70	21.1	65.408	4.45	215	101.7	3.648	1.56
75	23.9	57.634	4.39	220	104.4	3.383	1.48
80	26.7	50.904	4.32	225	107.2	3.133	1.40
85	29.4	45.258	4.24	230	110	2.904	1.32
90	32.2	40.152	4.16	235	112.8	2.694	1.25
95	35.0	35.699	4.08	240	115.6	2.503	1.18
100	37.8	31.807	3.99	245	118.3	2.334	1.12
105	40.6	28.398	3.89	250	121.1	2.172	1.06
110	43.3	25.506	3.80	255	123.9	2.024	1.00
115	46.1	22.861	3.70	260	126.7	1.888	0.95
120	48.9	20.529	3.59	265	129.4	1.767	0.90
125	51.7	18.47	3.48	270	132.2	1.651	0.85
130	54.4	16.708	3.37	275	135.0	1.544	0.80
135	57.2	15.085	3.26	280	137.8	1.446	0.76

Table 25 for T5 & Tf

TEMP F	TEMP C	RESISTANCE kΩ	VOLTS DC	TEMP F	TEMP C	RESISTANCE kΩ	VOLTS DC
-5	-20.6	107.732	4.65	90	32.2	7.225	2.36
0	-17.8	93.535	4.60	95	35.0	6.401	2.21
5	-15.0	79.521	4.54	100	37.8	5.683	2.07
10	-12.2	67.795	4.47	105	40.6	5.057	1.93
15	-9.4	57.948	4.39	110	43.3	4.509	1.79
20	-6.7	49.652	4.30	115	46.1	4.028	1.67
25	-3.9	42.645	4.21	120	48.9	3.606	1.55
30	-1.1	36.710	4.10	125	51.7	3.233	1.43
40	4.4	27.386	3.86	130	54.4	2.902	1.32
45	7.2	23.732	3.73	135	57.2	2.610	1.22
50	10.0	20.610	3.59	140	60.0	2.350	1.13
55	12.8	17.939	3.45	145	62.8	2.119	1.04
60	15.6	15.648	3.30	150	65.6	1.914	0.96
65	18.3	13.681	3.15	155	68.3	1.731	0.88
70	21.1	11.987	2.99	160	71.1	1.574	0.82
75	23.9	10.527	2.83	165	73.9	1.416	0.75
80	26.7	9.265	2.67	170	76.7	1.276	0.68
85	29.4	8.172	2.52				

Table 26

C-cooling H-Heating P-Primary Causes S-Secondary Causes Comp.-compressor RES.-Restrictions REF.-Refrigeration DEF.-Defective CIR.-Circuit EEV-Electronic expansion valve REV.-Reversing Valve
PT-Pressure Transducer T3-Outdoor coil temp. sensor T4-Ambient temp. sensor T5-Comp. discharge temp. sensor Tf-Module radiator fin temp. sensor HPS-High pressure switch
RES I.D. AIRFLOW -Perhaps failure of fan motor or fan capacitor or filter RES O.D. AIRFLOW -Perhaps failure of fan motor or fan capacitor or recirculation or blocking coil RES O.D. RADIATOR-Perhaps failure of blocking radiator

16 Wiring Diagram

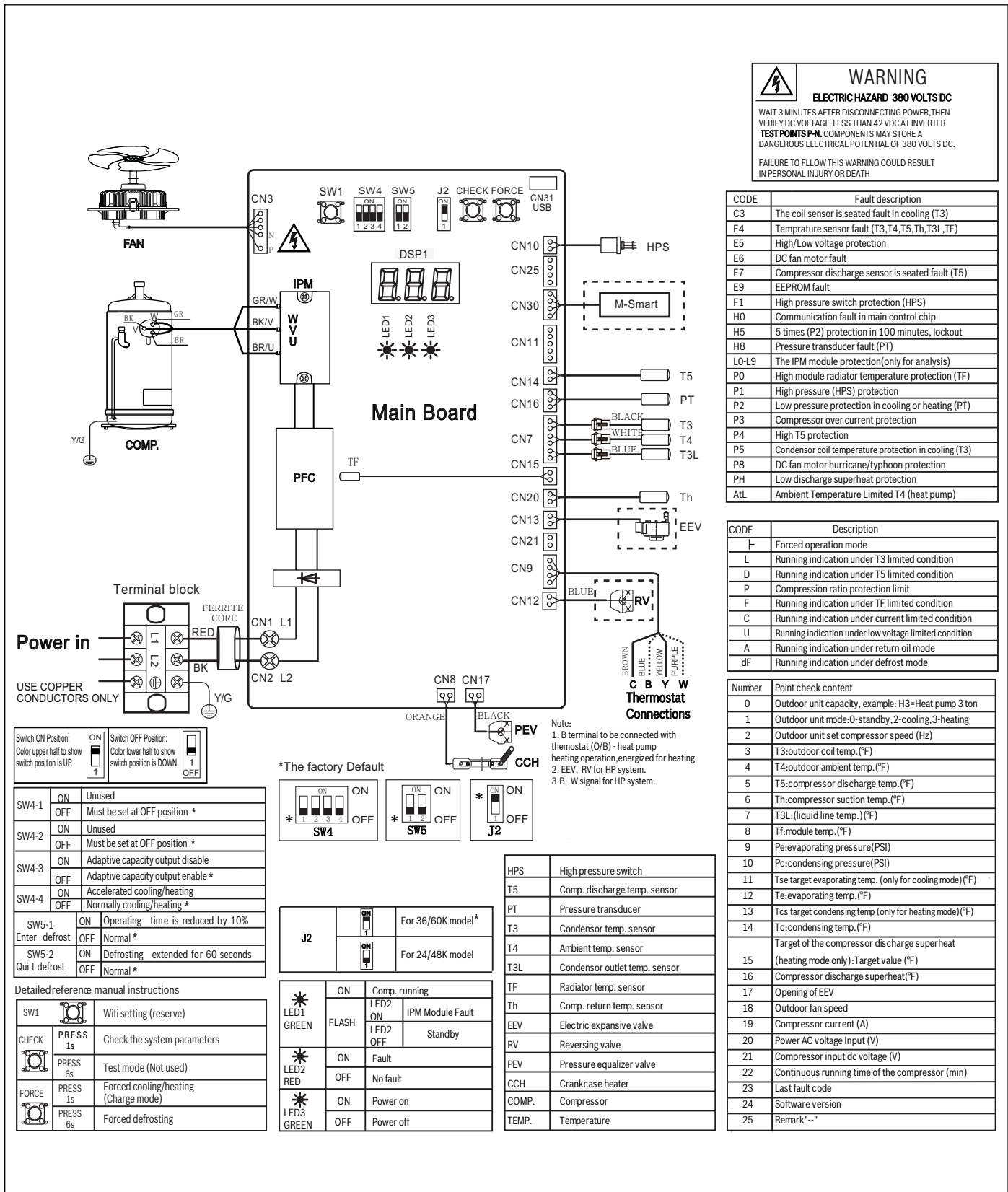

Figure 64

17 Care and Maintenance

17.1 Cleaning Precautions



WARNING:

- ▶ Any maintenance and cleaning of outdoor unit must be performed by qualified service personnel only.
- ▶ Any unit repairs must be performed by qualified service personnel only.



CAUTION: ELECTRIC SHOCK

- ▶ Always turn off your heat pump and disconnect the power supply before cleaning or maintenance.

NOTICE:

- ▶ Do not use chemicals or chemically treated cloths to clean the unit .
- ▶ Do not use benzene, paint thinner, polishing powder or other solvents to clean the unit.



CAUTION:

- ▶ When removing filter, do not touch metal parts in the unit. The sharp metal edges can cut you.

17.2 Maintenance – Pre-Season Inspection

At the beginning of each heating or cooling season, do the following:

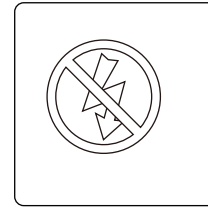

Turn off the unit and disconnect the power

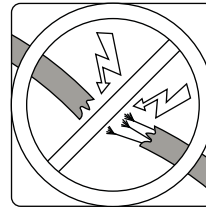

Check for damaged wires



Check for leaks



Make sure nothing is blocking all air inlets and outlets

Figure 65

Notes:

United States and Canada

**Bosch Thermotechnology Corp.
65 Grove St.
Watertown, MA 02472**

**Tel: 866-642-3198
Fax: 954-776-5529
www.boschheatingandcooling.com**

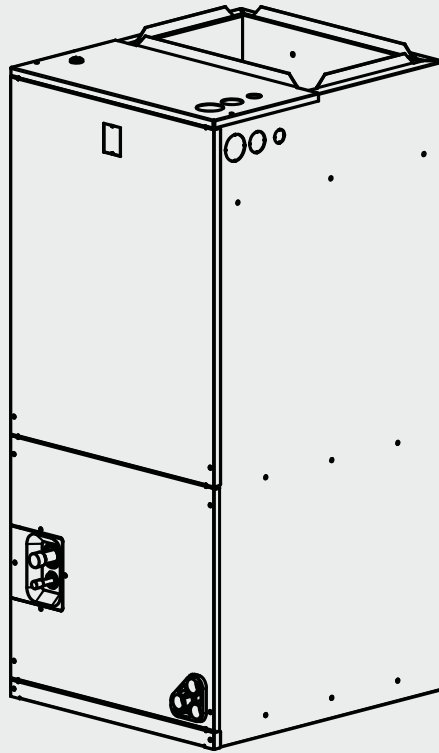

Bosch BVA Series Air Handler

2-3-4-5 Ton Capacity

R410A



BOSCH

Installation Instructions



Table of Contents

1	Key to symbols and safety instructions	4
2	General	6
3	Applications	8
4	Electrical wiring	10
5	Airflow performance	12
6	Ductwork	13
7	Refrigerant connections	14
8	Air filter (not factory-installed)	14
9	Filter installation dimensions	15
10	Wiring diagram	16

1 Key to symbols and safety instructions

1.1 Key to symbols

Warnings



Warnings in this document are identified by a warning triangle printed against a grey background. Keywords at the start of a warning indicate the type and seriousness of the ensuing risk if measures to prevent the risk are not taken.

The following keywords are defined and can be used in this document:

- ▶ **DANGER** indicates a hazardous situation which, if not avoided, will result in death or serious injury.
- ▶ **WARNING** indicates a hazardous situation which, if not avoided, could result in death or serious injury.
- ▶ **CAUTION** indicates a hazardous situation which, if not avoided, could result in minor to moderate injury.
- ▶ **NOTICE** is used to address practices not related to personal injury.

Important information



This symbol indicates important information where there is no risk to people or property.

1.2 Safety

Please read before proceeding



DANGER:

- ▶ These instructions are intended as an aid to qualified licensed service personnel for proper installation, adjustment and operation of this unit. Read these instructions thoroughly before attempting installation or operation. Failure to follow these instruction may result in improper installation, adjustment, service or maintenance possibly resulting in fire, electrical shock, property damage, personal injury or death.



This document is customer property and is to remain with this unit. These instructions do not cover all the different variations of systems nor does it provide for every possible contingency to be met in connection with installation.



CAUTION:

- ▶ All phases of this installation must comply with NATIONAL, STATE AND LOCAL CODES. If additional information is required please contact your local distributor..



WARNING: HAZARDOUS VOLTAGE

- ▶ Disconnect all power to unit before installing or servicing. More than one disconnect switch may be required to deenergize the equipment. Hazardous voltage can cause severe personal injury or death.



WARNING:

- ▶ If removal of the blower assembly is required, all disconnect switches supplying power to the equipment must be deenergized and locked (if not in sight of unit) so the field power wires can be safely removed from the blower assembly. Failure to do so can cause electrical shock resulting in personal injury or death.



WARNING:

- ▶ Because of possible damage to equipment or personal injury, installation, service, and maintenance should be performed by a trained, qualified service personnel. Consumer service is recommended only for filter cleaning / replacement. Never operate the unit with the access panels removed.

**WARNING:**

- ▶ These instructions are intended as an aid to qualified, licensed service personnel for proper installation, adjustment and operation of this unit. Read these instructions thoroughly before attempting installation or operation. Failure to follow these instructions may result in improper installation, adjustment, service or maintenance, possibly resulting in fire, electrical shock, property damage, personal injury or death.

**WARNING: PROPOSITION 65:**

- ▶ This appliance contains fiberglass insulation. Respirable particles of fiberglass are known to State of California to cause cancer.
- ▶ All manufacturer products meet current federal OSHA Guidelines for safety. California Proposition 65 warnings are required for certain products, which are not covered by the OSHA standards.
- ▶ California's Proposition 65 requires warnings for products sold in California that contain or produce any of over 600 listed chemicals known to the State of California to cause cancer or birth defects such as fiberglass insulation, lead in brass, and combustion products from natural gas.
- ▶ All "new equipment" shipped for sale in California will have labels stating that the product contains and /or produces Proposition 65 chemicals. Although we have not changed our processes, having the same label on all our products facilitates manufacturing and shipping. We cannot always know "when, or if" products will be sold in the California market.
- ▶ You may receive inquiries from customers about chemicals found in, or produced by, some of our heating and airconditioning equipment, or found in natural gas used with some of our products. Listed below are those chemicals and substances commonly associated with similar equipment in our industry and other manufacturers.
 - Glass Wool (Fiberglass) Insulation
 - Carbon Monoxide (CO).
 - Formaldehyde
 - Benzene
- ▶ More details are available at the websites for OSHA (Occupational Safety and Health Administration), at www.osha.gov and the State of California's OEHHA (Office of Environmental Health Hazard Assessment), at www.oehha.org. Consumer education is important since the chemicals and substances on the list are found in our daily lives. Most consumers are aware that products present safety and health risks, when improperly used, handled and maintained.

**WARNING:**

- ▶ The unit must be permanently grounded. Failure to do so can result in electrical shock causing personal injury or death.

**WARNING:**

- ▶ The material of Plenum and ductwork must meet the standard NFPA 90B.

**WARNING:**

- ▶ The first 6 inches of supply air plenum and ductwork must be constructed of sheet metal as required by NFPA 90B. The supply air plenum or duct must have a solid sheet metal bottom piece directly after the air handler unit with no openings, registers or flexible air ducts located in it. If flexible supply air ducts are used they may be located only in the side walls of the rectangular plenum, a minimum of 6 inches from the solid bottom. Metal plenum or duct may be connected to the non-combustible floor base for downflow. Exposing combustible non-metal. material to the supply opening of a downflow unit can cause a fire resulting in property damage, personal injury or death.

**CAUTION:**

- ▶ Make sure the blower motor support is tight (3-motor mounting bolts - Fig. 1). Then check to see if wheel is tightly secured to motor shaft before operation unit.

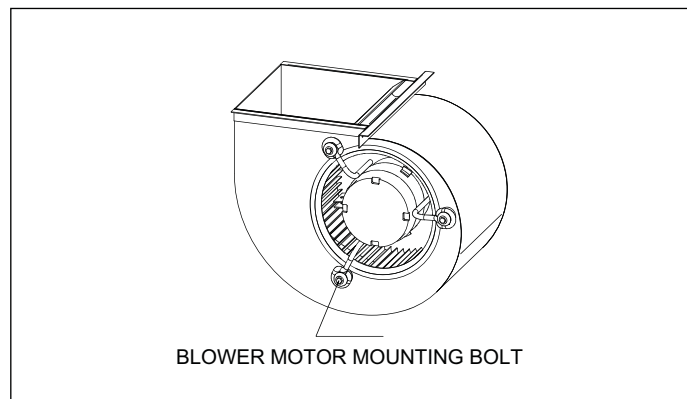

Figure 1

2 General

The unit can be positioned for bottom air return in the upflow position, left and right return in the horizontal position, top return in downflow position.

This Air Handler provides the flexibility for installation in any upflow, downflow or horizontal application. Adjust motor speed tap through DIP switch to select correct air flow according to blower performance table.

Top and side power and control wiring, accessible screw terminals for control wiring all combine to make the installation easy, and minimize installation cost. See fig.3.

To ensure the proper installation, select a solid and level site. Ensure enough space is maintained for installation and maintenance.

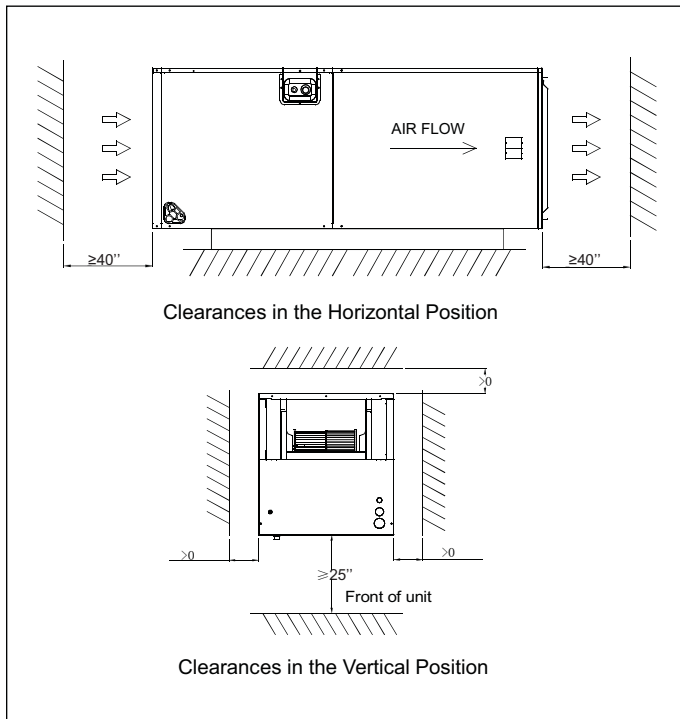

Figure 2

2.1 Unit dimensions

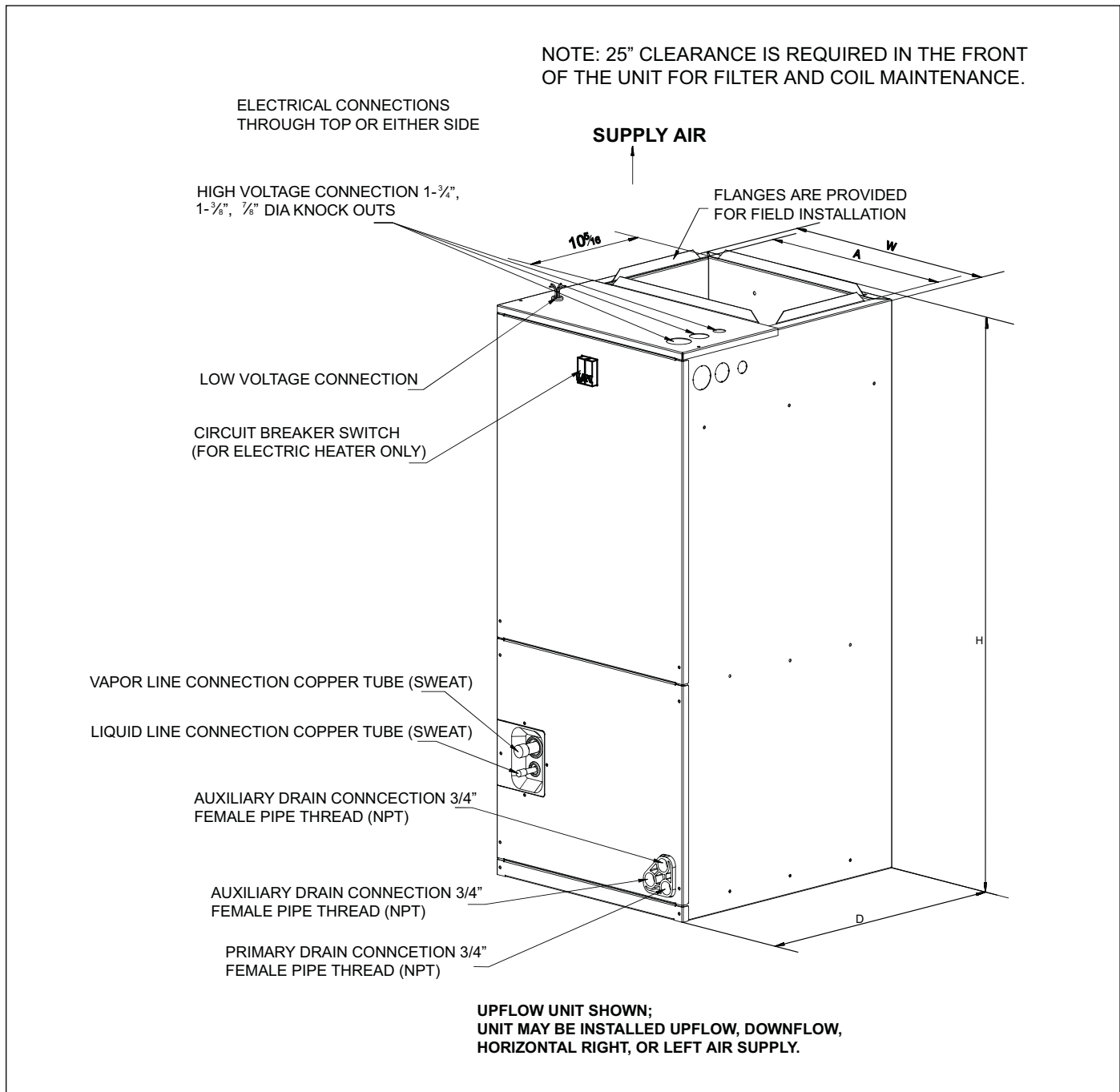

Figure 3

Model Size	Dimensions Inch [mm]				
	Unit Height "H" In. [mm]	Unit Width "W" In. [mm]	Unit Length "D" In. [mm]	Supply Duct "A"	Liquid Line / Vapor Line
24	46-1/2"[1180]	19-5/8"[500]	21-5/8"[550]	18"[456]	3/8" / 3/4" [9.5]/[19]
36	46-1/2"[1180]	19-5/8"[500]	21-5/8"[550]	18"[456]	3/8" / 3/4" [9.5]/[19]
48	54-1/2"[1385]	22"[560]	24"[610]	19-1/2"[496]	3/8" / 7/8" [9.5]/[22]
60	54-1/2"[1385]	22"[560]	24"[610]	19-1/2"[496]	3/8" / 7/8" [9.5]/[22]

Table 1

3 Applications

3.1 Vertical upflow

- ▶ Vertical Upflow configuration is the factory default on all models (see Fig 3).
- ▶ If return air is to be ducted, install duct flush with floor. Use fireproof resilient gasket 1/8 to 1/4 in. thick between the ducts, unit and floor. Set unit on floor over opening.



Lightly tighten the drain connections so they do not leak. Using excessive force may/will cause damage to the unit. (see Fig.3&4)

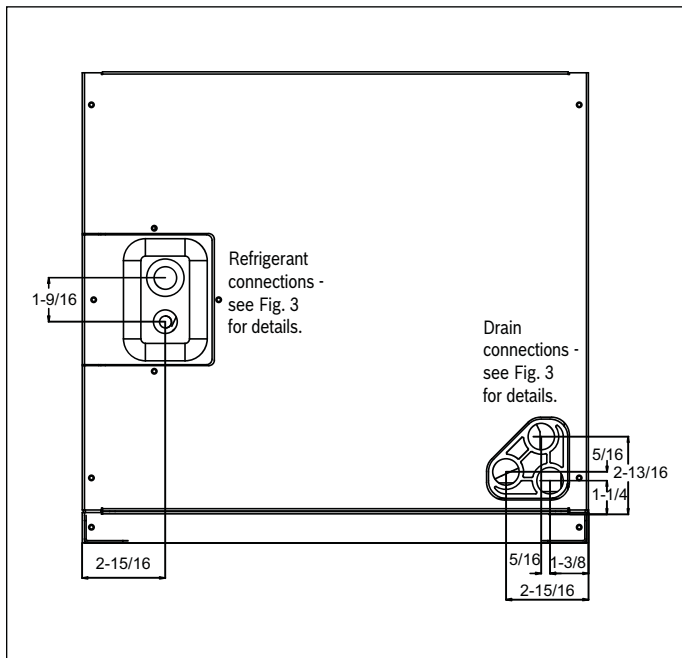

Figure 4 Dimensions for front connect coil

3.2 Vertical downflow

Conversion to Vertical Downflow:

A vertical upflow unit may be converted to vertical downflow. Remove the door and indoor coil and reinstall 180° from original position. See Fig 5.



To comply with Safety Standards and the National Electric Code for downflow application, the circuit breaker(s) on field installed electric heater kits refer to electric heater kit installation manual for more detail. The breaker switch “on” position and marking are up and, “off” position and marking are down.



CAUTION:

- ▶ When using the unit with electric heater kits, the switch on the front of panel is used for these heaters only.

3.3 Horizontal

Horizontal right is the default factory configuration for the units. Conversion to Horizontal left: A vertical upflow unit may be converted to horizontal left by removing indoor coil assembly and reinstalling coil as shown for left hand air supply.

- ▶ Rotate the unit 90° into the horizontal left position, with the coil compartment on the right and the blower compartment on the left. See Fig. 5.
- ▶ Reinstall the indoor coil 180° from original position. Ensure the retaining channel is fully engaged with the coil rail. See Fig. 5.
- ▶ Secondary drain pan kits are recommended when the unit is configured for the horizontal position over a finished ceiling and/or living space.

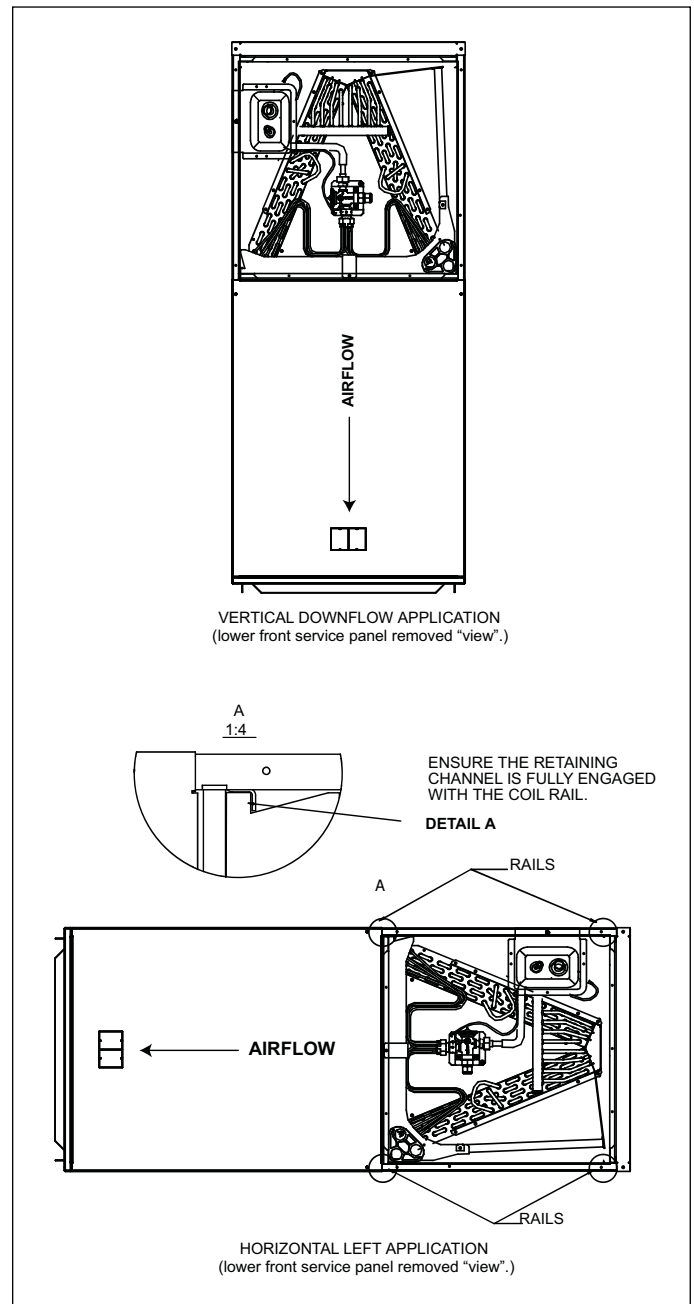

Figure 5

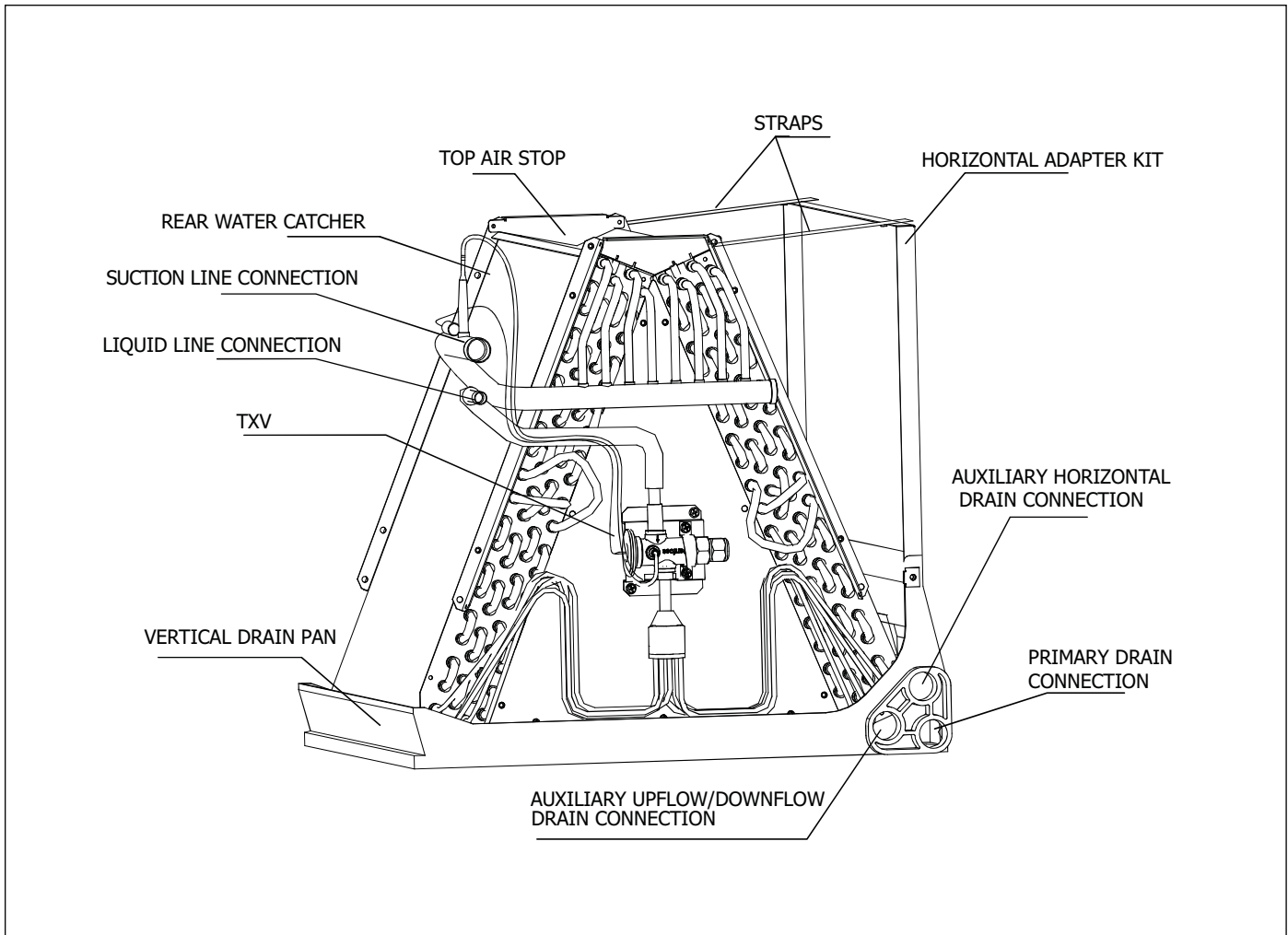

Figure 6

**CAUTION:**

- ▶ Horizontal units must be configured for right hand air supply or left hand air supply. Horizontal drain pan must be located under indoor coil. Failure to use the drain pan can result in property damage.

3.4 Installation in an unconditioned space



There are two pairs of coil rails in the air handler for default and counter flow application. If the air handler is installed in an unconditioned space, the two unused coil rails should be removed to minimize air handler surface sweating. The coil rails can be easily removed by taking off the 6 mounting screws from both sides of the cabinet.

4 Electrical wiring

Field wiring must comply with the National Electric Code (C.E.C. in Canada) and any applicable local ordinance.



WARNING: HAZARDOUS VOLTAGE

- ▶ Disconnect all power to unit before installing or servicing. More than one disconnect switch may be required to deenergize the equipment. Hazardous voltage can cause severe personal injury or death.

4.1 Power wiring

It is important that proper electrical power is available for connection to the unit being installed. See the unit nameplate, wiring diagram and electrical data in the installation instructions.

- ▶ If required, install a branch circuit disconnect of adequate size, located within sight of, and readily accessible from the unit.



When the Electric Heater is installed, units may be equipped with one or two 30-60 amp. circuit breakers. These breaker(s) protect the internal wiring in the event of a short circuit and serve as a disconnect. Circuit breakers installed within the unit do not provide over-current protection of the supply wiring and therefore may be sized larger than the branch circuit protection.

- ▶ Supply circuit power wiring must be 75°C minimum copper conductors only. See Electrical Data In this section for ampacity, wire size and circuit protector requirement. Supply circuit protective devices may be either fuses or "HACR" type circuit breakers.

4.2 Control wiring



Class 2 low voltage control wiring should not be run in conduit with main power wiring and must be separated from power wiring, unless class 1 wire of proper voltage rating is used.

- ▶ Low voltage control wiring should be 18 Awg. color-coded. For lengths longer than 100 ft., 16 Awg. wire should be used.
- ▶ Low voltage control connections are made to low voltage pigtails within air handler control box.
- ▶ See wiring diagrams attached to indoor and outdoor sections to be connected.
- ▶ Make sure, after installation, separation of control wiring and power wiring has been maintained.

4.3 Grounding



WARNING:

- ▶ The unit must be permanently grounded. Failure to do so can result in electrical shock causing personal injury or death.

- ▶ Grounding may be accomplished by grounding metal conduit when installed in accordance with electrical codes to the unit cabinet.
- ▶ Grounding may also be accomplished by attaching ground wire(s) to ground lug(s) provided in the unit wiring compartment.
- ▶ Use of multiple supply circuits require grounding of each circuit to lug(s) provided in unit.

4.4 Electrical data

Model	Voltage	Hertz	HP	Speeds	Circuit Amps	Maximum Circuit Protector
24	208/230	60	1/3	5	3.5	15(A)
36	208/230	60	1/2	5	5.1	15(A)
48	208/230	60	3/4	5	7.5	15(A)
60	208/230	60	3/4	5	7.5	15(A)

Table 2

4.5 Electrical kit MCA/MOP data

Heat Kit Model	Air Handler Model	(kW)Electric Heat	MIN. Circuit Ampacity		MAX. Fuse or Breaker (HACR) Ampacity		Fan Speed				
			240 VAC	208 VAC	240 VAC	208 VAC	1	2	3	4	5
EHK-05B	24	5	28.5	24.9	30	25	•	•	•	•	•
EHK-08B		7.5	41.5	36.3	45	40	X	X	•	•	•
EHK-10B		10	54.5	47.6	60	50	X	X	•	•	•
EHK-05B	36	5	29.7	26.2	30	30	•	•	•	•	•
EHK-08B		7.5	42.7	37.5	45	40	X	•	•	•	•
EHK-10B		10	55.8	48.8	60	50	X	X	•	•	•
EHK-15B	48	15	55.8+26.1	48.8+22.6	60+30	50+25	X	X	•	•	•
			81.8*	75.3*	90*	80*					
EHK-05B	48	5	33.6	30.1	35	35	•	•	•	•	•
EHK-08B		7.5	46.6	41.4	50	45	•	•	•	•	•
EHK-10B		10	59.6	52.7	60	60	X	•	•	•	•
EHK-15B		15	59.6+26.1	52.7+22.6	60+30	60+25	X	X	•	•	•
			85.7*	75.3*	90*	80*					
EHK-20B	20	59.6+52.1	52.7+45.2	60+60	60+50	X	X	X	•	•	
		111.7*	97.8*	125*	100*						
EHK-05B	60	5	33.6	30.1	35	35	X	X	•	•	•
EHK-08B		7.5	46.6	41.4	50	45	X	X	•	•	•
EHK-10B		10	59.6	52.7	60	60	X	X	•	•	•
EHK-15B		15	59.6+26.1	52.7+22.6	60+30	60+25	X	X	•	•	•
			85.7*	75.3*	90*	80*					
EHK-20B	20	59.6+52.1	52.7+45.2	60+60	60+50	X	X	X	•	•	
		111.7*	97.8*	125*	100*						

Table 3

Heat kit suitable for AHU multi position installation.

[• means available, X means not available, * means single circuit]

Heater Kit Accessories

Model	Description	24	36	48	60
EHK-05B	5kW Heat Kit, Double Pole Breaker	•	•	•	•
EHK-08B	7.5kW Heat Kit, Double Pole Breaker	•	•	•	•
EHK-10B	10kW Heat Kit, Double Pole Breaker	•	•	•	•
EHK-15B	15kW Heat Kit, Double Pole Breaker	X	•	•	•
EHK-20B	20kW Heat Kit, Double Pole Breaker	X	X	•	•

Table 4

[• means available, X means not available]

5 Airflow performance

Airflow performance data is based on cooling performance with a coil and no filter in place. Check the performance table for appropriate unit size selection. External static pressure should stay within the minimum and maximum limits shown in the table below in order to ensure proper operation of both cooling, heating, and electric heating operation.

Air Handler Model Size	Motor Speed		SCFM									
			External Static Pressure-Inches W.C. [kPa]									
				0.1[.02]	0.2[.05]	0.3[.07]	0.4[.10]	0.5[.12]	0.6[.15]	0.7[.17]	0.8[.20]	
24	Tap(5)	SCFM	1016	955	914	870	827	790	741	691	657	
		Watts	139	146	157	165	174	185	195	202	209	
	Tap(4)	SCFM	955	892	853	804	768	729	671	630	---	
		Watts	118	125	135	142	152	162	169	178	---	
	Tap(3) -Default Setting	SCFM	927	829	789	739	701	643	597	---	---	
		Watts	109	105	113	121	131	137	147	---	---	
	Tap(2)	SCFM	887	766	671	631	567	522	465	---	---	
		Watts	97	87	83	93	99	108	112	---	---	
	Tap(1)	SCFM	829	698	547	366	347	277	234	---	---	
		Watts	81	71	60	54	60	64	72	---	---	
	36	Tap(5)	SCFM	1452	1403	1343	1287	1214	1144	1085	1022	968
			Watts	253	264	271	284	296	303	313	324	329
Tap(4) -Default Setting		SCFM	1255	1203	1150	1062	995	920	854	797	719	
		Watts	170	182	193	201	212	221	229	239	244	
Tap(3)		SCFM	1109	1050	985	897	841	841	766	702	617	
		Watts	126	136	147	154	164	170	180	187	195	
Tap(2)		SCFM	1020	907	818	733	673	586	520	---	---	
		Watts	103	98	109	114	124	129	139	---	---	
Tap(1)		SCFM	962	807	627	551	450	380	296	---	---	
		Watts	90	80	71	79	83	93	96	---	---	
48		Tap(5)	SCFM	2072	2013	1935	1923	1878	1830	1783	1736	1688
			Watts	447	464	489	497	514	530	545	558	570
	Tap(4)	SCFM	1860	1816	1735	1679	1640	1591	1542	1504	1481	
		Watts	348	364	383	395	408	418	429	451	463	
	Tap(3) -Default Setting	SCFM	1702	1651	1560	1547	1497	1438	1385	1331	1280	
		Watts	268	281	304	312	325	337	349	361	375	
	Tap(2)	SCFM	1393	1358	1179	1155	1139	1074	1020	964	896	
		Watts	227	234	258	269	270	283	296	313	325	
	Tap(1)	SCFM	1365	1239	1078	1050	965	904	886	831	797	
		Watts	220	226	243	264	269	281	293	301	317	
	60	Tap(5)	SCFM	2054	2015	1947	1928	1886	1846	1804	1742	1654
			Watts	470	495	518	528	542	553	569	567	548
Tap(4) -Default Setting		SCFM	1883	1840	1783	1754	1712	1670	1622	1579	1541	
		Watts	367	388	411	420	422	445	454	466	479	
Tap(3)		SCFM	1721	1674	1582	1566	1528	1484	1443	1401	1345	
		Watts	289	305	327	330	341	353	365	378	387	
Tap(2)		SCFM	1515	1463	1386	1358	1308	1262	1215	1153	1073	
		Watts	205	218	235	239	251	263	276	285	301	
Tap(1)		SCFM	1337	1265	1156	1148	1095	984	955	963	789	
		Watts	145	157	173	178	186	197	212	225	235	

Table 5

- Bold outlined areas represent airflow outside of the required 300-450 cfm/ton range.



SCFM means Standard Cubic Foot per Minute.



Airflow based upon Air Handler Unit operating at 230V with no electric heater kit and no filter. Airflow at 208V is approximately the same as 230V.

The air distribution system has the greatest effect on airflow. The duct system is totally controlled by the contractor. For this reason, the contractor should use only industry-recognized procedures.

Heat pump systems require a specified airflow. Each ton of cooling requires between 350 and 450 cubic feet of air per minute (CFM), or 400 CFM nominally. Duct design and construction should be carefully done. System performance can be lowered dramatically through bad planning or workmanship.

Air supply diffusers must be selected and located carefully. They must be sized and positioned to deliver treated air along the perimeter of the space. If they are too small for their intended airflow, they become noisy. If they are not located properly, they cause drafts. Return air grilles must be properly sized to carry air back to the blower. If they are too small, they also cause noise.

The installers should balance the air distribution system to ensure proper quiet airflow to all rooms in the home. This ensures a comfortable living space. An air velocity meter or airflow hood can be used to balance and verify branch and system airflow (CFM).

6 Ductwork

Field ductwork must comply with the National Fire Protection Association NFPA 90A, NFPA 90B and any applicable local ordinance.



WARNING:

- ▶ Do not, under any circumstances, connect return ductwork to any other heat producing device such as fireplace insert, stove, etc. Unauthorized use of such devices may result in fire, carbon monoxide poisoning, explosion, personal injury or property damage.

Sheet metal ductwork run in unconditioned spaces must be insulated and covered with a vapor barrier. Fibrous ductwork may be used if constructed and installed in accordance with SMACNA Construction Standard on Fibrous Glass Ducts. Ductwork must comply with National Fire Protection Association as tested by U/L Standard 181 for Class I Air Ducts. Check local codes for requirements on ductwork and insulation.

- ▶ Duct system must be designed within the range of external static pressure the unit is designed to operate against. It is important that the system airflow be adequate. Make sure supply and return ductwork, grills, special filters, accessories, etc. are accounted for in total resistance. See airflow performance tables in this manual.
- ▶ Design the duct system in accordance with "ACCA" Manual "D" Design for Residential Winter and Summer Air Conditioning and Equipment Selection. Latest editions are available from: "ACCA" Air Conditioning Contractors of America, 1513 16th Street, N.W., Washington, D.C. 20036. If duct system incorporates flexible air duct, be sure pressure drop information (straight length plus all turns) shown in "ACCA" Manual "D" is accounted for in system.
- ▶ Supply plenum should be attached to the 3/4" duct flanges supplied with the unit. Attach flanges around the blower outlet.



If an elbow is included in the plenum close to the unit, it must not be smaller than the dimensions of the supply duct flange on the unit.



The front flange on the return duct if connected to the blower casing must not be screwed into the area where the power wiring is located. Drills or sharp screw points can damage insulation on wires located inside unit.

- ▶ Secure the supply and return ductwork to the unit flanges, using proper fasteners for the type of duct used and tape the duct-to-unit joint as required to prevent air leaks.

7 Refrigerant connections

Keep the coil connections sealed until refrigerant connections are made. See the Installation Instructions for the outdoor unit for details on line sizing, tubing installation, and charging information.

Coil is shipped filled with Nitrogen. Evacuate the system before charging with refrigerant.

Install refrigerant lines so that it does not block service access to the front of the unit. Nitrogen should flow through the refrigerant lines while brazing.

Use a wet rag or an approved heat paste to protect the TXV sensing bulb during the brazing process.

After the refrigerant line connections are made, seal the gap around the connections with pressure sensitive gasket.

7.1 Condensate drain connection

Consult local codes for specific requirements.

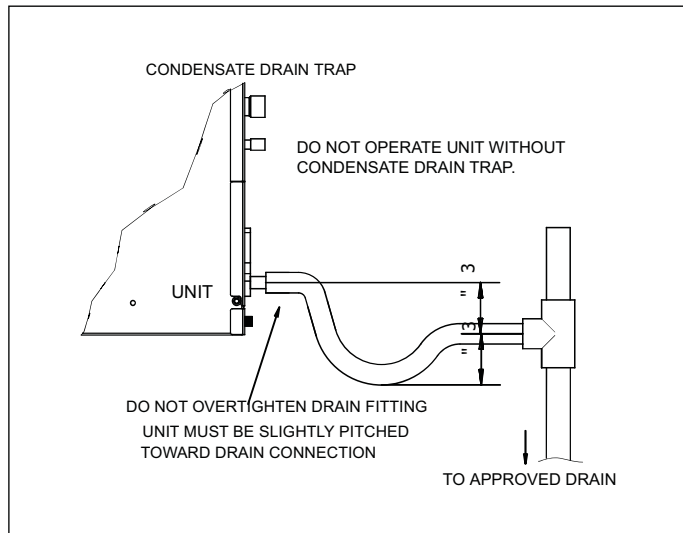

Figure 7

- i** 1. When making drain fitting connections to the drain pan, use a thin layer of Teflon paste, silicone or Teflon tape and install, hand tighten.
2. When making drain fitting connections to drain pan, do not overtighten. Over tightening fittings can split pipe connections on the drain pan.

- ▶ Install drain lines so they do not block service access to front of the unit. Minimum clearance of 24 inches is required for filter, coil or blower removal and service access.
- ▶ Make sure unit is leveled or pitched slightly toward primary drain connection so that water will drain completely from the pan. (See Fig. 7)
- ▶ Do not reduce drain line size to less than connection size provided on condensate drain pan.
- ▶ All horizontal drain lines must be pitched downward away from the unit a minimum of 1/8" per foot of line to ensure proper drainage.

- ▶ Do not connect condensate drain line to a closed or open sewer pipe. Run condensate to an open drain or run line to a safe outdoor area.
- ▶ The drain line should be insulated where necessary to prevent sweating and damage due to condensate forming on the outside surface of the line.
- ▶ Make provisions for disconnecting and cleaning of the primary drain line should it become necessary. Install a 3 inch trap in the primary drain line as close to the unit as possible. Make sure that the top of the trap is below connection to the drain pan to allow complete drainage of pan (See Fig. 7).
- ▶ Auxiliary drain line should be run to a place where condensate will be noticeable. Homeowner should be warned that a problem exists if water should begin running from the auxiliary drain line.
- ▶ Plug the unused drain connection with the plugs provided in the parts bag, using a thin layer of teflon paste, silicone or teflon tape to form a water tight seal.
- ▶ Test condensate drain pan and drain line after installation is complete. Pour water into drain pan, enough to fill drain trap and line. Check to make sure drain pan is draining completely, no leaks are found in drain line fittings, and water is draining from the termination of the primary drain line.

8 Air filter (not factory-installed)

An external filter or other means of filtration must be properly sized for a maximum of 300 feet/min. air velocity or what is recommended for the type filter installed.

Filter application and placement are critical to airflow, which may affect the heating and cooling system performance. Reduced airflow can shorten the life of the system's major components, such as motor, elements, heat relays, evaporator coil or compressor. Consequently, we recommend that the return air duct system have only one filter location. For systems without a return air filter grill, multiple filter grills can be installed at each of the return air openings.

If adding high efficiency filters or electronic air filtration systems, it is very important that the air flow is not reduced. If air flow is reduced the overall performance and efficiency of the unit will be reduced. It is strongly recommended that a professional installation technician is contacted to ensure such filtration systems are installed correctly.

- i** Do not double filter the return air duct system. Do not filter the supply air duct system. This will change the performance of the unit and reduce airflow.



WARNING:

- ▶ Do not operate the system without filters. A portion of the dust suspended in the air may temporarily lodge in the duct runs and at the supply registers. Any circulated dust particles could be heated and charred by contact with the air handler elements. This residue could soil ceilings, walls, drapes, carpets and other articles in the house. Soot damage may occur with filters in place, when certain types of candles, oil lamps or standing pilots are burned.

9 Filter installation dimensions

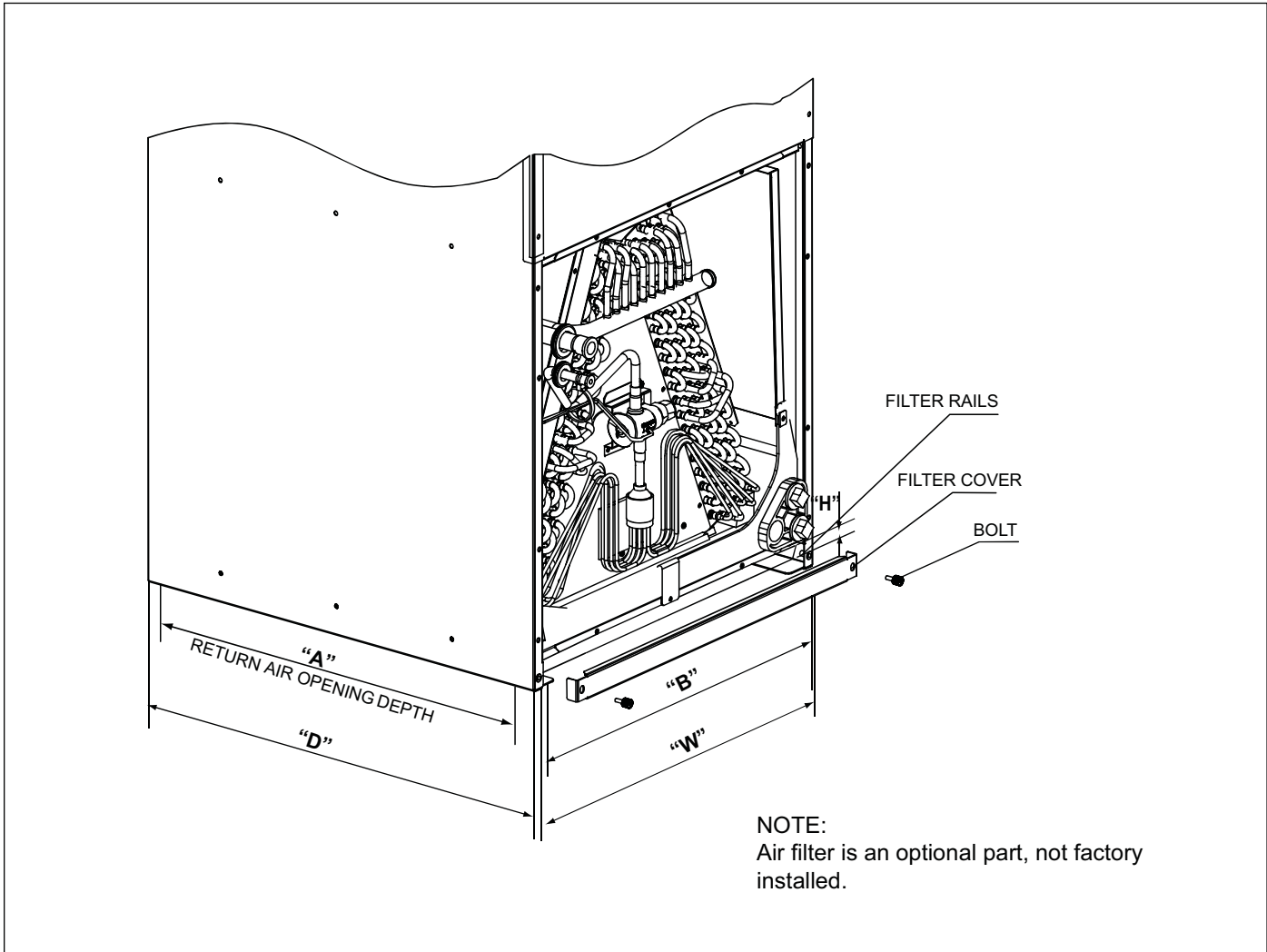

Figure 8

Dimensional data

Model	Filter Size IN [mm]"	"W" IN [mm]	"D" IN [mm]	"H" IN [mm]	Return width "A" IN	Return length "B" IN
24/36	18X20[457X508]	18.3[466]	21.6[548]	1[25.4]	20.8	16.3
48/60	20X22[508X559]	20.7[526]	23.9[608]	1[25.4]	23	18.8

Table 6

Air filter removal / installation

- ▶ Remove bolts manually, remove air filter cover, see Fig. 6;
- ▶ Hold the edge of the air filter and extract out .
- ▶ Install new filter so that the arrow on the filter is in the same direction as airflow.

10 Wiring diagram



WARNING: HIGH VOLTAGE!

- ▶ Disconnect all power before servicing or installing this unit. Multiple power sources may be present. Failure to do so may cause property damage, personal injury or death.

- ▶ To avoid the electrical shock, please ensure the air conditioner is properly grounded. The main power plug in the air conditioner has been joined with the ground wiring, please do not alter.
- ▶ Do not strain the power wiring.

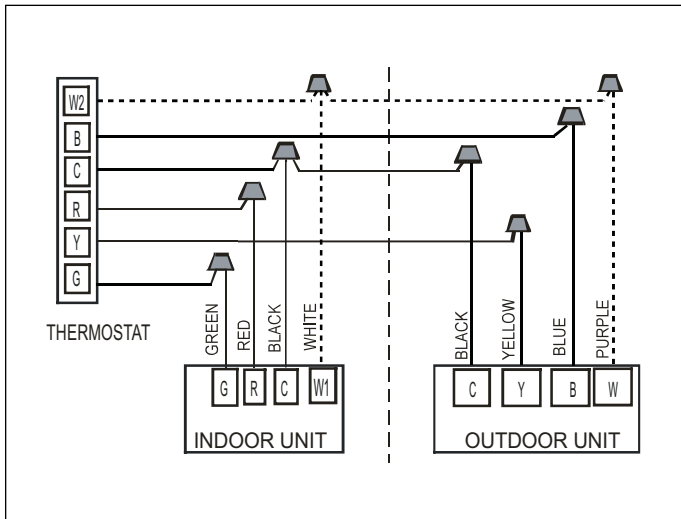

Figure 9 Control Wiring for H/P systems



Broken lines means H/P system with electric heating. Thermostat Wiring please refer to the Owner's Manual of the thermostat.

- ▶ When connecting the air conditioner with the ground, observe the local codes.
- ▶ If necessary, connect wiring to the power fuse or circuit breaker.

Electric wiring gauge for H/P systems

		Model(Btu/h)	24	36	48	60
Power		Phase	Single			
		Voltage/frequency	208/230VAC, 60Hz			
Line Gauge	Input Current Fuse	Indoor unit (A)	15A	15A	15A	15A
	Indoor Unit Power Line	Line Quantity	3	3	3	3
		Line Diameter(AWG)	14	14	14	14
	Outdoor Unit Power Line	Line Quantity	3	3	3	3
		Line Diameter(AWG)	14	12	10	10
	Outdoor-Indoor Signal Line	Line Quantity	4	4	4	4
Line Diameter(AWG)		18	18	18	18	
Thermostat Signal Line	Line Quantity	5	5	5	5	
	Line Diameter(AWG)	18	18	18	18	

Table 7



If indoor unit has auxiliary heating already installed and a different auxiliary heating unit is required, the indoor unit (A) and indoor line diameters will be different.



WARNING:

- ▶ These units must be wired and installed in accordance with all National and Local Safety Codes.

For ECM Motor (Size 24/48K)

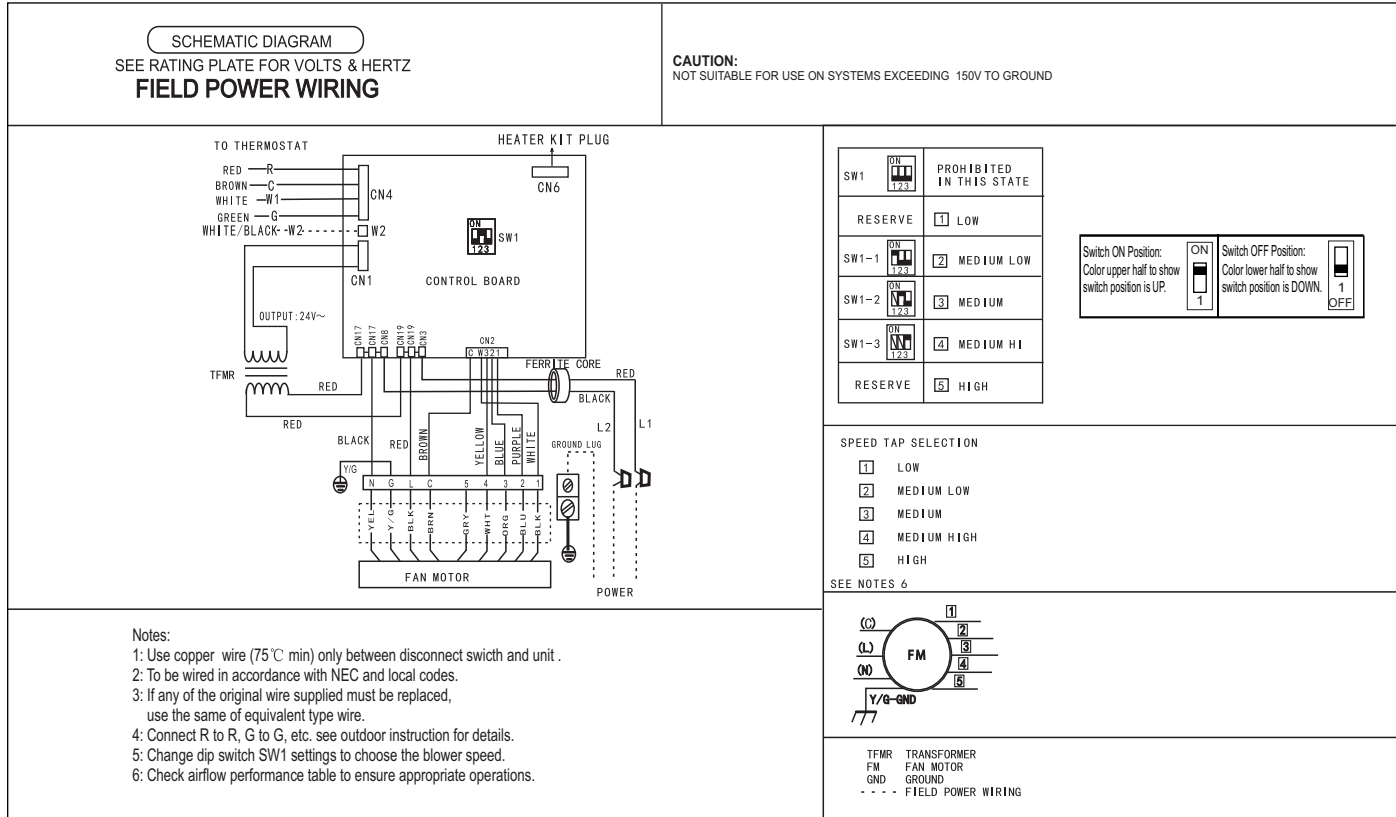

Figure 10

For ECM Motor (Size 36/60K)

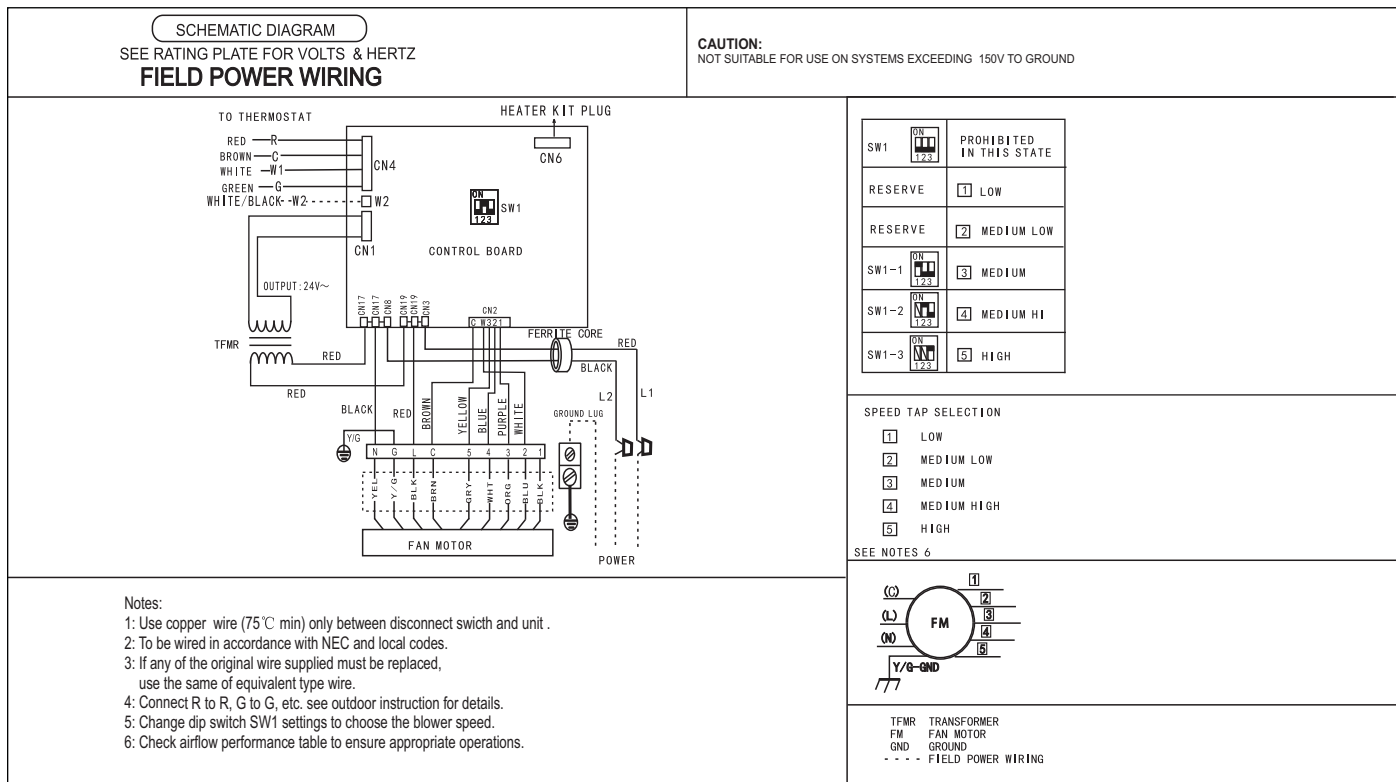

Figure 11

Unit Wiring

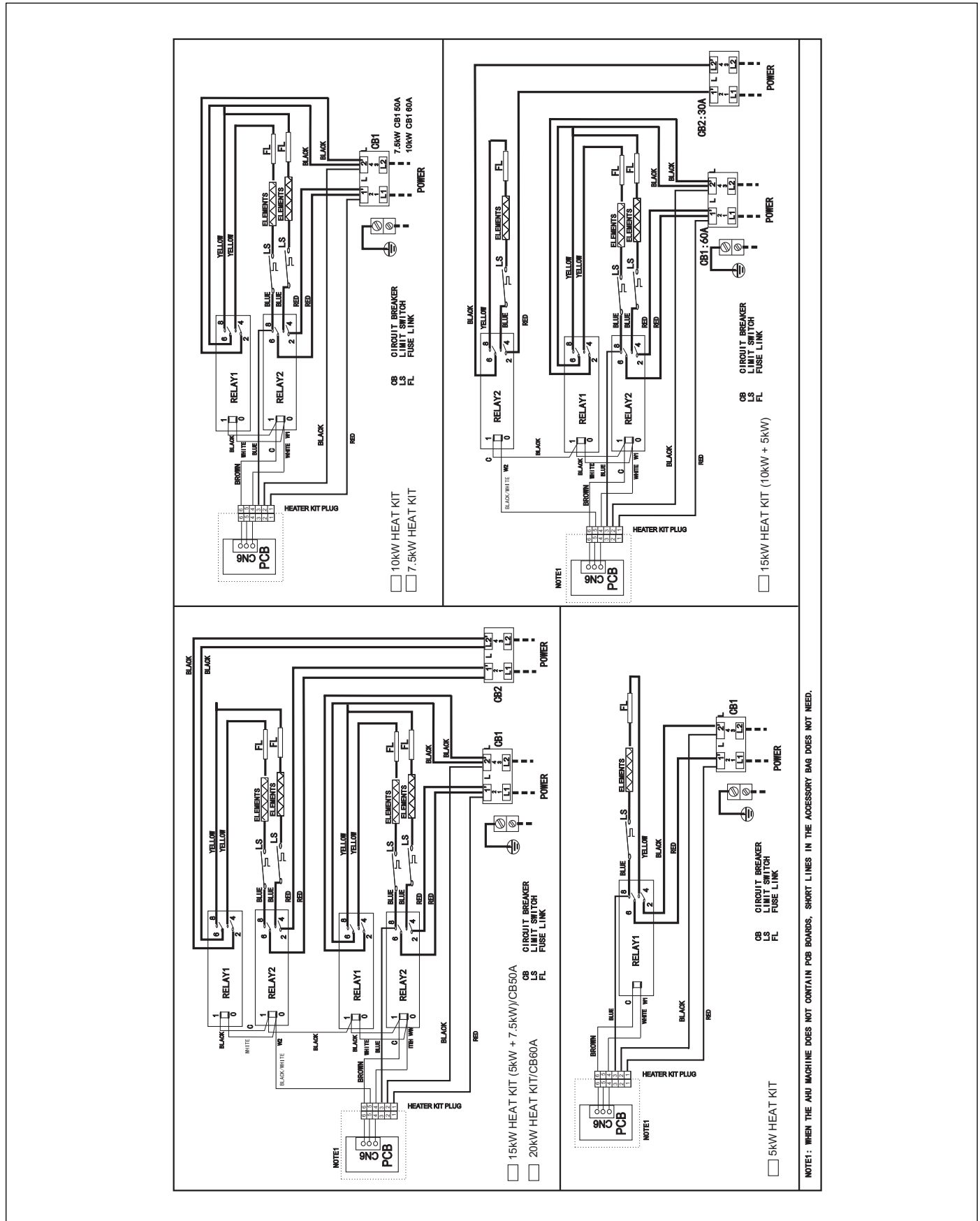

Figure 12

United States and Canada

**Bosch Thermotechnology Corp.
65 Grove Street
Watertown, MA 02472**

**Tel: 866-642-3198
Fax: 603-965-7581
www.boschheatingandcooling.com**