

# Bosch Inverter Ducted Packaged Heat Pump

18.5 SEER Series (3 Ton Capacity)  
R410A



**BOSCH**

## Installation & Operation Manual





## Table of Contents

<b>1 Key to Symbols and Safety Instructions</b>	<b>4</b>	<b>13 System Operation and Troubleshooting</b>	<b>22</b>
1.1 Key to Symbols	4	13.1 Control Logic Description	22
1.2 Safety	4	13.2 Sensors (Thermistors/Pressure Transducer)	22
<b>2 Component Location</b>	<b>6</b>	13.3 Defrost Description	23
<b>3 Dimensions</b>	<b>7</b>	13.4 Compressor Crankcase Heater Description	23
3.1 Unit Dimensions	7	13.5 Reversing Valve Operation	23
3.2 Dimensions - Back and Bottom	8	13.6 Protection Functions	24
3.3 Dimensions - Left and Top	9	13.7 Fault Code Table	25
<b>4 Installation</b>	<b>10</b>	13.8 Parameter Point Check Table	26
4.1 Pre-Installation	10	13.9 Control Board Overview	27
4.2 Rigging and Lifting	10	13.10 Error Code Troubleshooting (ODU)	29
4.3 Location Restrictions	10	13.11 Error Code Troubleshooting (IDU)	35
4.4 Rooftop Installation - Curb Mounting	12	13.12 Temperature and Resistance Relationship Tables (for Sensors)	36
<b>5 Airflow Performance</b>	<b>13</b>	13.13 Temperature and Resistance Relationship Tables (for T5)	37
<b>6 Indoor Fan Motor Function</b>	<b>14</b>	13.14 Wiring Diagram	38
<b>7 Ductwork</b>	<b>15</b>	<b>14 Maintenance</b>	<b>39</b>
<b>8 Condensate Drain Connection</b>	<b>16</b>	14.1 Cleaning Precautions	39
8.1 Install Drain Pipe	16	14.2 Regular Maintenance	39
<b>9 Air Filter (Not Factory-Installed)</b>	<b>16</b>		
<b>10 Electrical Wiring</b>	<b>17</b>		
10.1 Power Wiring	17		
10.2 Grounding	17		
10.3 Control Wiring	17		
<b>11 Start Up</b>	<b>19</b>		
11.1 System Start Up	19		
<b>12 System Charge Adjustment</b>	<b>20</b>		
12.1 Charging: Weigh-In Method	20		
12.2 Subcooling Charging and Refrigerant Adjustment In Cooling (Above 55°F Outdoor Temp.)	20		

## 1 Key to Symbols and Safety Instructions

### 1.1 Key to Symbols

#### Warnings



Warnings in this document are identified by a warning triangle printed against a grey background. Keywords at the start of a warning indicate the type and seriousness of the ensuing risk if measures to prevent the risk are not taken.

The following keywords are defined and can be used in this document:

- ▶ **DANGER** indicates a hazardous situation which, if not avoided, will result in death or serious injury.
- ▶ **WARNING** indicates a hazardous situation which, if not avoided, could result in death or serious injury.
- ▶ **CAUTION** indicates a hazardous situation which, if not avoided, could result in minor to moderate injury.
- ▶ **NOTICE** is used to address practices not related to personal injury.

#### Important information



This symbol indicates important information where there is no risk to people or property.

## 1.2 Safety

### Please read before proceeding



This document contains a wiring diagram and service information. This is customer property and is to remain with this unit. Please return to service information pack upon completion of work.



#### **WARNING: HIGH VOLTAGE**

- ▶ Failure to follow this warning could result in property damage, severe personal injury, or death.
- ▶ **WAIT THREE (3) MINUTES** after disconnecting power prior to touching electrical components as they may hold a dangerous charge of 380 VDC, then verify DC Voltage is less than 42VDC at inverter TEST POINTS P-N.

#### **NOTICE:**

- ▶ This document is customer property and is to remain with this unit. Please return to service information pack upon completion of work.
- ▶ These instructions do not cover all variations in systems or provide for every possible contingency to be met in connection with the installation.
- ▶ Should further information be desired or should particular problems arise which are not covered sufficiently for the purchaser's purposes, the matter should be referred to your installing dealer or local distributor.



#### **WARNING:**

- ▶ This information is intended for use by individuals possessing adequate backgrounds of electrical and mechanical experience. Any attempt to repair a central air conditioning product may result in personal injury and/or property damage.



#### **WARNING: ELECTRICAL SHOCK**

- ▶ Failure to follow this warning could result in property damage, severe personal injury, or death.
- ▶ Disconnect all electric power, including remote disconnects before servicing. Follow proper lockout/tagout procedures to ensure the power cannot be inadvertently energized.

**WARNING: PERSONAL INJURY/ENVIRONMENTAL HAZARD**

- ▶ Any attempt to repair a central air conditioning product may result in property damage, severe personal injury, or death. These units use R-410A refrigerant which operates at 50 to 70% higher pressures than R-22. Use only R-410A approved service equipment. Refrigerant cylinders are painted a “Rose” color to indicate the type of refrigerant and may contain a “dip” tube to allow for charging of liquid refrigerant into the system. All R-410A systems with variable speed compressors use a POE oil (VG74 or equivalent ) that readily absorbs moisture from the atmosphere. To limit this “hygroscopic” action, the system should remain sealed whenever possible. If a system has been open to the atmosphere for more than 4 hours, the compressor oil must be replaced. Never break a vacuum with air and always change the driers when opening the system for component replacement.

**CAUTION: HOT SURFACE**

- ▶ Do not touch top of compressor. May cause minor to severe burning. Failure to follow this Caution could result in property damage or personal injury.

**CAUTION: HIGH PRESSURE**

- ▶ Failure to follow proper procedures can result in personal illness or injury or severe equipment damage. System contains oil and refrigerant under high pressure. Recover refrigerant to relieve pressure before opening system.

**WARNING: GROUNDING REQUIRED**

- ▶ Failure to inspect or use proper service tools may result in equipment damage or personal injury. Reconnect all grounding devices. All parts of this product that are capable of conducting electrical current are grounded. If grounding wires, screws, straps, clips, nuts, or washers used to complete a path to ground are removed for service, they must be returned to their original position and properly fastened.

**CAUTION: BURN HAZARD**

- ▶ Failure to follow this warning will result in abrupt release of system charge and may result in personal injury and/or property damage. Extreme caution should be exercised when applying gauges to service ports.

**WARNING: ELECTRICAL SHOCK**

- ▶ Failure to follow this warning could result in property damage, severe personal injury, or death. Grounding is essential before connecting electrical supply.

**WARNING:**

- ▶ This product can expose you to chemicals including Lead and Lead components, which are known to the State of California to cause cancer and birth defects or other reproductive harm. For more information go to [www.P65Warnings.ca.gov](http://www.P65Warnings.ca.gov).

**NOTICE:**

- ▶ A manufactured (mobile) home installation must conform with the Manufactured Home Construction and Safety Standard, Title 24 CFR, Part 3280, or when this Standard is not applicable, the Standard for Manufactured Home Installations (Manufactured Home Sites, Communities and Set-Ups), ANSI/NCS A225.1, and/or MH Series Mobile Homes, CAN/CSA Z240.

## 2 Component Location

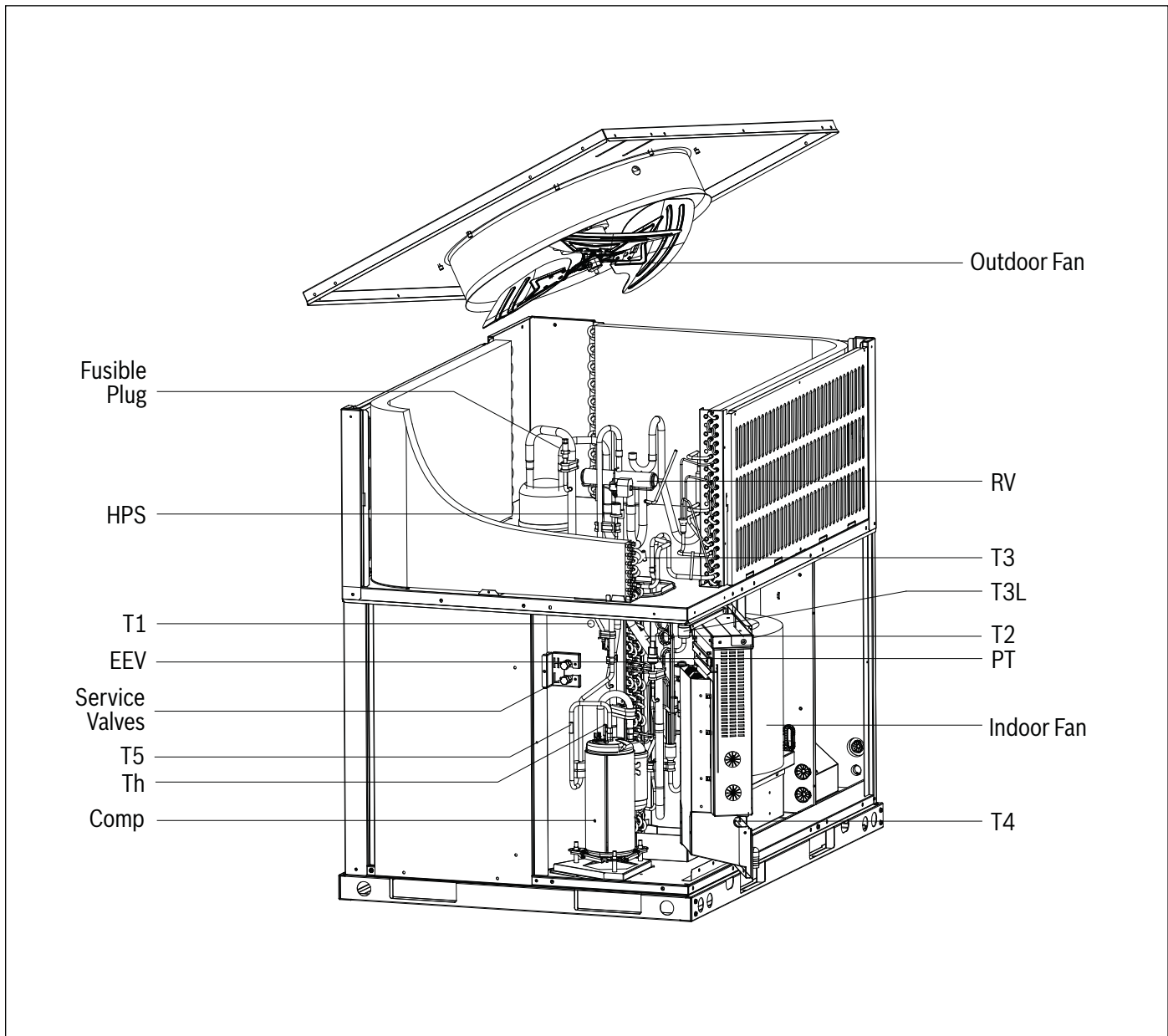

Figure 1

Component	Descriptions	Component	Descriptions
HPS	High pressure switch	T3L	Condenser outlet temp. sensor
PT	Pressure transducer	Tf	Radiator temp. sensor
T1	Return air temp. sensor	Th	Comp. return temp. sensor
T2	Indoor coil temp. sensor	EEV	Electronic expansion valve
T3	Condenser temp. sensor	RV	Reversing valve
T4	Ambient temp. sensor	COMP	Compressor
T5	Comp. discharge temp. sensor	FP	Fusible Plug

Table 1 Component Descriptions

### 3 Dimensions

#### 3.1 Unit Dimensions

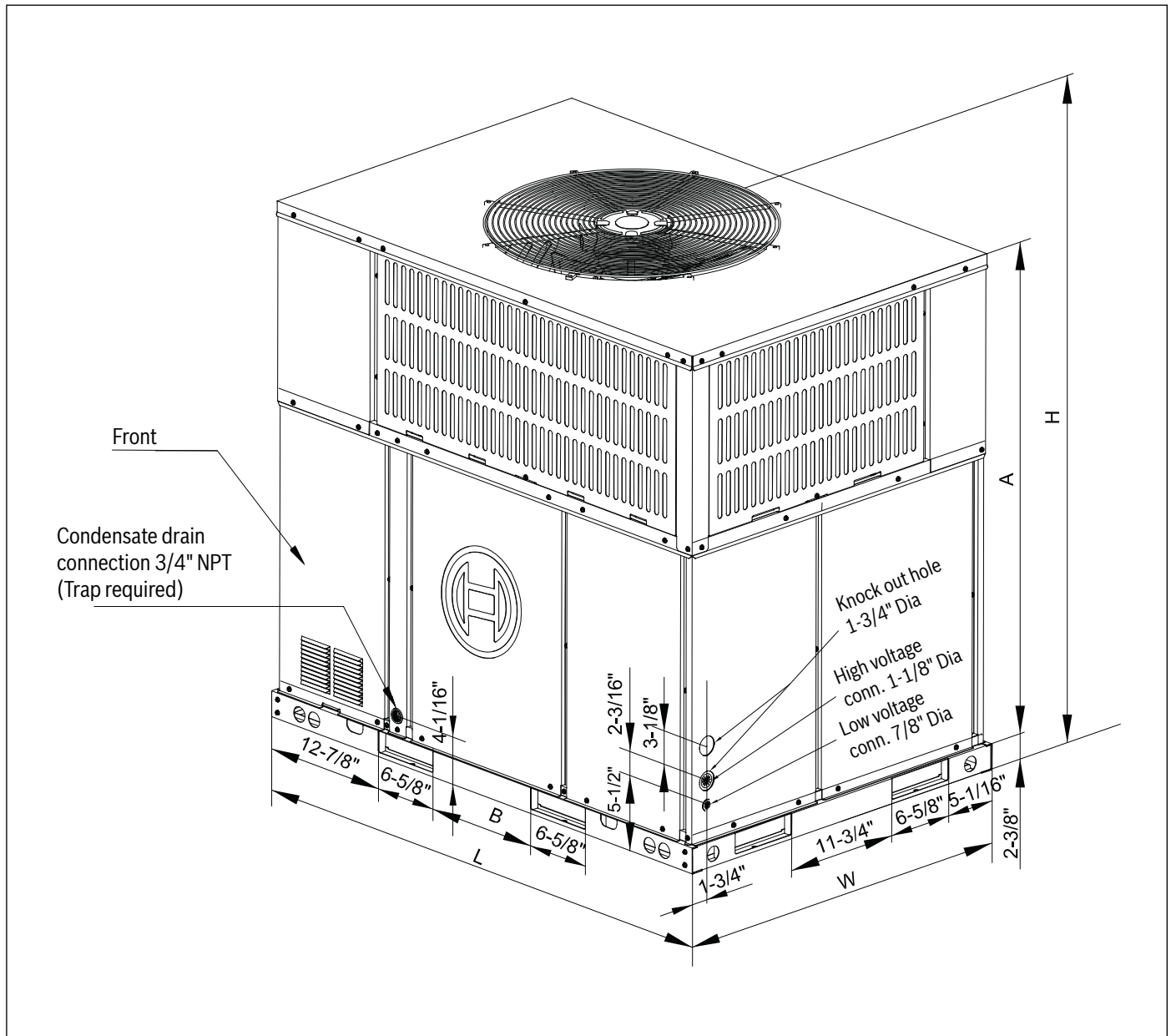

Figure 2

Heat Pump Model	L	W	H	A	B
BRB-36HWD1N1-M18	50-11/16"	35-1/16"	46-13/16"	44-1/16"	11-3/4"

Table 2 Unit Dimensions

Heat Pump Model	Net Weight	Gross Weight
BRB-36HWD1N1-M18	412 lbs (187 kg)	432 lbs (196 kg)

Table 3 Unit Weights

3.2 Dimensions - Back and Bottom

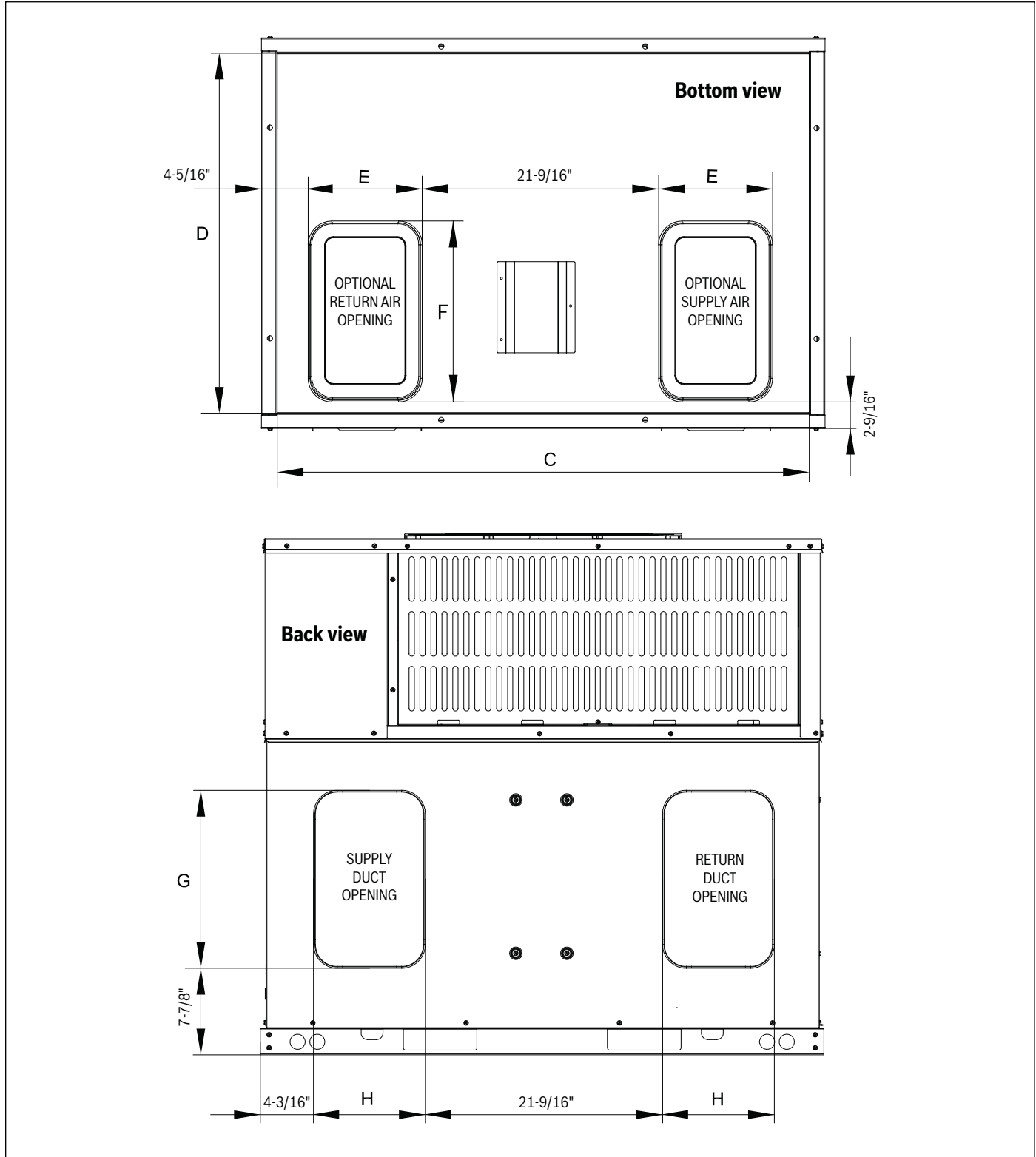

Figure 3

Heat Pump Model	C	D	E	F	G	H
BRB-36HWD1N1-M18	47-13/16"	32-1/4"	9-15/16"	15-7/8"	15-3/4"	9-3/4"

Table 4 Dimensions - Back and Bottom



3.3 Dimensions - Left and Top

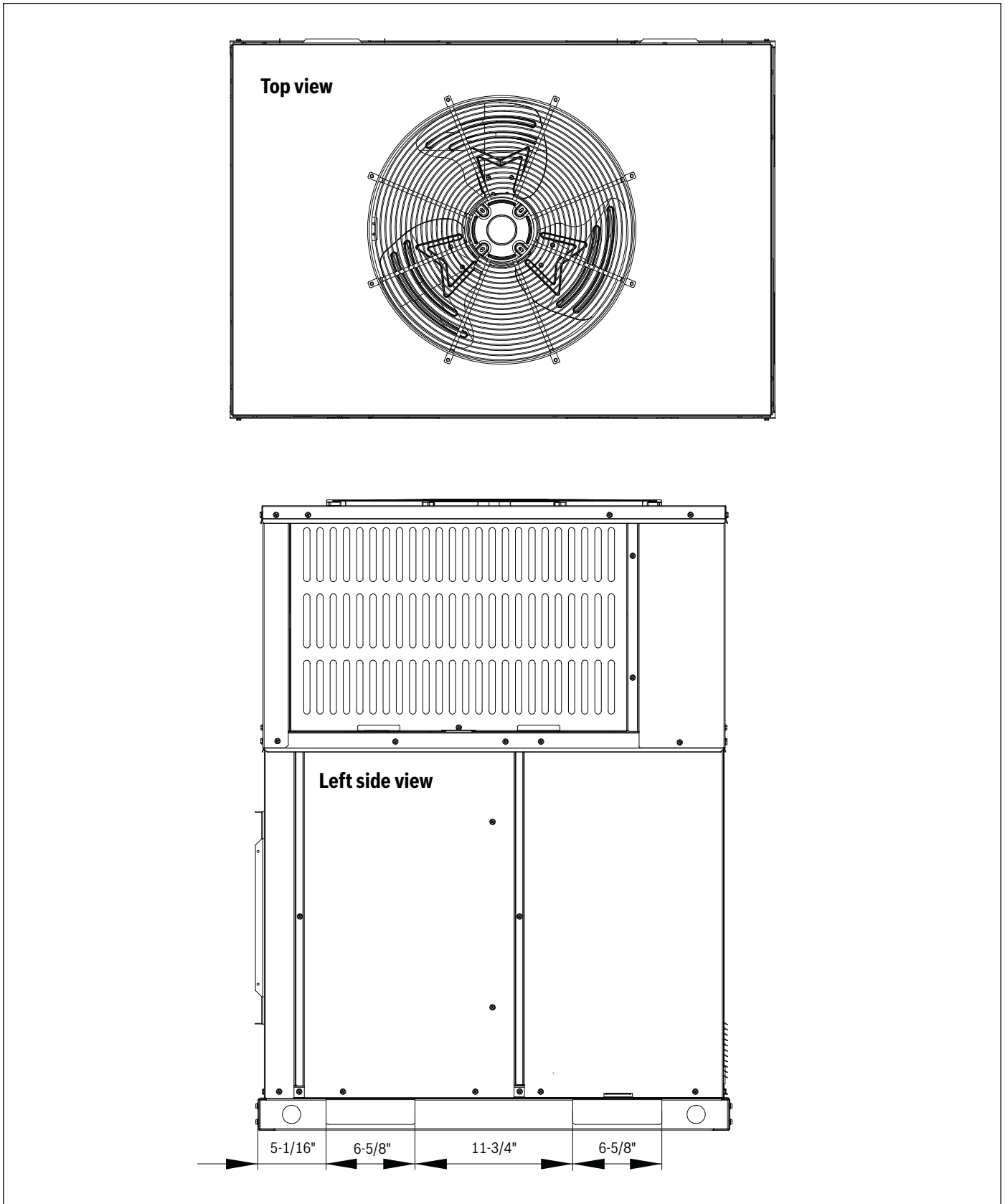

Figure 4

## 4 Installation

### 4.1 Pre-Installation

Before installation, carefully check the following:

1. Unit should be installed in accordance with national and local safety codes, including but not limited to ANSI/NFPA No. 70, local plumbing and wastewater codes and any other applicable codes.
2. For rooftop installation, be sure the structure has enough strength to support the weight of unit. Unit must be installed on a field supplied roof curb or rack and leveled.
3. For ground level installation, a field supplied level slab must be used.
4. Condenser airflow should not be restricted.
5. On applications when a roof curb is used, the unit must be positioned on the curb so the front of the unit is tight against the curb. If the unit is to be mounted on a curb in a downflow application, refer to Figure 14, and convert panels prior to rigging and lifting. The panel removal process may require the unit to be on the ground.

### 4.2 Rigging and Lifting

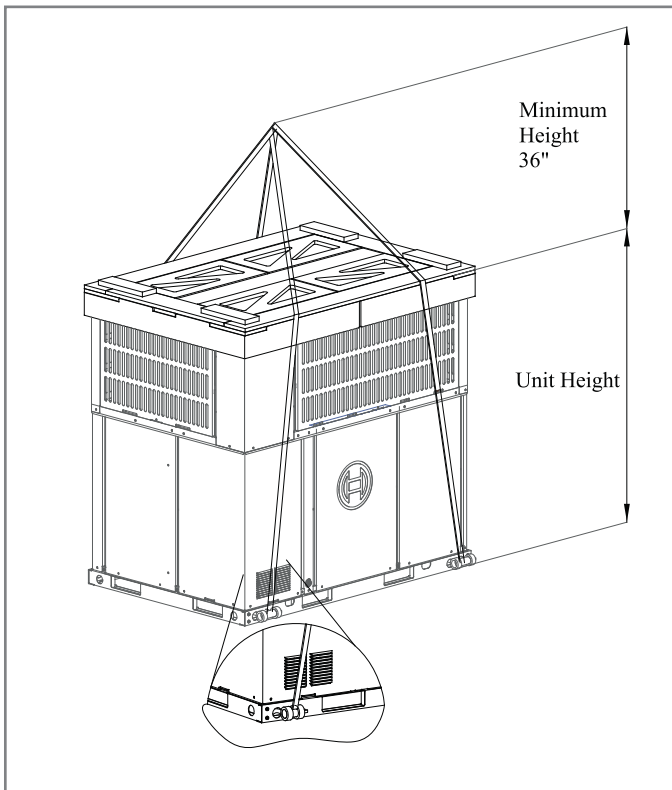

Figure 5

Exercise care when moving the unit. Do not remove any packaging until the unit is near the place of installation. Rig the unit by attaching chain or cable slings to the lifting holes provided in the base rails. Spreader bars, whose length exceeds the largest dimension across the unit, **MUST** be used across the top of the unit.

When rigging/lifting the unit, the minimum height between the top of the rigging cables' connection point and top of unit should be 36 inches. Refer to Figure 5.



#### CAUTION:

- ▶ Before lifting, make sure the unit weight is distributed equally on the rigging cables so it will lift evenly.



#### CAUTION:

- ▶ All panels must be secured in place when the unit is lifted. The condenser coils should be protected from rigging cable damage with plywood or other suitable material.

### 4.3 Location Restrictions

Ensure the top discharge area is unrestricted for at least 60 inches above the unit.

Do not locate outdoor unit near bedrooms since normal operational noise levels may be disturbing to building occupants.

Position unit to allow adequate space for unobstructed airflow, wiring, and serviceability.

Do not restrict outdoor airflow. An air restriction at either the outdoor air inlet or the fan discharge may be detrimental to compressor life.

Do not place the unit where water, ice, or snow from an overhang or roof will damage or flood the unit. Do not install the unit on carpeting or other combustible materials. Slab-mounted units should be at least 2 inches (51 mm) above the highest expected water and runoff levels. Do not use unit if it has been under water.

Maintain a distance of 24 inches between units. Position unit so water, snow, or ice from roof or overhang cannot fall directly on unit.

See Figure 7 and Figure 8 for minimum clearance requirements.

#### Cold climate considerations (heat pump only)

#### NOTICE:

- ▶ Precautions must be taken for units being installed in areas where snow accumulation and prolonged below-freezing temperatures occur.

- ▶ Units should be elevated 3-12 inches above the pad or rooftop, depending on local weather. This additional height will allow drainage of snow and will permit condensate water to drain when the unit is in defrost mode. Ensure that drain holes in unit base pan are unobstructed, preventing drainage of defrost water (See Figure 9).
- ▶ If possible, avoid locations that are prone to snow drifts. If not possible, a snow drift barrier should be installed around the unit to prevent a build-up of snow on the sides of the unit.

**i** Ensure that Condensate Drain side is pitched lower than the opposite side (see Figure 6).

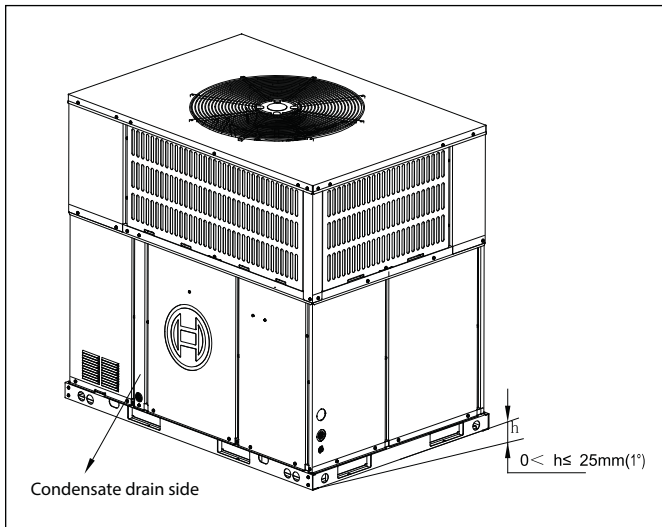

Figure 6

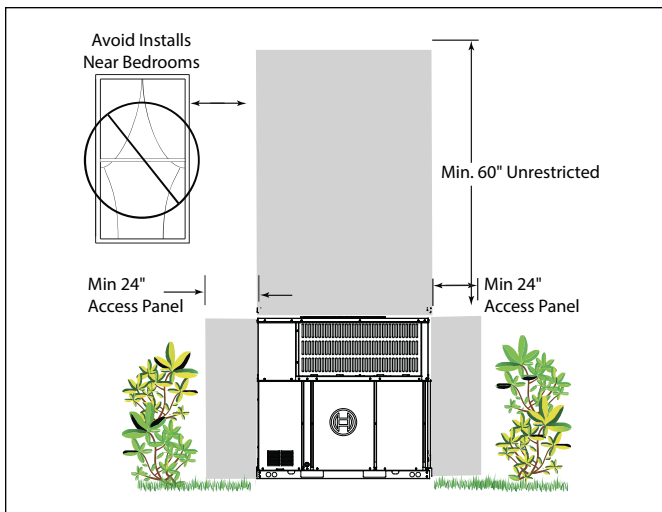

Figure 7

**i** A minimum clearance of 24" should be maintained adjacent to all access/service panels. Refer to local code requirements for additional clearance requirements.

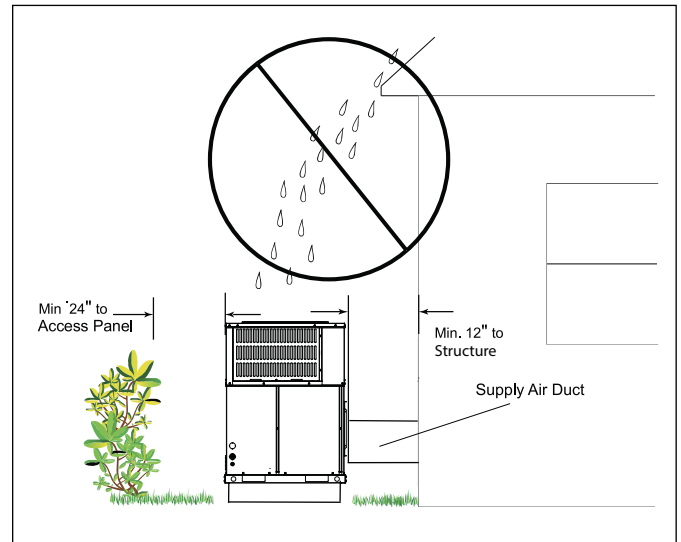

Figure 8

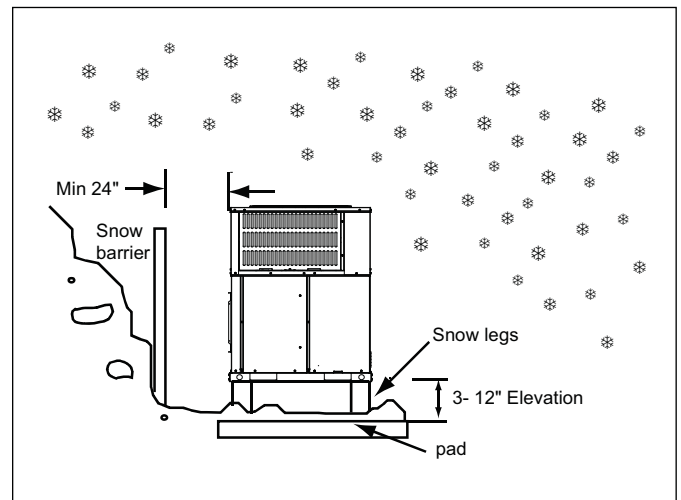

Figure 9 Insulation Layer

**Corrosive Environment**

Exposure to a corrosive environment may shorten the life of the equipment, corrode metal parts, and/or negatively affect unit performance. Corrosive elements include, but are not limited to: sodium chloride, sodium hydroxide, sodium sulfate, and other compounds commonly found in ocean water, sulfur, chlorine, fluorine, fertilizers, and various chemical contaminants from industry/manufacturing plants. If installed in areas which may be exposed to corrosive environments, special attention should be given to the equipment placement and maintenance.

- ▶ Lawn sprinklers/hoses/waste water should not spray directly on the unit cabinet for prolonged periods of time.
- ▶ In coastal areas: locate the unit on the side of the building or roof away from the waterfront.
- ▶ Fencing or shrubbery may provide some shielding protection to the unit, however minimum unit clearances must still be maintained.
- ▶ Every three months, wash the outdoor coil and any exposed cabinet surfaces.

### 4.4 Rooftop Installation - Curb Mounting

The manufacturer does not supply roof curbs, they must be field supplied. Refer to Figure 11 for recommended roof curb dimensions. On applications when a roof curb is used, the unit must be positioned on the curb so the front of the unit is tight against the curb.

The default orientation from the factory is for horizontal airflow. Convert the unit to downflow using the following procedure:

1. Remove sheet metal screws from both the supply air and return air panels. Refer to Figure 14.
2. Add foam tape on the perimeter of the non painted side of each panel.
3. Move and re-secure the panels to the downflow location using the sheet metal screws from step 1.

For more information, refer to the the Conversion Kit Manual included with each heat pump unit.

Install the field-supplied roof mounting curb according to the Installation Instructions supplied with the curb. Install insulation, cant strips, roofing, and flashing. Ductwork must be attached to curb.

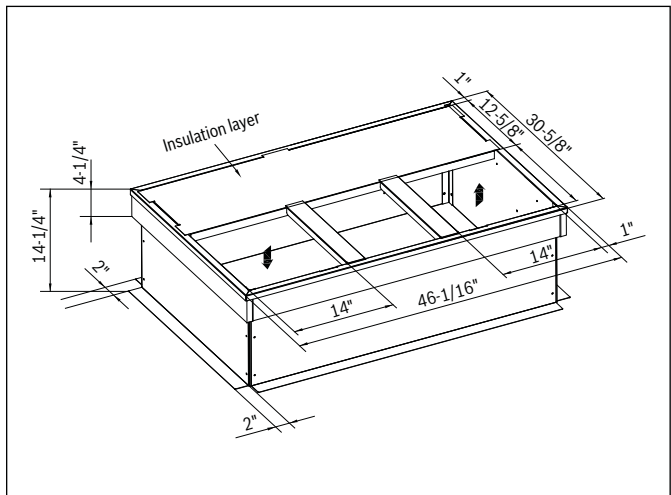

Figure 11 Roof Curb Dimensions

**i** For units applied with a roof curb, the minimum clearance may be reduced from 1 inch to 1/2 inch between combustible roof curb material and supply air duct.

**NOTICE:**

- ▶ The gasketing of the unit to the roof curb is critical for a water tight seal. Install gasketing material supplied with the field supplied roof curb. Improperly applied gasketing also can result in air leaks and poor unit performance.

**CAUTION:**

- ▶ The unit must be secured to the curb by installing screws through the bottom of the curb flange and into the unit base rails.

**NOTICE: UNIT/STRUCTURAL DAMAGE HAZARD**

- ▶ Failure to follow this caution may result in property damage. Ensure there is sufficient clearance for saw blade when cutting the outer horizontal flange of the roof curb so there is no damage to the roof or flashing.

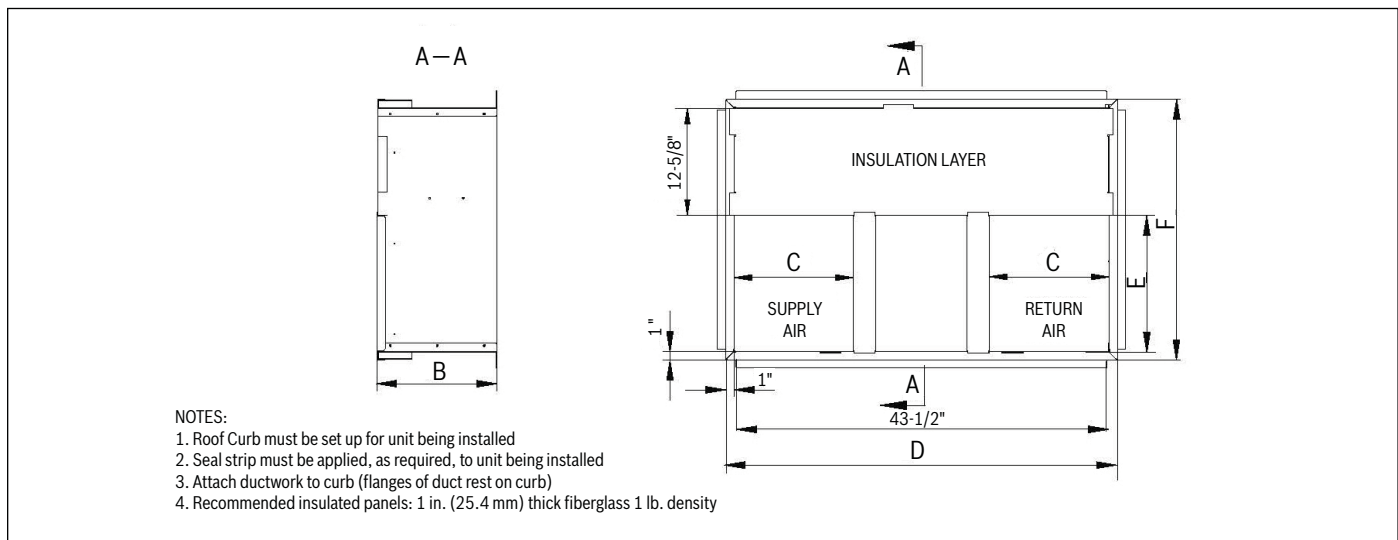

Figure 10 Roof Curb Details

	B	C	D	E	F
CURB	14-1/4"	14"	46-1/16"	16"	30-5/8"

Table 5 Roof Curb Details - inches

## 5 Airflow Performance

Airflow performance data is based on cooling performance with a coil and no filter in place. Check the performance table (Table 6) for appropriate unit size selection.

External static pressure should stay within the minimum and maximum limits shown in the table below in order to ensure proper operation of both cooling, heating, and electric heating operation.

Model Number	Motor Speed *		SCFM								
			External Static Pressure-Inches W.C. [kPa]								
			0[0]	0.1[.02]	0.2[.05]	0.3[.07]	0.4[.10]	0.5[.12]	0.6[.15]	0.7[.17]	0.8[.20]
36	Tap (1)	SCFM	925	807	723	658	/	/	/	/	/
		Watts	114	120	126	130	/	/	/	/	/
		Amps	1.07	1.12	1.17	1.19	/	/	/	/	/
	Tap (2)	SCFM	1103	993	911	841	776	710	596	/	/
		Watts	162	169	175	181	187	193	197	/	/
		Amps	1.45	1.51	1.56	1.6	1.65	1.69	1.72	/	/
	Tap (3)	SCFM	1271	1185	1098	1031	968	819	767	709	648
		Watts	251	256	262	268	273	281	285	289	293
		Amps	2.17	2.21	2.26	2.3	2.34	2.39	2.42	2.45	2.48
	Tap (4)	SCFM	1355	1310	1270	1180	1049	989	931	870	813
		Watts	296	301	307	312	318	323	327	331	336
		Amps	2.52	2.56	2.6	2.64	2.68	2.71	2.74	2.77	2.81
	Tap (5)	SCFM	1522	1465	1364	1291	1231	1177	1121	1066	1017
		Watts	426	432	438	443	448	452	456	460	466
		Amps	3.49	3.54	3.58	3.62	3.65	3.68	3.7	3.74	3.78

Table 6

 Bold outlined areas represent airflow outside of the required 300-450 cfm/ton range.

NOTES:

1. This table is only used to select the **highest blower speed**.
2. The rated airflow of systems without electric heater kits requires between 300 and 450 cubic feet of air per minute (CFM). The rated airflow of systems with electric heater kits requires between 350 and 450 cubic feet of air per minute (CFM).
3. The air distribution system has the greatest effect on airflow. Therefore, the contractor should use only industry-recognized procedures.
4. Duct design and construction should be carefully done. System performance can be lowered dramatically through poor design or workmanship.
5. Air supplier ducts should be located along the perimeter of the conditioned space and properly sized. Improper location or insufficient air flow may cause drafts or noise in the ductwork.
6. Installers should balance the air distribution system to ensure proper quiet airflow to all rooms in the home. An air velocity meter or airflow hood can be used to balance and verify branch and system airflow (CFM).
7. 4 Speed Fan default is Tap (1), Tap (2), Tap (3), Tap (4)

 For instructions on how to select fan speeds, refer to Section 6 of this manual.

## 6 Indoor Fan Motor Function

### System Operation and Function

This unit can run with either 4 Stage Fan Control or 2 Stage Fan Control. The factory default is 4 Stage Fan Control. To change the factory default parameters, refer to the information provided below.

#### Four Stage Fan Control

The IDP 3 Ton supports up to 4 fan speeds. The fan speed will automatically change according to the temperature difference between T1 (return air temperature) and Ts (estimated thermostat set point). Higher differences in temperature between T1 and Ts relate to higher fan speeds. This fan control is supported by either a single or two stage thermostat.

The ECM Constant Torque motor has 5 selectable speed taps. The unit can use up to 4 fan speeds by setting the SW6-4 dip switch to the "ON" position (default). For determining the required airflow, refer to the Airflow Performance Table (Table 6). To select the fan speeds, change SW6-1 and SW6-2 dip switches, refer to Table 7 for dip switch speed configuration.

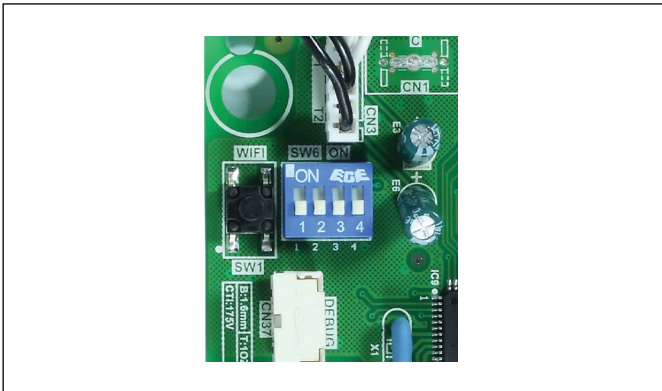

Figure 12

SW6-4	SW6-1	SW6-2	High	Mid-high	Mid	Low
ON*	OFF	OFF	2	2	1	1
	OFF	ON	3	2	2	1
	ON*	OFF*	4	3	2	1
	ON	ON	5	4	3	2

Table 7

\*Note: Default Fan Speed is SW6-4 ON, SW6-1 ON, SW6-2 OFF

#### Two Stage Fan Control

The IDP supports two stage fan control which requires a two stage thermostat (Y1&Y2). When there is a call for Y2, the blower motor will turn to high speed setting. When there is a call for Y1, the blower motor will turn to low speed setting. Unit will run at low speed setting when there is only G call. It will run in high speed setting when there is W/W1/W2 signal (when the electric heat kit is on).

Customers can select two stage fan control by setting the SW6-4 dip switch to the "OFF" position. Select the two fan speeds using the SW6-1 and SW6-2 dip switches, refer to Table 8. Refer to Airflow Performance Table (Table 6) for reference airflow.

If 2 stage thermostat is not available, single stage thermostat may be used, please refer to Wiring Diagram section for wiring instructions. If Y1 and Y2 are jumped, the unit will only run in high stage fan speed.

SW6-4	SW6-1	SW6-2	High	Mid-high	Mid	Low
OFF	OFF	OFF	2	/	1	/
	OFF	ON	3	/	1	/
	ON	OFF	4	/	2	/
	ON	ON	5	/	3	/

Table 8

#### Anti-Cold Air Fan Delay

The Anti-Cold Air Fan Delay function utilizes a sensor (T2) located on the indoor coil, which prevents the blower from turning on until the coil has reached a certain temperature. This feature prevents cold air blow during heating operation and is activated by setting SW6-3 dip switch to the "ON" position (default), refer to Figure 12 and Table 9.

- When SW6-3 dip switch is set to the "ON" position and the unit is in heating mode, the Anti-Cold Air Fan Delay function will activate based on the following entry conditions (all 3 conditions must be met):
  - Indoor Coil Temperature (T2) < 82.4 °F
  - Electric heat kit is turned off
  - There is a call for Y1 from thermostat to indoor unit
- This function will deactivate if ONE OF the following exit conditions are met OR the system has been operating in heating mode for 15 minutes.
  - T2 ≥ 89.6 °F
  - Heater kit is turned on
  - The system is NOT running Heat mode
- During the heating mode, if one of the exit conditions of Anti-Cold Air is satisfied, the blower motor will turn on in first stage fan speed.
- During the heating mode, if all of the entry conditions of Anti-Cold Air are met and maintained for 120s, the blower motor will change to first stage speed.

SW6-3	
ON*	Heat: Anti-Cold Air Fan Delay via Temp Sensor
OFF	Heat: Timed Fan Delay

Table 9

\*Note: Default is ON

#### Heating Fan Delay

If SW6-3 dip switch is set to the "OFF" position (refer to Table 9), and the unit is in heating mode, the blower will operate with a 90 second delay with the fan speed dictated by Y1 or Y2 signal.

#### Passive Dehumidification (Optional)

IDP 3 Ton has a Passive Dehumidification function which lowers the fan speed and optimizes the compressor operation with a DH call from the thermostat. This function requires proper DH wiring from the indoor unit to the thermostat (with a humidistat).



If DH wire is not connected, the unit will still function normally, but will not be able to run in dehumidification mode.



## 7 Ductwork

Field ductwork must comply with the National Fire Protection Association NFPA 90A, NFPA 90B and any applicable local ordinance(s).



### WARNING: FIRE HAZARD AND CARBON MONOXIDE

- ▶ Do not, under any circumstances, connect return ductwork to any other heat producing device such as fireplace insert, stove, etc. Unauthorized use of such devices may result in fire, carbon monoxide poisoning, explosion, personal injury or property.

Sheet metal ductwork run in unconditioned spaces must be insulated and covered with a vapor barrier. Fibrous ductwork may be used if constructed and installed in accordance with SMACNA Construction Standard on Fibrous Glass Ducts. Ductwork must comply with National Fire Protection Association as tested by U/L Standard 181 for Class I Air Ducts. Check local codes for requirements on ductwork and insulation.

- ▶ Duct system must be designed within the range of external static pressure the unit is designed to operate against. It is important that the system airflow be adequate. Make sure supply and return ductwork, grills, special filters, accessories, etc. are accounted for in total resistance. See airflow performance tables in Section 5 of this manual.
- ▶ Design the duct system in accordance with "ACCA" Manual "D" Design for Residential Winter and Summer Air Conditioning and Equipment Selection. Latest editions are available from: "ACCA" Air Conditioning Contractors of America, 1513 16th Street, N.W., Washington, D.C. 20036. If duct system incorporates flexible air duct, be sure pressure drop information (straight length plus all turns) shown in "ACCA" Manual "D" is accounted for in system.



If an elbow is included in the plenum close to the unit, it must not be smaller than the dimensions of the supply duct flange on the unit.

### NOTICE:

- ▶ The front flange on the return duct (if connected to the blower casing) must not be screwed into the area where the power wiring is located. Drills or sharp screw points can damage insulation on wires located inside unit.
- ▶ Secure all ducts to roof curb and building structure on downflow discharge units. Do not connect ductwork to unit. For horizontal applications, unit is provided with flanges on the horizontal openings. All ductwork should be secured to the flanges using proper fasteners for the type of duct used and tape the duct-to-unit joint as required to prevent air leaks.

### NOTICE:

- ▶ When fastening ductwork to the side duct flanges on the unit, insert the screws through the duct flanges only. DO NOT insert the screws through the casing. Outdoor ductwork must be insulated and waterproofed.



Be sure to note supply and return openings. Refer to Figure 3 for information concerning supply and return air duct dimensions.

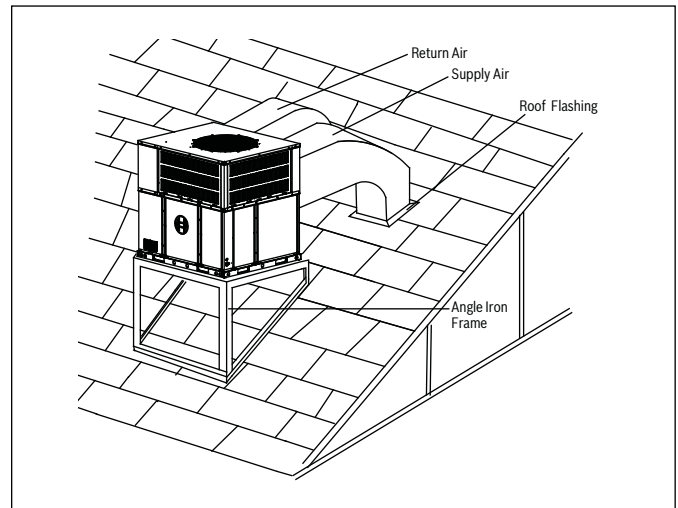

Figure 13 Rooftop Installation - Frame Mounting

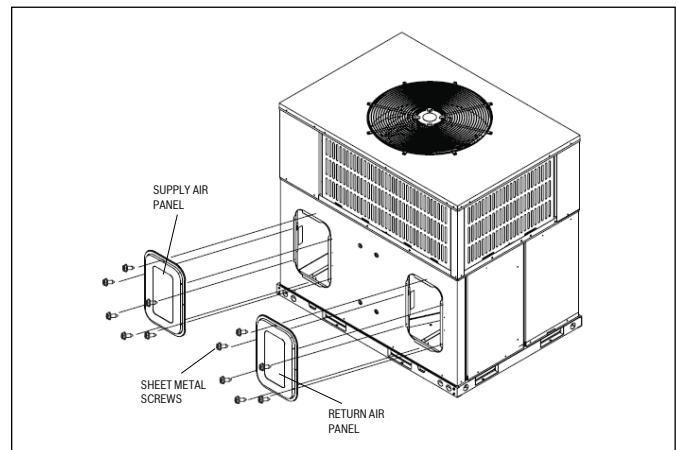

Figure 14

Note: Refer to downflow conversion instructions provided with the unit

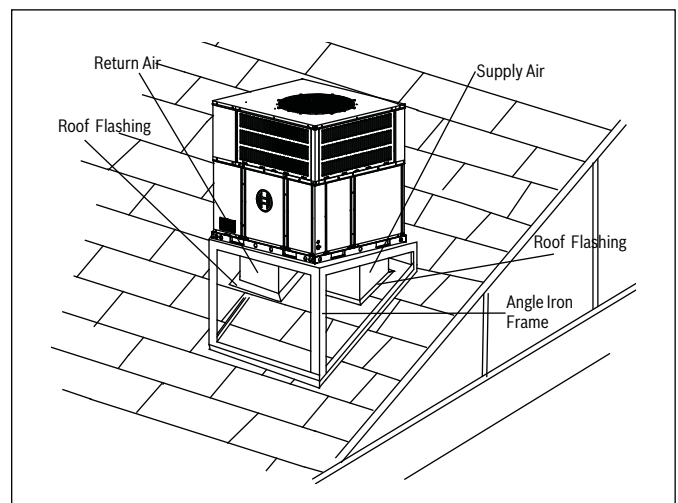

Figure 15 Typical Rooftop Downflow Application with Frame

## 8 Condensate Drain Connection

Unit should be installed in accordance with national and local safety codes, including but not limited to ANSI/NFPA No. 70, local plumbing and wastewater codes and any other applicable codes.

### 8.1 Install Drain Pipe

1. Ensure drain lines do not block access to front of the unit. Minimum clearance of 24 inches is required for filter, coil or blower removal and service access.
2. Make sure unit is leveled or pitched slightly towards primary drain connection so that water will drain completely from the pan.
3. Do not reduce drain line size to less than connection size provided on condensate drain pan.
4. All drain lines must be pitched downward away from the unit at a minimum of 1/8" per foot of line to ensure proper drainage.
5. Do not connect condensate drain line to a closed or open sewer pipe. Run condensate to an open drain or run line to a safe outdoor area.
6. The drain line should be insulated where necessary to prevent sweating and damage due to condensate forming on the outside surface of the line.
7. Make provisions for disconnecting and cleaning of the primary drain line should it become necessary. Install a 2 inch trap in the primary drain line as close to the unit as possible. Make sure that the top of the trap is below connection to the drain pan to allow complete drainage of pan.

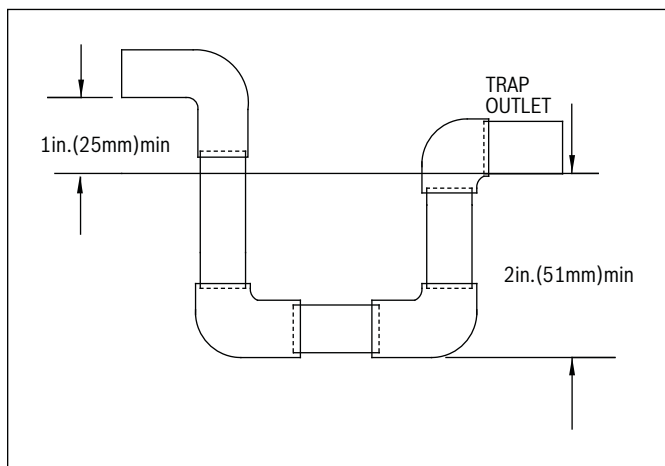

Figure 16

**i** When making drain fitting connections to the drain pan, use a thin layer of Teflon paste, silicone or Teflon tape and install by hand tightening.

**i** When making drain fitting connections to drain pan, do not overtighten. Overtightening fittings can split pipe connections on the drain pan.

## 9 Air Filter (Not Factory-Installed)

Filters and filter racks are not included with the unit and must be field supplied.

An external filter or other means of filtration must be properly sized for a maximum of 300 feet/min. air velocity or what is recommended for the type of filter installed.

Filter application and placement are critical to airflow, which may affect the heating and cooling system performance. Reduced airflow can shorten the life of the system's major components, such as motor, elements, heat relays, evaporator coil or compressor. Consequently, we recommend that the return air duct system have only one filter location. For systems without a return air filter grill, multiple filter grills can be installed at each of the return air openings.

If adding high efficiency filters or electronic air filtration systems, it is very important that the air flow is not reduced. If air flow is reduced the overall performance and efficiency of the unit will be reduced. It is strongly recommended that a professional installation technician is contacted to ensure such filtration systems are installed correctly.

**i** Do not double filter the return air duct system. Do not filter the supply air duct system. This will change the performance of the unit and reduce airflow.



### WARNING: FIRE HAZARD

- ▶ Do not operate the system without filters. A portion of the dust suspended in the air may temporarily lodge in the duct runs and at the supply registers. Any circulated dust particles could be heated and charred by contact with the air handler elements. This residue could soil ceilings, walls, drapes, carpets and other articles in the house. Soot damage may occur with filters in place, when certain types of candles, oil lamps or standing pilots are burned.

Heat Pump Model	No.	Size Recommended
BRB-36HWD1N1-M18	1	16"x10"x1"

Table 10



## 10 Electrical Wiring

Field wiring must comply with the National Electric Code (NEC) and any applicable local ordinance.



### WARNING: ELECTRICAL SHOCK

- ▶ Disconnect all power to unit before installing or servicing. More than one disconnect switch may be required to de-energize the equipment. Hazardous voltage can cause severe personal injury or death.

### 10.1 Power Wiring

1. It is important that proper electrical power is available for connection to the unit being installed. See the unit nameplate, wiring diagram, and electrical data in the installation instructions for more detailed requirements. Voltage tolerance should not be over 10% from rating voltage.
2. If any of the wiring must be replaced, replacement wiring must be the same type as shown in nameplate, wiring diagram and electrical data sheet.
3. Install a branch circuit disconnect of adequate size to handle starting current, located within sight, and readily accessible to the unit.
4. **Electric Heater:** If the optional Electric Heat Kit is installed, the unit should be equipped with suitable circuit breakers or fuse. Refer to Table 11 and 12 for more information. These breaker(s) protect the internal wiring in the event of a short circuit and serve as a disconnect. Circuit breakers installed within the unit do not provide over-current protection of the supply wiring and therefore may be sized larger than the branch circuit protection.
  - ▶ Supply circuit power wiring must be 221 °F minimum copper conductors only. Refer to Table 11 and 12 for ampacity, wire size and circuit protector requirements. Supply circuit protective devices may be either fuses or "HACR" type circuit breakers. 1-3/8" knockouts inside the cabinet are provided for connection of power wiring to electric heater.
  - ▶ Power wiring is connected to the power terminal block in unit electric cabinet. See Electric Heater Kit Installation Instructions for details.
5. See wiring diagram located on inside of control board access panel for proper wiring instructions.

### 10.2 Grounding



### WARNING: ELECTRICAL SHOCK

- ▶ The unit must be permanently grounded. Failure to do so can result in electrical shock causing personal injury or death.
- ▶ The unit must be electrically grounded in accordance with local codes and the National Electric Code (NEC).
  - ▶ Grounding may be accomplished by attaching ground wire(s) to ground lug(s) provided in the unit wiring compartment.

### 10.3 Control Wiring



### WARNING: FIRE HAZARD

- ▶ Low voltage control wiring should not be run in conduit with high voltage wiring. Keep distance between the two conduits per local codes.
- ▶ 18 AWG. color-coded low voltage wire should be used for lengths less than 100 ft. For wire lengths longer than 100 ft., 16 AWG. wire should be used.
  - ▶ 7/8" knockout hole should be used to route control wires into the unit.
  - ▶ After installation, ensure separation of low voltage and high voltage wiring is maintained.

Refer to Figure 18 for thermostat wiring diagrams.

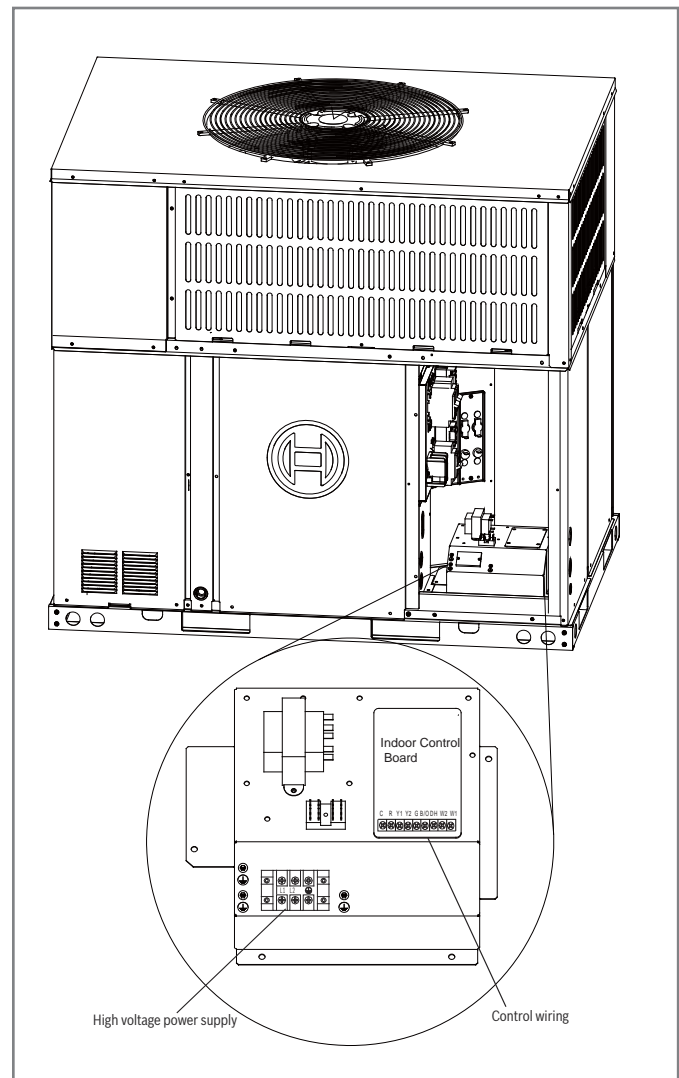

Figure 17

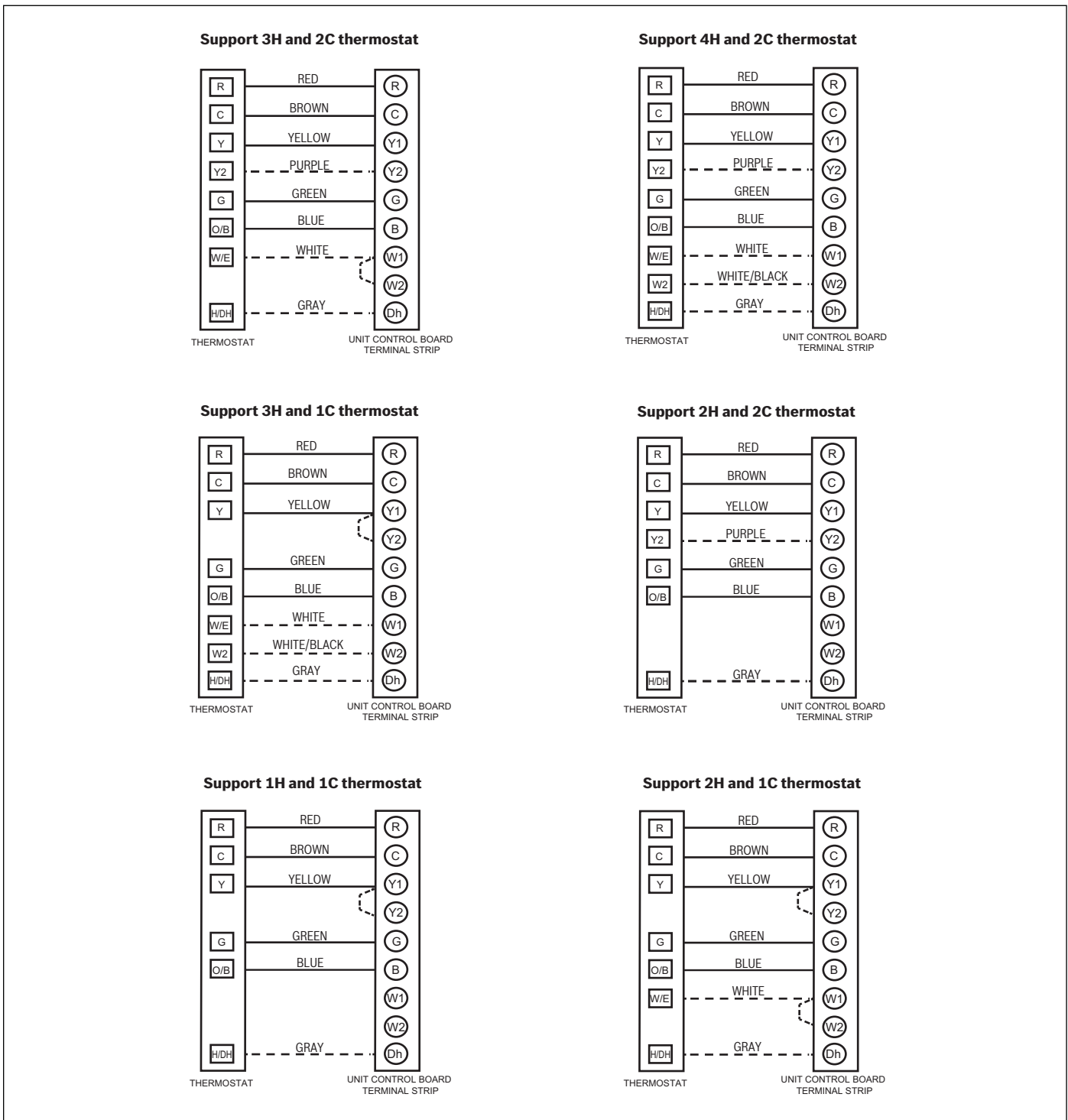

Figure 18 Thermostat Wiring Diagrams

**i** Dh wiring is optional and requires a thermostat with a humidistat. Dh functions as Passive Dehumidification and will downstage the indoor fan speed. System will operate according to normal sequence of operations if Dh wiring is absent.

**i** Y2 wiring is optional for 4 speed fan control. For 2 stage fan control Y2 wiring is required.

**i** Dashed lines in the above thermostat wiring diagrams refer to optional wiring (wiring for Passive Dehumidification Function and/OR Electric Heat, and 2 stage fan control). For thermostat wiring please refer to the Owner’s Manual of the thermostat.

**i** B wire must be used with heat pump system only, the reversing valve energizes in heating.



**WARNING: ELECTRICAL SHOCK**

- ▶ Label all wiring prior to disconnection when servicing controls. Wiring errors can cause improper and dangerous operation. Verify proper operation after servicing.

Size (Tons)	Voltage - Phase - Frequency	Compressors (each)		OD Fan Motors (each)	Supply Blower Motor	Unit Circuit	
		RLA	LRA	FLA	FLA	MCA <sup>1</sup> (Amps)	Max Fuse <sup>2</sup> / Breaker <sup>3</sup> Size (Amps)
36 (3)	208/230-1-60	19A	52A	1.4A	3.5A	28.7	45

Table 11 Electrical Data Without Electric Heat

Model	kW 208/240	Stages	Heater Circuit				
			FLA (Amps)	Dual Point		Single Point	
				MCA <sup>1</sup> (Amps)	Max Fuse <sup>2</sup> / Breaker <sup>3</sup> Size (Amps)*	MCA (AMPS)	Max Fuse <sup>2</sup> / Breaker <sup>3</sup> Size (Amps)**
EHK-05J	3.8/5	1	18.1/20.8	23/26	25/30	52/55	60/60
EHK-08J	5.6/7.5	1	27.1/31.3	34/40	35/40	63/68	70/70
EHK-10J	7.5/10.0	1	36.1/41.7	46/53	50/60	74/81	80/90
EHK-15J	11.3/15	2	54.2/62.5	68/79	70/80	97/107	100/110

Table 12 Electrical Data With Electric Heat

1. Minimum Circuit Ampacity.
2. Maximum Over Current Protection per Standard UL 1995.
3. Fuse or HACR breaker size field installed.

\* Max Fuse/Breaker Sizes are for electric heater ONLY (dual point electric heat). DOES NOT include breaker size for the unit.

\*\*Max Fuse/Breaker Sizes include breaker size for the unit AND electric heat (single point electric heat).



Refer to Electric Heat Kit Installation Manual, some heater kits include fuses from the manufacturer.



**WARNING: ELECTRICAL SHOCK / FIRE HAZARD**

- ▶ Any power supply and circuits must be wired and protected in accordance with federal, state and local electrical codes.

**11 Start Up**

**11.1 System Start Up**

1. Ensure Sections 4, 5, 6, 7, and 8 have been completed.
2. Set System Thermostat to OFF.

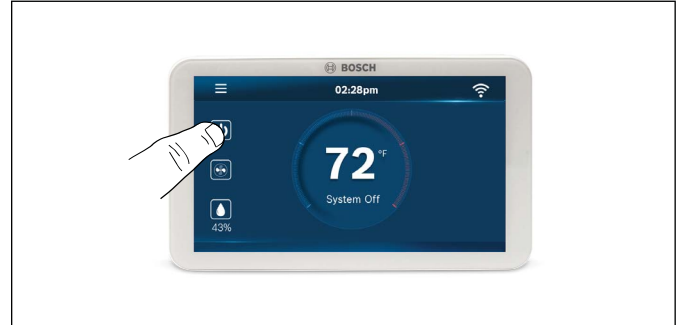

Figure 19

3. Turn on disconnect to apply power to the indoor and outdoor units.

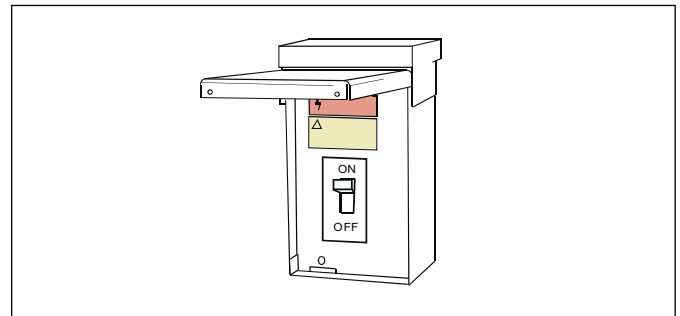

Figure 20

4. Wait one (1) hour before starting the unit if compressor crankcase heater is used and the outdoor ambient temperature is below 70 °F.



Figure 21

5. Set system thermostat to ON.



Figure 22

## 12 System Charge Adjustment



The unit comes precharged from the factory with 7-8 lb-oz of refrigerant. Follow Section 12 for charge adjustments i.e if components have been replaced, or if there is a suspected leak.

### 12.1 Charging: Weigh-In Method

Weigh-in method is recommended anytime a system charge is being replaced. Weigh-in method can also be used when power is not available to the equipment site or operating conditions (indoor/outdoor temperatures) are not in range to verify with the subcooling charging method.

Heat Pump Model	Refrigerant Charge (lb-oz)
BRB-36HWD1N1-M18	7-8

Table 13

### 12.2 Subcooling Charging and Refrigerant Adjustment In Cooling (Above 55°F Outdoor Temp.)

1. Check the outdoor ambient temperatures.

Subcooling (**in cooling mode**) is the only recommended method of charging above 55°F outdoor ambient temperatures. For outdoor ambient temperatures below 55°F, use weigh-in charge method.



It is important to return in the spring or summer to accurately charge the system in the cooling mode when outdoor ambient temperature is above 55°F.

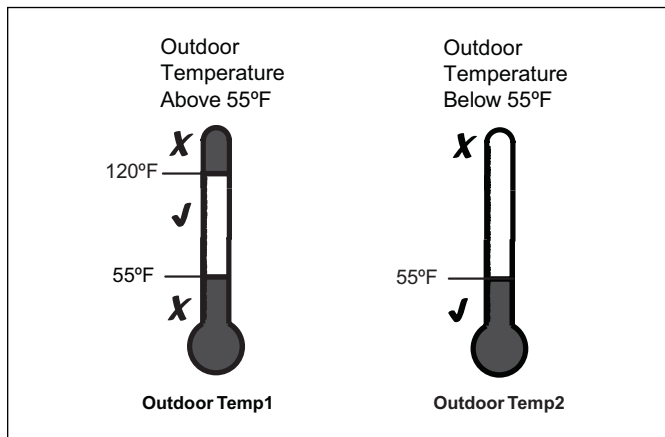

Figure 23

For best results the indoor temperature should be kept between 70°F to 80°F.

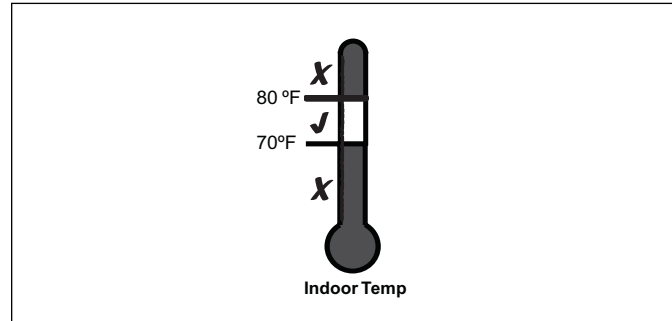

Figure 24

2. Stabilize the system.
3. After **starting the system in cooling mode**, short press “FORCE” button, and a “—” symbol should appear. System may take 10 minutes to ramp up. Operate the system for a minimum of twenty (20) minutes.

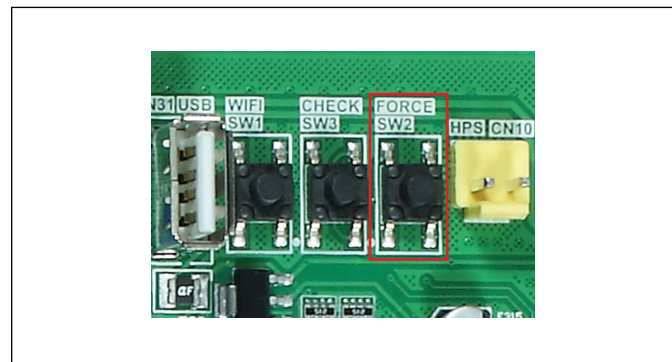

Figure 25



SW1 is not used.



After a twenty (20) minute stabilization period operating at 100% capacity (72 Hertz), maintain continuous operation while adjusting refrigerant charge. After adjusting, operate system for a minimum of five (5) minutes for system to stabilize, otherwise repeat step 3.



Figure 26

4. Calculate subcooling value on liquid line (According to Table 14)
  - ▶ Measured Liquid Line Temp. = \_\_\_\_\_°F
  - ▶ Measured Liquid Line Pressure = \_\_\_\_\_ PSIG
  - ▶ Calculate subcooling value = \_\_\_\_\_°F

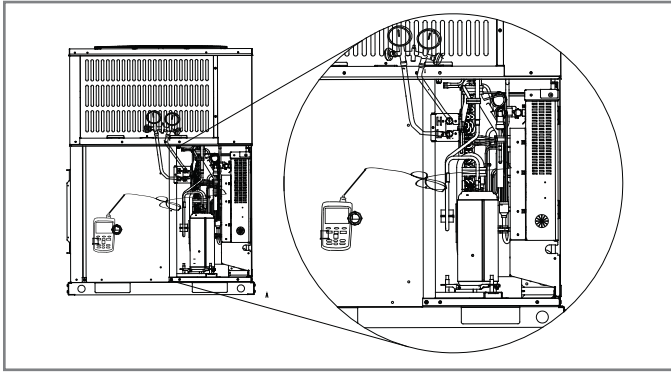

Figure 27

**i** Ensure the temperature sampling position as shown above.

**i** If calculated subcooling value is lower than the design subcooling value (Table 15), please add refrigerant. Repeat steps 2 through 4.

Liquid Line Temp (°F)	Final Subcooling(°F)							
	6	7	8	9	10	11	12	13
55	173	176	179	182	185	188	191	195
60	188	191	195	198	201	204	208	211
65	204	208	211	215	218	221	225	229
70	221	225	229	232	236	239	243	247
75	239	243	247	251	255	259	262	266
80	259	262	266	270	275	279	283	287
85	279	283	287	291	295	300	304	309
90	300	304	309	313	318	322	327	331
95	322	327	331	336	341	346	351	355
100	346	351	355	360	365	370	376	381
105	370	376	381	386	391	397	402	407
110	397	402	407	413	418	424	430	435
115	424	430	435	441	447	453	459	465
120	453	459	465	471	477	483	489	496
125	483	489	469	502	508	515	521	528

Table 14 R-410A Refrigerant Chart - Final Subcooling

Heat Pump Model	Design Subcooling
BRB-36HWD1N1-M18	12°F ± 4°F

Table 15

5. Adjust refrigerant level to attain proper gauge pressure.

**i** **Add refrigerant** if the subcooling reading from Table 14 is lower than the designed value (Table 15).

- ▶ Connect gauges to refrigerant bottle and unit as illustrated (Figure 27 and 28).
- ▶ Purge all hoses.
- ▶ Open tank.
- ▶ Stop adding refrigerant when subcooling matches the charging chart (Table 14) Final Subcooling value.

**i** **Recover refrigerant** if the subcooling reading from Table 14 is higher than the designed value (Table 15).

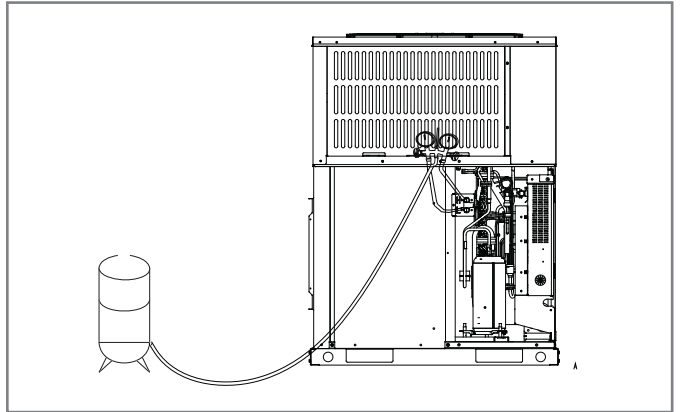

Figure 28

- 6. Stabilize the system.
  - ▶ Wait 5 minutes for the system condition to stabilize between adjustments.

**i** When the subcooling matches the chart, the system is properly charged.

- ▶ Remove gauges.
  - ▶ Replace service port caps to prevent leaks. Tighten finger tight plus an additional 1/6 turn.
7. Record System Information for reference (Table 16). Record system pressures and temperatures after charging is complete.

**i** The subcooling also can be calculated by pressing check button after getting T3 and T3L temperatures (refer to table 21).

Description	Value
Outdoor model number	
Measured Outdoor Ambient	°F
Measured Indoor Ambient	°F
Check Condenser Outlet Temp.(T3L)	°F
Check Condenser Temp.(T3)	°F
Calculate subcooling value =T3-T3L	°F

Table 16

## 13 System Operation and Troubleshooting

### 13.1 Control Logic Description

- ▶ The variable speed system adopts the same 24VAC control as any conventional heat pump.
- ▶ The compressor's speed is controlled based on coil pressures monitored by the unit's pressure transducer. To ensure stable and adequate capacity, the compressor speed will modulate relative to evaporator pressure during cooling operation and relative to condensing pressure during heating operation. The target pressure can automatically adjust based on compressor operation so optimal capacity can be achieved. Target pressure can be manually adjusted (SW4) to achieve improved dehumidification and capacity demands.

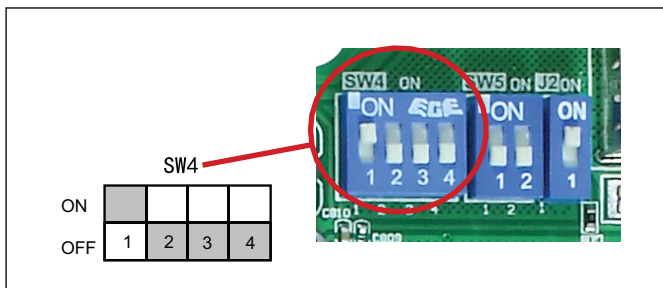

Figure 29

SW4-1	ON*	Must be set at "ON" position
	OFF	Unused
SW4-2	ON	Unused
	OFF*	Must be set to "OFF" position
SW4-3	ON	Adaptive capacity output disabled
	OFF*	Adaptive capacity output enabled
SW4-4	ON	Accelerated cooling/heating
	OFF*	Normally cooling/heating

Table 17

\*Factory Default

- ▶ Adaptive capacity function is a "self-learning function" which allows a range of target coil temperatures to adapt for better unit operation and reduced short cycling.
- ▶ Accelerated cooling/heating function changes the initial target coil temperature to provide "enhanced comfort" by increasing unit capacity.

### 13.2 Sensors (Thermistors/Pressure Transducer)

- ▶ T1 = Return Air Temperature
  - Indoor Fan Control
- ▶ T2 = Indoor Coil Temperature
  - Anti-cold air function in heating mode
- ▶ T3 = Outdoor Coil Temperature
- ▶ High/Low temperature protection
  - Outdoor fan control (cooling mode)
  - Defrost control (heating mode)
- ▶ T4 = Ambient Temperature
  - Operating condition permission
  - Defrosting condition permission
  - Outdoor fan control (heating mode)
- ▶ T5 = Compressor Discharge Temperature
  - High/Low temperature protection
  - Electronic Expansion Valve (EEV) (ODU/heating mode only)
- ▶ Th = Compressor Return Temperature
- ▶ T3L = Liquid Line Temperature
- ▶ TF = Control Board Module Temperature
  - Inverter High Temperature Protection
- ▶ Pressure transducer
  - Compressor frequency control
  - Electronic Expansion Valve (EEV) control (in both heating and cooling modes)
  - High pressure protection (heating mode)
  - Low pressure protection (cooling mode)

### 13.3 Defrost Description

- ▶ The Demand Defrost Control (DDC) monitors the ODU coil temperature using thermistor (T3). A second thermistor (T4) monitors outdoor ambient temperature. Based on these parameters, as well as accumulative run time and high pressure, the DDC calculates proper initiation of defrost.
- ▶ Any one of the below three conditions is required to enter defrost:
  1. The calculated temperature difference between the outdoor temperature (T4) and the coil temperature (T3) is called Delta T. After Delta T is achieved and continues for 3 minutes.
    - T4 ≥ 39°F, Delta T = 18°F
    - T4 ≥ 30°F, Delta T = 16°F
    - T4 ≥ 19°F, Delta T = 14°F
    - When T4 < 19°F, T3 < 9°F, accumulative compressor run time ≥ 80 minutes.
  2. After “Minimum Run Time” (MRT) is achieved. MRT is based on outdoor ambient temperature (T4), for example:
    - MRT is 4 hours when: T4 < 23°F
    - MRT is 2 hours when: 23°F ≤ T4 < 42°F
  3. After the high pressure saturation temperature drops below 82°F for 20 minutes.
- ▶ Defrost will terminate once outdoor coil temperature (T3) reaches 64°F for a period of 1 minute or defrost time has exceeded 8 minutes.
- ▶ Defrost Termination Settings (SW5) offers different defrost termination options for enhanced defrost for different geographical and outdoor conditions.

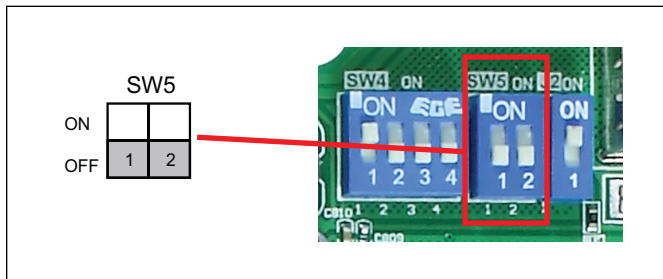

Figure 30

Defrosting Choice	SW5-1	SW5-2	Remarks
ON	Operating time is reduced by 10%	Defrosting extended for 60 seconds	
OFF	Normal	Normal	Default
Remarks	Enter defrost	Quit defrost	

Table 18

#### ▶ Manual Defrost:

1. System must have a call for heat and have been operating for a minimum of 8 minutes.
2. Press “Force” button on inverter board for 6 seconds to begin forced defrost.
3. Wait approximately 40 seconds for defrost to initiate.
4. Once defrost initiates, the display will indicate “dF”.
5. Defrost test will terminate automatically, after which the display will indicate running speed.
6. If a second defrost test is required, repeat steps 2-5 after 5 minutes.

### 13.4 Compressor Crankcase Heater Description

Refrigerant migration during the OFF cycle can result in noisy start-ups, therefore a CrankCase Heater (CCH) is used to minimize refrigerant migration thereby minimizing start-up noise and/or bearing “wash out”. All CCHs must be installed on the lower half of the compressor shell. Its purpose is to warm the compressor during the OFF cycle, driving refrigerant from compressor. After extended shutdown periods in cold weather, it is recommended to allow CCH to be energized for at least 12 hours prior to compressor operation by applying line voltage to heat pump with thermostat OFF.

#### ▶ CCH operation energizes:

1. First time line voltage is applied and compressor discharge temperature T5 < 53.6°F.
2. Compressor stops running for 3 hours (outdoor ambient temperature T4 < 41°F OR compressor discharge temperature T5 < 53.6°F).

#### ▶ CCH operation de-energizes:

1. Compressor discharge temperature T5 ≥ 60.8°F.
2. Compressor start running.

### 13.5 Reversing Valve Operation

- ▶ Reversing valve energizes during heat mode and de-energizes in cool mode.



During a heat call on first time operation the unit will run about 1 minute in cooling to build up pressure for reversing valve to change.



### 13.6 Protection Functions

- ▶ Outdoor coil temperature protection (T3)
  - i. If  $T3 > 143.6^{\circ}\text{F}$ , compressor is de-energized.
  - ii. If  $T3 < 129.2^{\circ}\text{F}$ , compressor is energized.
- ▶ Ambient temperature protection (T4)
  - i. If  $23^{\circ}\text{F} \leq T4 < 125^{\circ}\text{F}$ , unit can operate in cooling.
  - ii. If  $-4^{\circ}\text{F} \leq T4 < 86^{\circ}\text{F}$ , unit can operate in heating.
  - iii. If  $T4 < -4^{\circ}\text{F}$ , heat pump will provide 24V control to indoor unit energizing electric heat (if installed).



See Product Specification for extended performance data.

- ▶ Discharge Temperature (DT) protection (T5)
  - i. If  $DT > 230^{\circ}\text{F}$  during cooling mode, the compressor will stop.
  - ii. If  $DT < 212^{\circ}\text{F}$  during cooling mode, the compressor will restart.
  - iii. If  $DT > 230^{\circ}\text{F}$  during heating mode, the compressor will stop.
  - iv. If  $DT < 212^{\circ}\text{F}$  during heating mode, the compressor will restart.
- ▶ High Pressure (HP) protection (mechanical open/close pressure switch)
  - i. High Pressure Switch opens at  $P > 580$  PSIG, the compressor and outdoor fan stop.
  - ii. High Pressure Switch closes at  $P < 435$  PSIG, the compressor and outdoor fan restart.
- ▶ Low Pressure (LP) protection
  - i. If Low Pressure  $< 43.5$  PSI for 5 minutes during cooling mode, the compressor and outdoor fan will stop. The system will attempt to run again after 6 minutes.
  - ii. If condensing temp.  $T_c < \text{outdoor ambient temp. } T_4$  during heating mode, the compressor and outdoor fan will stop.
- ▶ Module (inverter) protection (TF)
  - i. If  $TF > 172^{\circ}\text{F}$ , the compressor and outdoor fan will stop.
  - ii. If  $TF < 160^{\circ}\text{F}$ , the compressor and outdoor fan will restart.



### 13.7 Fault Code Table

Outdoor Control Board Code	Fault Description (Sensor)
C3	The coil sensor is seated fault in cooling (T3)
E4	Temperature sensor fault (T3, T4, T5, Th, T3L)
E5	High/low voltage protection
E6	DC fan motor fault
E7	Compressor discharge sensor is seated fault (T5)
E9	EEPROM
H0	Communication fault in main control chip
H5*	5 times (P2) protection in 100 minutes, system lockup
H8	Pressure transducer fault (PT)
P0	High module radiator temperature protection (TF)
P1	High pressure switch protection (HPS)
P2	Low pressure protection in cooling or heating (PT)
P3	Compressor over current protection
P4	High compressor discharge temperature protection (T5)
P5	Condensor coil temperature protection in cooling (T3)
P8	DC fan motor typhoon protection
PH	Low discharge superheat protection
F1	High pressure switch (HPS) fault
L0-L9	IPM module protection

#### System Protection Status Codes\*\*

┆	Forced operation mode
L	Running indication under T3 limited condition
D	Running indication under T5 limited condition
P	Running indication under compressor ratio limited condition
F	Running indication under TF limited condition
C	Running indication under current limited condition
U	Running indication under low voltage limited condition
A	Running indication under return oil model
dF	Running indication under defrost model

Table 19

\* Fault requires hard restart

\*\* If the first digit shown on the control board LED is one of the following protection codes (followed by two numerical digits which show the current compressor frequency in Hz), the unit will continue to run but in a limited condition. The only exception is when the system is in defrost mode, which only displays "dF" (without any numerical digits following).

#### Indoor Unit Board LED Codes

Number of flashes	Description
Always ON	Normal
1	Dehumidification mode active
2	Reserved
3	Anti-cold air function active
4	Temperature sensor fault (T1)
5	Temperature sensor fault (T2)
6	Communication error

Table 20

### 13.8 Parameter Point Check Table

- ▶ To display system parameters, press the “Check” button to index through the series of parameters available. The first time you press the “Check” button, it will display the sequence, and after 1 second it will display the value of the parameter. If you press the “Check” button again, it will display the next sequence. Refer to Figure 32 for check button location on the control board.

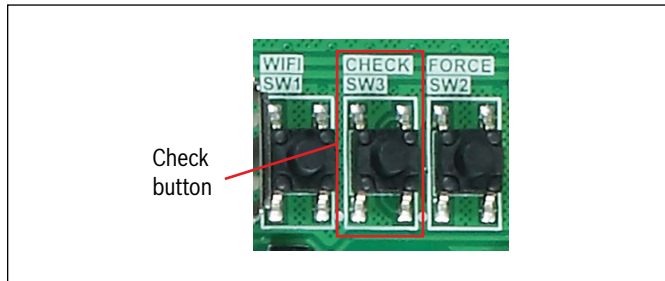

Figure 31

- ▶ Normal Status, last two digits will display under the following conditions
  - Unit not operating (Standby Mode); “outdoor ambient temperature”.
  - Unit operating; displays “compressor operating frequency”.
- ▶ After 20 seconds on same parameter, the display will revert back to normal status.
- ▶ If a system protection is active, first digit will display “status code”.



SW1 is not used. See Figure 31.

No.	Point check content	Example	Remark
0	Outdoor unit capacity	H3	H3=Heat pump 3 ton
1	Outdoor unit mode	2	0 standby 2 cooling 3 heating
2	Outdoor unit set compressor speed (Hz)	66	
3	T3 (outdoor coil temp.) (°F)		
4	T4 (outdoor ambient temp.) (°F)		
5	T5 (compressor discharge temp.) (°F)		
6	Th (compressor suction temp.) (°F)		
7	T3L (Condenser outlet temp.) (°F)		
8	Tf (module temp.) (°F)		
9	Pe (evaporating pressure) (PSI)		Low Suction Pressure
10	Pc (condensing pressure) (PSI)		High Head Pressure
11	Tes (target of the evaporating temp.) (only use for cooling mode) (°F)		
12	Te (evaporating temp.) (°F)		
13	Tcs target of the condensing temp. (only use for heating mode) (°F)		
14	Tc (condensing temp.) (°F)		
15	Target of the compressor discharge superheat (only use for heating mode) (°F)		
16	Compressor discharge superheat (°F)		
17	Openings of EEV		
18	Outdoor Fan speed		
19	Compressor current (A)		
20	Power AC voltage Input (V)		
21	Compressor input dc voltage (V)		
22	Continuous running time of the compressor (min)		
23	Last Fault Code		see Table 19
24	Software version		
25	T1 (Return air temp) (°F)		Only valid for 3T
26	T2 (Indoor coil temp) (°F)		Only valid for 3T
27	Indoor blower motor speed		Only valid for 3T
28	Ts (Estimated thermostat set point) (°F)		Only valid for 3T
29	Remark"-"		

Table 21

### 13.9 Control Board Overview

#### Outdoor Unit Control Board for 3 Ton Model

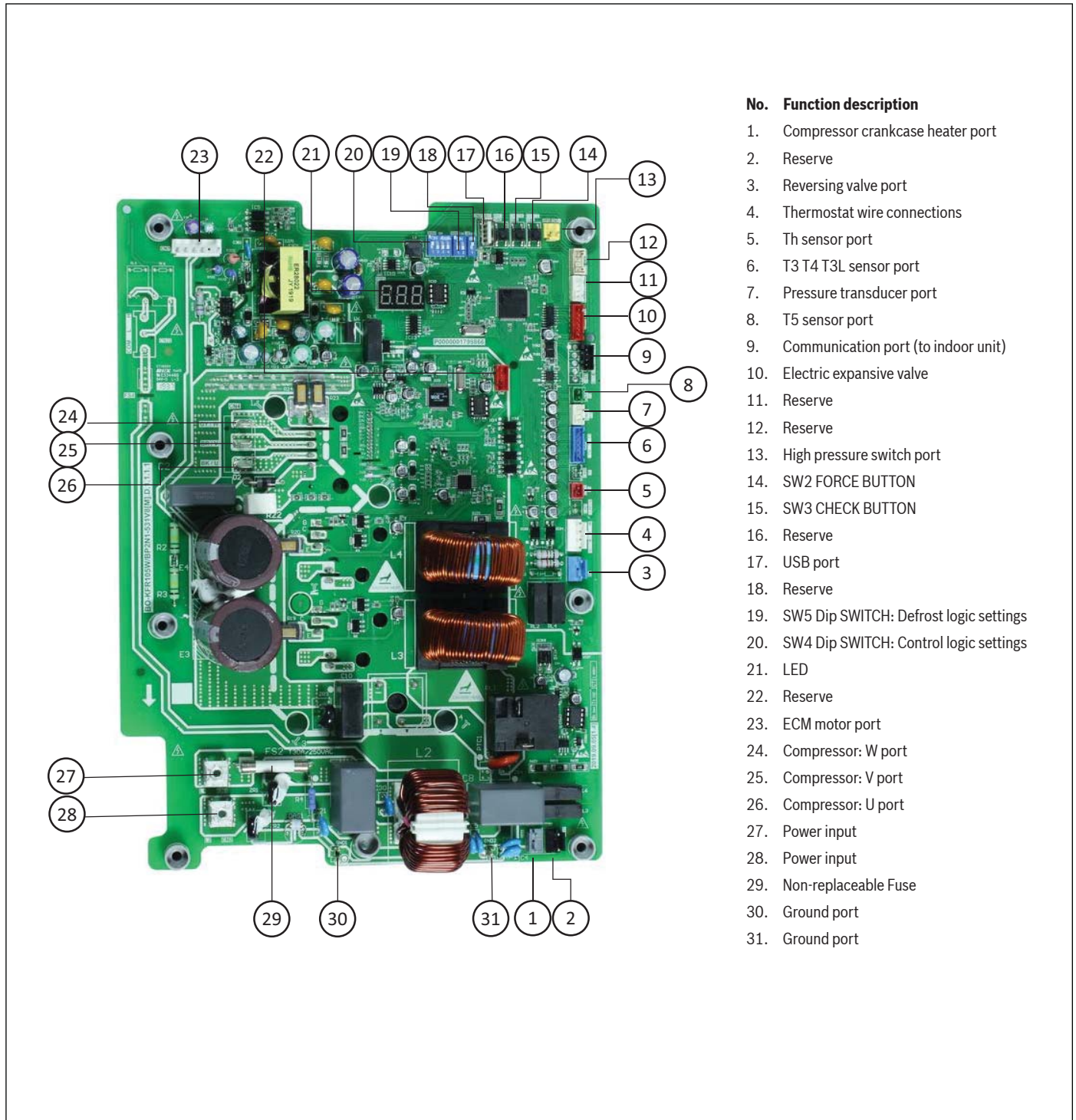

- | No. | Function description                   |
|-----|--|
| 1.  | Compressor crankcase heater port       |
| 2.  | Reserve                                |
| 3.  | Reversing valve port                   |
| 4.  | Thermostat wire connections            |
| 5.  | Th sensor port                         |
| 6.  | T3 T4 T3L sensor port                  |
| 7.  | Pressure transducer port               |
| 8.  | T5 sensor port                         |
| 9.  | Communication port (to indoor unit)    |
| 10. | Electric expansive valve               |
| 11. | Reserve                                |
| 12. | Reserve                                |
| 13. | High pressure switch port              |
| 14. | SW2 FORCE BUTTON                       |
| 15. | SW3 CHECK BUTTON                       |
| 16. | Reserve                                |
| 17. | USB port                               |
| 18. | Reserve                                |
| 19. | SW5 Dip SWITCH: Defrost logic settings |
| 20. | SW4 Dip SWITCH: Control logic settings |
| 21. | LED                                    |
| 22. | Reserve                                |
| 23. | ECM motor port                         |
| 24. | Compressor: W port                     |
| 25. | Compressor: V port                     |
| 26. | Compressor: U port                     |
| 27. | Power input                            |
| 28. | Power input                            |
| 29. | Non-replaceable Fuse                   |
| 30. | Ground port                            |
| 31. | Ground port                            |

Figure 32

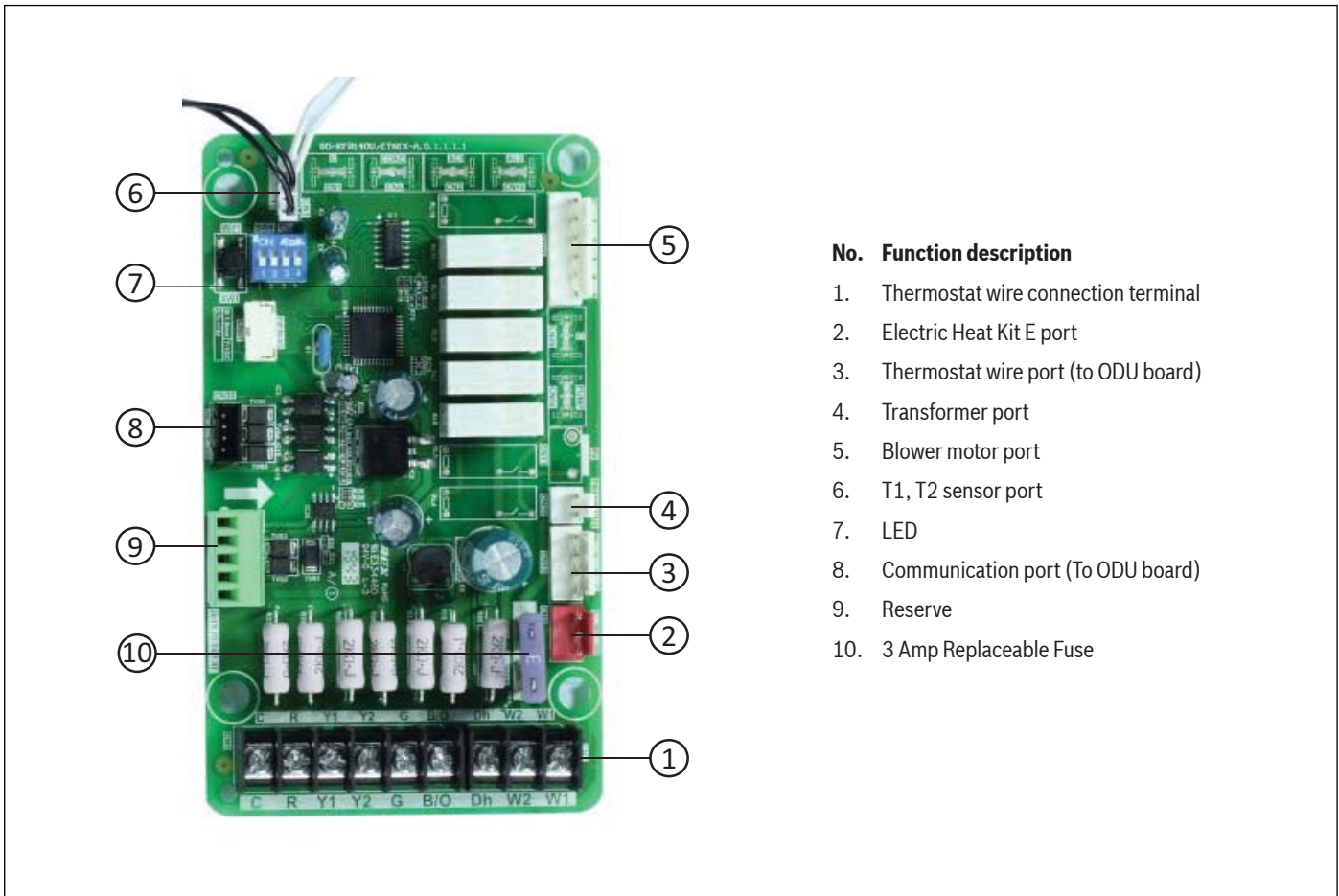
**Indoor Unit Control Board for 3 Ton Model****No. Function description**

1. Thermostat wire connection terminal
2. Electric Heat Kit E port
3. Thermostat wire port (to ODU board)
4. Transformer port
5. Blower motor port
6. T1, T2 sensor port
7. LED
8. Communication port (To ODU board)
9. Reserve
10. 3 Amp Replaceable Fuse

Figure 33

13.10 Error Code Troubleshooting (ODU)

Error Code	Description (Sensor)
P1	High pressure switch (HPS) protection
P5	Condenser coil temperature (T3) protection in cooling
P3	Compressor over current protection

Table 22

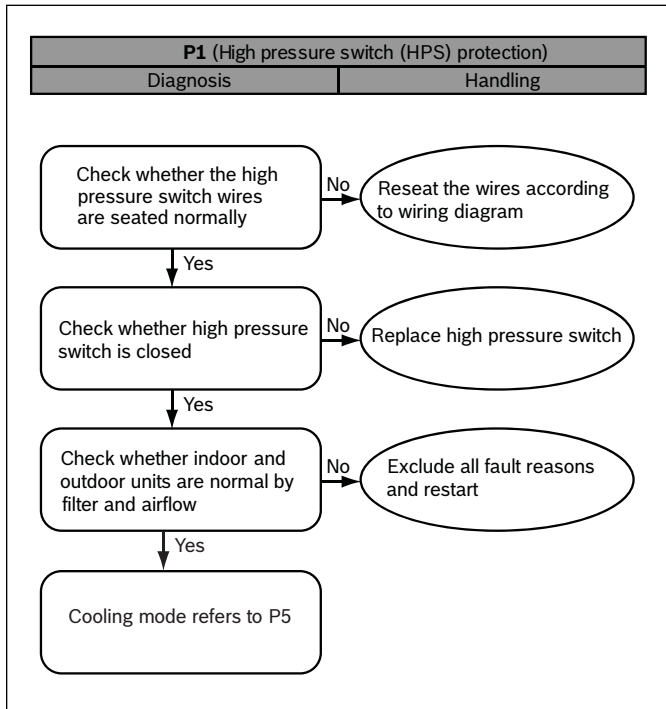

Figure 34

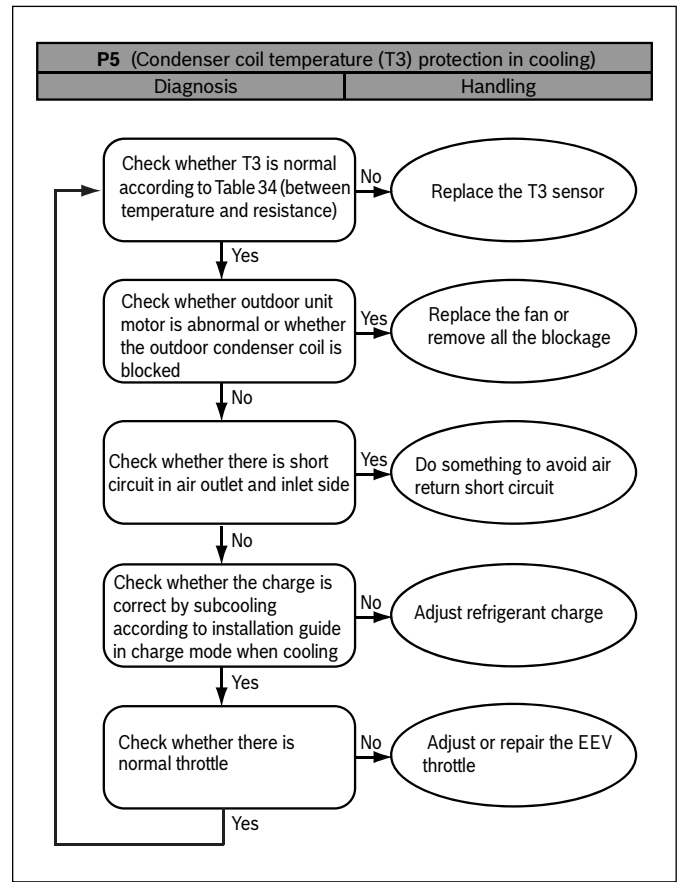

Figure 35

Error Code	Description
P2	Low pressure (PT) Protection in cooling and heating
H5	System lockup, 5 times (P2) protection in 100 minutes
P4	High compressor discharge temperature(T5)

Table 24

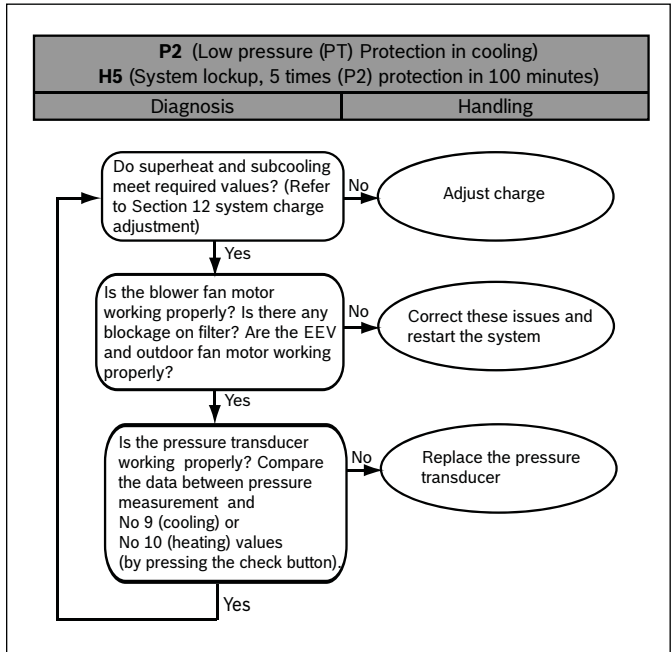

Figure 38

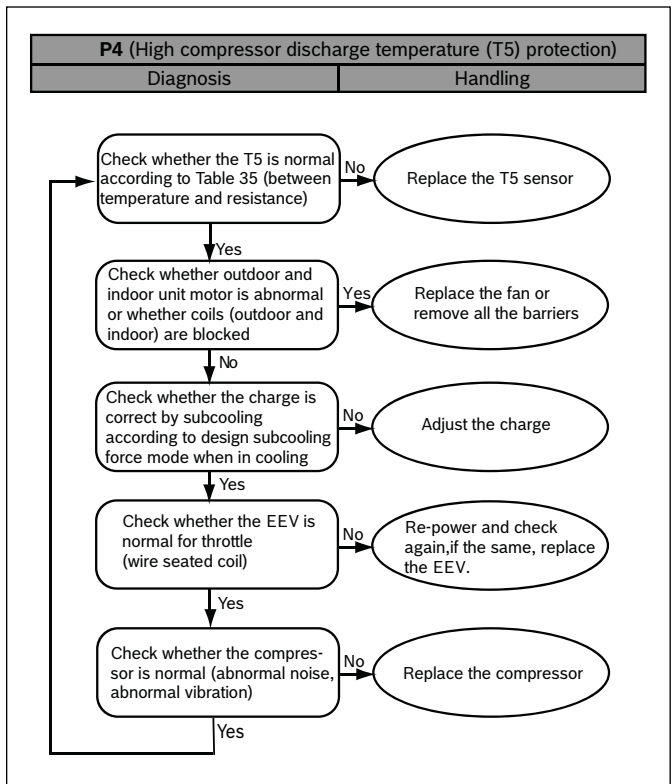

Figure 39

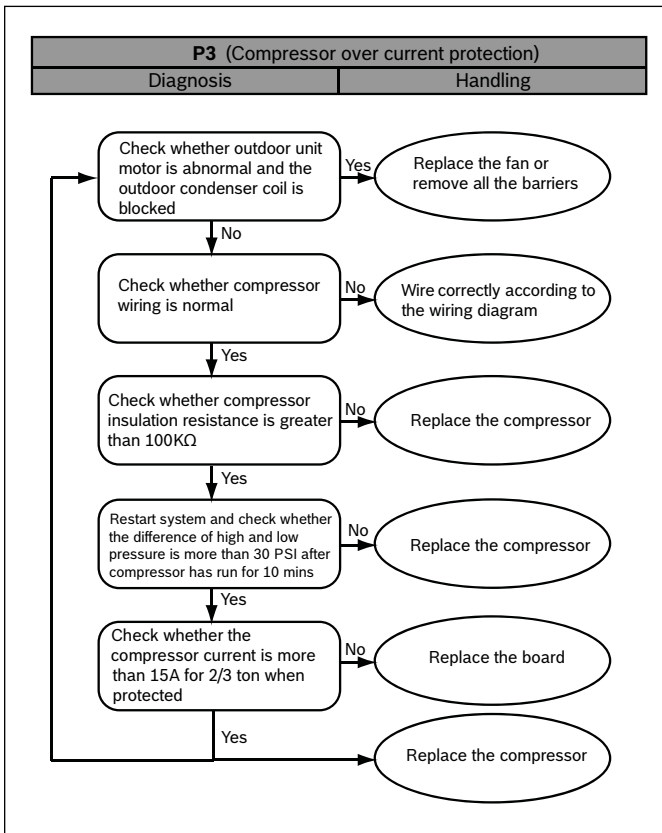

Figure 36

Error Code	Description
P0	High module radiator temperature (TF) protection

Table 23

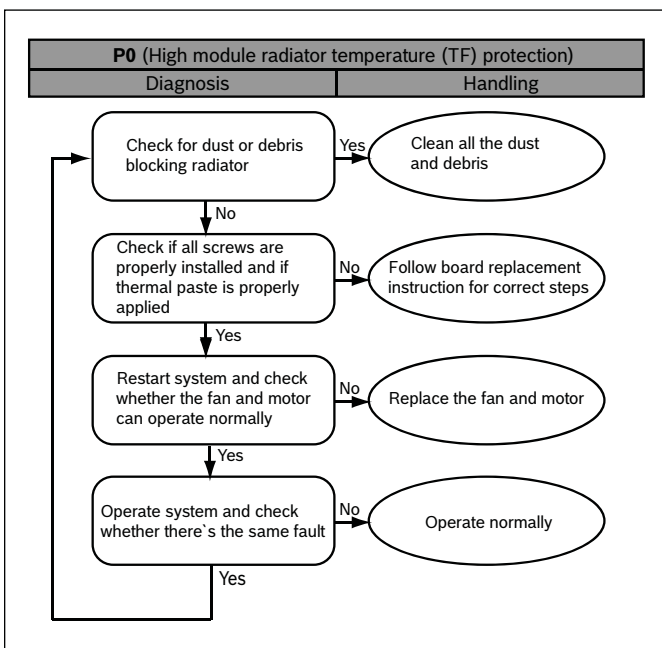

Figure 37

Error Code	Description
E4	Temperature sensor fault (T3, T4, T5, Th, T3L)
H8	Pressure transducer (PT) fault
F1	High pressure switch (HPS) fault

Table 25

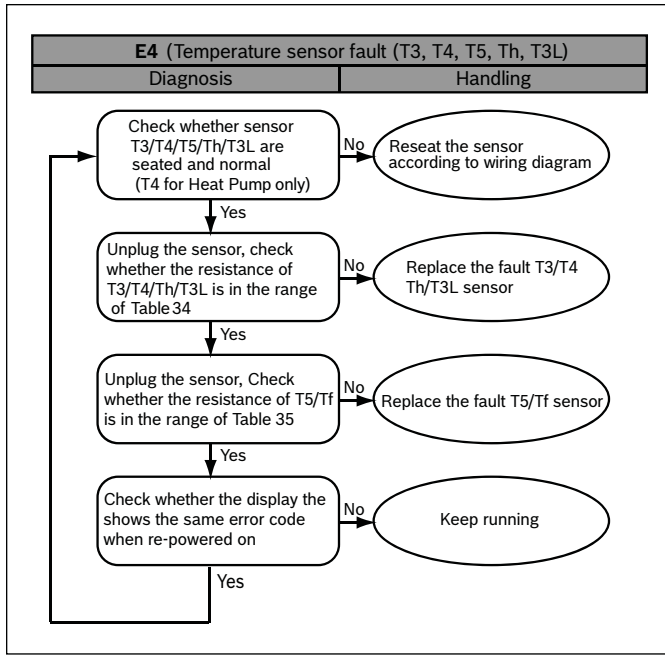

Figure 40

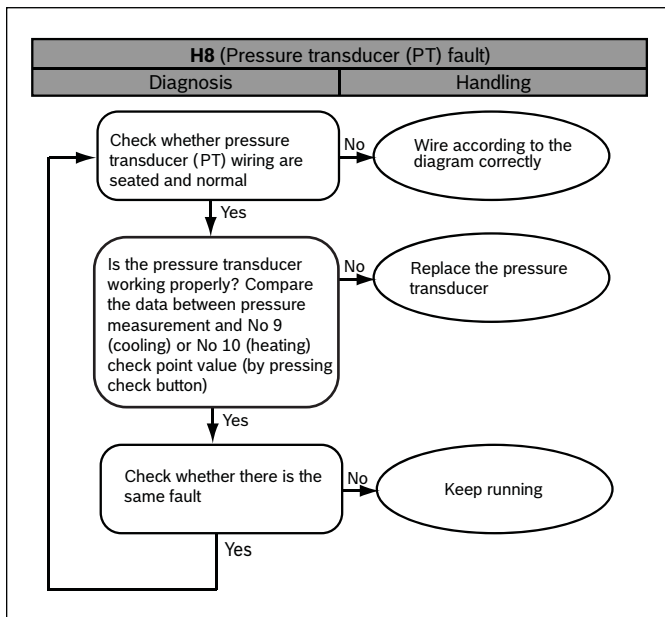

Figure 41

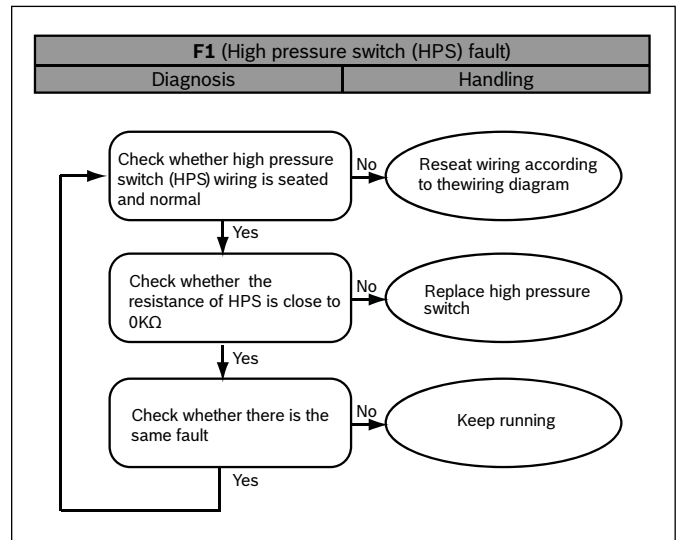

Figure 42



Error Code	Description
C3	Condenser coil sensor (T3) is seated fault in cooling
E7	Compressor discharge sensor (T5) is seated fault

Table 26

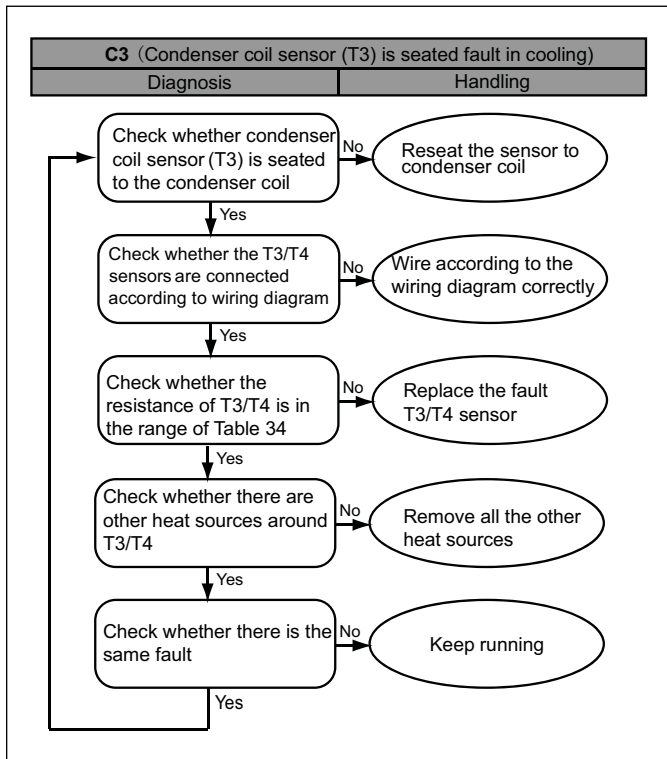

Figure 43

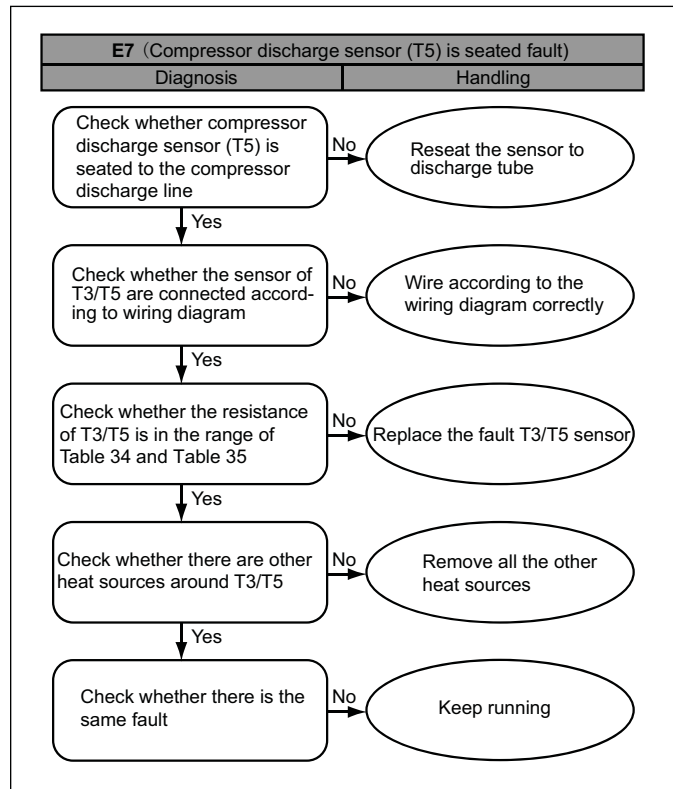

Figure 44

Error Code	Description
E6	DC fan motor fault

Table 27

If the E6 error code appears occasionally, no action is necessary. The system will restart automatically after 6 minutes.

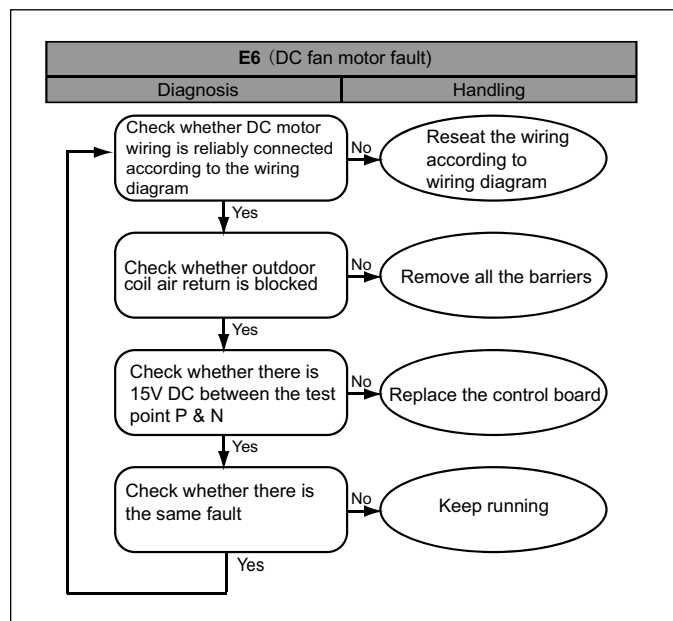

Figure 45



Error Code	Description
E9	EEPROM fault
H0	Communication fault in main control chip
E5	High/low voltage protection

Table 28

If error codes E9/H0/E5 appear occasionally and after the system restarts and runs normally after the power supply is re-established, no action is necessary. Otherwise the system must be checked.

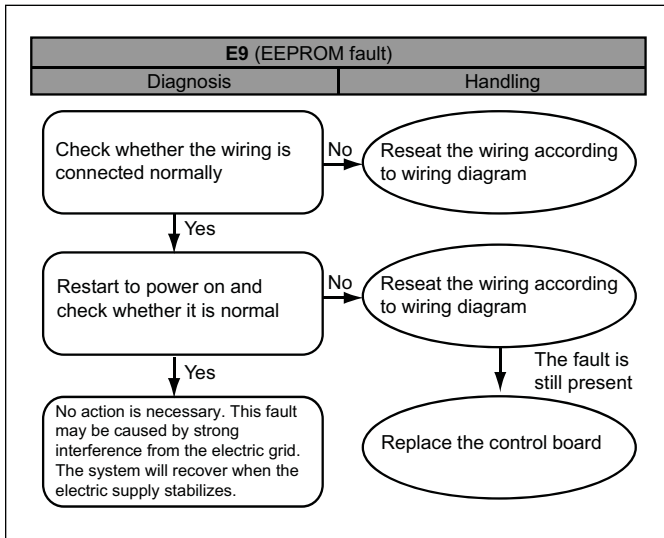

Figure 46

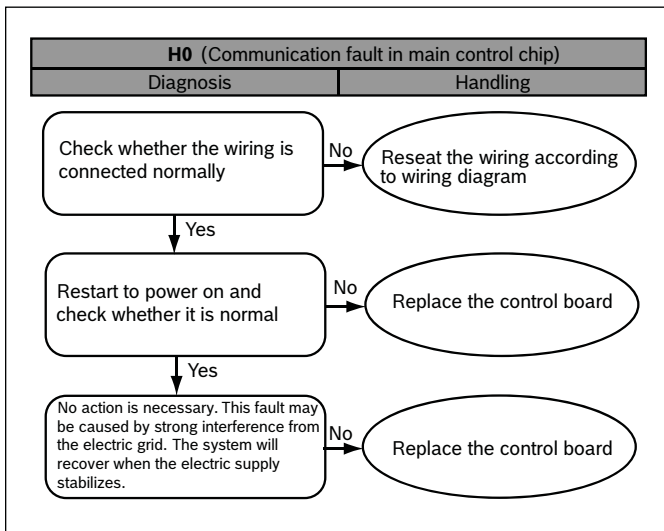

Figure 47

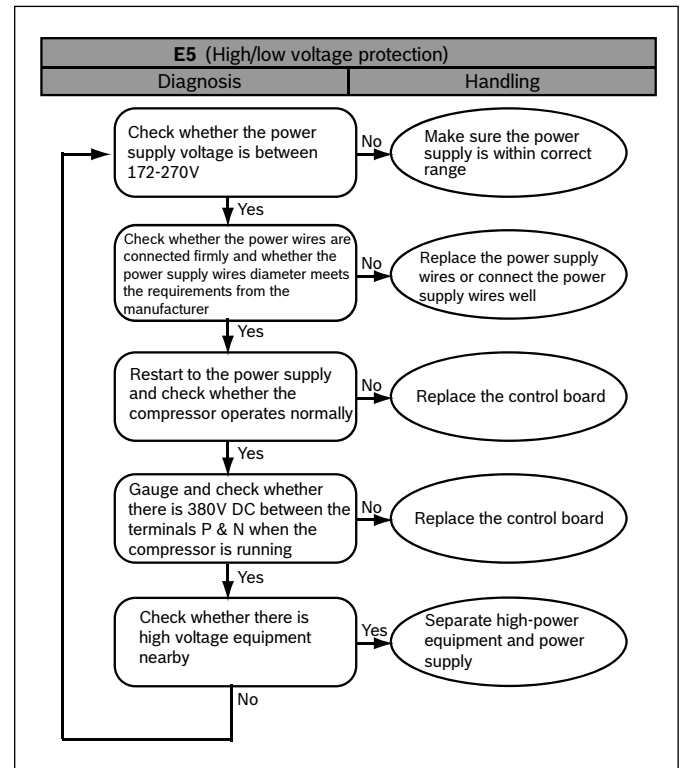

Figure 48

Error Code	Description
L0-L9	IPM module protection

Table 29

When error codes L0-L9 appears occasionally, no action is necessary. The system will restart automatically after 6 minutes. Please follow the steps below if L0-L9 appears frequently.

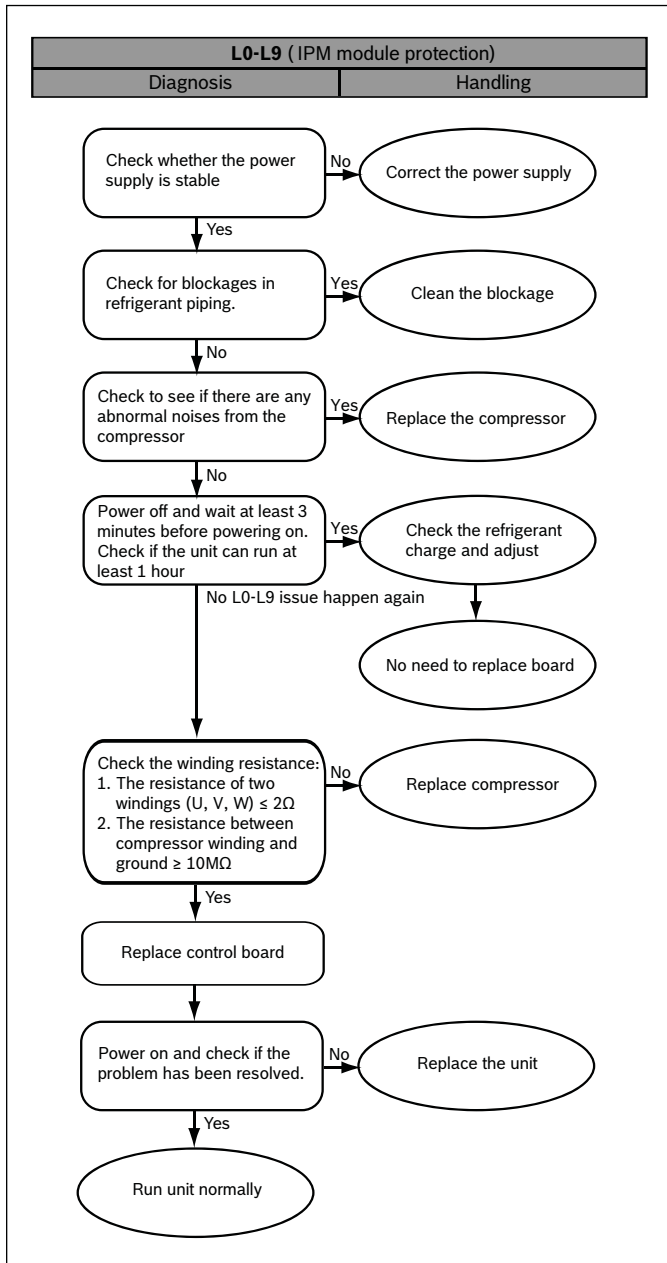

Figure 49

Error Code	Description
AtL	Ambient Temperature Limited

Table 30

**i** When the ambient temperature returns to within the operating range, the system will recover automatically.

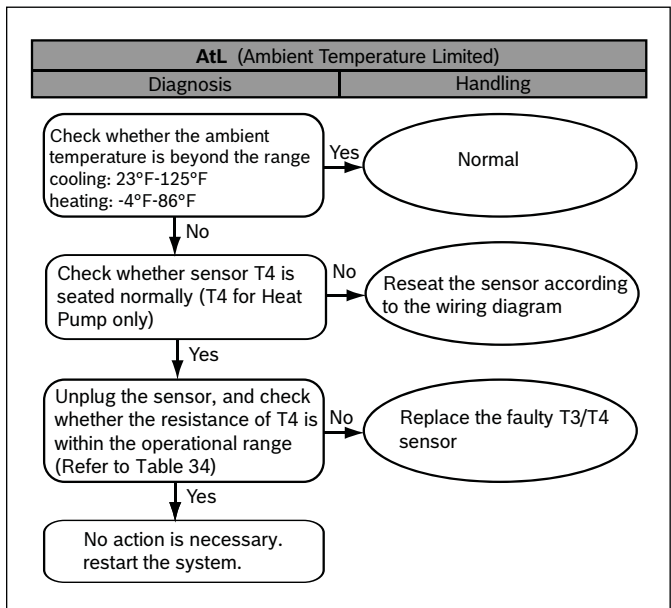

Figure 50

Error Code	Description
/	No display on control board

Table 31

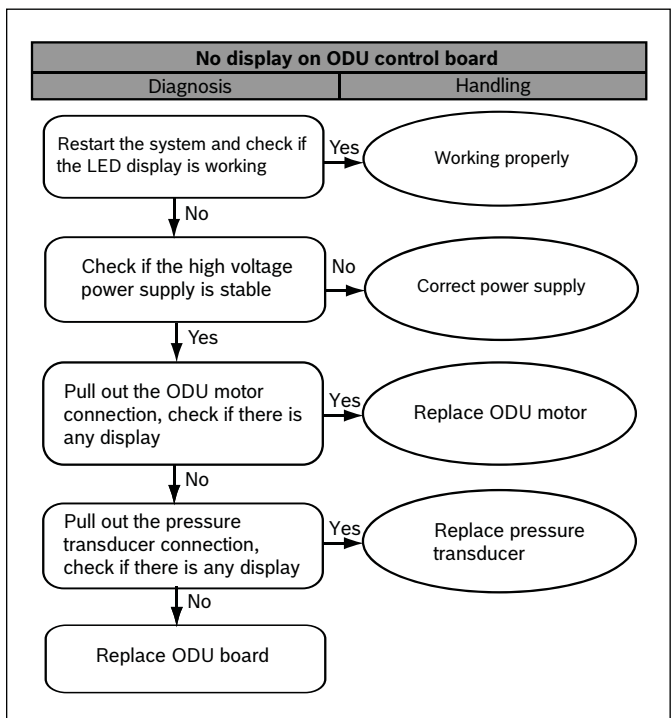

Figure 51

### 13.11 Error Code Troubleshooting (IDU)

Number of flashes	Description (Sensor)
4	Temperature sensor fault (T1)
5	Temperature sensor fault (T2)

Table 32

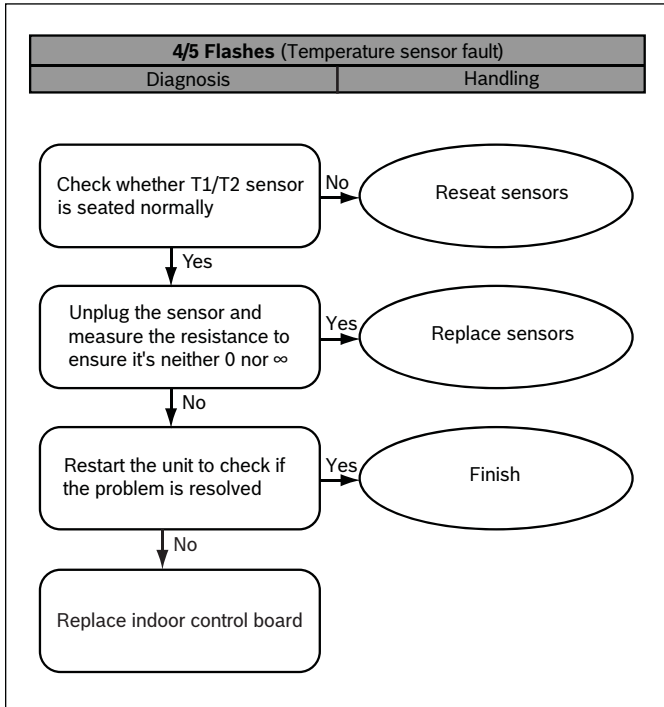

Figure 52

Number of flashes	Description (Sensor)
6	Communication error

Table 33

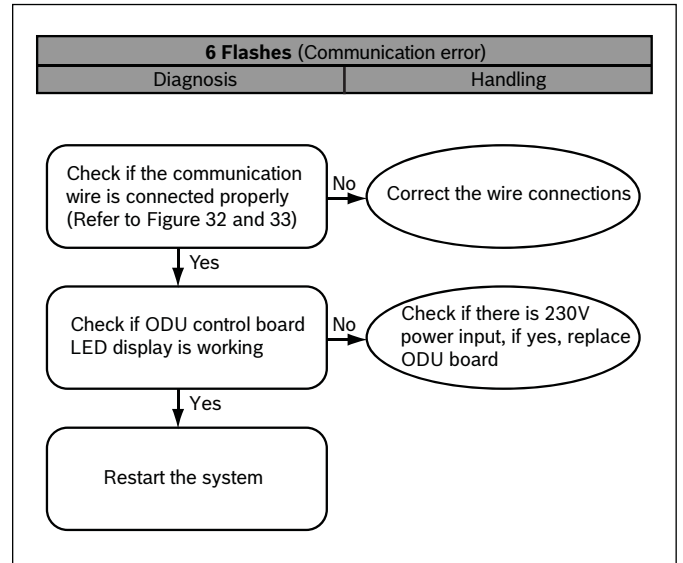

Figure 53

**13.12 Temperature and Resistance Relationship Tables (for Sensors)**

TEMP F	TEMP C	RESISTANCE kΩ	VOLTS DC	TEMP F	TEMP C	RESISTANCE kΩ	VOLTS DC
-5	-20.6	107.732	4.65	90	32.2	7.225	2.36
0	-17.8	93.535	4.60	95	35.0	6.401	2.21
5	-15.0	79.521	4.54	100	37.8	5.683	2.07
10	-12.2	67.795	4.47	105	40.6	5.057	1.93
15	-9.4	57.948	4.39	110	43.3	4.509	1.79
20	-6.7	49.652	4.30	115	46.1	4.028	1.67
25	-3.9	42.645	4.21	120	48.9	3.606	1.55
30	-1.1	36.710	4.10	125	51.7	3.233	1.43
40	4.4	27.386	3.86	130	54.4	2.902	1.32
45	7.2	23.732	3.73	135	57.2	2.610	1.22
50	10.0	20.610	3.59	140	60.0	2.350	1.13
55	12.8	17.939	3.45	145	62.8	2.119	1.04
60	15.6	15.648	3.30	150	65.6	1.914	0.96
65	18.3	13.681	3.15	155	68.3	1.731	0.88
70	21.1	11.987	2.99	160	71.1	1.574	0.82
75	23.9	10.527	2.83	165	73.9	1.416	0.75
80	26.7	9.265	2.67	170	76.7	1.276	0.68
85	29.4	8.172	2.52				

Table 34 for T3, T4, Th, T3L, T1, T2

**13.13 Temperature and Resistance Relationship Tables (for T5)**

TEMP F	TEMP C	RESISTANCE kΩ	VOLTS DC	TEMP F	TEMP C	RESISTANCE kΩ	VOLTS DC
-5	-20.6	600.134	4.93	140	60.0	13.643	3.14
0	-17.8	505.551	4.92	145	62.8	12.359	3.03
5	-15.0	427.463	4.91	150	65.6	11.214	2.91
10	-12.2	362.739	4.89	155	68.3	10.227	2.80
15	-9.4	308.891	4.87	160	71.1	9.308	2.68
20	-6.7	265.398	4.85	165	73.9	8.485	2.56
25	-3.9	227.481	4.83	170	76.7	7.746	2.45
30	-1.1	195.601	4.80	175	79.4	7.105	2.34
35	1.7	168.707	4.77	180	82.2	6.504	2.23
40	4.4	146.695	4.74	185	85.0	5.963	2.13
45	7.2	127.258	4.70	190	87.8	5.474	2.02
50	10.0	110.707	4.66	195	90.6	5.032	1.92
55	12.8	96.572	4.61	200	93.3	4.645	1.83
60	15.6	84.465	4.56	205	96.1	4.28	1.73
65	18.3	74.411	4.51	210	98.9	3.949	1.64
70	21.1	65.408	4.45	215	101.7	3.648	1.56
75	23.9	57.634	4.39	220	104.4	3.383	1.48
80	26.7	50.904	4.32	225	107.2	3.133	1.40
85	29.4	45.258	4.24	230	110	2.904	1.32
90	32.2	40.152	4.16	235	112.8	2.694	1.25
95	35.0	35.699	4.08	240	115.6	2.503	1.18
100	37.8	31.807	3.99	245	118.3	2.334	1.12
105	40.6	28.398	3.89	250	121.1	2.172	1.06
110	43.3	25.506	3.80	255	123.9	2.024	1.00
115	46.1	22.861	3.70	260	126.7	1.888	0.95
120	48.9	20.529	3.59	265	129.4	1.767	0.90
125	51.7	18.47	3.48	270	132.2	1.651	0.85
130	54.4	16.708	3.37	275	135.0	1.544	0.80
135	57.2	15.085	3.26	280	137.8	1.446	0.76

Table 35 for T5

13.14 Wiring Diagram

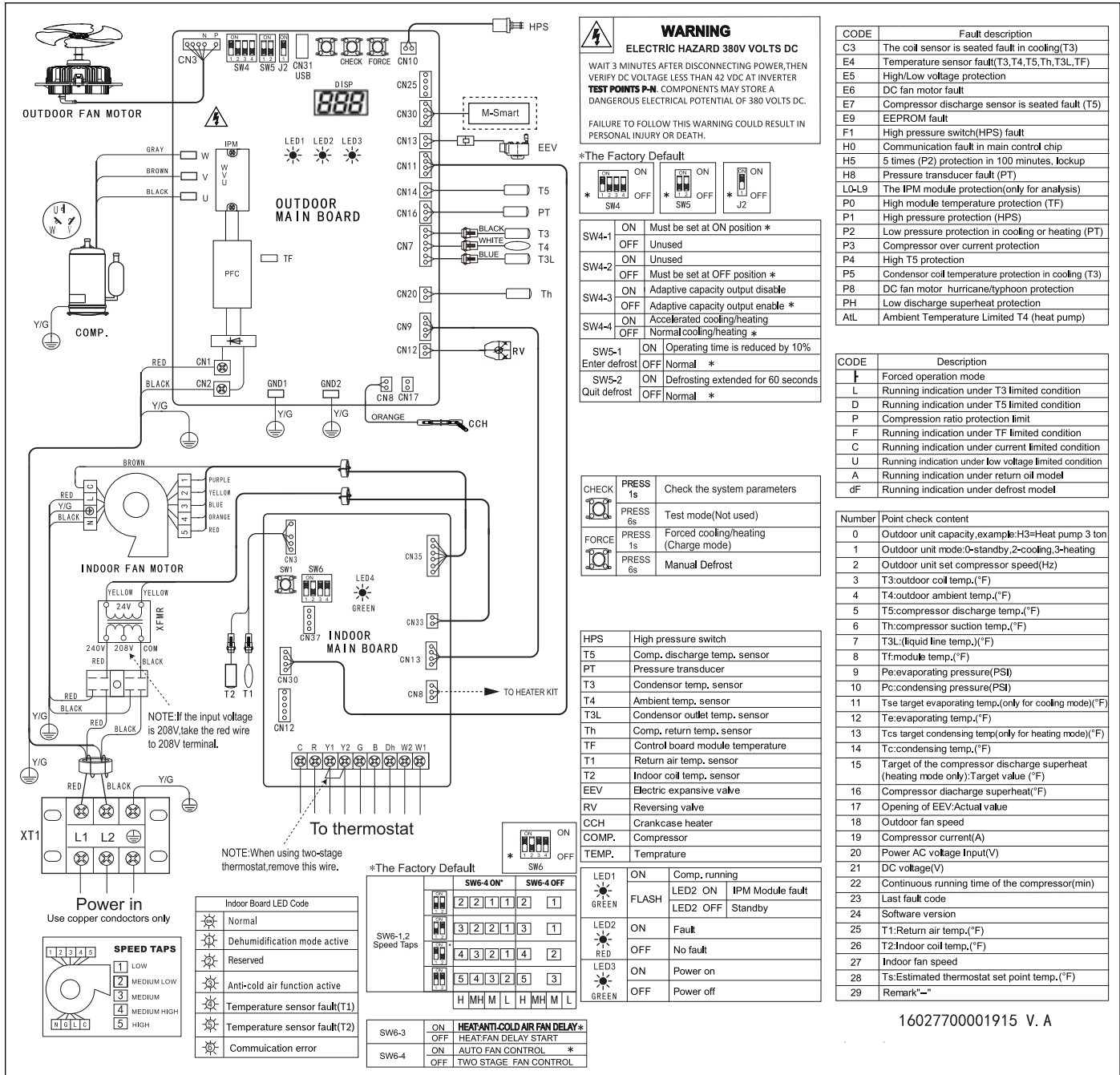

Figure 54

## 14 Maintenance



For continuing high performance and to minimize possible equipment failure, periodic maintenance must be performed on this equipment.

### 14.1 Cleaning Precautions



**WARNING:**

- ▶ Any unit repairs must be performed by qualified service personnel only.



**WARNING: ELECTRICAL SHOCK**

- ▶ Always turn off your heat pump and disconnect its power supply before cleaning or maintenance.



**CAUTION:**

- ▶ When removing filter, do not touch metal parts in the unit. The sharp metal edges can cut you.



**NOTICE:**

- ▶ Do not use chemicals or chemically treated cloths to clean the unit .
- ▶ Do not use benzene, paint thinner, polishing powder or other solvents to clean the unit.
- ▶ Do not operate the system without a filter in place

### 14.2 Regular Maintenance

Your heat pump must be inspected regularly by a qualified service technician.

1. Inspect the air filter every ninety days or as often as needed. If blocked or obstructed, clean or replace at once.

**Your annual system inspection must include:**

2. Inspection and/or cleaning of the blower wheel housing and motor.
3. Inspection and cleaning of indoor and outdoor coils as required.
4. Inspection and/or cleaning of the indoor coil drain pan and drain lines, as well as auxiliary drain pan and lines.
5. Check all electrical wiring and connections. Correct as needed, referring to the wiring diagram. (Refer to Figure 54)

**United States**

**Bosch Thermotechnology Corp.**  
**65 Grove Street**  
**Watertown, MA 02472**

**Tel: 866-642-3198**  
**Fax: 603-965-7581**  
**[www.boschheatingandcooling.com](http://www.boschheatingandcooling.com)**