

Bosch Inverter Ducted Packaged Heat Pump

19 SEER Series (5 Ton Capacity)

18.5 SEER Series (3 Ton Capacity)

R410A



BOSCH

Product Specifications



Table of Contents

1 Product Features	4
1.1 Features and Benefits	4
1.2 Standard Features	4
1.3 Cabinet Features	4
1.4 Limited Warranty	4
2 Nomenclature	5
3 Product Specifications	6
4 AHRI 210/240 Performance Data	7
5 Extended Performance Data	8
5.1 BRB-60HWD1N1-M19 For Cooling	8
5.2 BRB-60HWD1N1-M19 For Heating	9
5.3 BRB-36HWD1N1-M18 For Cooling	10
5.4 BRB-36HWD1N1-M18 For Heating	11
6 Airflow Performance	12
7 Sound Data	13
8 Electrical Data	13
9 Dimensions	14
9.1 BRB-60HWD1N1-M19 Unit Dimensions	14
9.2 BRB-60HWD1N1-M19 Dimensions - Back and Bottom	15
9.3 BRB-60HWD1N1-M19 Dimensions - Right and Top	16
9.4 BRB-36HWD1N1-M18 Unit Dimensions	17
9.5 BRB-36HWD1N1-M18 Dimensions - Back and Bottom	18
9.6 BRB-36HWD1N1-M18 Dimensions - Right and Top	19
10 Rooftop Installation - Curb Mounting	20
11 Wiring Diagram	22
11.1 BRB-60HWD1N1-M19 Wiring Diagram	22
11.2 BRB-36HWD1N1-M18 Wiring Diagram	23

1 Product Features

1.1 Features and Benefits

- ▶ Superior efficiency
 - IDP 3T rated at 18.5 SEER, 12 EER, 9 HSPF
 - IDP 5T rated at 19 SEER, 12.5 EER, 10 HSPF
- ▶ Fully modulating Inverter Drive precisely matches the heating/cooling load
- ▶ Inverter Compressor (36%-118% speed), modulation in 1% increments
- ▶ IDP 3T - Provides up to 4-stage indoor fan control, mobile home certified for high static
- ▶ IDP 5T - Provides up to 2-stage indoor fan control
- ▶ 2-way design allows for horizontal and downflow installations, air return/supply are convertible
- ▶ Easy to install – compatible with most standard 24 VAC heat pump thermostats

1.2 Standard Features

- ▶ R-410A Chlorine-Free Refrigerant
- ▶ Intelligent Oil Return Technology
- ▶ Inverter Driven Rotary Compressor
- ▶ Crankcase Heater Standard
- ▶ Compressor Sound Blanket
- ▶ Multiple System Protection:
 - High pressure switch and low pressure transducer
 - Compressor liquid return protection
 - Compressor high or low compression ratio protection
 - Compressor high temperature protection
 - High / low voltage protection and over current protection
 - IPM and electronic control board high temperature protection
- ▶ Outdoor coil is capable of withstanding 1000 hour salt spray test according to ASTM B117 standard
- ▶ AHRI certified; ETL listed

1.3 Cabinet Features

- ▶ Baked-on powder paint finish
- ▶ Wire fan discharge grille
- ▶ Steel louver coil guard

1.4 Limited Warranty

For Products installed in a one or two family residential dwelling BTC warrants that all compressors and internal components incorporated into the Product at the time of shipment by BTC shall remain free from defects in workmanship and materials for ten (10) years* from the Commencement Date. If the Warranty Registration process has been completed and BTC determines that the Product or any part of the Product has a defect in workmanship or materials, BTC shall pay labor charges associated with the repair or replacement of the part in accordance with the Warranty Labor Allowance Schedule** for the period of ninety (90) days from the Commencement Date.

For Products installed in a building other than a one or two family residential dwelling, BTC warrants that all compressors incorporated into the Product at the time of shipment by BTC shall remain free from defects in workmanship and materials for three (3) years* and other internal components incorporated into the Product components for one (1) year* from the Commencement Date

* Please refer to www.bosch-climate.us for full warranty terms and conditions.

** Warranty Labor Allowance Schedule details are available on www.boschprohvac.com

2 Nomenclature

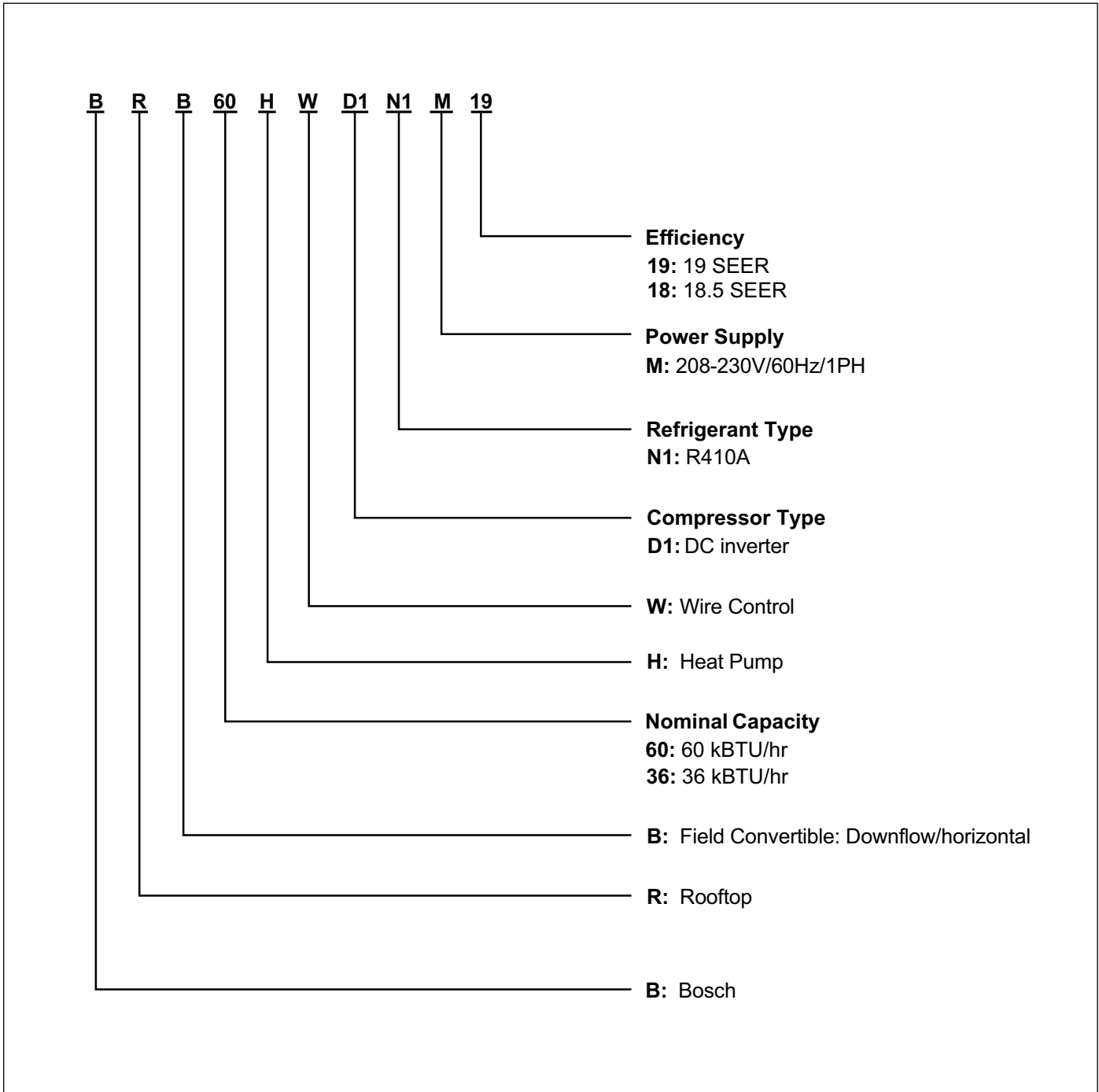

Figure 1

3 Product Specifications

	BRB-36HWD1N1-M18	BRB-60HWD1N1-M19
Electrical Data		
Rated Volts/Ph/Hz	208-230/1/60	208-230/1/60
Performance Cooling		
	23°F - 125 °F	23°F - 125°F
BTUH (High)	34800	57000
Indoor Airflow (CFM)	1250	1800
Power Input (KW)	2.9	4.56
SEER / EER-HI	18.5/12	19/12.5
Performance Heating		
	-4°F - 86°F	-4°F - 86°F
(High Temp.) BTUH / COP (High)	36000/3.7	57000/3.8
Power Input (KW)	2.88	4.4
HSPF (BTU / Watt-Hr.)	9	10
Power Conn. - V/Ph/Hz		
	208-230/1/60	208-230/1/60
Min. Brch. Cir. Ampacity ¹	28.7	41.9
Max. Overcurrent Protection ²	45	60
Min. / Max. Volts	172/270	172 / 270
Fuse Size - Max. / Recmd. (amps)	45	60
Compressor		
	Rotary	Rotary
Volts/Ph/Hz	208-230/1/60	208-230/1/60
R.L. Amps - L.R. Amps	19/52	27/52
Outdoor Coil - Type		
	Finned Tube Exchanger	Finned Tube Exchanger
Rows/F.P.I.	(3+2) / 17*	3/17
Face Area (sq.ft.)	14.11	20.17
Tube Size (in.)	9/32	9/32
Circuitry Type	Interlaced	Interlaced
Refrigerant Control	Electronic Expansion Valve	Electronic Expansion Valve
Indoor Coil - Type		
	Finned Tube Exchanger	Finned Tube Exchanger
Rows/F.p.i.	4 / 17	4 / 17
Face Area (Sq.ft.)	3.96	6.1
Tube Size (In.)	9/32	9/32
Circuitry Type	Interlaced	Interlaced
Drain Conn. Size (In.)	3/4 FEMALE NPT	3/4 FEMALE NPT
Outdoor Fan - Type		
	Propeller	Propeller
Dia. (in.)	23-5/8"	26-3/8"
Drive/No. Speeds	Direct / 10	Direct / 10
CFM @0.0 in. w.g.	3032	4100
Motor - HP/R.P.M.	1/3 / 200~880	1/3 / 200~880
Volts/Ph/Hz	208-230/1/60	208-230/1/60
F.L. Amps/L.R. Amps	1.4/1.4	2.1/2.1

Table 1

¹ Wire size should be determined in accordance with National Electrical Codes; extensive wire runs will require larger wire sizes.

² Must use time-delay fuses or HACR-type circuit breakers of the same size as noted.



There are two condenser coils, one has 3 rows, and the other has 2 rows.



Always check the rating plate for electrical data on the unit being installed.

	BRB-36HWD1N1-M18	BRB-60HWD1N1-M19
Indoor Fan - Type	Centrifugal	Centrifugal
Dia x Width (in.)	11 X 10-3/4"	11 X 10-5/8"
Drive/No. Speeds	Direct / 5	Direct / 5
CFM @0.0 in. w.g.	See Airflow Performance Table	See Airflow Performance Table
Motor - HP/R.P.M.	1/2 / 1050	3/4 / 1075
Volts/Ph/Hz	208-230/1/60	208-230/1/60
F.L. Amps/L.R. Amps	3.5 / 3.5	6.0 / 6.0
Filter / Furnished	No	No
Type Recommended	Throwaway	Throwaway
Recmd. Face Area (L x W x D)	16" x 10" x 1"	16" x 14" x 1"
Refrigerant / Charge (lbs. - oz.)	R410a / 7-8	R410a / 12 - 9
Dimensions		
Unit only L x W x H (in.)	50-11/16" x 35-1/16" x 46-13/16"	51-9/16" x 44-13/16" x 51-7/16"
Weight ³		
Net (lbs.)	412	561
Gross (lbs.)	432	596

Table 2

³ Weight values are estimated.



Always check the rating plate for electrical data on the unit being installed.

4 AHRI 210/240 Performance Data

Nominal HP System Tonnage	Heat Pump Model	Cooling Capacity (BTU/h)			Heating Capacity			CFM
		Total	EER ²	SEER ¹	Hi	HSPF ³	Low ⁴	
5	BRB-60HWD1N1-M19	57000	12.5	19	57000	10	44000	1800/1300
3	BRB-36HWD1N1-M18	34800	12	18.5	36000	9	23000	1250/950

Table 3

1 Seasonal Energy Efficiency Ratio; Certified per AHRI 210/240

2 Energy Efficiency Ratio; Certified per AHRI 210/240

3 HSPF = Heating Seasonal Performance Factor; Certified per AHRI 210/240

4 Jumper cut or dip switch off



Items in **bold** boxes meet the requirements for ENERGY STAR

5 Extended Performance Data

5.1 BRB-60HWD1N1-M19 For Cooling

BRB-60HWD1N1-M19 For Cooling																		
Indoor Airflow (SCFM)	Outdoor DB	IWB (°F)	59				63				67				71			
		IDB (°F)	70	75	80	85	70	75	80	85	70	75	80	85	70	75	80	85
1500	65	TC	40.8	41	41.2	41.4	48.4	48.6	48.8	49.1	55.5	55.8	56.1	56.4	\	65	65.4	65.7
		S/T	0.81	1.00	1.00	1.00	0.55	0.73	0.93	1.00	0.36	0.53	0.70	0.85	\	0.36	0.50	0.64
		kW	2.22	2.22	2.22	2.22	2.37	2.37	2.37	2.37	2.83	2.83	2.83	2.83	\	3.33	3.33	3.33
	75	TC	40.8	41	41.2	41.4	48.4	48.6	48.8	49.1	55.5	55.8	56.1	56.4	\	65	65.4	65.7
		S/T	0.81	1.00	1.00	1.00	0.55	0.73	0.93	1.00	0.36	0.53	0.70	0.85	\	0.36	0.50	0.64
		kW	2.68	2.68	2.68	2.68	2.88	2.88	2.88	2.88	3.48	3.48	3.48	3.48	\	4.09	4.09	4.09
	85	TC	40.8	41	41.2	41.4	48.4	48.6	48.8	49.1	55.5	55.8	56.1	56.4	\	65	65.4	65.7
		S/T	0.81	1.00	1.00	1.00	0.55	0.73	0.93	1.00	0.36	0.53	0.70	0.85	\	0.36	0.50	0.64
		kW	3.18	3.18	3.18	3.18	3.59	3.59	3.59	3.59	4.19	4.19	4.19	4.19	\	5.05	5.05	5.05
	95	TC	40.8	41	41.2	41.4	48.4	48.6	48.8	49.1	55.5	55.8	56.1	56.4	\	65	65.4	65.7
		S/T	0.81	1.00	1.00	1.00	0.55	0.73	0.93	1.00	0.36	0.53	0.70	0.85	\	0.36	0.50	0.64
		kW	3.54	3.54	3.54	3.54	4.29	4.29	4.29	4.29	5.05	5.05	5.05	5.05	\	5.96	5.96	5.96
	105	TC	40.8	41	41.2	41.4	48.4	48.6	48.8	49.1	54.4	54.7	55	55.3	\	57.5	57.8	58.1
		S/T	0.81	1.00	1.00	1.00	0.55	0.73	0.93	1.00	0.36	0.53	0.70	0.85	\	0.36	0.50	0.64
		kW	4.28	4.28	4.28	4.28	5.21	5.21	5.21	5.21	5.86	5.86	5.86	5.86	\	5.98	5.98	5.98
	115	TC	40.8	41	40.4	41.4	42.2	42.4	42.6	42.8	44.4	44.7	44.9	45.1	\	46.9	47.1	47.4
		S/T	0.81	1.00	1.00	1.00	0.57	0.79	0.98	1.00	0.40	0.59	0.78	0.95	\	0.37	0.56	0.78
		kW	4.98	4.98	4.98	4.98	5.14	5.14	5.14	5.14	5.3	5.3	5.3	5.3	\	5.46	5.46	5.46
1800	65	TC	41.5	41.7	41.9	42.1	49.1	49.4	49.6	49.9	56.4	56.7	57	57.3	\	66.1	66.4	66.8
		S/T	0.85	1.00	1.00	1.00	0.57	0.76	0.97	1.00	0.38	0.55	0.73	0.89	\	0.37	0.52	0.67
		kW	2.24	2.24	2.24	2.24	2.39	2.39	2.39	2.39	2.85	2.85	2.85	2.85	\	3.36	3.36	3.36
	75	TC	41.5	41.7	41.9	42.1	49.1	49.4	49.6	49.9	56.4	56.7	57	57.3	\	66.1	66.4	66.8
		S/T	0.85	1.00	1.00	1.00	0.57	0.76	0.97	1.00	0.38	0.55	0.73	0.89	\	0.37	0.52	0.67
		kW	2.7	2.7	2.7	2.7	2.9	2.9	2.9	2.9	3.51	3.51	3.51	3.51	\	4.12	4.12	4.12
	85	TC	41.5	41.7	41.9	42.1	49.1	49.4	49.6	49.9	46.4	56.7	57	57.3	\	66.1	66.4	66.8
		S/T	0.85	1.00	1.00	1.00	0.57	0.76	0.97	1.00	0.38	0.55	0.73	0.89	\	0.37	0.52	0.67
		kW	3.21	3.21	3.21	3.21	3.61	3.61	3.61	3.61	4.22	4.22	4.22	4.22	\	5.09	5.09	5.09
	95	TC	41.5	41.7	41.9	42.1	49.1	49.4	49.6	49.9	56.4	56.7	57	57.3	\	66.1	66.4	66.8
		S/T	0.85	1.00	1.00	1.00	0.57	0.76	0.97	1.00	0.38	0.55	0.73	0.89	\	0.37	0.52	0.67
		kW	3.20	3.20	3.20	3.20	3.90	3.90	3.90	3.90	4.56	4.56	4.56	4.56	\	5.41	5.41	5.41
	105	TC	51.5	41.7	41.9	42.1	49.1	49.4	49.6	49.9	55.3	55.6	55.9	56.1	\	58.4	58.7	59
		S/T	0.85	1.00	1.00	1.00	0.57	0.76	0.97	1.00	0.38	0.55	0.73	0.89	\	0.38	0.53	0.68
		kW	4.31	4.31	4.31	4.31	5.25	5.25	5.25	5.25	5.9	5.9	5.9	5.9	\	6.02	6.05	6.02
	115	TC	41.5	41.7	41	42.1	42.9	43.1	43.3	43.5	45.1	45.4	45.6	45.8	\	47.6	47.9	48.1
		S/T	0.85	1.00	1.00	1.00	0.60	0.82	1.00	1.00	0.42	0.62	0.81	0.99	\	0.39	0.58	0.81
		kW	5.02	5.02	5.02	5.02	5.18	5.18	5.18	5.18	5.34	5.34	5.34	5.34	\	5.5	5.5	5.5
1900	65	TC	42.1	42.3	42.5	42.7	49.9	50.2	50.4	50.7	57.3	57.6	57.9	58.2	\	67.1	67.5	67.8
		S/T	0.88	1.00	1.00	1.00	0.59	0.79	1.00	1.00	0.40	0.58	0.76	0.93	\	0.39	0.54	0.70
		kW	2.26	2.26	2.26	2.26	2.42	2.42	2.42	2.42	2.88	2.88	2.88	2.88	\	3.39	3.39	3.39
	75	TC	42.1	42.3	42.5	42.7	49.9	50.2	50.4	50.7	57.3	57.6	57.9	58.2	\	67.1	67.5	67.8
		S/T	0.88	1.00	1.00	1.00	0.59	0.79	1.00	1.00	0.40	0.58	0.76	0.93	\	0.39	0.54	0.70
		kW	2.72	2.72	2.72	2.72	2.93	2.93	2.93	2.93	3.55	3.55	3.55	3.55	\	4.16	4.16	4.16
	85	TC	42.1	42.3	42.5	42.7	49.9	50.2	50.4	50.7	57.3	57.6	57.9	58.2	\	67.1	67.5	67.8
		S/T	0.88	1.00	1.00	1.00	0.59	0.79	1.00	1.00	0.40	0.58	0.76	0.93	\	0.39	0.57	0.70
		kW	3.24	3.24	3.24	3.24	3.65	3.65	3.65	3.65	4.27	4.27	4.27	4.27	\	5.14	5.14	5.14
	95	TC	42.1	42.3	42.5	42.7	49.9	50.2	50.4	50.7	57.3	57.6	57.9	58.2	\	67.1	67.5	67.8
		S/T	0.88	1.00	1.00	1.00	0.59	0.79	1.00	1.00	0.40	0.58	0.76	0.93	\	0.69	0.54	0.70
		kW	3.6	3.6	3.6	3.6	4.37	4.37	4.37	4.37	5.14	5.14	5.14	5.14	\	6.07	6.07	6.07
	105	TC	42.1	42.3	42.5	42.7	49.9	50.2	50.4	50.7	57.3	57.6	57.9	58.2	\	59.3	59.6	59.9
		S/T	0.88	1.00	1.00	1.00	0.59	0.79	1.00	1.00	0.40	0.58	0.76	0.93	\	0.40	0.55	0.71
		kW	4.35	4.35	4.35	4.35	5.31	5.31	5.31	5.31	5.96	5.96	5.96	5.96	\	6.08	6.08	6.08
	115	TC	42.1	42.3	42.5	42.7	49.9	50.2	50.4	50.7	57.3	57.6	57.9	58.2	\	48.4	48.6	48.9
		S/T	0.88	1.00	1.00	1.00	0.59	0.79	1.00	1.00	0.40	0.58	0.76	0.93	\	0.40	0.60	0.85
		kW	5.07	5.07	5.07	5.07	5.24	5.24	5.24	5.24	5.4	5.4	5.4	5.4	\	5.56	5.56	5.56

Table 4

TC refers to total capacity S/T: refers to the ratio of sensible heat and total capacity kW: refers to total input power

5.2 BRB-60HWD1N1-M19 For Heating

BRB-60HWD1N1-M19 For Heating																	
Airflow (SCFM)	ID (°F)	OD (°F)	72	67	62	57	52	47	42	37	32	27	22	17	12	7	5
1500	60	TC	74.9	74.9	74.9	74.9	70.4	66.2	62.2	58.4	54.9	51.7	48.5	46.1	44.3	43.0	42.6
		kW	4.24	4.58	5.02	5.47	5.3	5.15	5.05	4.95	4.86	4.77	4.68	4.59	4.57	4.53	4.49
	70	TC	58.2	58.2	58.2	58.2	58.2	58.2	58.2	52.8	49.8	46.8	43.7	42.4	41.7	40.8	40.7
		kW	3.18	3.41	3.65	3.94	4.34	4.71	5.13	4.96	4.86	4.73	4.61	4.57	4.61	4.56	4.52
	75	TC	50.7	50.7	50.7	50.7	50.7	50.7	50.7	50.7	49.6	47.3	43.9	41.7	40.4	40.0	39.9
		kW	2.91	3.07	3.27	3.52	3.81	4.16	4.51	4.9	5.18	5.21	5.01	4.87	4.83	4.81	4.75
	80	TC	40.5	40.5	40.5	40.5	40.5	40.5	40.5	40.5	40.5	40.5	40.5	39.6	37.9	37.6	37.5
		kW	2.39	2.52	2.67	2.86	3.08	3.27	3.57	3.9	4.18	4.42	4.65	4.72	4.74	4.7	4.64
1800	60	TC	70.7	70.7	70.7	70.7	66.5	62.5	58.7	55.2	51.9	48.8	45.9	43.6	41.8	40.6	40.2
		kW	4.22	4.55	4.99	5.44	5.27	5.13	5.02	4.92	4.83	4.74	4.66	4.57	4.55	4.51	4.46
	70	TC	57.0	57.0	57.0	57.0	57.0	57.0	57.0	51.7	48.7	45.8	42.8	41.5	40.6	39.8	39.7
		kW	3.16	3.39	3.63	3.92	4.31	4.69	5.1	4.93	4.83	4.7	4.58	4.54	4.57	4.52	4.48
	75	TC	47.4	47.4	47.4	47.4	47.4	47.4	47.4	47.4	46.4	44.1	41	39	37.8	37.4	37.3
		kW	2.76	2.91	3.11	3.34	3.61	3.95	4.28	4.65	4.91	4.94	4.75	4.62	4.58	4.56	4.51
	80	TC	41.1	41.1	41.1	41.1	41.1	41.1	41.1	41.1	41.1	41.1	41.1	40.1	38.6	38.1	38.0
		kW	2.37	2.51	2.65	2.84	3.06	3.25	3.55	3.88	4.15	4.4	4.62	4.69	4.71	4.67	4.61
1900	60	TC	77.3	77.3	77.3	77.3	72.7	68.3	64.2	60.4	56.7	53.4	50.2	47.7	45.8	44.4	42.5
		kW	4.25	4.59	5.03	5.48	5.31	5.16	5.05	4.95	4.86	4.77	4.69	4.6	4.58	4.54	4.5
	70	TC	58.0	58.0	58.0	58.0	58.0	58.0	58.0	52.6	49.5	46.4	43.4	42.0	41.0	40.2	40.0
		kW	3.18	3.41	3.66	3.95	4.34	4.72	5.13	4.96	4.85	4.72	4.59	4.55	4.57	4.51	4.47
	75	TC	58.1	58.1	58.1	58.1	58.1	58.1	58.1	58.1	57.0	54.1	50.4	47.8	46.4	45.9	45.7
		kW	3.23	3.41	3.64	3.91	4.23	4.62	5.01	5.45	5.75	5.79	5.57	5.41	5.37	5.35	5.28
	80	TC	41.9	41.9	41.9	41.9	41.9	41.9	41.9	41.9	41.9	41.9	41.9	40.8	39.3	38.9	38.8
		kW	2.39	2.52	2.67	2.86	3.08	3.27	3.58	3.91	4.18	4.43	4.66	4.73	4.75	4.71	4.64

Table 5

TC refers to total capacity S/T: refers to the ratio of sensible heat and total capacity kW: refers to total input power

5.3 BRB-36HWD1N1-M18 For Cooling

BRB-36HWD1N1-M18 For Cooling																		
Indoor Airflow (SCFM)	Outdoor DB	IWB (°F)	59				63				67				71			
		IDB (°F)	70	75	80	85	70	75	80	85	70	75	80	85	70	75	80	85
950	65	TC	29.7	30.0	30.6	31.0	30.6	31.0	31.3	31.6	32.7	33.0	33.3	33.5	/	39.8	40.1	40.4
		S/T	0.99	1.00	1.00	1.00	0.61	0.83	1.00	1.00	0.39	0.57	0.73	0.90	/	0.39	0.53	0.67
		kW	1.61	1.63	1.64	1.64	1.64	1.66	1.67	1.69	1.69	1.70	1.72	1.74	/	2.13	2.15	2.18
	75	TC	29.7	30.1	30.7	31.0	30.7	31.0	31.4	31.7	32.8	33.1	33.4	33.6	/	39.4	39.7	40.0
		S/T	1.00	1.00	0.99	1.00	0.62	0.83	1.00	1.00	0.39	0.56	0.73	0.90	/	0.39	0.53	0.67
		kW	1.78	1.80	1.83	1.83	1.83	1.85	1.87	1.88	1.87	1.90	1.92	1.94	/	2.35	2.37	2.39
	85	TC	29.3	29.6	30.2	30.6	30.2	30.6	30.9	31.2	32.3	32.6	32.9	33.1	/	38.7	39.0	39.2
		S/T	1.00	1.00	1.00	1.00	0.62	0.84	1.00	1.00	0.39	0.57	0.74	0.91	/	0.39	0.53	0.67
		kW	2.01	2.03	2.05	2.05	2.05	2.08	2.10	2.12	2.12	2.14	2.16	2.18	/	2.66	2.69	2.71
	95	TC	28.7	29.1	29.7	30.1	29.7	30.1	30.4	30.7	31.8	32.1	32.3	32.6	/	37.8	38.1	38.3
		S/T	1.00	1.00	1.00	1.00	0.62	0.84	1.00	1.00	0.39	0.57	0.74	0.92	/	0.39	0.53	0.68
		kW	2.42	2.44	2.47	2.47	2.47	2.49	2.52	2.54	2.56	2.58	2.60	2.63	/	3.17	3.19	3.22
105	TC	27.4	27.8	28.4	28.7	28.4	28.7	29.0	29.3	30.3	30.6	30.8	31.0	/	35.5	35.6	35.8	
	S/T	0.99	1.00	1.00	1.00	0.62	0.84	1.00	1.00	0.39	0.57	0.75	0.93	/	0.39	0.54	0.69	
	kW	2.90	2.93	2.96	2.96	2.96	2.99	3.02	3.06	3.06	3.09	3.11	3.14	/	3.70	3.71	3.72	
115	TC	22.9	23.1	23.7	23.9	23.7	23.9	24.1	24.4	25.4	25.6	25.7	25.9	/	27.5	27.7	27.8	
	S/T	1.00	1.00	1.00	1.00	0.62	0.85	1.00	1.00	0.40	0.60	0.79	0.99	/	0.39	0.58	0.76	
	kW	2.61	2.64	2.67	2.67	2.67	2.71	2.73	2.76	2.78	2.80	2.82	2.83	/	2.91	2.93	2.94	
1250	65	TC	31.9	32.2	33.0	33.3	33.0	33.3	33.7	34.0	35.3	35.5	35.8	36.1	/	42.6	42.9	43.2
		S/T	0.99	1.00	1.00	1.00	0.63	0.86	1.00	1.00	0.39	0.58	0.76	0.94	/	0.39	0.54	0.69
		kW	1.88	1.90	1.92	1.92	1.92	1.94	1.96	1.98	1.97	2.00	2.02	2.04	/	2.44	2.47	2.49
	75	TC	31.9	32.3	33.0	33.3	33.0	33.3	33.7	34.1	35.3	35.6	35.8	36.1	/	42.3	42.6	42.9
		S/T	1.00	1.00	1.00	1.00	0.62	0.85	1.00	1.00	0.39	0.58	0.76	0.94	/	0.39	0.54	0.69
		kW	2.05	2.08	2.10	2.10	2.10	2.12	2.14	2.16	2.16	2.18	2.21	2.23	/	2.57	2.60	2.62
	85	TC	31.4	31.7	32.4	32.8	32.4	32.8	33.1	33.5	34.7	35.0	35.2	35.5	/	41.2	41.5	41.8
		S/T	1.00	1.00	1.00	1.00	0.63	0.86	1.00	1.00	0.39	0.58	0.76	0.95	/	0.39	0.54	0.70
		kW	2.26	2.28	2.32	2.32	2.32	2.34	2.36	2.39	2.39	2.41	2.43	2.46	/	2.96	2.98	3.01
	95	TC	31.0	31.4	32.1	32.4	32.1	32.4	32.7	33.1	34.0	34.5	34.8	35.0	/	40.1	40.3	40.5
		S/T	1.00	1.00	0.99	1.00	0.63	0.87	1.00	1.00	0.39	0.58	0.76	1.00	/	0.39	0.55	0.71
		kW	2.69	2.72	2.75	2.75	2.75	2.77	2.81	2.84	2.85	2.87	2.90	2.92	/	3.48	3.51	3.54
105	TC	29.4	29.8	30.4	30.7	30.4	30.7	31.0	31.4	32.4	32.8	33.0	33.3	/	36.2	36.2	36.4	
	S/T	0.99	1.00	0.99	1.00	0.63	0.87	1.00	1.00	0.39	0.59	0.78	1.00	/	0.39	0.57	0.74	
	kW	3.20	3.23	3.27	3.27	3.27	3.31	3.34	3.37	3.38	3.41	3.44	3.47	/	3.75	3.77	3.79	
115	TC	22.7	22.9	23.4	23.7	23.4	23.7	23.9	24.2	25.8	25.9	25.5	25.6	/	26.6	26.7	26.8	
	S/T	1.00	1.00	1.00	1.00	0.64	0.88	1.00	1.00	0.40	0.62	0.86	1.00	/	0.40	0.62	0.84	
	kW	2.66	2.69	2.72	2.72	2.72	2.74	2.77	2.80	2.85	2.86	2.86	2.87	/	2.90	2.91	2.92	
1350	65	TC	33.9	34.3	35.0	35.4	35.0	35.4	35.8	36.2	37.5	37.8	38.0	38.3	/	44.9	45.2	45.9
		S/T	0.99	1.00	1.00	1.00	0.64	0.88	1.00	1.00	0.39	0.59	0.78	0.99	/	0.38	0.55	0.71
		kW	2.20	2.22	2.24	2.24	2.24	2.27	2.29	2.32	2.32	2.34	2.37	2.39	/	2.80	2.82	2.84
	75	TC	34.0	34.4	35.2	35.5	35.2	35.5	35.9	36.3	37.7	37.9	38.2	38.5	/	46.0	46.2	46.3
		S/T	0.99	1.00	1.00	1.00	0.63	0.88	1.00	1.00	0.39	0.59	0.78	1.00	/	0.38	0.55	0.71
		kW	2.26	2.28	2.32	2.32	2.32	2.34	2.36	2.39	2.39	2.41	2.43	2.46	/	3.08	3.09	3.09
	85	TC	33.3	33.7	34.4	34.8	34.4	34.8	35.1	35.5	36.9	37.1	37.4	37.6	/	43.4	43.6	43.9
		S/T	0.99	1.00	1.00	1.00	0.64	0.89	1.00	1.00	0.39	0.59	0.79	1.00	/	0.39	0.56	0.73
		kW	2.56	2.58	2.61	2.61	2.61	2.64	2.66	2.69	2.70	2.72	2.74	2.76	/	3.29	3.32	3.34
	95	TC	32.5	32.8	33.5	33.9	33.5	33.9	34.3	34.6	36.0	36.2	36.4	36.7	/	41.3	41.5	41.5
		S/T	1.00	1.00	1.00	1.00	0.64	0.90	1.00	1.00	0.39	0.60	0.80	1.00	/	0.39	0.57	0.75
		kW	3.00	3.04	3.07	3.07	3.07	3.10	3.13	3.16	3.18	3.20	3.22	3.24	/	3.71	3.72	3.72
105	TC	30.7	31.0	31.7	32.1	31.7	32.1	32.4	32.8	34.1	34.3	34.5	34.8	/	36.7	36.9	37.2	
	S/T	1.00	1.00	1.00	1.00	0.65	0.90	1.00	1.00	0.39	0.60	0.81	1.00	/	0.39	0.59	0.79	
	kW	3.53	3.56	3.60	3.60	3.60	3.64	3.68	3.72	3.74	3.77	3.79	3.82	/	3.93	3.95	3.99	
115	TC	22.9	23.0	23.6	23.9	23.6	23.9	24.1	24.3	25.4	25.5	25.6	25.8	/	27.2	27.3	27.4	
	S/T	1.00	1.00	1.00	1.00	0.66	1.00	1.00	1.00	0.40	0.66	0.93	1.00	/	0.40	0.65	0.90	
	kW	2.76	2.79	2.83	2.83	2.83	2.86	2.88	2.91	2.95	2.96	2.98	2.99	/	3.08	3.09	3.10	

Table 6

TC refers to total capacity S/T: refers to the ratio of sensible heat and total capacity kW: refers to total input power

5.4 BRB-36HWD1N1-M18 For Heating

BRB-36HWD1N1-M18 For Heating																	
Airflow (SCFM)	ID (°F)	OD (°F)	72	67	62	57	52	47	42	37	32	27	22	17	12	7	5
970	60	TC	42.4	42.4	42.3	42.3	42.2	40.7	36.1	32.7	30.1	28.9	26.3	22.8	21.7	20.3	19.2
		kW	2.36	2.52	2.74	2.97	3.21	3.23	3.07	2.94	2.85	3.11	3.00	2.86	2.77	2.70	2.62
	70	TC	32.8	32.6	32.8	32.7	32.4	32.3	31.2	30.6	29.6	28.4	25.6	22.4	21.2	20.0	19.0
		kW	1.77	1.86	2.05	2.19	2.35	2.56	2.78	3.00	3.12	3.38	3.24	3.09	2.99	2.91	2.82
	75	TC	27.6	27.5	27.5	27.5	27.5	27.5	26.2	25.7	25.4	24.4	23.6	21.3	20.1	18.7	17.3
		kW	1.47	1.58	1.71	1.84	2.01	2.18	2.29	2.48	2.65	2.88	3.07	3.22	3.12	3.03	2.94
	80	TC	22.7	22.7	22.7	22.7	22.6	22.6	21.7	21.3	21.1	20.0	19.4	17.5	17.8	18.1	17.1
		kW	1.22	1.30	1.41	1.53	1.64	1.78	1.88	2.07	2.19	2.31	2.46	2.61	2.82	3.07	3.06
1120	60	TC	47.4	47.4	47.3	46.0	43.4	41.2	36.7	33.2	30.7	29.4	26.4	23.3	22.1	20.7	19.6
		kW	2.79	2.96	3.19	3.28	3.19	3.16	3.03	2.90	2.84	3.09	2.97	2.85	2.77	2.70	2.63
	70	TC	36.7	36.5	36.2	36.2	36.2	36.0	34.7	32.4	30.1	28.7	26.0	23.0	21.6	20.2	19.2
		kW	2.04	2.18	2.31	2.50	2.72	2.88	3.21	3.17	3.08	3.34	3.22	3.07	2.99	2.91	2.83
	75	TC	30.9	30.8	30.6	30.8	30.7	30.3	29.3	28.8	28.5	27.3	25.7	21.6	20.4	19.0	17.5
		kW	1.71	1.82	1.94	2.13	2.25	2.43	2.63	2.84	3.04	3.31	3.36	3.20	3.11	3.02	2.94
	80	TC	25.3	25.3	25.3	25.3	25.3	25.2	24.4	23.6	23.4	22.3	21.7	19.7	20.0	18.7	17.3
		kW	1.41	1.49	1.62	1.74	1.87	2.01	2.19	2.30	2.46	2.65	2.83	2.98	3.22	3.15	3.05
1270	60	TC	52.8	51.9	49.0	46.9	44.2	41.9	37.2	33.7	31.2	29.9	27.0	23.6	22.4	21.1	20.0
		kW	3.28	3.36	3.28	3.26	3.18	3.16	3.03	2.93	2.86	3.11	3.01	2.89	2.83	2.75	2.69
	70	TC	40.6	40.4	40.4	40.4	40.3	40.3	36.4	32.9	30.6	29.2	26.5	23.2	22.0	20.7	19.6
		kW	2.34	2.49	2.71	2.92	3.15	3.40	3.31	3.18	3.11	3.36	3.24	3.10	3.03	2.96	2.88
	75	TC	34.6	34.4	34.4	34.0	34.0	33.9	32.9	32.1	30.2	28.8	26.1	22.0	20.8	19.3	18.0
		kW	1.99	2.11	2.30	2.40	2.60	2.82	3.05	3.28	3.24	3.51	3.38	3.23	3.15	3.07	2.99
	80	TC	28.4	28.3	28.3	28.3	28.3	28.2	26.9	26.4	26.2	25.0	24.2	21.7	20.5	19.1	17.7
		kW	1.66	1.75	1.90	2.01	2.19	2.35	2.47	2.66	2.83	3.06	3.24	3.37	3.27	3.19	3.10

Table 7

TC refers to total capacity S/T: refers to the ratio of sensible heat and total capacity kW: refers to total input power

6 Airflow Performance

Airflow performance data is based on cooling performance with a coil and no filter in place. Check the performance table for appropriate unit size selection.

External static pressure should stay within the minimum and maximum limits shown in the table below in order to ensure proper operation of both cooling, heating, and electric heating operation.

Model Number	Motor Speed		SCFM								
			External Static Pressure-Inches W.C. [kPa]								
			0[0]	0.1[.02]	0.2[.05]	0.3[.07]	0.4[.10]	0.5[.12]	0.6[.15]	0.7[.17]	0.8[.20]
60	Tap(1)	SCFM	1385	1300	1230	1136	1045	959	867	787	717
		Watts	164	171	180	192	204	217	232	238	249
	Tap(2)-Default Low Stage Setting	SCFM	1489	1432	1352	1279	1172	1088	1013	934	863
		Watts	1.76	1.8	1.89	1.96	2.02	2.13	2.24	2.34	2.43
	Tap(3)	SCFM	1843	1782	1711	1639	1572	1497	1409	1341	1271
		Watts	343	362	377	390	400	411	427	440	456
	Tap(4)-Default High Stage Setting	SCFM	1964	1903	1840	1786	1724	1655	1591	1488	1427
		Watts	435	450	466	479	494	507	521	535	551
	Tap(5)	SCFM	2339	2307	2247	2204	2135	2056	1922	1800	1659
		Watts	695	707	725	734	747	746	737	719	686
36	Tap(1)	SCFM	925	807	723	658	/	/	/	/	/
		Watts	114	120	126	130	/	/	/	/	/
	Tap(2)	SCFM	1103	993	911	841	776	710	596	/	/
		Watts	162	169	175	181	187	193	197	/	/
	Tap(3)	SCFM	1271	1185	1098	1031	968	819	767	709	648
		Watts	251	256	262	268	273	281	285	289	293
	Tap(4)	SCFM	1355	1310	1270	1180	1049	989	931	870	813
		Watts	296	301	307	312	318	323	327	331	336
	Tap(5)	SCFM	1522	1465	1364	1291	1231	1177	1121	1066	1017
		Watts	426	432	438	443	448	452	456	460	466

Table 8

 Bold outlined areas represent airflow outside of the required 300-450 cfm/ton range.

NOTES:

1. This table is only used to select the **highest blower speed**. The high stage airflow must be used as the rated airflow for the full load operation of machine.
2. The rated airflow of systems without electric heater kits requires between 300 and 450 cubic feet of air per minute (CFM). The rated airflow of systems with electric heater kits requires between 350 and 450 cubic feet of air per minute (CFM).
3. The air distribution system has the greatest effect on airflow. Therefore, the contractor should use only industry-recognized procedures.
4. Duct design and construction should be carefully done. System performance can be lowered dramatically through poor design or workmanship.
5. Air supplier ducts should be located along the perimeter of the conditioned space and properly sized. Improper location or insufficient air flow may cause drafts or noise in the ductwork.
6. Installers should balance the air distribution system to ensure proper quiet airflow to all rooms in the home. An air velocity meter or airflow hood can be used to balance and verify branch and system airflow (CFM).
7. For the IDP 3-ton, 4 Speed Fan default is Tap (1), Tap (2), Tap (3), Tap (4). For the IDP 5-ton, the default fan speeds are Tap (2) for low speed and Tap (4) for high speed.

 For instructions on how to select fan speeds, refer to the Installation Manual.

7 Sound Data

Mode	Frequency	3T dB (A)	5T dB (A)
Cooling	High	74	75
	Mid	73	74
	Low	61	66
Heating	High	74	75
	Mid	73	73
	Low	59	66
Fan	High	67	74
	Mid	62	70
	Low	55	64

Table 9 IDP Sound power level

8 Electrical Data

Size (Tons)	Voltage - Phase - Frequency	Compressors (each)		OD Fan Motors (each)	Supply Blower Motor	Unit Circuit	
		RLA	LRA	FLA	FLA	MCA ¹ (Amps)	Max Fuse ² / Breaker ³ Size (Amps)
60 (5.0)	208/230-1-60	27A	52A	2.1A	6.0A	41.9	60
36 (3.0)	208/230-1-60	19A	52A	1.4A	3.5A	28.7	45

Table 10 Electrical Data Without Electric Heat

Heat Kit Model	Heat Pump Model	(kW) 208/240V	Stages	FLA (Amps) 208/240V	Dual Point		Single Point	
					MCA ¹ (Amps) 208/240V	Max Fuse ² / Breaker ³ Size (Amps)* 208/240V	MCA ¹ (Amps) 208/240V	Max Fuse ² / Breaker ³ Size (Amps)** 208/240V
EHK-05J	60	3.8/5	1	18.1/20.8	23/26	25/30	65/68	80/80
EHK-08J		5.6/7.5	1	27.1/31.3	34/40	35/40	76/81	90/100
EHK-10J		7.5/10.0	1	36.1/41.7	46/53	50/60	87/94	100/110
EHK-15J		11.3/15	2	54.2/62.5	68/79	70/80	110/120	110/125
EHK-20J		15/20	2	72.2/83.3	91/105	100/110	133/146	150/150
EHK-05J	36	3.8/5	1	18.1/20.8	23/26	25/30	52/55	60/60
EHK-08J		5.6/7.5	1	27.1/31.3	34/40	35/40	63/68	70/70
EHK-10J		7.5/10.0	1	36.1/41.7	46/53	50/60	74/81	80/90
EHK-15J		11.3/15	2	54.2/62.5	68/79	70/80	97/107	100/110

Table 11 Electrical Data With Electric Heat

1 Minimum Circuit Ampacity.

2 Maximum Over Current Protection per Standard UL 1995.

3 Fuse or HACR circuit breaker size field installed.

* Max Fuse/Breaker Sizes are for electric heater ONLY (dual point electric heat). DOES NOT include breaker size for the unit.

** Max Fuse/Breaker Sizes include breaker size for the unit AND electric heat (single point electric heat).



Refer to Electric Heat Kit Installation Manual, some heater kits include fuses from the manufacturer.

9 Dimensions

9.1 BRB-60HWD1N1-M19 Unit Dimensions

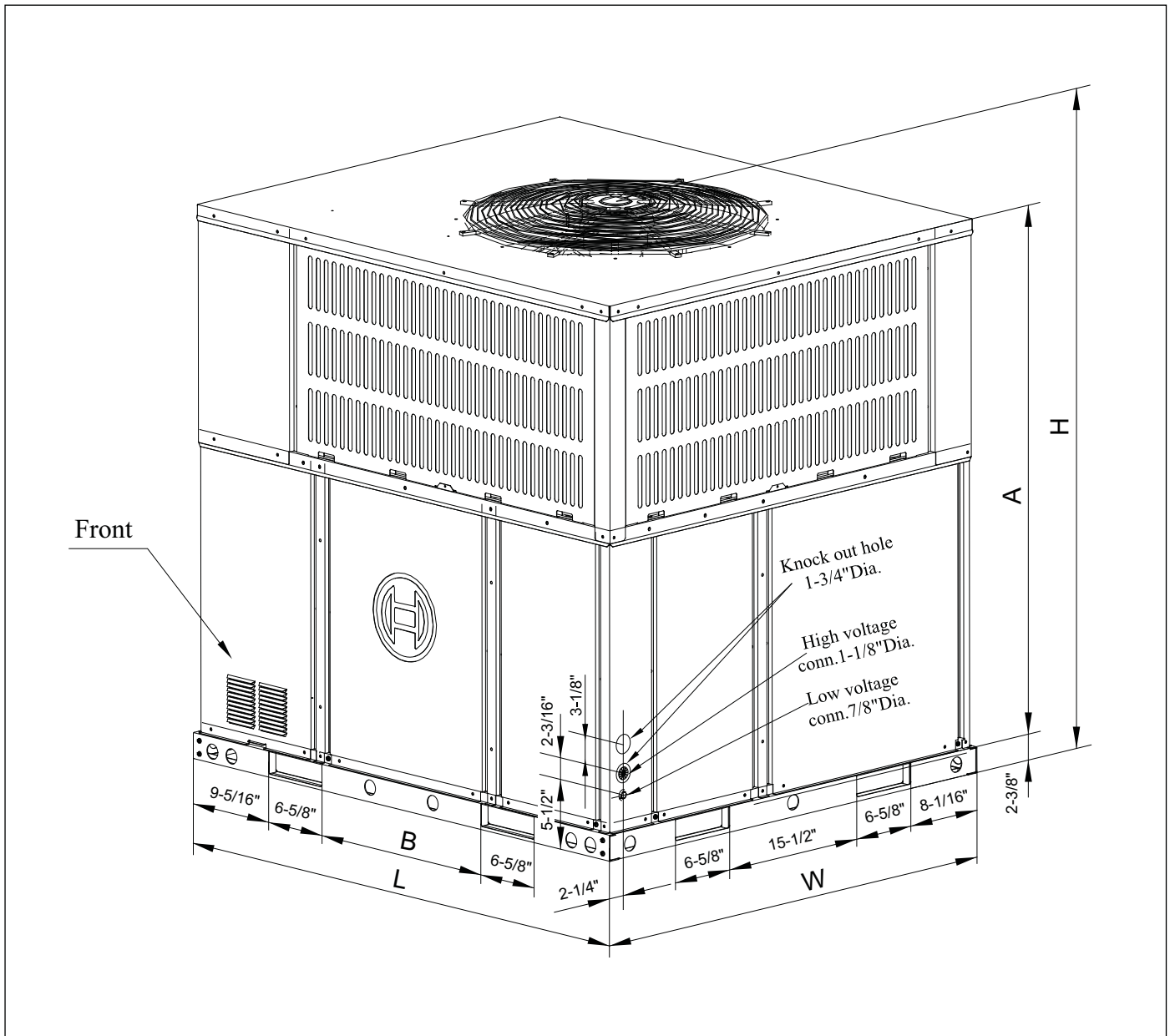

Figure 2

Heat Pump Model	L	W	H	A	B
BRB-60HWD1N1-M19	51-9/16"	44-13/16"	51-7/16"	47-5/16"	19-11/16"

Table 12 Unit Dimensions

Heat Pump Model	Net Weight	Gross Weight
BRB-60HWD1N1-M19	561 lbs (255kg)	596 lbs (271kg)

Table 13 Unit Weights

9.2 BRB-60HWD1N1-M19 Dimensions - Back and Bottom

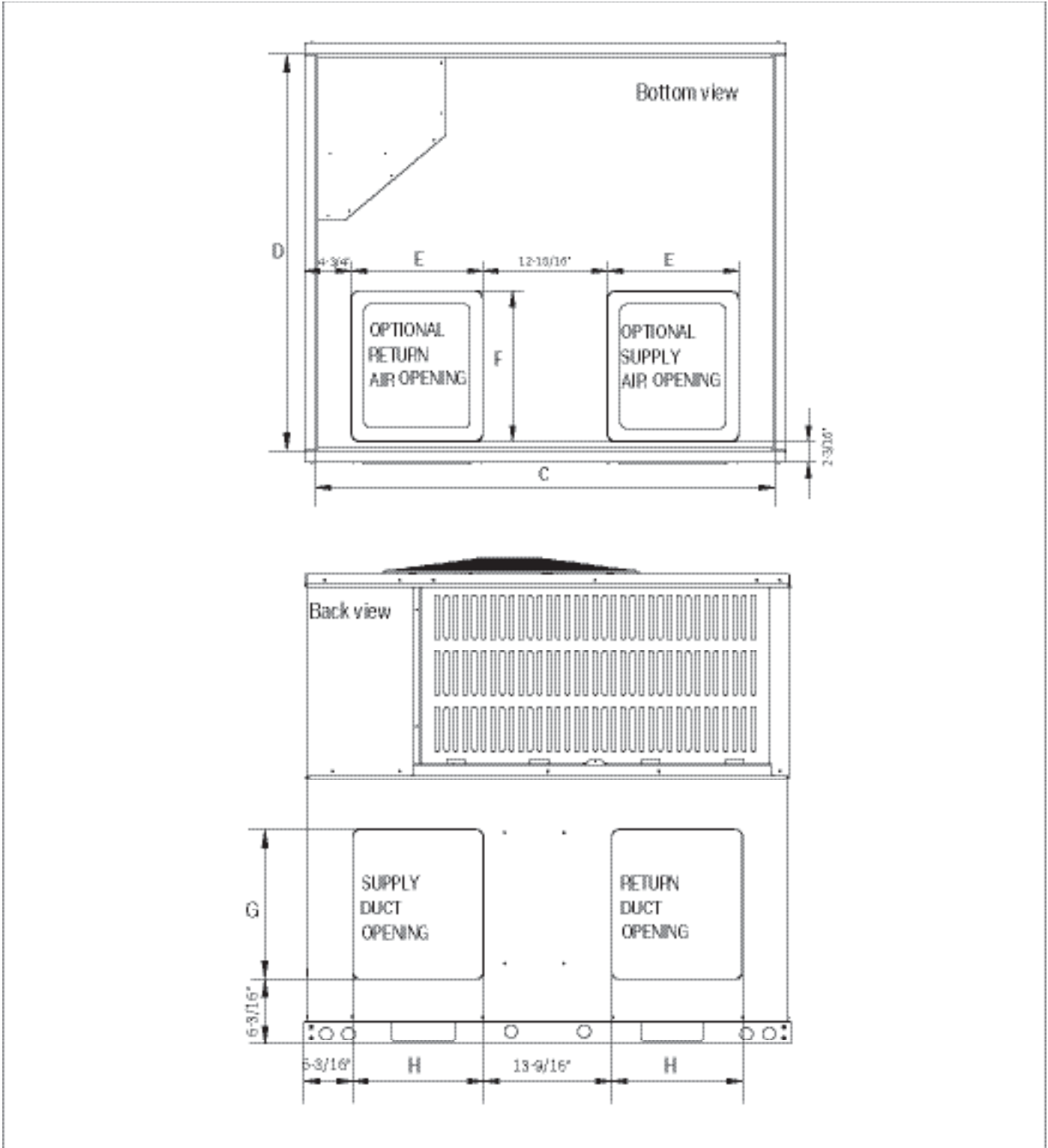

Figure 3

Heat Pump Model	C	D	E	F	G	H
BRB-60HWD1N1-M19	49-1/4"	42-1/2"	14-1/8"	16-1/8"	15-7/8"	13-7/8"

Table 14 Dimensions - Back and Bottom

9.3 BRB-60HWD1N1-M19 Dimensions - Right and Top

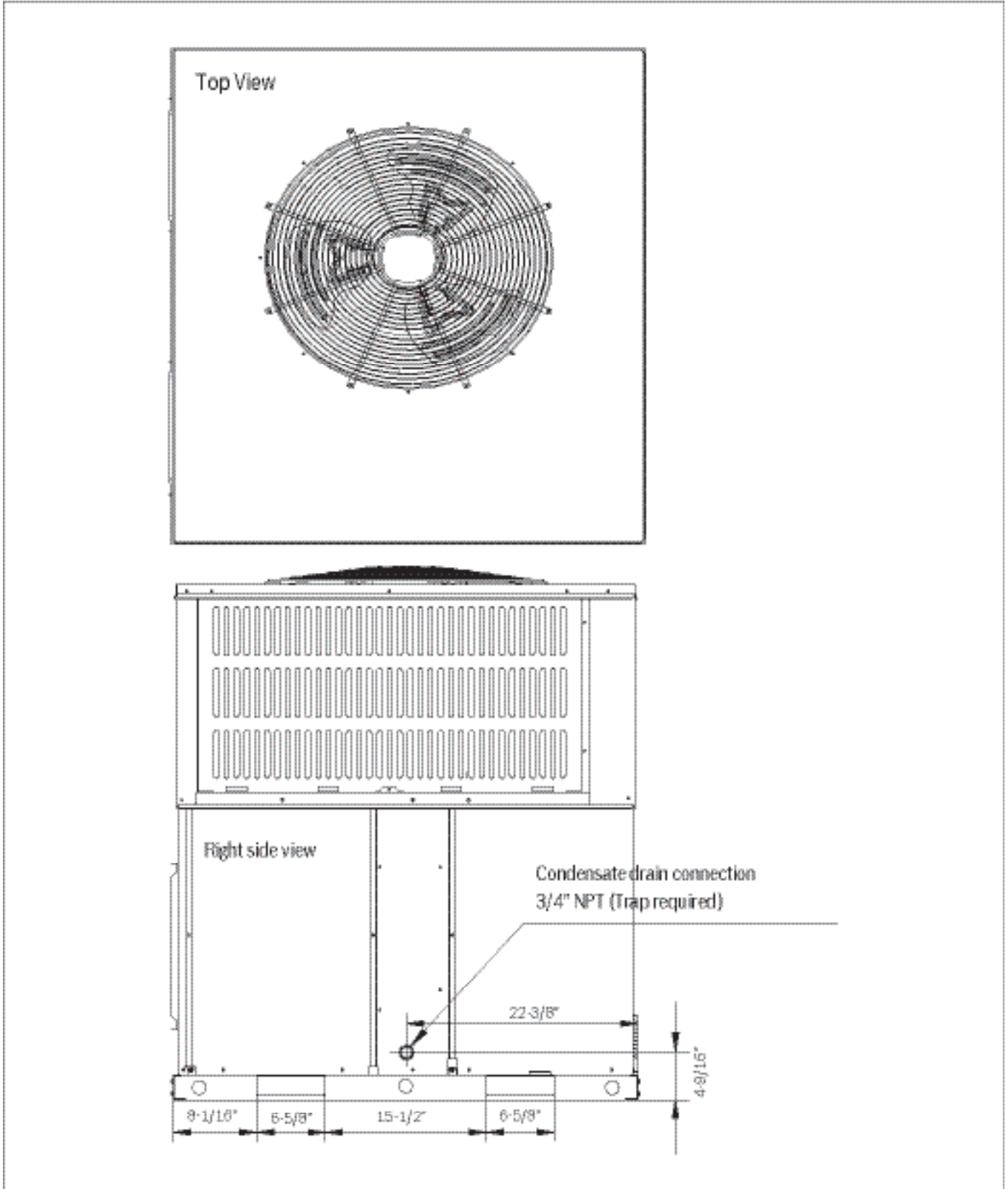

Figure 4

9.4 BRB-36HWD1N1-M18 Unit Dimensions

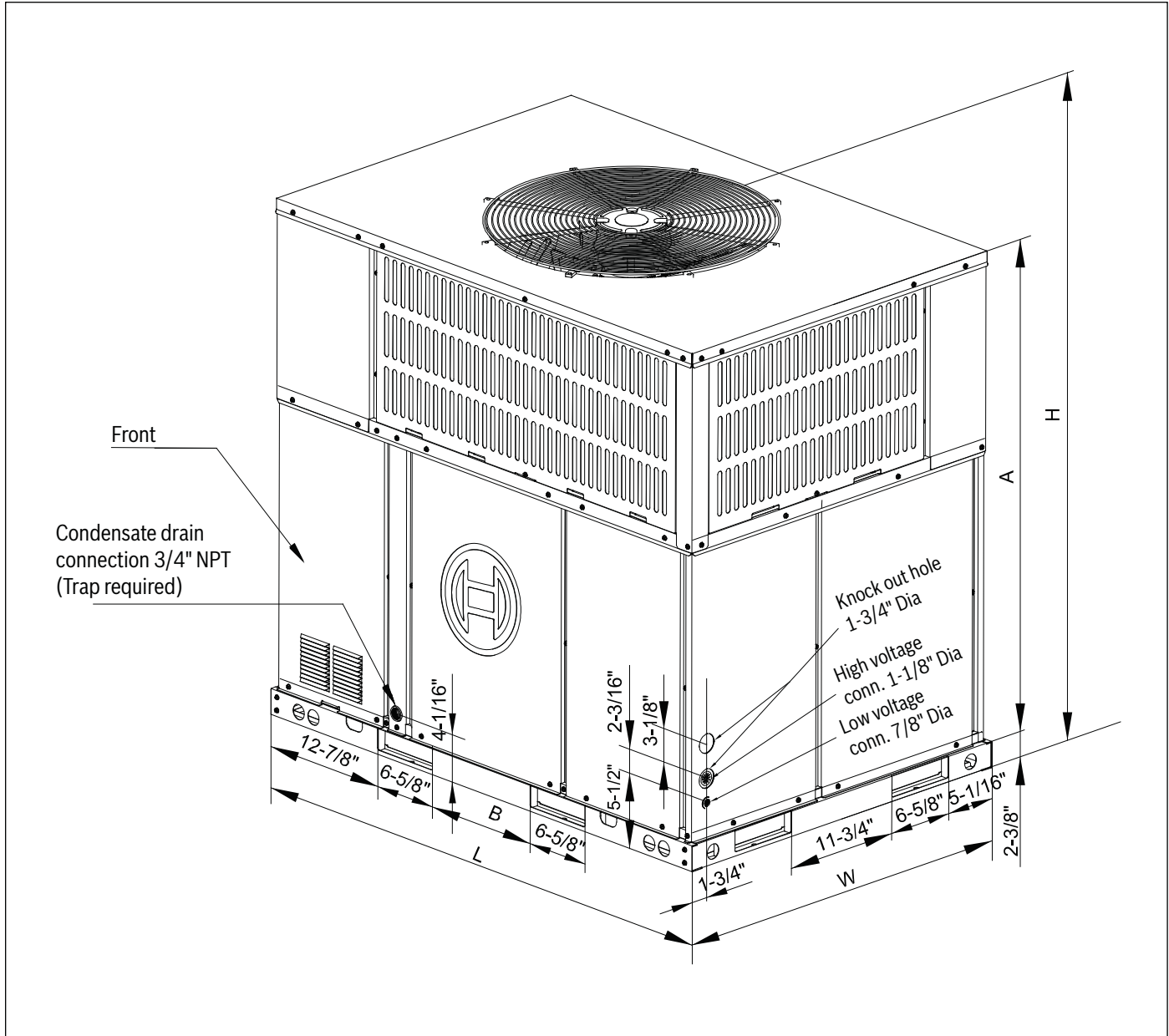

Figure 5

Heat Pump Model	L	W	H	A	B
BRB-36HWD1N1-M18	50-11/16"	35-1/16"	46-13/16"	44-1/16"	11-3/4"

Table 15 Unit Dimensions

Heat Pump Model	Net Weight	Gross Weight
BRB-36HWD1N1-M18	412 lbs (187 kg)	432 lbs (196 kg)

Table 16 Unit Weights

9.5 BRB-36HWD1N1-M18 Dimensions - Back and Bottom

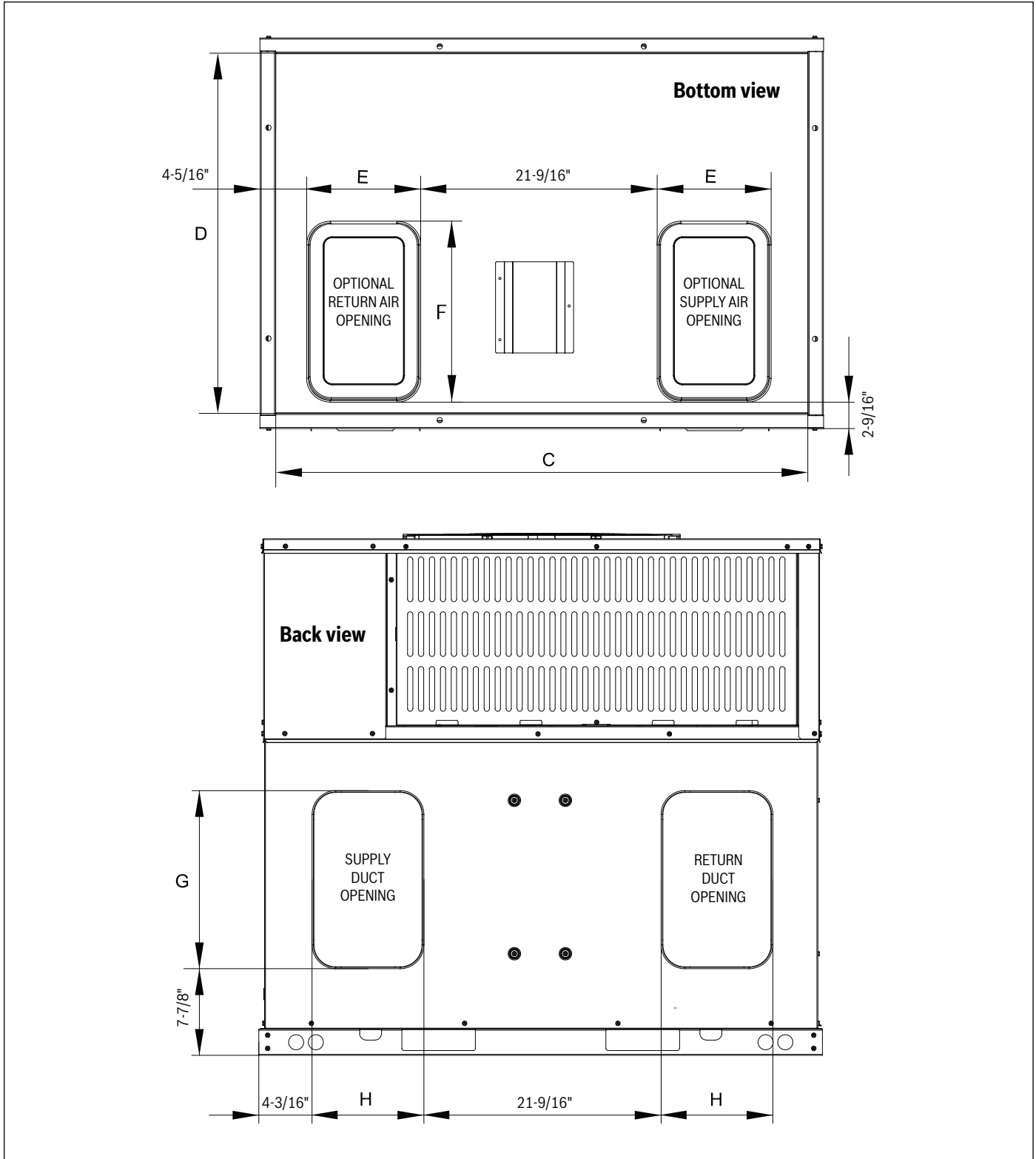

Figure 6

Heat Pump Model	C	D	E	F	G	H
BRB-36HWD1N1-M18	47-13/16"	32-1/4"	9-15/16"	15-7/8"	15-3/4"	9-3/4"

Table 17 Dimensions - Back and Bottom

9.6 BRB-36HWD1N1-M18 Dimensions - Right and Top

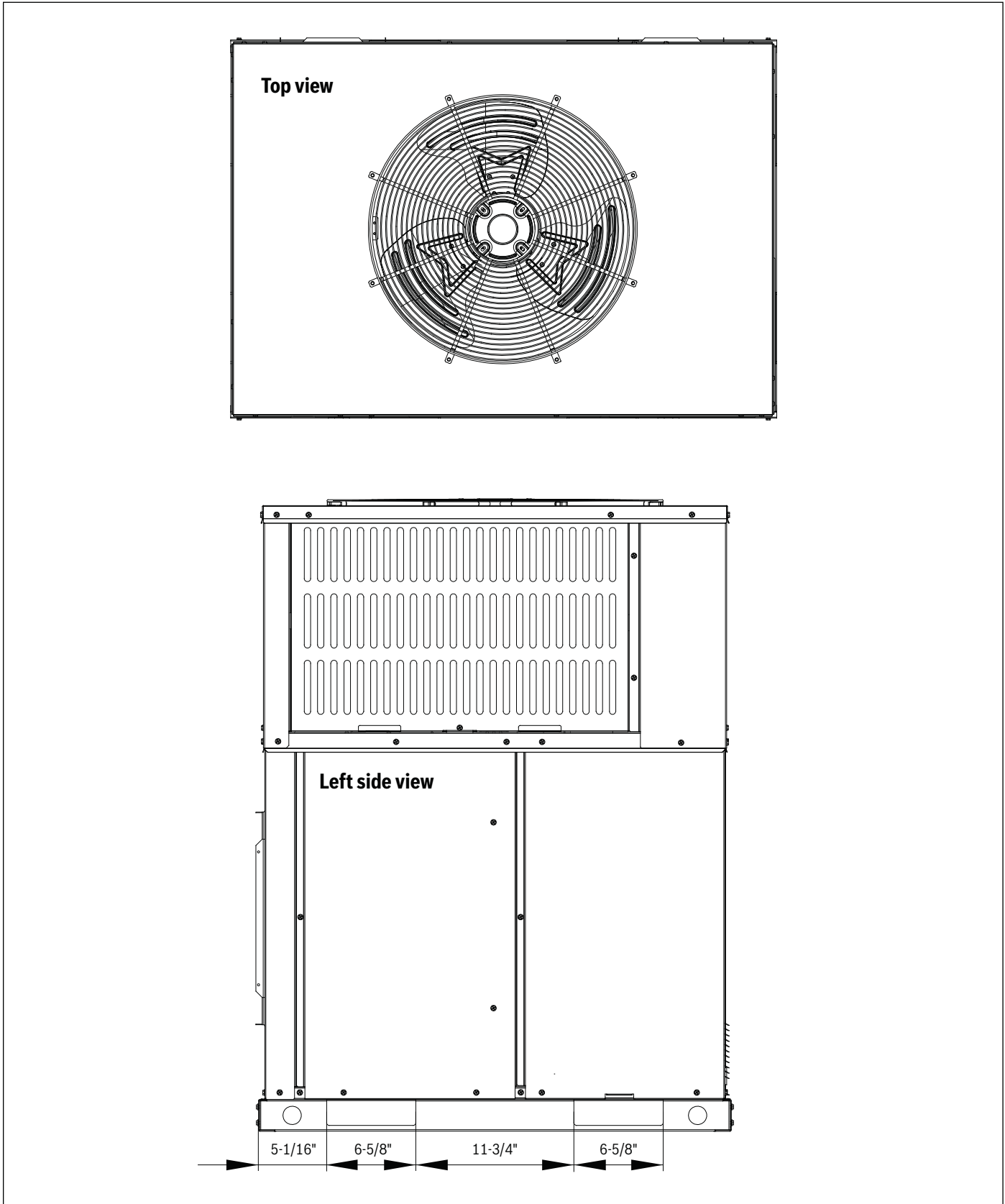

Figure 7

10 Rooftop Installation - Curb Mounting

The manufacturer does not supply roof curbs, they must be field supplied. Refer to Figure 11 for recommended roof curb dimensions. On applications when a roof curb is used, the unit must be positioned on the curb so the front of the unit is tight against the curb.

The default orientation from the factory is for horizontal airflow. Convert the unit to downflow using the following procedure:

1. Remove sheet metal screws from both the supply air and return air panels.
2. Add foam tape on the perimeter of the non painted side of each panel.
3. Move and re-secure the panels to the downflow location using the sheet metal screws from step 1.

For more information, refer to the the Conversion Kit Manual included with each heat pump unit.

Install the field-supplied roof mounting curb according to the Installation Instructions supplied with the curb. Install insulation, cant strips, roofing, and flashing. Ductwork must be attached to curb.

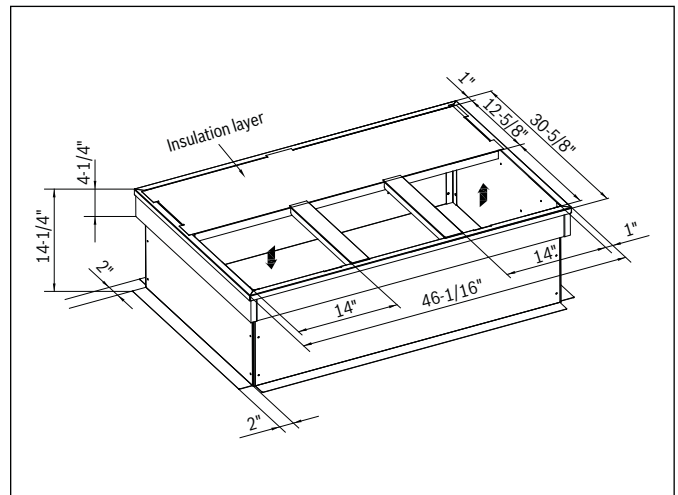

Figure 8 3T Roof Curb Dimensions

NOTICE:

- ▶ The gasketing of the unit to the roof curb is critical for a water tight seal. Install gasketing material supplied with the field supplied roof curb. Improperly applied gasketing also can result in air leaks and poor unit performance.



CAUTION:

- ▶ The unit must be secured to the curb by installing screws through the bottom of the curb flange and into the unit base rails.

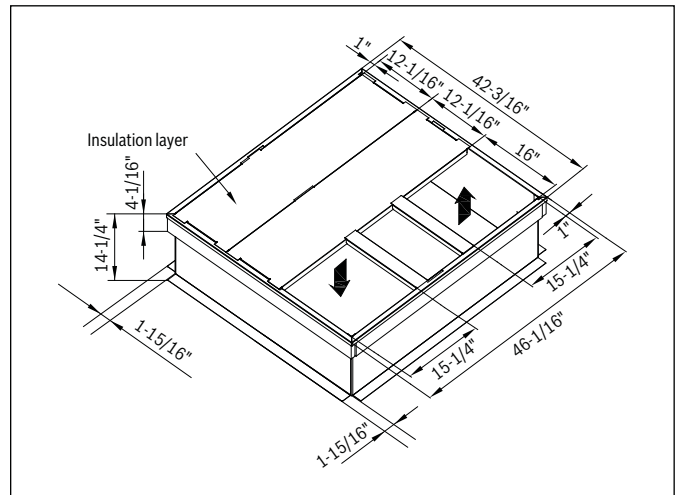

Figure 9 5T Roof Curb Dimensions



For units applied with a roof curb, the minimum clearance may be reduced from 1 inch to 1/2 inch between combustible roof curb material and supply air duct.

NOTICE: UNIT/STRUCTURAL DAMAGE HAZARD

- ▶ Failure to follow this caution may result in property damage. Ensure there is sufficient clearance for saw blade when cutting the outer horizontal flange of the roof curb so there is no damage to the roof or flashing.

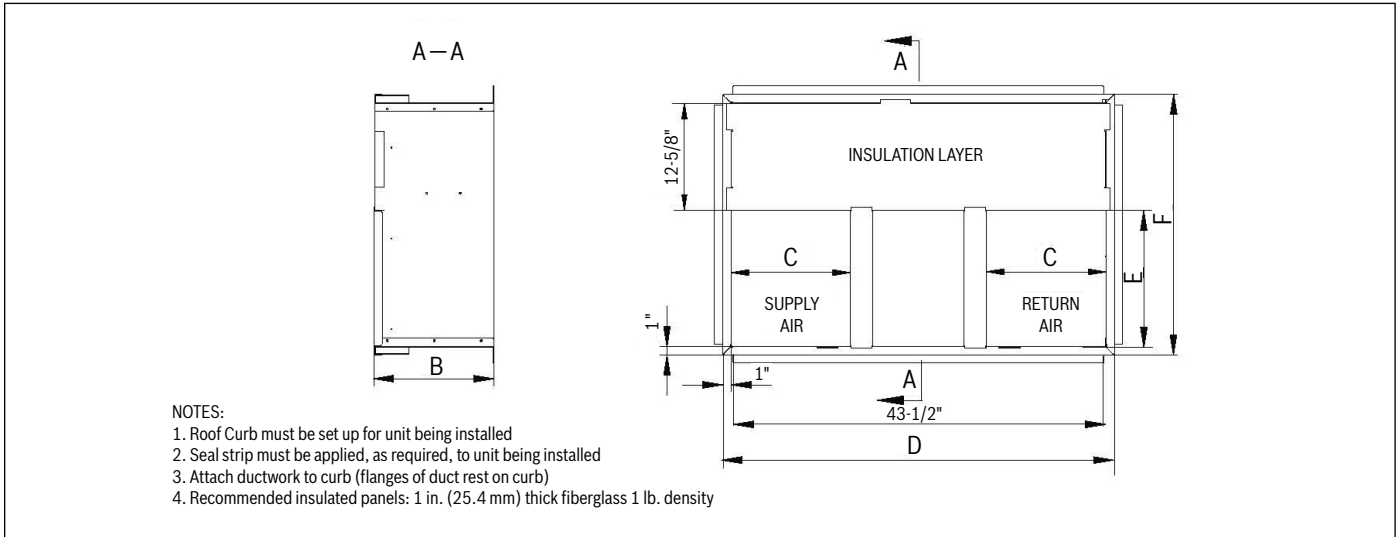

Figure 10 3T Roof Curb Details

	B	C	D	E	F
CURB	14-1/4"	14"	46-1/16"	16"	30-5/8"

Table 18 3T Roof Curb Details - inches

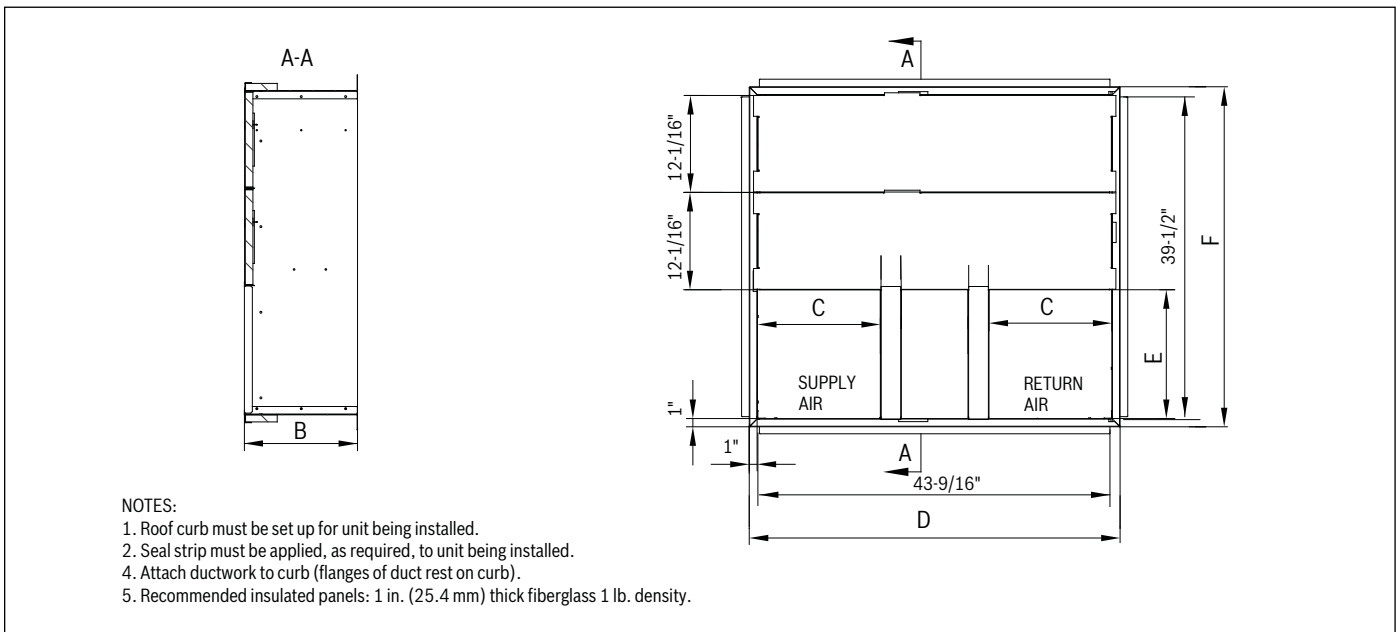

Figure 11 5T Roof Curb Details

	B	C	D	E	F
CURB	14-1/4"	15-1/4"	46-1/16"	16"	42-3/16"

Table 19 5T Roof Curb Details - inches

11 Wiring Diagram

11.1 BRB-60HWD1N1-M19 Wiring Diagram

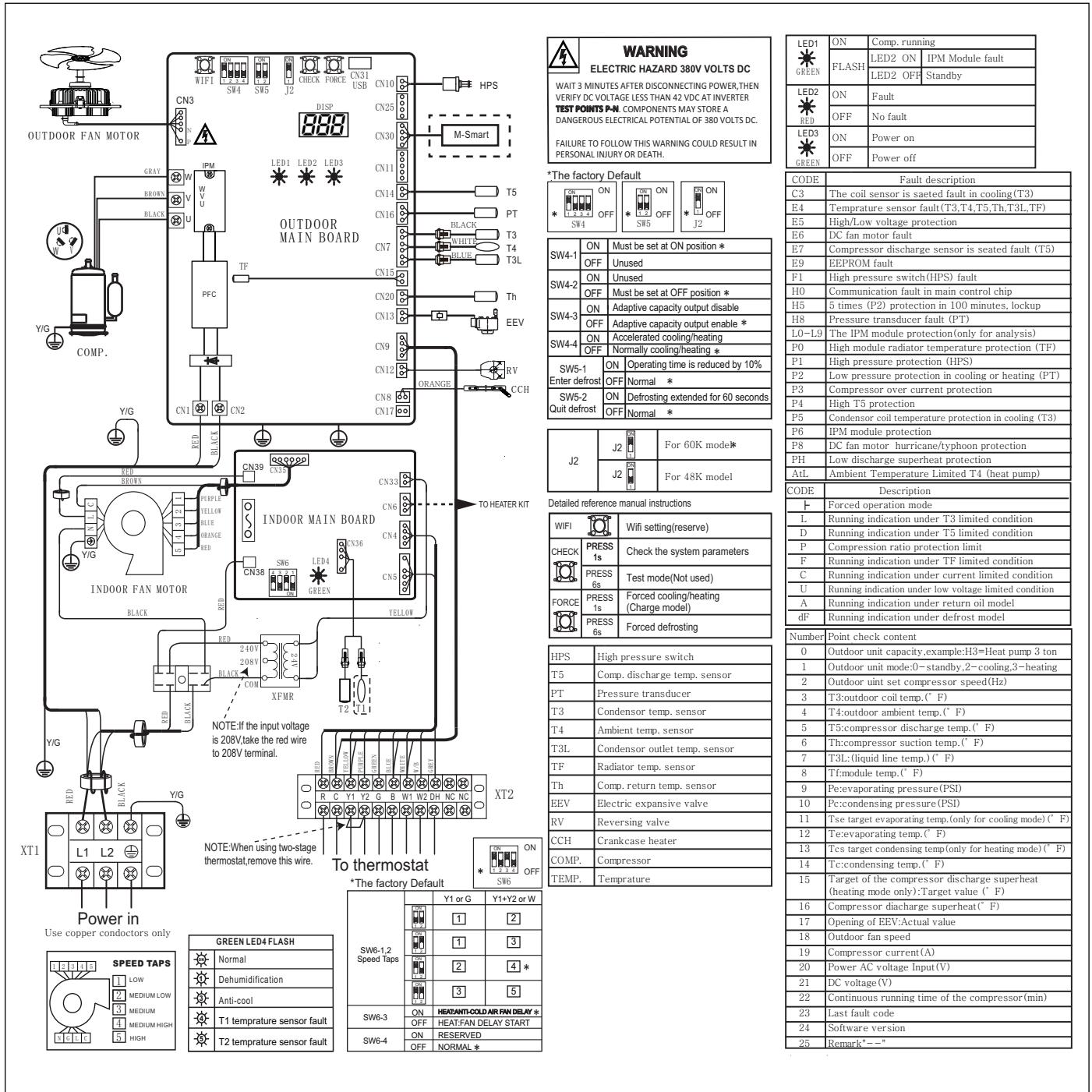

Figure 12

11.2 BRB-36HWD1N1-M18 Wiring Diagram

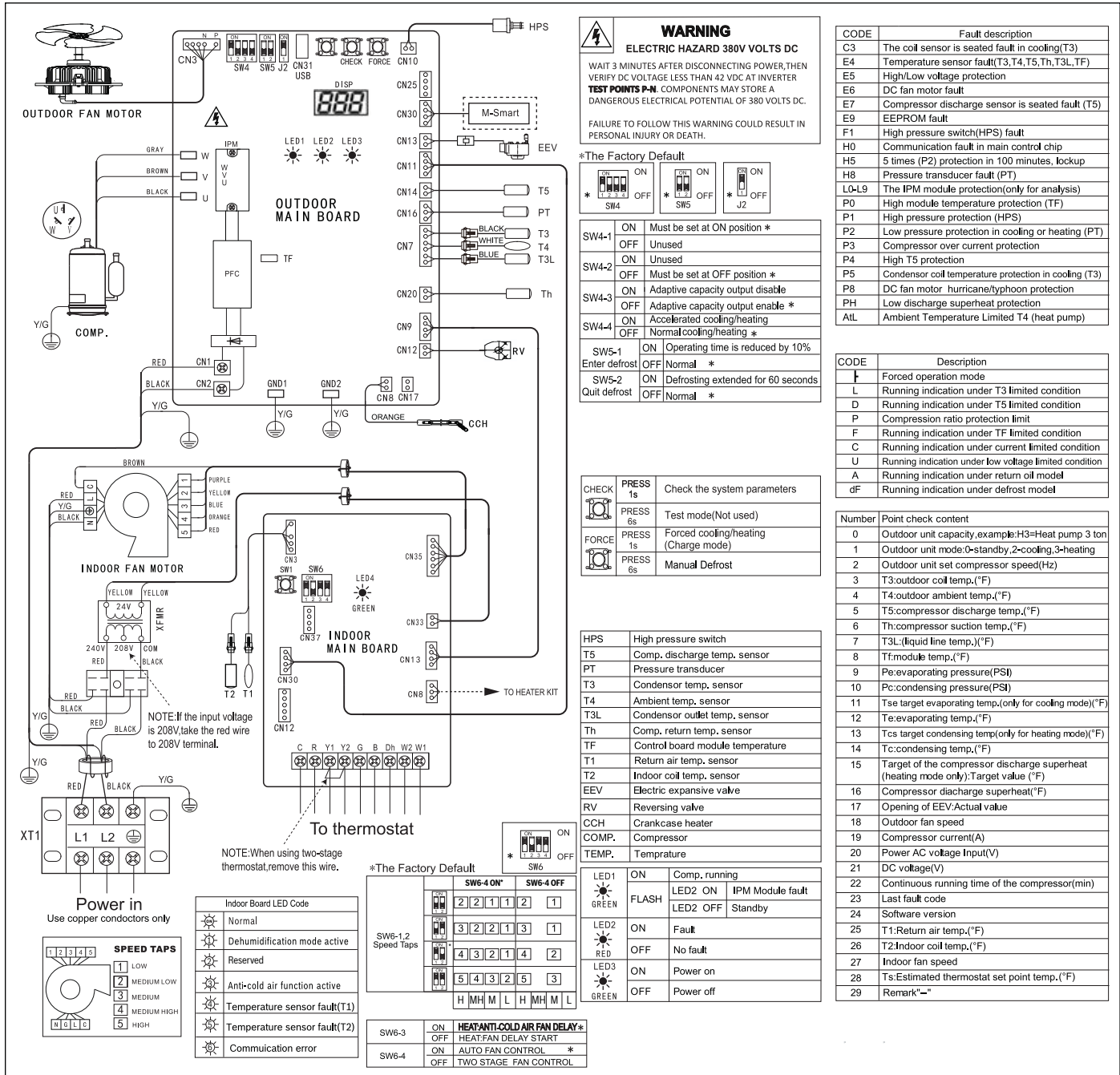

Figure 13

United States and Canada

Bosch Thermotechnology Corp.
65 Grove St.
Watertown, MA 02472

Tel: 866-642-3198
Fax: 603-965-7581
www.boschheatingandcooling.com