

# Bosch BVA Series Air Handler

2-3-4-5 Ton Capacity

R410A



**BOSCH**

## Installation Instructions





---

**Table of Contents**

---

<b>1</b>	<b>Key to symbols and safety instructions</b>	<b>4</b>
<b>2</b>	<b>General</b>	<b>6</b>
<b>3</b>	<b>Applications</b>	<b>8</b>
<b>4</b>	<b>Electrical wiring</b>	<b>10</b>
<b>5</b>	<b>Airflow performance</b>	<b>12</b>
<b>6</b>	<b>Ductwork</b>	<b>13</b>
<b>7</b>	<b>Refrigerant connections</b>	<b>14</b>
<b>8</b>	<b>Air filter (not factory-installed)</b>	<b>14</b>
<b>9</b>	<b>Filter installation dimensions</b>	<b>15</b>
<b>10</b>	<b>Wiring diagram</b>	<b>16</b>
<b>11</b>	<b>Spare parts</b>	<b>19</b>

---

## 1 Key to symbols and safety instructions

### 1.1 Key to symbols

#### Warnings



Warnings in this document are identified by a warning triangle printed against a grey background. Keywords at the start of a warning indicate the type and seriousness of the ensuing risk if measures to prevent the risk are not taken.

The following keywords are defined and can be used in this document:

- ▶ **DANGER** indicates a hazardous situation which, if not avoided, will result in death or serious injury.
- ▶ **WARNING** indicates a hazardous situation which, if not avoided, could result in death or serious injury.
- ▶ **CAUTION** indicates a hazardous situation which, if not avoided, could result in minor to moderate injury.
- ▶ **NOTICE** is used to address practices not related to personal injury.

#### Important information



This symbol indicates important information where there is no risk to people or property.

### 1.2 Safety

#### Please read before proceeding



#### **DANGER:**

- ▶ These instructions are intended as an aid to qualified licensed service personnel for proper installation, adjustment and operation of this unit. Read these instructions thoroughly before attempting installation or operation. Failure to follow these instruction may result in improper installation, adjustment, service or maintenance possibly resulting in fire, electrical shock, property damage, personal injury or death.



This document is customer property and is to remain with this unit. These instructions do not cover all the different variations of systems nor does it provide for every possible contingency to be met in connection with installation.



#### **CAUTION:**

- ▶ All phases of this installation must comply with NATIONAL, STATE AND LOCAL CODES. If additional information is required please contact your local distributor..



#### **WARNING: HAZARDOUS VOLTAGE**

- ▶ Disconnect all power to unit before installing or servicing. More than one disconnect switch may be required to deenergize the equipment. Hazardous voltage can cause severe personal injury or death.



#### **WARNING:**

- ▶ If removal of the blower assembly is required, all disconnect switches supplying power to the equipment must be deenergized and locked (if not in sight of unit ) so the field power wires can be safely removed from the blower assembly. Failure to do so can cause electrical shock resulting in personal injury or death.



#### **WARNING:**

- ▶ Because of possible damage to equipment or personal injury, installation, service, and maintenance should be performed by a trained, qualified service personnel. Consumer service is recommended only for filter cleaning / replacement. Never operate the unit with the access panels removed.

**WARNING:**

- ▶ These instructions are intended as an aid to qualified, licensed service personnel for proper installation, adjustment and operation of this unit. Read these instructions thoroughly before attempting installation or operation. Failure to follow these instructions may result in improper installation, adjustment, service or maintenance, possibly resulting in fire, electrical shock, property damage, personal injury or death.

**WARNING: PROPOSITION 65:**

- ▶ This appliance contains fiberglass insulation. Respirable particles of fiberglass are known to State of California to cause cancer.
- ▶ All manufacturer products meet current federal OSHA Guidelines for safety. California Proposition 65 warnings are required for certain products, which are not covered by the OSHA standards.
- ▶ California's Proposition 65 requires warnings for products sold in California that contain or produce any of over 600 listed chemicals known to the State of California to cause cancer or birth defects such as fiberglass insulation, lead in brass, and combustion products from natural gas.
- ▶ All "new equipment" shipped for sale in California will have labels stating that the product contains and /or produces Proposition 65 chemicals. Although we have not changed our processes, having the same label on all our products facilitates manufacturing and shipping. We cannot always know "when, or if" products will be sold in the California market.
- ▶ You may receive inquiries from customers about chemicals found in, or produced by, some of our heating and airconditioning equipment, or found in natural gas used with some of our products. Listed below are those chemicals and substances commonly associated with similar equipment in our industry and other manufacturers.
  - Glass Wool (Fiberglass) Insulation
  - Carbon Monoxide (CO).
  - Formaldehyde
  - Benzene
- ▶ More details are available at the websites for OSHA (Occupational Safety and Health Administration), at [www.osha.gov](http://www.osha.gov) and the State of California's OEHHA (Office of Environmental Health Hazard Assessment), at [www.oehha.org](http://www.oehha.org). Consumer education is important since the chemicals and substances on the list are found in our daily lives. Most consumers are aware that products present safety and health risks, when improperly used, handled and maintained.

**WARNING:**

- ▶ The unit must be permanently grounded. Failure to do so can result in electrical shock causing personal injury or death.

**WARNING:**

- ▶ The first 6 inches of supply air plenum and ductwork must be constructed of sheet metal as required by NFPA 90B. The supply air plenum or duct must have a solid sheet metal bottom piece directly after the air handler unit with no openings, registers or flexible air ducts located in it. If flexible supply air ducts are used they may be located only in the side walls of the rectangular plenum, a minimum of 6 inches from the solid bottom. Metal plenum of duct may be connected to the non-combustible floor base for downflow. Exposing combustible non-metal. material to the supply opening of a downflow unit can cause a fire resulting in property damage, personal injury or death.

**CAUTION:**

- ▶ Make sure the blower motor support is tight (3-motor mounting bolts - Fig. 1). Then check to see if wheel is tightly secured to motor shaft before operation unit.

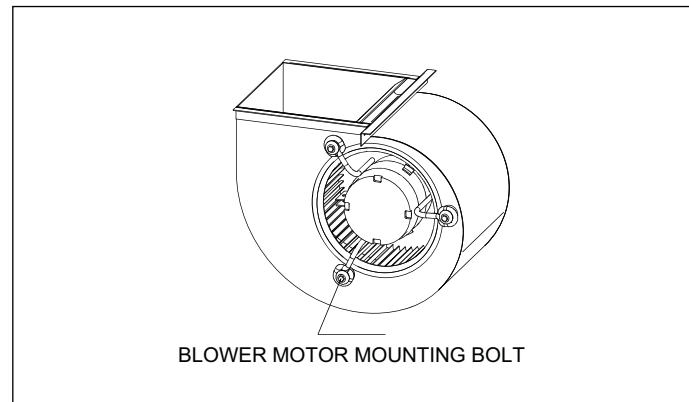

Figure 1

## 2 General

The unit can be positioned for bottom air return in the upflow position, left and right return in the horizontal position, top return in downflow position.

This Air Handler provides the flexibility for installation in any upflow, downflow or horizontal application. Adjust motor speed tap through DIP switch to select correct air flow according to blower performance table.

Top and side power and control wiring, accessible screw terminals for control wiring all combine to make the installation easy, and minimize installation cost. See fig.3.

To ensure the proper installation, select a solid and level site. Ensure enough space is maintained for installation and maintenance.

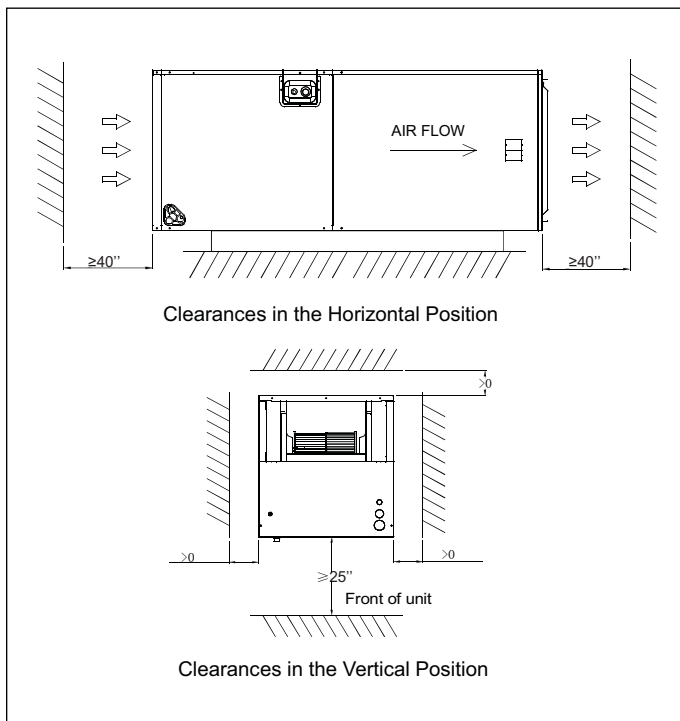

Figure 2

2.1 Unit dimensions

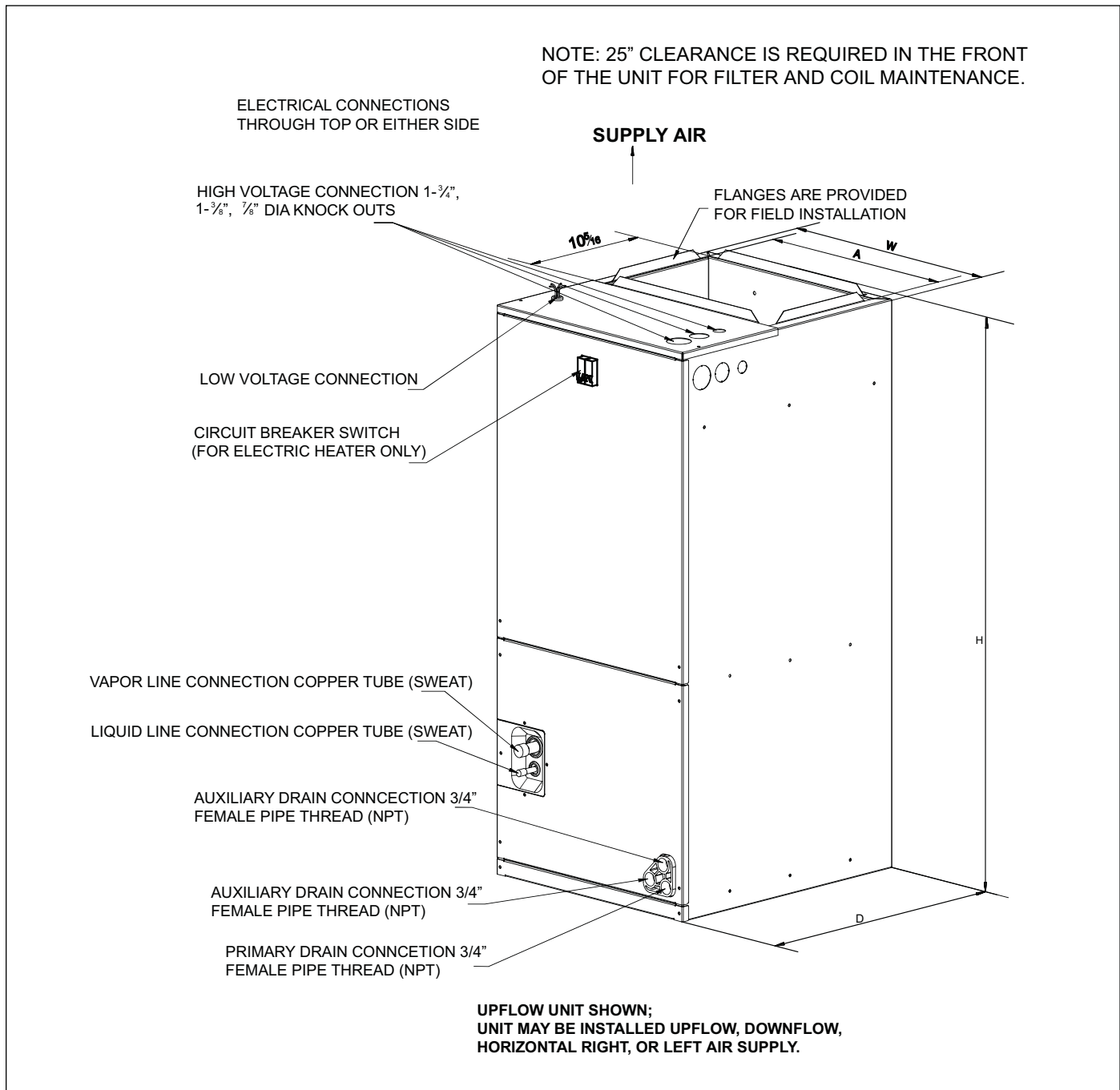

Figure 3

Model Size	Dimensions Inch [mm]				
	Unit Height "H" In. [mm]	Unit Width "W" In. [mm]	Unit Length "D" In. [mm]	Supply Duct "A"	Liquid Line / Vapor Line
24	46-1/2"[1180]	19-5/8"[500]	21-5/8"[550]	18"[456]	3/8" / 3/4" [9.5]/[19]
36	46-1/2"[1180]	19-5/8"[500]	21-5/8"[550]	18"[456]	3/8" / 3/4" [9.5]/[19]
48	54-1/2"[1385]	22"[560]	24"[610]	19-1/2"[496]	3/8" / 7/8" [9.5]/[22]
60	54-1/2"[1385]	22"[560]	24"[610]	19-1/2"[496]	3/8" / 7/8" [9.5]/[22]

Table 1

### 3 Applications

#### 3.1 Vertical upflow

- ▶ Vertical Upflow configuration is the factory default on all models (see Fig 3).
- ▶ If return air is to be ducted, install duct flush with floor. Use fireproof resilient gasket 1/8 to 1/4 in. thick between the ducts, unit and floor. Set unit on floor over opening.



Lightly tighten the drain connections so they do not leak. Using excessive force may/will cause damage to the unit. (see Fig.3&4)

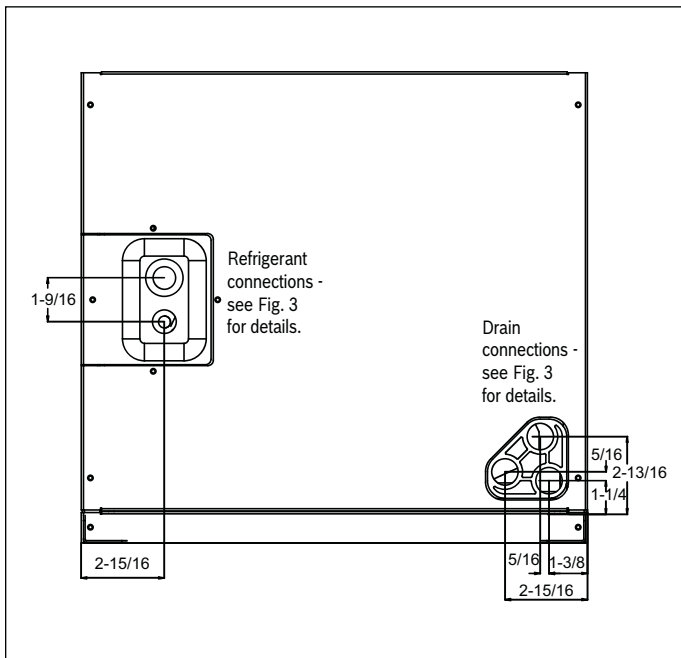

Figure 4 Dimensions for front connect coil

#### 3.2 Vertical downflow

##### Conversion to Vertical Downflow:

A vertical upflow unit may be converted to vertical downflow. Remove the door and indoor coil and reinstall 180° from original position. See Fig 5.



To comply with Safety Standards and the National Electric Code for downflow application, the circuit breaker(s) on field installed electric heater kits refer to electric heater kit installation manual for more detail. The breaker switch “on” position and marking are up and, “off” position and marking are down.



##### CAUTION:

- ▶ When using the unit with electric heater kits, the switch on the front of panel is used for these heaters only.

#### 3.3 Horizontal

Horizontal right is the default factory configuration for the units. Conversion to Horizontal left: A vertical upflow unit may be converted to horizontal left by removing indoor coil assembly and reinstalling coil as shown for left hand air supply.

- ▶ Rotate the unit 90° into the horizontal left position, with the coil compartment on the right and the blower compartment on the left. See Fig. 5.
- ▶ Reinstall the indoor coil 180° from original position. Ensure the retaining channel is fully engaged with the coil rail. See Fig. 5.
- ▶ Secondary drain pan kits are recommended when the unit is configured for the horizontal position over a finished ceiling and/or living space.

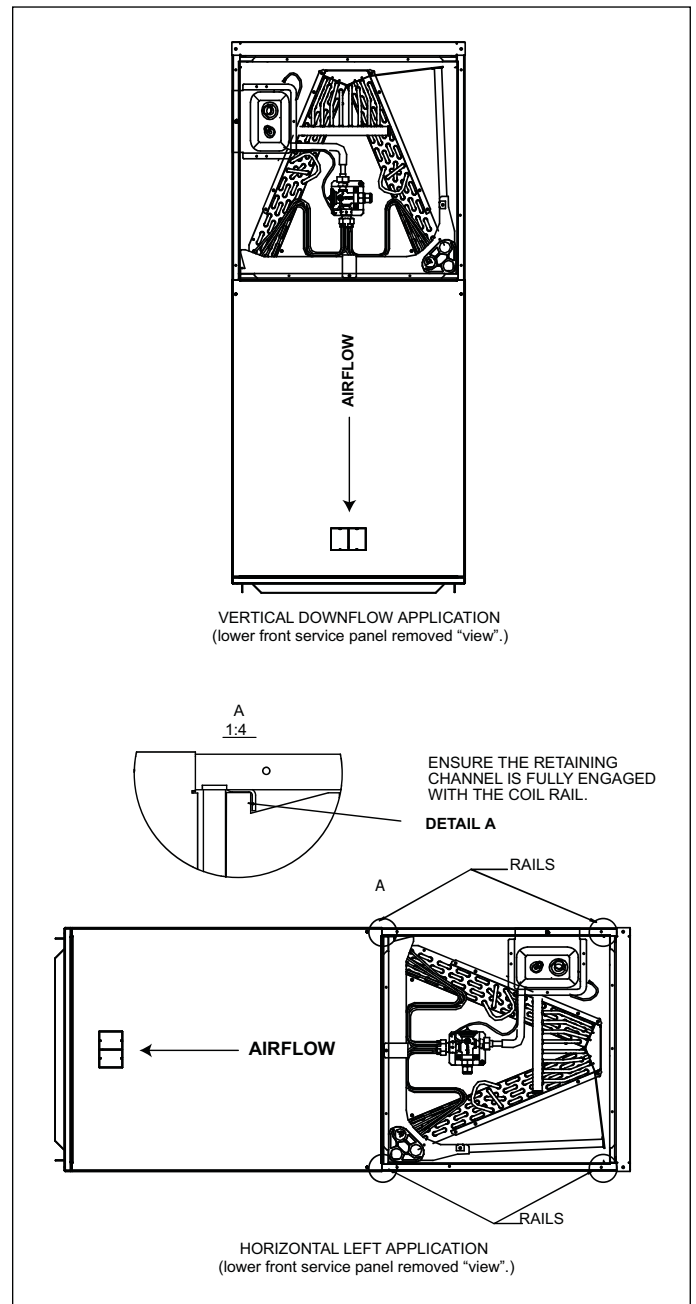

Figure 5



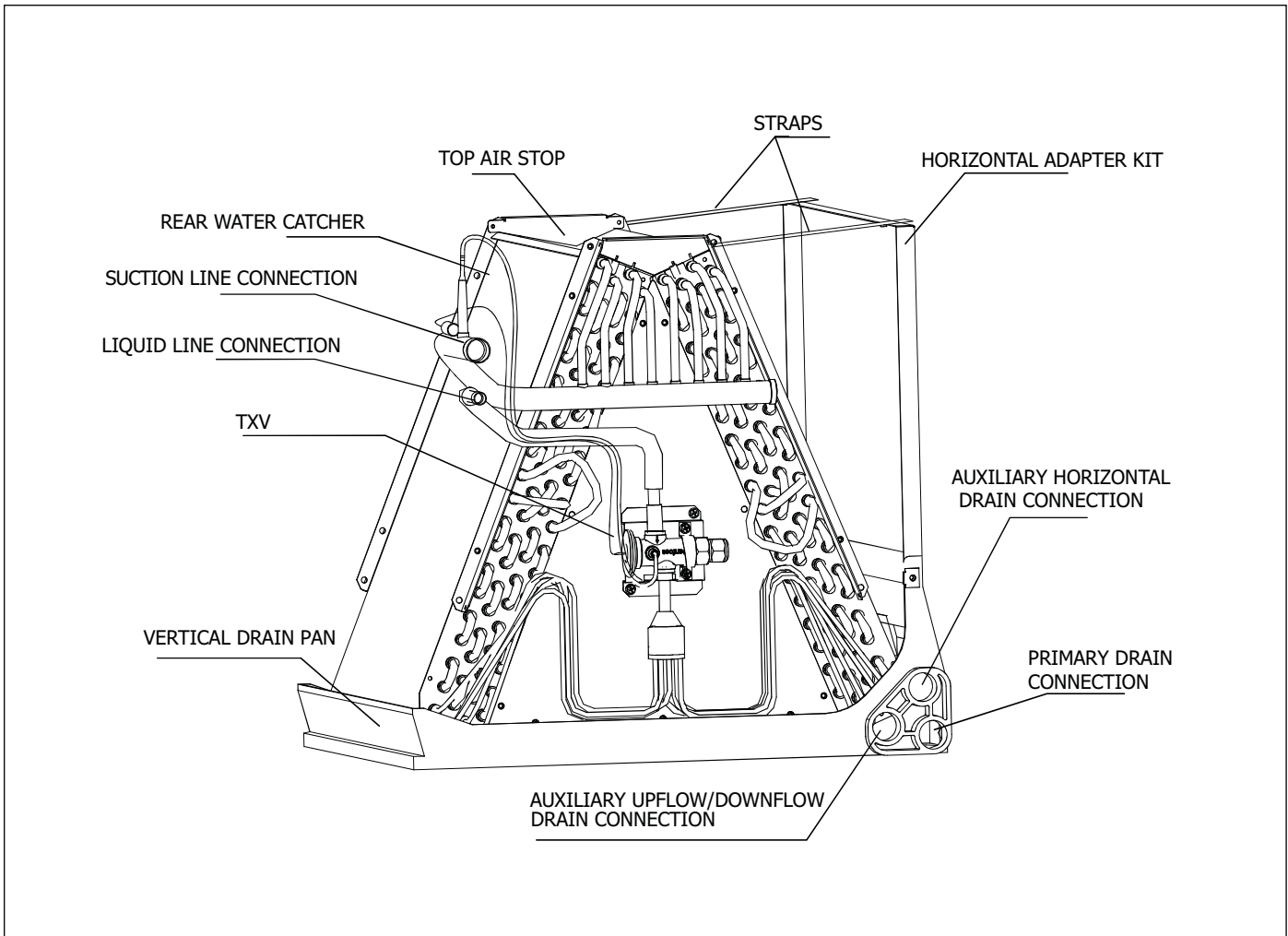

Figure 6

**CAUTION:**

- ▶ Horizontal units must be configured for right hand air supply or left hand air supply. Horizontal drain pan must be located under indoor coil. Failure to use the drain pan can result in property damage.

### 3.4 Installation in an unconditioned space



There are two pairs of coil rails in the air handler for default and counter flow application. If the air handler is installed in an unconditioned space, the two unused coil rails should be removed to minimize air handler surface sweating. The coil rails can be easily removed by taking off the 6 mounting screws from both sides of the cabinet.

## 4 Electrical wiring

Field wiring must comply with the National Electric Code (C.E.C. in Canada) and any applicable local ordinance.



### WARNING: HAZARDOUS VOLTAGE

- ▶ Disconnect all power to unit before installing or servicing. More than one disconnect switch may be required to deenergize the equipment. Hazardous voltage can cause severe personal injury or death.

### 4.1 Power wiring

It is important that proper electrical power is available for connection to the unit being installed. See the unit nameplate, wiring diagram and electrical data in the installation instructions.

- ▶ If required, install a branch circuit disconnect of adequate size, located within sight of, and readily accessible from the unit.



When the Electric Heater is installed, units may be equipped with one or two 30-60 amp. circuit breakers. These breaker(s) protect the internal wiring in the event of a short circuit and serve as a disconnect. Circuit breakers installed within the unit do not provide over-current protection of the supply wiring and therefore may be sized larger than the branch circuit protection.

- ▶ Supply circuit power wiring must be 75°C minimum copper conductors only. See Electrical Data In this section for ampacity, wire size and circuit protector requirement. Supply circuit protective devices may be either fuses or "HACR" type circuit breakers.

### 4.2 Control wiring



Class 2 low voltage control wiring should not be run in conduit with main power wiring and must be separated from power wiring, unless class 1 wire of proper voltage rating is used.

- ▶ Low voltage control wiring should be 18 Awg. color-coded. For lengths longer than 100 ft., 16 Awg. wire should be used.
- ▶ Low voltage control connections are made to low voltage pigtails within air handler control box.
- ▶ See wiring diagrams attached to indoor and outdoor sections to be connected.
- ▶ Make sure, after installation, separation of control wiring and power wiring has been maintained.

## 4.3 Grounding



### WARNING:

- ▶ The unit must be permanently grounded. Failure to do so can result in electrical shock causing personal injury or death.

- ▶ Grounding may be accomplished by grounding metal conduit when installed in accordance with electrical codes to the unit cabinet.
- ▶ Grounding may also be accomplished by attaching ground wire(s) to ground lug(s) provided in the unit wiring compartment.
- ▶ Use of multiple supply circuits require grounding of each circuit to lug(s) provided in unit.

## 4.4 Electrical data

Model	Voltage	Hertz	HP	Speeds	Circuit Amps	Maximum Circuit Protector
24	208/230	60	1/3	5	3.5	15(A)
36	208/230	60	1/2	5	5.1	15(A)
48	208/230	60	3/4	5	7.5	15(A)
60	208/230	60	3/4	5	7.5	15(A)

Table 2

## 4.5 Electrical kit MCA/MOP data

Heat Kit Model	Air Handler Model	(kW)Electric Heat	MIN. Circuit Ampacity		MAX. Fuse or Breaker (HACR) Ampacity		Fan Speed				
			240 VAC	208 VAC	240 VAC	208 VAC	1	2	3	4	5
WEHK05A	24	5	28.5	24.9	30	25	●	●	●	●	●
WEHK08A		7.5	41.5	36.3	45	40	X	X	●	●	●
WEHK10A		10	54.5	47.6	60	50	X	X	●	●	●
WEHK05A	36	5	29.7	26.2	30	30	●	●	●	●	●
WEHK08A		7.5	42.7	37.5	45	40	X	●	●	●	●
WEHK10A		10	55.8	48.8	60	50	X	X	●	●	●
WEHK15B		15	55.8+26.1	48.8+22.6	60+30	50+25	X	X	●	●	●
			81.8*	75.3*	90*	80*					
WEHK05A	48	5	33.6	30.1	35	35	●	●	●	●	●
WEHK08A		7.5	46.6	41.4	50	45	●	●	●	●	●
WEHK10A		10	59.6	52.7	60	60	X	●	●	●	●
WEHK15B		15	59.6+26.1	52.7+22.6	60+30	60+25	X	X	●	●	●
			85.7*	75.3*	90*	80*					
WEHK20B	20	59.6+52.1	52.7+45.2	60+60	60+50	X	X	X	●	●	
		111.7*	97.8*	125*	100*						
WEHK05A	60	5	33.6	30.1	35	35	X	X	●	●	●
WEHK08A		7.5	46.6	41.4	50	45	X	X	●	●	●
WEHK10A		10	59.6	52.7	60	60	X	X	●	●	●
WEHK15B		15	59.6+26.1	52.7+22.6	60+30	60+25	X	X	●	●	●
			85.7*	75.3*	90*	80*					
WEHK20B	20	59.6+52.1	52.7+45.2	60+60	60+50	X	X	X	●	●	
		111.7*	97.8*	125*	100*						

Table 3

Heat kit suitable for AHU multi position installation.

[ ● means available, X means not available, \* means single circuit ]

### Heater Kit Accessories

Model	Description	24	36	48	60
WEHK05A	5kW Heat Kit, Double Pole Breaker	●	●	●	●
WEHK08A	7.5kW Heat Kit, Double Pole Breaker	●	●	●	●
WEHK10A	10kW Heat Kit, Double Pole Breaker	●	●	●	●
WEHK15B	15kW Heat Kit, Double Pole Breaker	X	●	●	●
WEHK20B	20kW Heat Kit, Double Pole Breaker	X	X	●	●

Table 4

[ ● means available, X means not available ]

## 5 Airflow performance

Airflow performance data is based on cooling performance with a coil and no filter in place. Check the performance table for appropriate unit size selection. External static pressure should stay within the minimum and maximum limits shown in the table below in order to ensure proper operation of both cooling, heating, and electric heating operation.

Air Handler Model Size	Motor Speed		SCFM									
			External Static Pressure-Inches W.C. [kPa]									
				0.1[.02]	0.2[.05]	0.3[.07]	0.4[.10]	0.5[.12]	0.6[.15]	0.7[.17]	0.8[.20]	
24	Tap(5)	SCFM	1016	955	914	870	827	790	741	691	657	
		Watts	139	146	157	165	174	185	195	202	209	
	Tap(4)	SCFM	955	892	853	804	768	729	671	630	---	
		Watts	118	125	135	142	152	162	169	178	---	
	Tap(3) -Default Setting	SCFM	927	829	789	739	701	643	597	---	---	
		Watts	109	105	113	121	131	137	147	---	---	
	Tap(2)	SCFM	887	766	671	631	567	522	465	---	---	
		Watts	97	87	83	93	99	108	112	---	---	
	Tap(1)	SCFM	829	698	547	366	347	277	234	---	---	
		Watts	81	71	60	54	60	64	72	---	---	
	36	Tap(5)	SCFM	1452	1403	1343	1287	1214	1144	1085	1022	968
			Watts	253	264	271	284	296	303	313	324	329
Tap(4) -Default Setting		SCFM	1255	1203	1150	1062	995	920	854	797	719	
		Watts	170	182	193	201	212	221	229	239	244	
Tap(3)		SCFM	1109	1050	985	897	841	841	766	702	617	
		Watts	126	136	147	154	164	170	180	187	195	
Tap(2)		SCFM	1020	907	818	733	673	586	520	---	---	
		Watts	103	98	109	114	124	129	139	---	---	
Tap(1)		SCFM	962	807	627	551	450	380	296	---	---	
		Watts	90	80	71	79	83	93	96	---	---	
48		Tap(5)	SCFM	2072	2013	1935	1923	1878	1830	1783	1736	1688
			Watts	447	464	489	497	514	530	545	558	570
	Tap(4)	SCFM	1860	1816	1735	1679	1640	1591	1542	1504	1481	
		Watts	348	364	383	395	408	418	429	451	463	
	Tap(3) -Default Setting	SCFM	1702	1651	1560	1547	1497	1438	1385	1331	1280	
		Watts	268	281	304	312	325	337	349	361	375	
	Tap(2)	SCFM	1393	1358	1179	1155	1139	1074	1020	964	896	
		Watts	227	234	258	269	270	283	296	313	325	
	Tap(1)	SCFM	1365	1239	1078	1050	965	904	886	831	797	
		Watts	220	226	243	264	269	281	293	301	317	
	60	Tap(5)	SCFM	2054	2015	1947	1928	1886	1846	1804	1742	1654
			Watts	470	495	518	528	542	553	569	567	548
Tap(4) -Default Setting		SCFM	1883	1840	1783	1754	1712	1670	1622	1579	1541	
		Watts	367	388	411	420	422	445	454	466	479	
Tap(3)		SCFM	1721	1674	1582	1566	1528	1484	1443	1401	1345	
		Watts	289	305	327	330	341	353	365	378	387	
Tap(2)		SCFM	1515	1463	1386	1358	1308	1262	1215	1153	1073	
		Watts	205	218	235	239	251	263	276	285	301	
Tap(1)		SCFM	1337	1265	1156	1148	1095	984	955	963	789	
		Watts	145	157	173	178	186	197	212	225	235	

Table 5

- Bold outlined areas represent airflow outside of the required 300-450 cfm/ton range.



SCFM means Standard Cubic Foot per Minute.



Airflow based upon Air Handler Unit operating at 230V with no electric heater kit and no filter. Airflow at 208V is approximately the same as 230V.

The air distribution system has the greatest effect on airflow. The duct system is totally controlled by the contractor. For this reason, the contractor should use only industry-recognized procedures.

Heat pump systems require a specified airflow. Each ton of cooling requires between 350 and 450 cubic feet of air per minute (CFM), or 400 CFM nominally. Duct design and construction should be carefully done. System performance can be lowered dramatically through bad planning or workmanship.

Air supply diffusers must be selected and located carefully. They must be sized and positioned to deliver treated air along the perimeter of the space. If they are too small for their intended airflow, they become noisy. If they are not located properly, they cause drafts. Return air grilles must be properly sized to carry air back to the blower. If they are too small, they also cause noise.

The installers should balance the air distribution system to ensure proper quiet airflow to all rooms in the home. This ensures a comfortable living space. An air velocity meter or airflow hood can be used to balance and verify branch and system airflow (CFM).

## 6 Ductwork

Field ductwork must comply with the National Fire Protection Association NFPA 90A, NFPA 90B and any applicable local ordinance.



### WARNING:

- ▶ Do not, under any circumstances, connect return ductwork to any other heat producing device such as fireplace insert, stove, etc. Unauthorized use of such devices may result in fire, carbon monoxide poisoning, explosion, personal injury or property damage.

Sheet metal ductwork run in unconditioned spaces must be insulated and covered with a vapor barrier. Fibrous ductwork may be used if constructed and installed in accordance with SMACNA Construction Standard on Fibrous Glass Ducts. Ductwork must comply with National Fire Protection Association as tested by U/L Standard 181 for Class I Air Ducts. Check local codes for requirements on ductwork and insulation.

- ▶ Duct system must be designed within the range of external static pressure the unit is designed to operate against. It is important that the system airflow be adequate. Make sure supply and return ductwork, grills, special filters, accessories, etc. are accounted for in total resistance. See airflow performance tables in this manual.
- ▶ Design the duct system in accordance with "ACCA" Manual "D" Design for Residential Winter and Summer Air Conditioning and Equipment Selection. Latest editions are available from: "ACCA" Air Conditioning Contractors of America, 1513 16th Street, N.W., Washington, D.C. 20036. If duct system incorporates flexible air duct, be sure pressure drop information (straight length plus all turns) shown in "ACCA" Manual "D" is accounted for in system.
- ▶ Supply plenum should be attached to the 3/4" duct flanges supplied with the unit. Attach flanges around the blower outlet.



If an elbow is included in the plenum close to the unit, it must not be smaller than the dimensions of the supply duct flange on the unit.



The front flange on the return duct if connected to the blower casing must not be screwed into the area where the power wiring is located. Drills or sharp screw points can damage insulation on wires located inside unit.

- ▶ Secure the supply and return ductwork to the unit flanges, using proper fasteners for the type of duct used and tape the duct-to-unit joint as required to prevent air leaks.

## 7 Refrigerant connections

Keep the coil connections sealed until refrigerant connections are made. See the Installation Instructions for the outdoor unit for details on line sizing, tubing installation, and charging information.

Coil is shipped filled with Nitrogen. Evacuate the system before charging with refrigerant.

Install refrigerant lines so that it does not block service access to the front of the unit. Nitrogen should flow through the refrigerant lines while brazing.

Use a wet rag or an approved heat paste to protect the TXV sensing bulb during the brazing process.

After the refrigerant line connections are made, seal the gap around the connections with pressure sensitive gasket.

### 7.1 Condensate drain connection

Consult local codes for specific requirements.

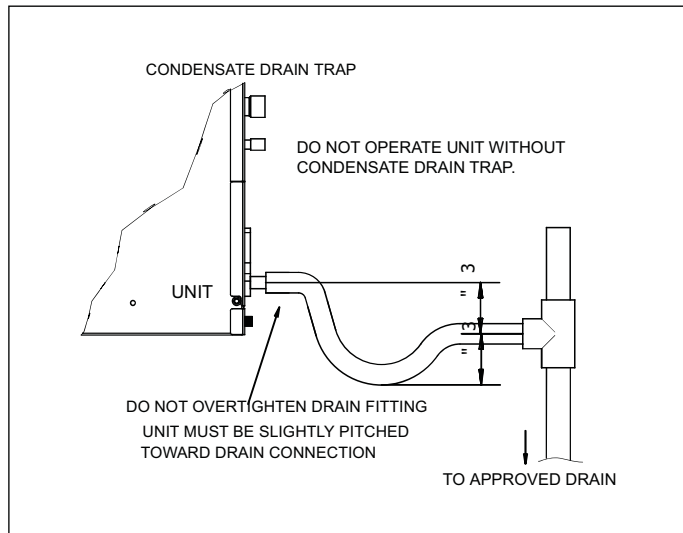

Figure 7

- i** 1. When making drain fitting connections to the drain pan, use a thin layer of Teflon paste, silicone or Teflon tape and install, hand tighten.
- 2. When making drain fitting connections to drain pan, do not overtighten. Over tightening fittings can split pipe connections on the drain pan.

- ▶ Install drain lines so they do not block service access to front of the unit. Minimum clearance of 24 inches is required for filter, coil or blower removal and service access.
- ▶ Make sure unit is leveled or pitched slightly toward primary drain connection so that water will drain completely from the pan. (See Fig. 7)
- ▶ Do not reduce drain line size to less than connection size provided on condensate drain pan.
- ▶ All horizontal drain lines must be pitched downward away from the unit a minimum of 1/8" per foot of line to ensure proper drainage.

- ▶ Do not connect condensate drain line to a closed or open sewer pipe. Run condensate to an open drain or run line to a safe outdoor area.
- ▶ The drain line should be insulated where necessary to prevent sweating and damage due to condensate forming on the outside surface of the line.
- ▶ Make provisions for disconnecting and cleaning of the primary drain line should it become necessary. Install a 3 inch trap in the primary drain line as close to the unit as possible. Make sure that the top of the trap is below connection to the drain pan to allow complete drainage of pan (See Fig. 7).
- ▶ Auxiliary drain line should be run to a place where condensate will be noticeable. Homeowner should be warned that a problem exists if water should begin running from the auxiliary drain line.
- ▶ Plug the unused drain connection with the plugs provided in the parts bag, using a thin layer of teflon paste, silicone or teflon tape to form a water tight seal.
- ▶ Test condensate drain pan and drain line after installation is complete. Pour water into drain pan, enough to fill drain trap and line. Check to make sure drain pan is draining completely, no leaks are found in drain line fittings, and water is draining from the termination of the primary drain line.

## 8 Air filter (not factory-installed)

An external filter or other means of filtration must be properly sized for a maximum of 300 feet/min. air velocity or what is recommended for the type filter installed.

Filter application and placement are critical to airflow, which may affect the heating and cooling system performance. Reduced airflow can shorten the life of the system's major components, such as motor, elements, heat relays, evaporator coil or compressor. Consequently, we recommend that the return air duct system have only one filter location. For systems without a return air filter grill, multiple filter grills can be installed at each of the return air openings.

If adding high efficiency filters or electronic air filtration systems, it is very important that the air flow is not reduced. If air flow is reduced the overall performance and efficiency of the unit will be reduced. It is strongly recommended that a professional installation technician is contacted to ensure such filtration systems are installed correctly.

- i** Do not double filter the return air duct system. Do not filter the supply air duct system. This will change the performance of the unit and reduce airflow.



### WARNING:

- ▶ Do not operate the system without filters. A portion of the dust suspended in the air may temporarily lodge in the duct runs and at the supply registers. Any circulated dust particles could be heated and charred by contact with the air handler elements. This residue could soil ceilings, walls, drapes, carpets and other articles in the house. Soot damage may occur with filters in place, when certain types of candles, oil lamps or standing pilots are burned.

## 9 Filter installation dimensions

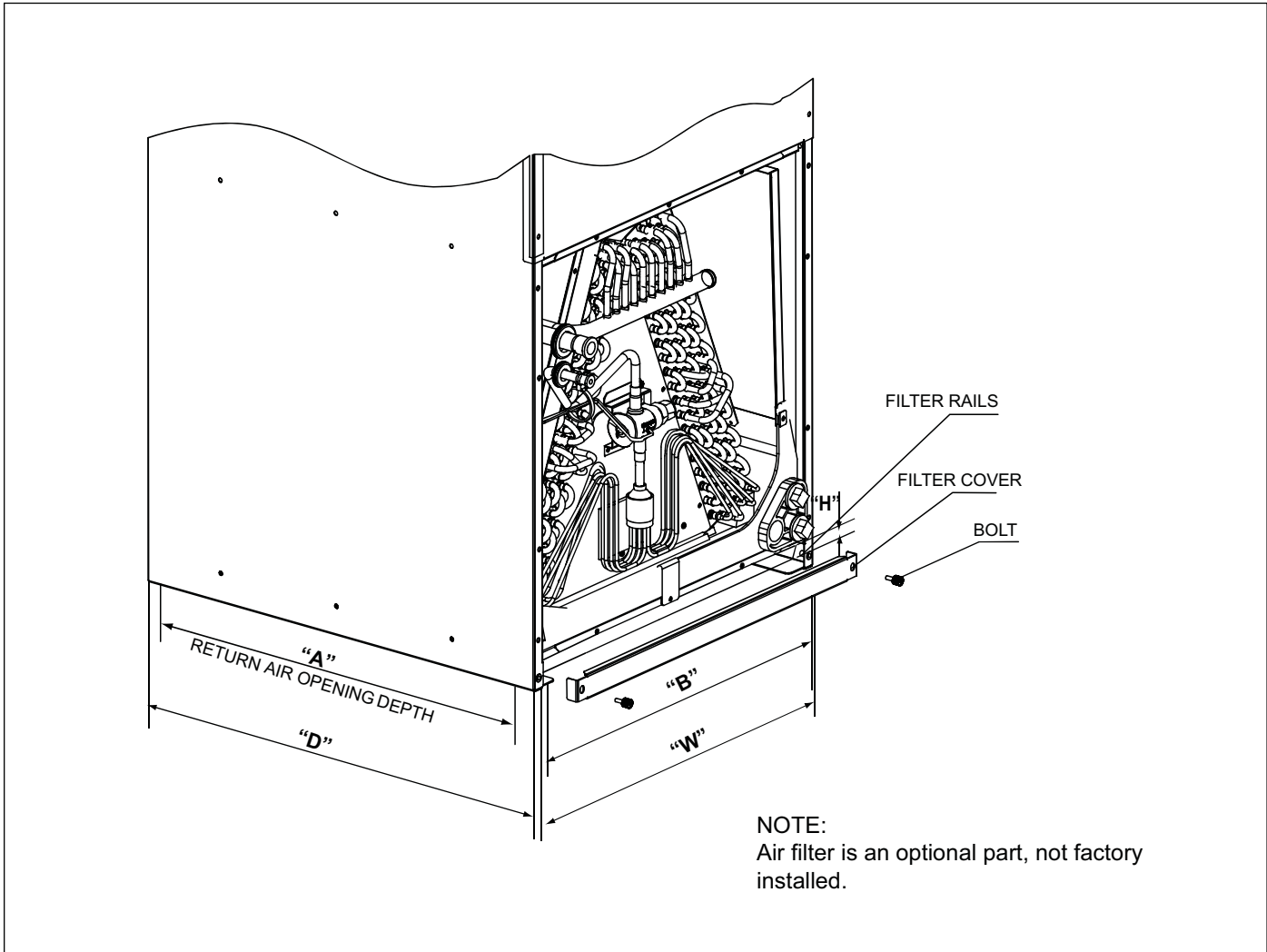

Figure 8

### Dimensional data

Model	Filter Size IN [mm]"	"W" IN [mm]	"D" IN [mm]	"H" IN [mm]	Return width "A" IN	Return length "B" IN
24/36	18X20[457X508]	18.3[466]	21.6[548]	1[25.4]	20.8	16.3
48/60	20X22[508X559]	20.7[526]	23.9[608]	1[25.4]	23	18.8

Table 6

### Air filter removal / installation

- ▶ Remove bolts manually, remove air filter cover, see Fig. 6;
- ▶ Hold the edge of the air filter and extract out .
- ▶ Install new filter so that the arrow on the filter is in the same direction as airflow.

## 10 Wiring diagram



**WARNING: HIGH VOLTAGE!**

- ▶ Disconnect all power before servicing or installing this unit. Multiple power sources may be present. Failure to do so may cause property damage, personal injury or death.

- ▶ To avoid the electrical shock, please ensure the air conditioner is properly grounded. The main power plug in the air conditioner has been joined with the ground wiring, please do not alter.
- ▶ Do not strain the power wiring.

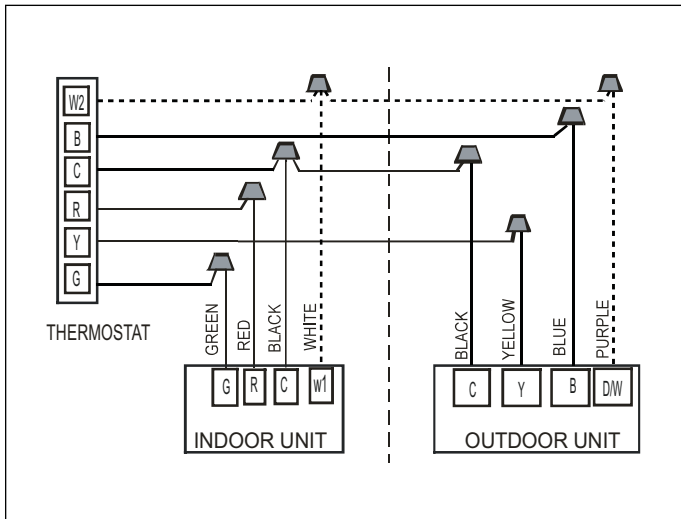

Figure 9 Control Wiring for H/P systems



Broken lines means H/P system with electric heating. Thermostat Wiring please refer to the Owner's Manual of the thermostat.

- ▶ When connecting the air conditioner with the ground, observe the local codes.
- ▶ If necessary, connect wiring to the power fuse or circuit breaker.

## Electric wiring gauge for H/P systems

Model(Btu/h)		24	36	48	60	
Power	Phase	Single				
	Voltage/frequency	208/230VAC, 60Hz				
Line Gauge	Input Current Fuse	Indoor unit (A)	15A	15A	15A	15A
	Indoor Unit Power Line	Line Quantity	3	3	3	3
		Line Diameter(AWG)	14	14	14	14
	Outdoor Unit Power Line	Line Quantity	3	3	3	3
		Line Diameter(AWG)	14	12	10	10
	Outdoor-Indoor Signal Line	Line Quantity	4	4	4	4
Line Diameter(AWG)		18	18	18	18	
Thermostat Signal Line	Line Quantity	5	5	5	5	
	Line Diameter(AWG)	18	18	18	18	

Table 7



If indoor unit has auxiliary heating already installed and a different auxiliary heating unit is required, the indoor unit (A) and indoor line diameters will be different.



**WARNING:**

- ▶ These units must be wired and installed in accordance with all National and Local Safety Codes.



**For ECM Motor (Size 24/48K)**

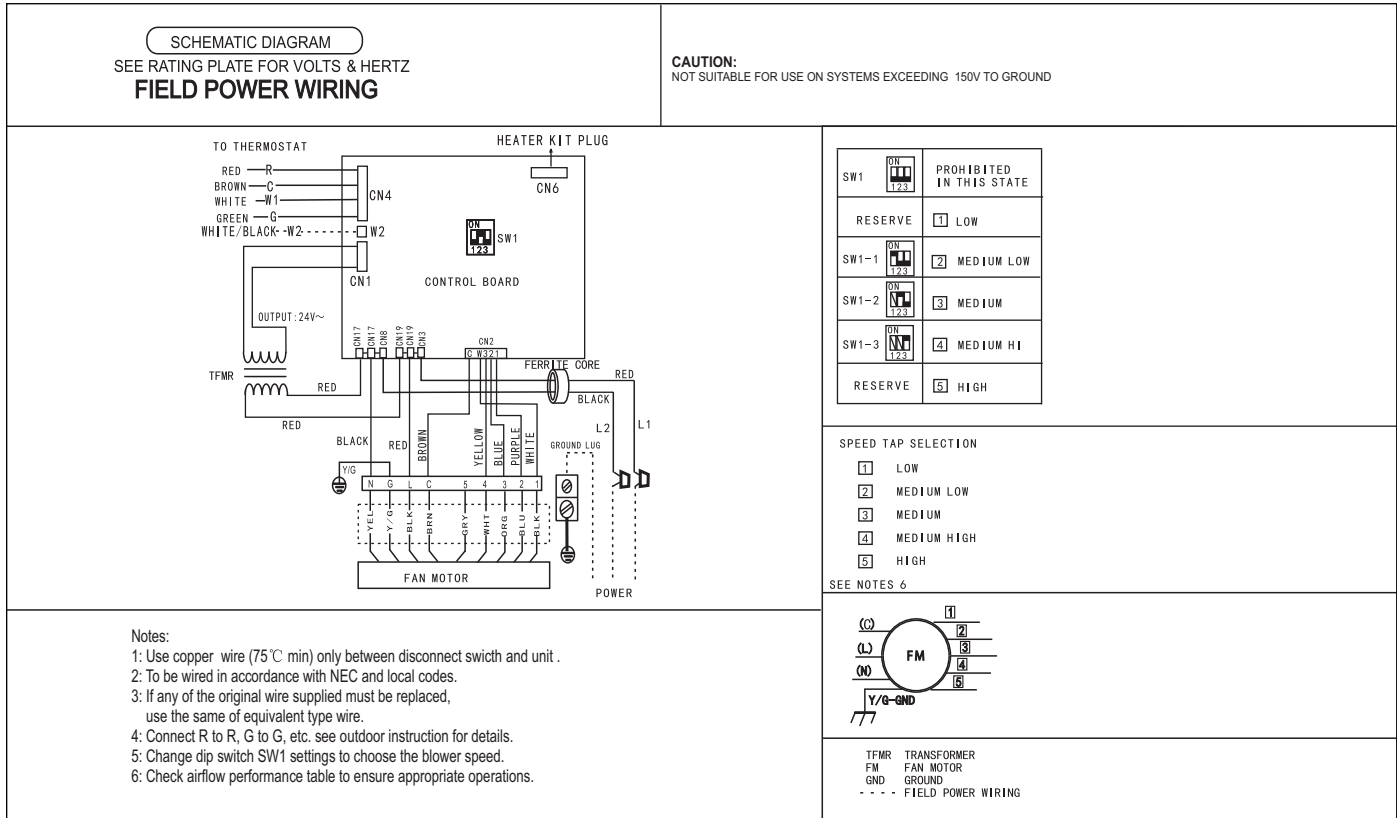

Figure 10

**For ECM Motor (Size 36/60K)**

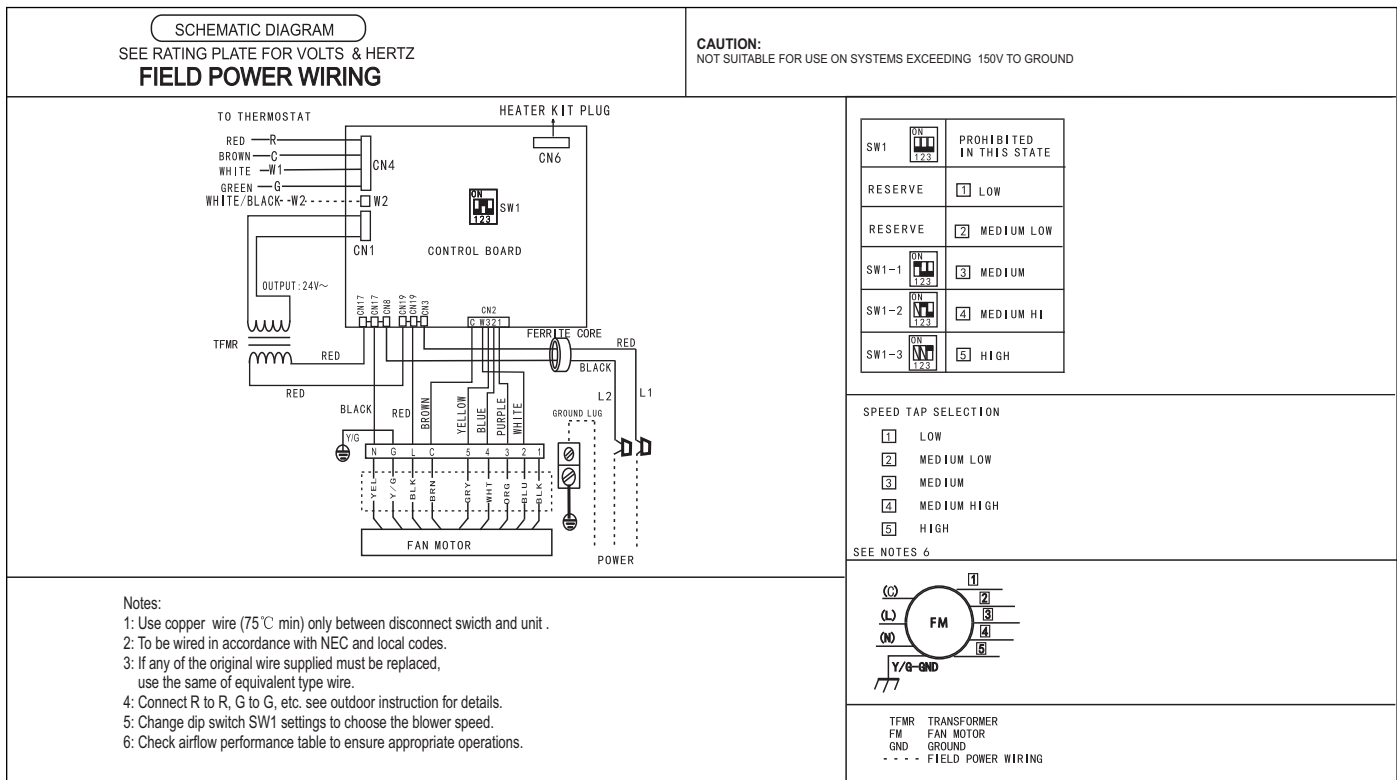

Figure 11

Unit Wiring

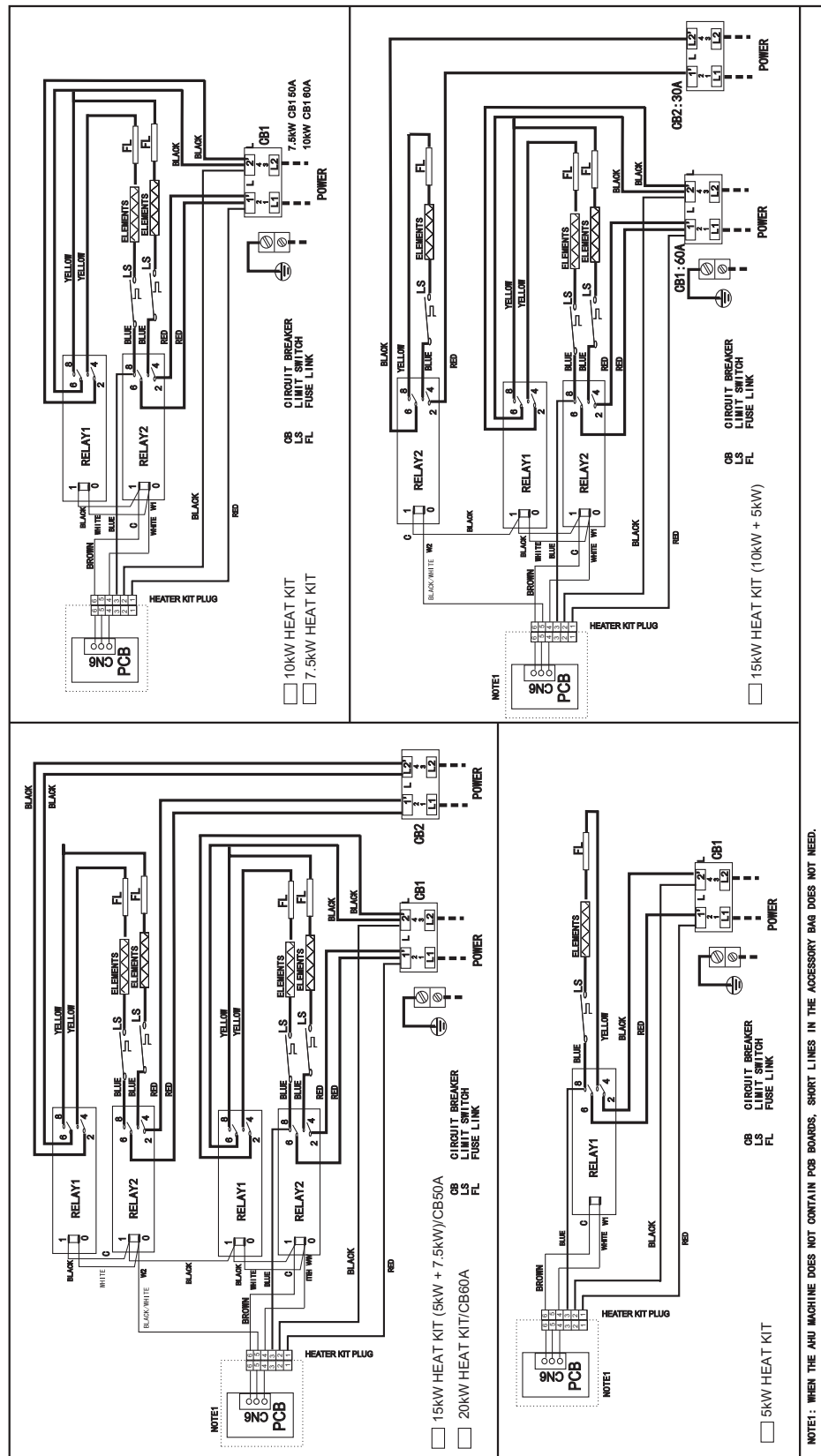

Figure 12

## 11 Spare parts

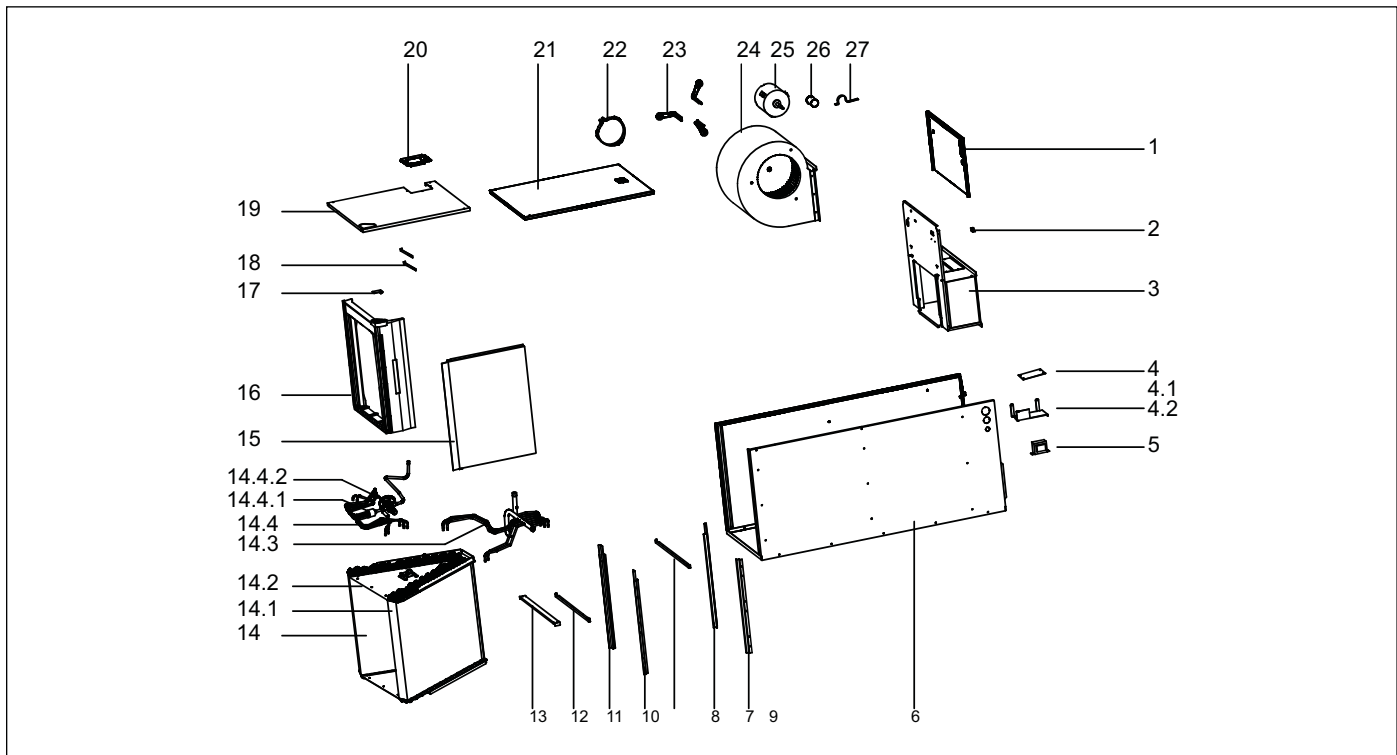

Figure 13

No.	Part Name	Qty	BVA 24 (2 Ton)	BVA 36 (3 Ton)	BVA 48 (4 Ton)	BVA 60 (5 Ton)
1	Top Pan, Cabinet	1	8733941881	8733941910	8733941910	8733941910
2	Ground Lug	1	8733941882	8733941882	8733941882	8733941882
3	Duct, Discharge	1	8733941883	8733941911	8733941911	8733941911
4	Main Control Board, Assy	1	8733941884	8733941884	8733941884	8733941884
4.1	Main Control Board	1	8733941885	8733941885	8733941885	8733941885
4.2	Bracket, Mounting	1	8733941886	8733941886	8733941886	8733941886
5	Transformer	1	8733941887	8733941887	8733941887	8733941887
6	Wrapper, Cabinet	1	8733941888	8733941912	8733941912	8733941912
7	Downflow Coil Support (Right)	1	8733941889	8733941913	8733941913	8733941913
8	Downflow Coil Support (Left)	1	8733941890	8733941914	8733941914	8733941914
9	Support Bracket (Middle)	1	8733941891	8733941915	8733941915	8733941915
10	Upflow Coil Support (Right)	1	8733941892	8733941916	8733941916	8733941916
11	Upflow Coil Support (Left)	1	8733941893	8733941917	8733941917	8733941917
12	Support Bracket (Lower)	1	8733941894	8733941918	8733941918	8733941918
13	Cover, Filter	1	8733941895	8733941919	8733941919	8733941919
14	Evaporator Assy	1	8733941896	8733941920	8733941928	8733941931
14.4.1	Distributor	1	8733941897	8733941921	8733941921	8733941921
14.4.2	Expansion valve	1	8733941898	8733941898	8733941929	8733941932
15	Drain Pan, Horizontal	1	8733941899	8733941922	8733941922	8733941922
16	Drain Pan, Vertical	1	8733941900	8733941923	8733941923	8733941923
17	Drain Pan Clamp	1	8733941901	8733941901	8733941901	8733941901
18	Drain Pan Support	2	8733941902	8733941902	8733941902	8733941902
19	Coil Door, Cabinet	1	8733941903	8733941924	8733941924	8733941924
20	Plate, Refrig Line Access	1	8733941904	8733941904	8733941904	8733941904
21	Blower Door, Cabinet	1	8733941905	8733941925	8733941925	8733941925
22	Mounting Bracket, Motor	1	8733941906	8733941906	8733941906	8733941906
23	Mounting Legs, Motor	3	8733941907	8733941907	8733941907	8733941907
24	Blower Assy, Wrapper/Wheel	1	8733941908	8733941926	8733941926	8733941926
25	Blower Motor	1	8733941909	8733941927	8733941930	8733941930

Table 8

**United States and Canada**

**Bosch Thermotechnology Corp.  
50 Wentworth Avenue  
Londonderry, NH 03053**

**Tel: 866-305-9974**

**Fax: 603-965-7581**

**[www.boschheatingandcooling.com](http://www.boschheatingandcooling.com)**