

# P70, P72, and P170 Series Controls for Dual Pressure Applications

## Installation Instructions

Part No. 24-8607-0, Rev. J  
Issued September 2018

---

### Applications

The P70, P72, and P170 Controls for Dual Pressure Applications provide combined high and low pressure control of compressors on commercial refrigeration and air conditioning applications.

**IMPORTANT:** Except for those models listed as refrigeration temperature limiting controls, use this P70, P72, and P170 Series Controls for Dual Pressure Applications only as an operating control. Where failure or malfunction of the P70, P72, or P170 Pressure Control could lead to personal injury or property damage to the controlled equipment or other property, additional precautions must be designed into the control system. Incorporate and maintain other devices, such as supervisory or alarm systems or safety or limit controls, intended to warn of or protect against failure or malfunction of the P70, P72, or P170 Pressure Control.

P70S and P170S models have independently operated high and low pressure Single-Pole Double-Throw (SPDT) switches that can be wired to satisfy a variety of control requirements. These adaptable controls have a high pressure manual reset lockout mechanism that is convertible to automatic reset. See Table 1.

P70L, M, N, and P170L, M, N models have a Single-Pole Single-Throw (SPST) switch. Models are available with automatic or manual reset lockout options. Models with manual reset are available with either high-side-only manual reset, or low-side and high-side manual reset. (See Table 1 and Table 3.) Ammonia compatible models are available (P70L and P70M only). See Table 2.

P72 models have a Double-Pole Single-Throw (DPST) switch with load-carrying contacts that can provide direct control of 208/240 VAC, single-phase motors up to 3 hp, 480, and 600 VAC single-phase non-compressor motors and 208/220 VAC, 3-phase motors up to 5 hp. See Table 3.

These controls are available in several pressure ranges and are compatible with most common refrigerants. Ammonia-compatible models are also available (P70L and P70M only). See Table 2.

The MICRO-SET® option provides fine adjustment of the differential setting for precision pressure control of low pressure applications.

Some models feature Limited Knob Adjustment, which restricts adjustment of the pressure settings and deters over-adjustment or tampering. See [\*Low Pressure Limited Knob Adjustment\*](#).

A Manual Reset Lockout option does not allow the pressure control to reset automatically after CUT OUT is reached, and provides shutdown capability for unmonitored equipment. See [\*Manual Reset Operation\*](#).

NEMA 1 enclosures are standard on most models. NEMA 3R enclosures are also available.

Table 1 through Table 2 list the standard models and features of P70, P72, and P170 controls for dual pressure applications. These standard models are available through most authorized Johnson Controls/PENN® distributors.



**Table 1: Standard Model P70, P72, and P170 MICRO-SET® Dual Pressure Controls for Non-Corrosive Refrigerants**

Model Code Number	Switch Action	Low Pressure Side psig (kPa)		High Pressure Side psig (kPa)		Pressure Connector	Limited Knob Adjustment
		Range	Differential	Range	Differential (Non-Adjustable)		
<b>P70LB-6<sup>1</sup></b>	SPST	12 in. Hg to 80 psig (-41 to 552)	Min 5 (34) Max 35 (241)	100 to 500 (690 to 3,447)	Fixed Approximately 65 (448)	36 in. Capillary with 1/4 in. Flare Nut	Low CUT OUT
<b>P70MA-18<sup>1</sup></b>					Lockout Requires Manual Reset		
<b>P70SA-1<sup>1</sup></b>					Two Independent SPDT		Fixed at 65 (448) or Lockout Requires Manual Reset
<b>P170LB-6<sup>1</sup></b>	SPST				Fixed Approximately 65 (448)	1/4 in. Male Flare Connector	Low CUT OUT
<b>P170MA-18<sup>1</sup></b>					Lockout Requires Manual Reset		None
<b>P170SA-1<sup>1</sup></b>	Two Independent SPDT				Fixed at 65 (448) or Lockout Requires Manual Reset		

1. Control models with high pressure side (only) that are UL Listed as Refrigeration Pressure Limiting Controls.

**Table 2: Standard Model P70, P72, and P170 All Range Dual Pressure Controls for Ammonia**

Model Code Number	Switch Action	Low Pressure Side psig (kPa)		High Pressure Side psig (kPa)		Pressure Connector	Limited Knob Adjustment
		Range	Differential	Range	Differential (Non-Adjustable)		
<b>P70LA-2<sup>1</sup></b>	SPST	20 in. Hg to 100 psig (-68 to 690)	Min 7 (48) Max 50 (345)	100 to 500 (690 to 3,447)	Fixed Approximately 65 (448)	1/4 in. Female NPT Connector	None
<b>P70MA-2<sup>1</sup></b>					Lockout Requires Manual Reset		

1. Control models with high pressure side (only) that are UL Listed as Refrigeration Pressure Limiting Controls.

**Table 3: Standard Model P70, P72, and P170 All Range Dual Pressure Controls for Non-Corrosive Refrigerants**

Model Code Number	Switch Action	Low Pressure Side psig (kPa)		High Pressure Side psig (kPa)		Pressure Connector	Limited Knob Adjustment
		Range	Differential	Range	Differential (Non-Adjustable)		
<b>P70LB-1<sup>1</sup></b>	SPST	20 in. Hg to 100 psig (-68 to 690)	Min 6 (41) Max 50 (345)	100 to 500 (690 to 3,447)	Fixed Approximately 65 (448)	36 in. Capillary with 1/4 in. Flare Nut	Low CUT OUT
<b>P70MA-1<sup>1</sup></b>			Fixed (Manual Reset)		Lockout Requires Manual Reset		None
<b>P70NA-1</b>							
<b>P72LA-1<sup>1</sup></b>	DPST		Min 7 (48) Max 50 (345)		Fixed Approximately 65 (448)		None
<b>P72LB-1<sup>1</sup></b>			Fixed (Manual Reset)		Lockout Requires Manual Reset		Low CUT OUT
<b>P72MA-1<sup>1</sup></b>							None
<b>P72NA-1<sup>1</sup></b>							
<b>P170LB-1<sup>1</sup></b>	SPST		Min 7 (48) Max 50 (345)		Fixed Approximately 65 (448)	1/4 in. Male Flare Connector	Low CUT OUT
<b>P170MA-1<sup>1</sup></b>			Fixed (Manual Reset)		Lockout Requires Manual Reset		None
<b>P170NA-1</b>							

1. Control models with high pressure side (only) that are UL Listed as Refrigeration Pressure Limiting Controls.

## Installation

### Dimensions

See Figure 1 and Figure 2 for dimensional information.

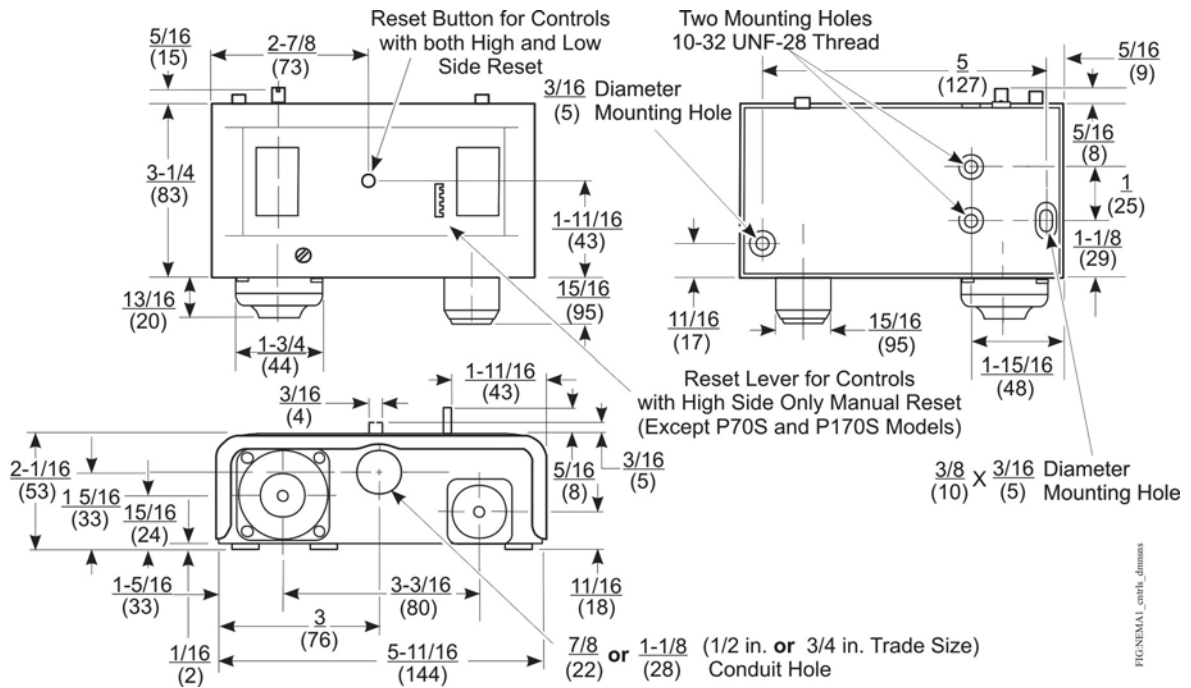

Figure 1: Dimensions for P70, P72, and P170 Dual Pressure Controls with NEMA 1 Enclosure, in.

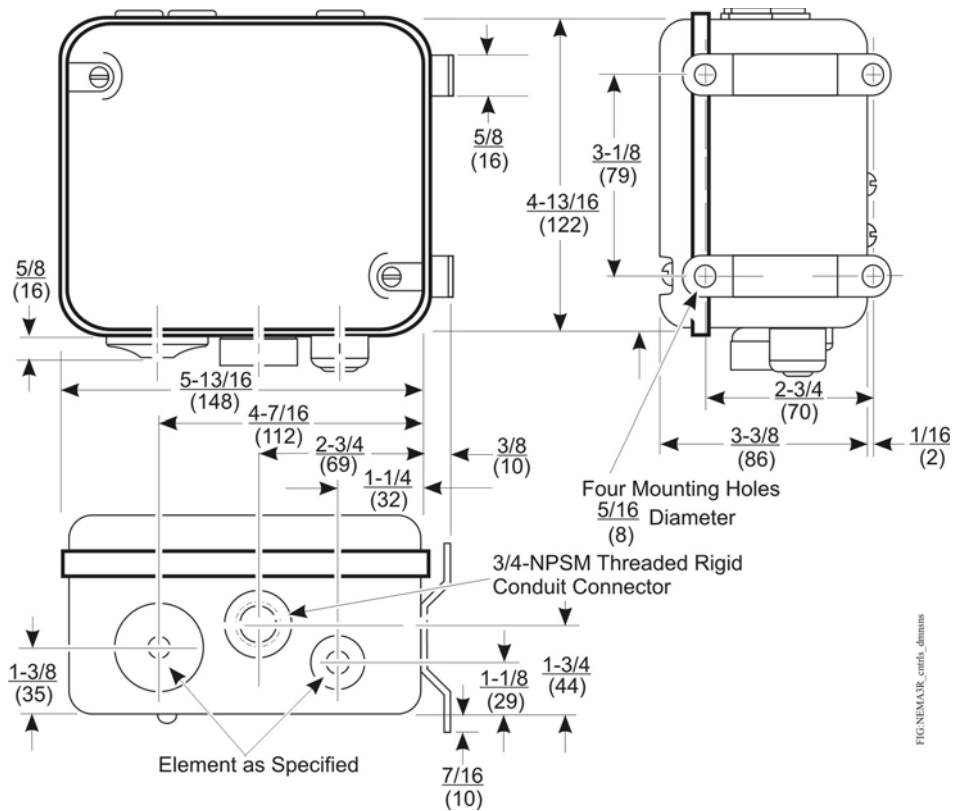

Figure 2: Dimensions for P70, P72, and P170 Dual Pressure Controls with NEMA 3R Enclosure, in.

## Mounting



### **CAUTION: Risk of Property Damage.**

Mount the pressure control separately from the electrical cabinet and seal all electrical piping to prevent ammonia from migrating to electrical components. Where there may be exposure to ammonia, use only ammonia-compatible control modules and pressure connections. System shutdown due to improper adjustment may cause property damage.



### **CAUTION: Risk of Property Damage.**

Mount the P70, P72, or P170 Pressure Control according to the instructions and guidelines included with the control. These instructions and guidelines are intended to reduce the risk of malfunction of the product and resulting property damage. Failure to follow these instructions and guidelines could cause the control to malfunction, resulting in property damage.

**IMPORTANT:** Use only the mounting screws supplied with the Universal Mounting Bracket to avoid damaging internal components. Be careful not to distort or bend the control case when mounting the control to an uneven surface. Using other screws or bending the control case will void the warranty.

Observe the following guidelines when installing this device:

- Mount the control in an accessible position, where the control and pressure-connection lines are not subject to damage.
- Mount the pressure control upright and level.
- Position the pressure-connection lines to allow drainage away from control bellows.
- Locate pressure-tap points on the topside of the refrigerant lines to reduce the possibility of oil, liquids, or sediment accumulating in the bellows, which could cause control malfunction.
- Mount controls with NEMA 1 enclosures on horizontal or vertical flat surfaces.
  - Use two screws or bolts through the two outer holes on the back of the control case when mounting the control directly to a flat vertical surface. See Figure 3.
  - Use the two inner holes with the Universal Mounting Bracket (and screws supplied) when mounting the control to a flat horizontal surface. See Figure 3.

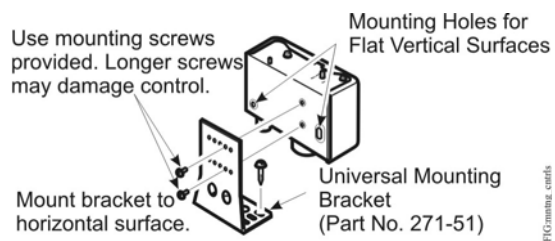

**Figure 3: Mounting Dual Pressure Controls with NEMA 1 Enclosures**

- Mount controls with NEMA 3R enclosures in a level, upright position with the bellows and conduit connection facing down. Ensure that all gaskets are in place. Mounting controls with NEMA 3R enclosures in any position other than upright and level may trap water in the enclosure and submerge internal components.

## Wiring



**WARNING: Risk of Electric Shock.**

Disconnect or isolate all power supplies before making electrical connections. More than one disconnect or isolation may be required to completely de-energize equipment. Contact with components carrying hazardous voltage can cause electric shock and may result in severe personal injury or death.

**IMPORTANT:** Use copper conductors only. Make all wiring connections in accordance with local, national, and regional regulations. Do not exceed the P70, P72, or P170 Pressure Control electrical ratings.

**IMPORTANT:** Use terminal screws furnished in the switch block. Using other terminal screws will void the warranty and may damage the switch.

P70, P72, and P170 controls for dual pressure applications are available with several switch options and electrical ratings. Check the label inside the control cover for model number, switch action, and electrical rating. Check the wiring terminal designations on the control switch block, and see the following guidelines and applicable wiring diagrams, when wiring the control. See Table 1 through Table 3 for switch actions and models. See [Technical Specifications](#).

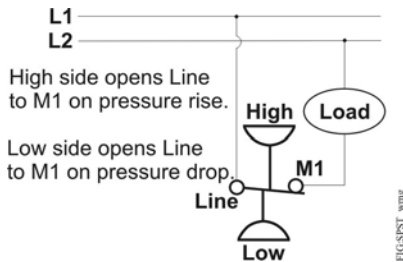

**Figure 4: Typical Wiring for SPST Switch (P70L, M, N, and P170L, M, N Models)**

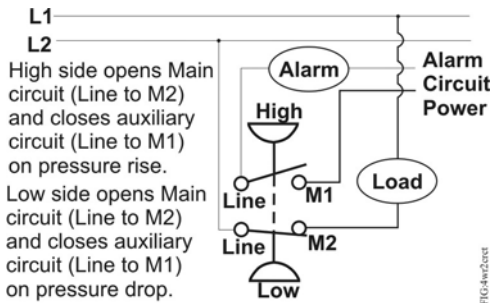

**Figure 5: Typical Wiring for 4-Wire, 2-Circuit Switch (P70P, Q and R Models)**

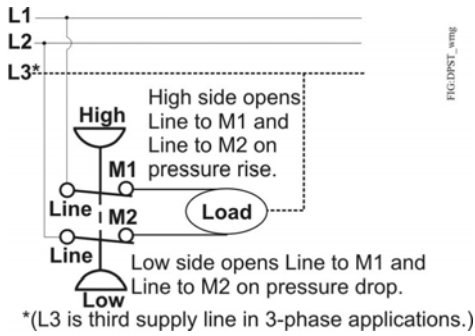

**Figure 6: Typical Wiring for DPST Switch (P72L, M, and N Models)**

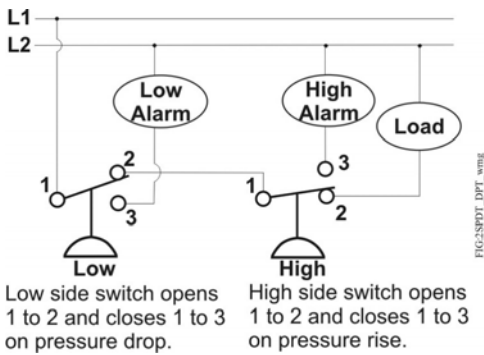

**Figure 7: Two SPDT Switches Wired as a Dual Pressure Control (P70S and P170S)**

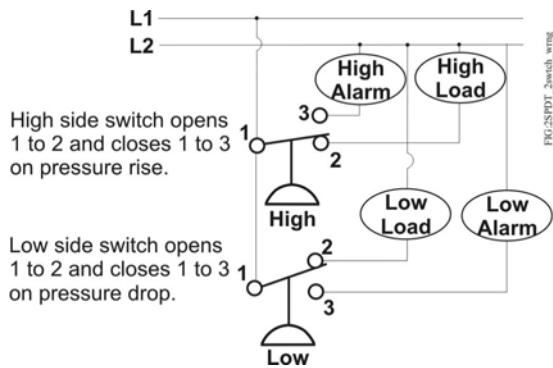

**Figure 8: Two SPDT Switches Wired to Control Two Different Loads (P70S and P170S Models)**

## Piping



**CAUTION: Risk of Environmental and Property Damage.**

Avoid sharp bends in the capillary tubes. Sharp bends can weaken or kink capillary tubes, which may result in refrigerant leaks or restrictions of flow.



**CAUTION: Risk of Environmental and Property Damage.**

Coil and secure excess capillary tubing away from contact with sharp or abrasive objects or surfaces. Vibration or sharp or abrasive objects in contact with capillary tubes can cause damage that may result in refrigerant leaks or loss of element charge, which may result in damage to the environment or property.

**IMPORTANT:** If the control is installed on equipment that contains hazardous or regulated materials such as certain refrigerants or lubricants, you must comply with all standards and regulations governing the containment and handling of those materials.

**IMPORTANT:** Do not apply more than 9 ft-lb (12 N·m) of torque to the flare nuts on pressure connection line fittings. Overtightening or applying more than 9 ft-lb (12 N·m) of torque may cause seal failure and will void the warranty.

P70, P72, and P170 dual pressure controls are typically connected to the controlled equipment by a capillary (except ammonia compatible models). These controls are available with a variety of pressure connection styles.

Avoid severe pressure pulsation at high side pressure connections. Install pressure connection to pressure-tap points away from the compressor, to minimize the effects of pressure pulsation from reciprocating compressors.

**IMPORTANT:** After installing the control, evacuate pneumatic and pressure connection lines to remove air, moisture, and other contaminants in a manner consistent with applicable environmental regulations and standards.

## Setup and Adjustments



**CAUTION: Risk of Property Damage.**

Obtain and use the compressor manufacturer's net oil bearing pressure specifications. If necessary, reset the cut-out pressure difference to the manufacturer's specifications. Using improper pressure settings may damage the control, compressor, or other controlled equipment.

**IMPORTANT:** Use the pressure control settings recommended by the manufacturer of the controlled equipment. Do not exceed the pressure ratings of the controlled equipment or any of its components when checking pressure control operation or operating the controlled equipment.

**IMPORTANT:** After mounting, wiring and evacuating the control, attach a reliable set of gauges to the controlled equipment, and operate the equipment (at least) three cycles at the pressures necessary to verify control setpoints and proper equipment operation.

Adjustment of the P70, P72, and P170 dual pressure controls varies depending on the model. The following guidelines and diagrams illustrate the procedures for adjusting these controls. Refer to the product label inside the control cover for model number and switch action, and check the front of the control cover to determine if the control is All-Range or MICRO-SET® model. See Figure 9 for an illustration and instructions on control adjustments.



### All-Range Controls (Low Side Only)

The low side of All-Range controls displays the CUT IN and CUT OUT setpoints. Turn the range screw to adjust the cut in and cutout setpoints up or down simultaneously which maintains the set differential value. Turn the differential screw to adjust the cutout setpoint and change the differential value.

### MICRO-SET® Controls (Low Side Only)

The low side of MICRO-SET® controls feature a scale plate that displays the CUT IN setpoint and DIFFERENTIAL setting. Turn the range screw to adjust the cut in setpoint. Turn the differential screw to adjust DIFFERENTIAL setting. (This changes the cutout pressure.)

### Dual Pressure Controls (High Side)

The high side scaleplate of the P70, P72, and P170 dual pressure controls displays only the CUT OUT setpoint. Turn the range screw to adjust the cutout setpoint. The differential is fixed at about 65 psi.

For controls with Manual Reset Lockout option, see [Manual Reset Operation](#). For P70S and P170S controls, see [Convertible High Pressure Reset Mechanism on P70S and P170S Controls](#).

To adjust the dual pressure controls:

1. Set the low side cut in setpoint by adjusting the low side range screw.  
All-Range Controls: Turn the screw clockwise to raise the cut in setpoint.  
MICRO-SET Controls: Turn the screw clockwise to lower the cut in setpoint.
2. Adjust the differential screw.  
All-Range Controls: Turn the screw clockwise to raise the cut out setpoint.  
MICRO-SET® Controls: Turn the screw clockwise to increase the differential value.
3. Set the high side cutout setpoint by adjusting the high side range screw. Turn the screw clockwise to raise the cutout setpoint. (The high side differential is fixed.)
4. Set the reset operation (on P70S and P170S models only) for high side automatic reset or manual reset lockout. See [Convertible High Pressure Reset Mechanism on P70S and P170S Controls](#) and Figure 9

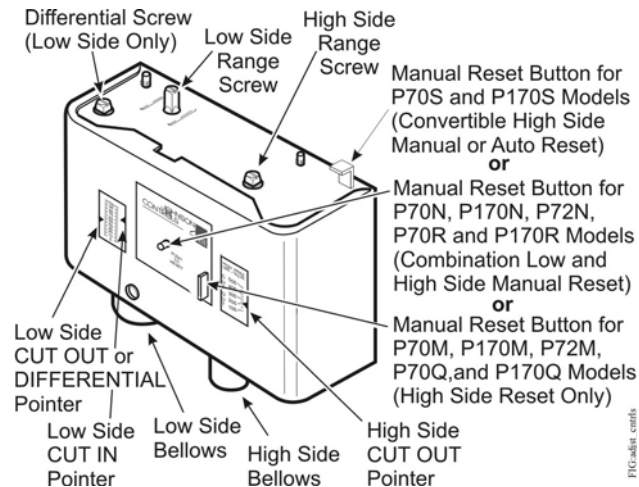

**Figure 9: Adjusting the Dual Pressure Controls**

**IMPORTANT:** Do not adjust pointers beyond the highest or lowest indicator marks on the control's pressure scale. Adjusting pointers beyond indicator marks may damage screw threads, may cause inaccurate control operation, and will void the warranty.

## Manual Reset Operation

Pressure controls, with the Manual Reset option, lock out when they reach the cutout pressure setpoint and must be manually reset by the user to restart the controlled equipment. The manual reset mechanism is trip-free and cannot be overridden by blocking or tying the reset button down.

On locked-out equipment, first determine and remedy the cause of the lockout before proceeding.

- When lockout is caused by the control's low side cutout, allow the sensed pressure to rise to the cut in setpoint.
- When lockout is caused by the control's high side cutout, allow the sensed pressure to drop at least 70 psig below the cutout setpoint.

After the sensed pressure has reached the desired pressure, press and release the Reset button to restore operation of the controlled equipment.

## Convertible High Pressure Reset Mechanism on P70S and P170S Controls

The P70S and P170S controls have a convertible high side pressure reset. The control may be set to reset automatically after cutout (when the pressure drops to cutout minus differential), or to be manually reset after cutout (by pressing down the reset lever). To change the reset operation:

1. Disconnect all power sources to the pressure control and remove the control cover.
2. **For Manual Reset Operation:** Loosen the lock nut, and unscrew the stop screw, being careful to not remove the screw completely from the bracket. See Figure 10.
- For Automatic Reset Operation:** Loosen the lock nut, push the reset lever down, and screw in the stop screw fully. See Figure 10.
3. Tighten the lock nut to hold the stop screw in place, and replace the control cover.
4. Restore all power sources and cycle the equipment to check control operation.

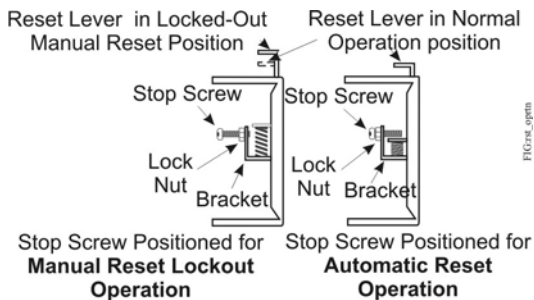

**Figure 10: Setting the Convertible High Pressure Reset Mechanism (P70S or P170S)**

## Low Pressure Limited Knob Adjustment

Some dual pressure controls are supplied with a Limited Knob Adjustment kit for the low pressure side (only) of the control. This restricts the adjustment of the low-side range and differential screws, and deters overadjustment or tampering with the control. A stop on the knob limits adjustment to less than one turn.

To install the Limited Knob Adjustment kit, see the following guidelines and steps.

1. To lock the differential adjustment screw and allow limited adjustment of the range screw, install the knob on the range screw.  
To lock the range screw and allow limited adjustment of the differential screw, install the knob on the differential screw.
2. Adjust control pointers to desired high event and low event setpoints (on All-Range controls), or differential setting (on MICRO-SET® controls).

3. Place the spacer on the desired adjustment screw. All-Range controls (with Limited Knob Adjustment kits) have round and knurled adjustment screws. The spacer must be placed on the range screw. MICRO-SET® controls have square adjustment screws. Always place the spacer on the same adjustment screw as the knob.
4. Align the large end of the indicator plate over the adjustment screw with spacer.
5. Align the small end of the indicator plate over the adjustment screw to be locked.
6. Align the knob over the large end of the indicator plate.
7. Attach the knob to the adjustment screw, and tighten the set screw.

**Note:** The Limited Knob Adjustment kit for the All-Range controls cannot be used with the MICRO-SET® controls (and vice-versa).

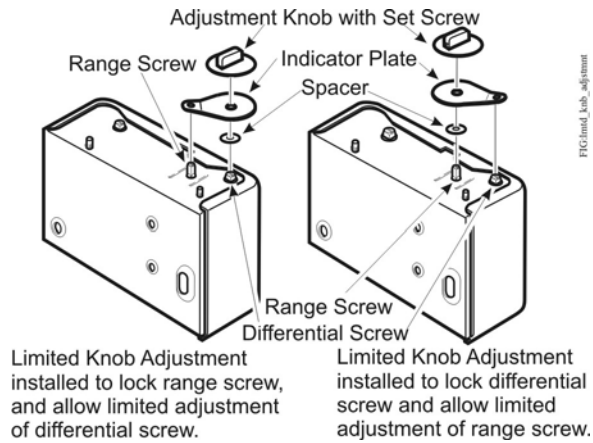

**Figure 11: Limited Knob Adjustment**

## Technical Specifications

**Table 4: SPST Electrical Ratings (P70L, M, N, and P170L, M, N Types)**

	Standard Single-Phase Ratings					Hermetic Compressor 1Ø Ratings
	120 VAC	208 VAC	240 VAC	480 VAC <sup>1</sup>	600 VAC <sup>1</sup>	208/240 VAC
<b>Motor Horsepower</b>	1.5	3	3	--	--	--
<b>Motor Full Load Amperes</b>	20	18.7	17	5	4.8	20
<b>Motor Locked Rotor Amperes</b>	120	112.2	102	30	28.8	120
<b>Non-Inductive Amperes</b>	22	22	22	--	--	--
<b>Pilot Duty</b>	125 VA at 120 to 600 VAC; 57.5 VA at 120 to 300 VDC					

1. Not for compressor motor loads.

**Table 5: 4-Wire 2-Circuit Electrical Ratings (P70P, Q, and R Types) (Part 1 of 2)**

	Standard Single-Phase Ratings									
	Line-M2 (Main Contacts)						Line-M1 (Auxiliary Contacts)			
	120 VAC	208 VAC	240 VAC	277 VAC	480 VAC <sup>1</sup>	600 VAC <sup>1</sup>	120 VAC	208 VAC	240 VAC	277 VAC
<b>Motor Full Load Amperes</b>	16.0	9.2	8.0	--	5	4.8	6.0	3.3	3.0	--
<b>Motor Locked Rotor Amperes</b>	96.0	55.2	48.0	--	30	28.8	36.0	19.8	18.0	--

**Table 5: 4-Wire 2-Circuit Electrical Ratings (P70P, Q, and R Types) (Part 2 of 2)**

<b>Non-Inductive Amperes</b>	16.0	9.2	8.0	7.2	--	--	6.0	6.0	6.0	6.0
<b>Pilot Duty (for both sets of contacts)</b>	125 VA at 24 to 600 VAC; 57.5 VA at 120 to 300 VDC									

1. Not for compressor motor loads.

**Table 6: SPDT Electrical Ratings (P70S and P170S Types, per switch)**

	<b>Standard Single-Phase Ratings</b>			
	<b>120 VAC</b>	<b>208 VAC</b>	<b>240 VAC</b>	<b>277 VAC</b>
<b>Motor Full Load Ampere</b>	16.0	9.2	8.0	7.0
<b>Motor Locked Rotor Ampere</b>	96.0	55.2	48.0	42.0
<b>Non-Inductive Ampere</b>	16.0	9.2	8.0	7.0
<b>Pilot Duty</b>	125 VA at 24 VAC, 720 VA at 120 to 277 VAC			

**Table 7: DPST Electrical Ratings (P72L, M, and N Types)**

	<b>Standard Ratings</b>							<b>Hermetic Compressor Ratings</b>	
	<b>120 VAC 1Ø</b>	<b>208 VAC 1Ø</b>	<b>240 VAC 1Ø</b>	<b>208 VAC 3Ø</b>	<b>220 VAC 3Ø</b>	<b>480 VAC 1Ø<sup>1</sup></b>	<b>600 VAC 1Ø<sup>1</sup></b>	<b>208 VAC 1Ø</b>	<b>240 VAC 1Ø</b>
<b>Motor Horsepower</b>	2	3	3	5	5	--	--	--	--
<b>Motor Full Load Amperes</b>	24	18.7	17	15.9	15	5	4.8	24	24
<b>Motor Locked Rotor Amperes</b>	144	112.2	102	95.4	90	30	28.8	144	144
<b>AC Non-Inductive Amperes</b>	24	24	24	24	24	--	--	--	--
<b>DC Non-Inductive Amperes</b>	3	0.5	0.5	0.5	0.5	--	--	--	--
<b>Pilot Duty</b>	125 VA at 120 to 600 VAC; 57.5 VA at 120 to 300 VDC								

1. Not for compressor motor loads

**P70, P72, and P170 Controls for Dual Pressure Applications (Part 1 of 2)**

<b>Switch Action</b>	P70, P170: SPST or 4-Wire, 2-Circuit P70S, P170S: Two independent SPDT PENN® switches P72: DPST
<b>Pressure Connection</b>	P70, P72 Standard Models: various connections available (Styles 5, 13, 15, 34, 37) P170 Standard Models 1/4 in. male flare hose connection (Style 5) P70LA-2, P70MA-2 Ammonia-Compatible Models 1/4 in. female NPT connection (Style 15)
<b>Maximum Overpressure (non-recurring)</b>	Low Side All-Range: 325 psig (2,241 kPa) Low Side MICRO-SET®: 525 psig (3,620 kPa) High Side (All-Range and MICRO-SET®): 525 psig (3,620 kPa)
<b>Maximum Working Pressure</b>	Low Side All-Range: 100 psig (690 kPa) Low Side MICRO-SET®: 80 psig (552 kPa) High Side (All-Range and MICRO-SET®): 500 psig (3,447 kPa)
<b>Ambient Conditions</b>	-40 to 140°F (-40 to 60°C)
<b>Case and Cover</b>	NEMA 1 Enclosures: Galvanized steel case, plated and painted steel cover NEMA 3R Enclosures: Plated and painted steel case and cover

**P70, P72, and P170 Controls for Dual Pressure Applications (Part 2 of 2 )**

<b>Dimensions (H x W x D)</b>	NEMA 1 Enclosure: 3-1/4 x 5-11/16 x 2-1/16 in. (83 x 144 x 53 mm) NEMA 3R Enclosure: 4-13/16 x 5-13/16 x 3-3/8 in. (122 x 148 x 86 mm)
<b>Approximate Shipping Weight</b>	NEMA 1 Enclosures Individual: 3.5 lb (1.6 kg) Bulk pack (25 controls): 75.5 lb (34.2 kg)
	NEMA3R Enclosures Individual: 4.7 lb (2.1 kg) Bulk pack (25 controls): 116.5 lb (52.9 kg)
<b>Agency Listings</b>	For information on specific models, contact Refrigeration Application Engineering at 1-800-275-5676.
<b>Accessories</b>	271-51 Universal Mounting Bracket (supplied with standard controls)

*The performance specifications are nominal and conform to acceptable industry standards. For application at conditions beyond these specifications, contact Refrigeration Application Engineering at 1-800-275-5676. Johnson Controls shall not be liable for damages resulting from misapplication or misuse of its products.*

**European Single Point of Contact:**

JOHNSON CONTROLS  
WESTENDHOF 3  
45143 ESSEN  
GERMANY

**NA/SA Single Point of Contact:**

JOHNSON CONTROLS  
507 E MICHIGAN ST  
MILWAUKEE WI 53202  
USA

**APAC Single Point of Contact:**

JOHNSON CONTROLS  
C/O CONTROLS PRODUCT MANAGEMENT  
NO. 22 BLOCK D NEW DISTRICT  
WUXI JIANGSU PROVINCE 214142  
CHINA



[www.penncontrols.com](http://www.penncontrols.com)

*® Johnson Controls and PENN are registered trademarks of Johnson Controls in the United States of America and/or other countries. All other trademarks used herein are the property of their respective owners. © Copyright 2018 by Johnson Controls. All rights reserved.*