



# DXMC Series (M-Style)

## EVAPORATOR COILS

### Specification Sheet

NOTE:  
NOT APPROVED FOR USE WITH  
HEAT PUMP SYSTEMS

The DXMC Series high-efficiency evaporator M-Coils provide an excellent option where low profile installations are required. The coils are applicable in up-flow or down-flow configurations. Each coil comes TXV ready with threaded equalizer port and liquid connection for simple field installation of OEM expansion valves. Multiple pistons sized for the nominal tonnage span of each coil are included for fixed orifice metering.

Features:

- R-22 or R-410A
- Bi-Directional Airflow
- Enhanced Aluminum Fins
- Rifled Copper Tubing

Pistons:

- The DXMC 1836 can use any of the following pistons .051 , .061, .067, .074.
- The DXMC 3048 can use any of the following pistons .067,.074, .080, .084.
- The DXMC 4260 can use any of the following pistons .080, .084, .093.

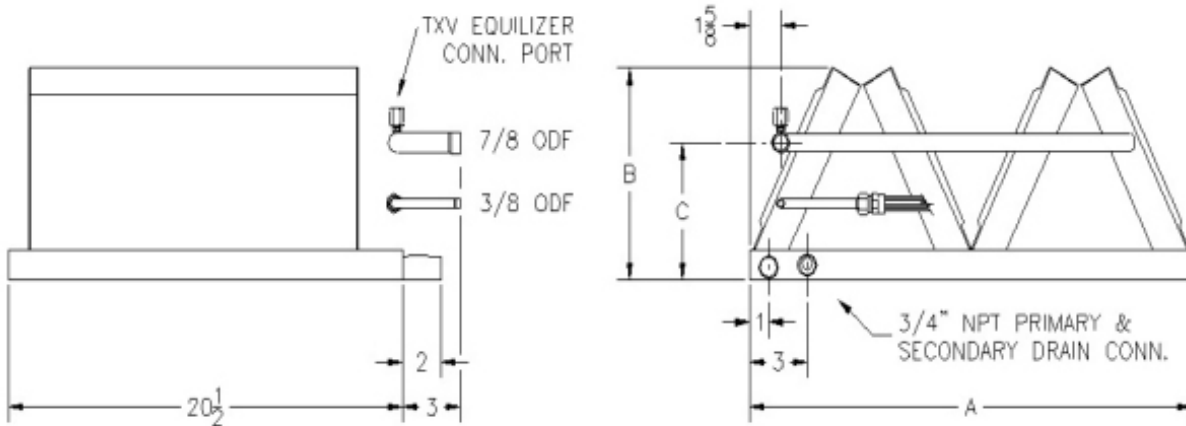

Model- DXMC	Face (ft <sup>2</sup> )	Coil Rows	A	B	C
1836	3.67	2	17"	8 1/4"	5"
3048	4.58	2	21"	10 1/8"	6 3/4"
4260	5.50	2	24"	12"	8 5/8"

## Capacities:

Model DXMC-	CFM	Air PD ("wg)	R-22 M BTU/HR		R-410A M BTU/HR	
			Total	Sensible	Total	Sensible
1836	600	0.11	27.6	18.4	29.7	19.6
	800	0.16	32.7	22.5	35.8	23.8
	1000	0.22	36.4	25.9	40.8	27.8
	1200	0.29	39.4	29.0	44.9	31.3
3048	1000	0.17	42.6	28.7	47.2	30.8
	1200	0.22	47.6	32.7	51.0	34.2
	1400	0.28	51.7	36.1	56.0	38.1
	1600	0.34	55.3	39.4	60.6	41.6
4260	1400	0.21	55.1	38.0	60.0	40.3
	1600	0.25	59.1	41.4	65.1	44.2
	1800	0.30	62.7	44.6	69.6	47.8
	2000	0.35	65.7	47.5	73.6	51.1

The DXMC Series may be used to replace coils outside of these capacities. For cooling only coils, select the model that most closely matches the face area and slab rows of the coil to be replaced. For heat-pump coils, the internal volume of the replacement coil must be within 3% of the coil to be replaced. The DXMC coil shall be metered to match the system condensing/heat-pump unit and charged accordingly.

Diversified Heat Transfer, Inc.  
439 Main Road, Rte. 202  
Towaco, NJ 07082

CONTACT US  
P. 718-386-6666 / 800-221-1522  
F. 718-386-7809  
E. dht@dhtnet.com

FOLLOW US @  
[facebook.com/diversifiedheattransfer](https://facebook.com/diversifiedheattransfer)  
[twitter.com/DiversifiedHeat](https://twitter.com/DiversifiedHeat)  
[linkedin.com/diversified-heat-transfer](https://linkedin.com/diversified-heat-transfer)

Scan Here

