

## General Information

- FAST-STAT wiring extenders electronically add more wires to a control cable.
- Saves significant time and expense as compared to re-pulling of new cables.
- Causes no damage to walls or ceilings as compared to access holes that are often needed when re-pulling cables.
- The Sender and Receiver communicate over the existing thermostat cable and/or outdoor unit cable.
- Not a wireless system and therefore avoids all the problems that wireless systems may have.
- No batteries required. All FAST-STAT models are powered by the existing 24 volt transformer.
- Compatible with all conventional wiring systems using R, C, W, W2, Y, Y2, G, O/B and other terminals.
- Works with old and new systems. Can be connected to older systems such as thermopile millivolt, standing pilot systems, intermittent pilot controllers, fan centers etc.
- Can be used with oil burners, zone controllers and other systems that require “dry contact switching”.
- Works over long cable lengths – up to 500 ft and more.
- FAST-STAT Wiring Extenders do not produce interference with other electronic devices nor are they affected electronic devices that produce large amounts of interference.
- Many FAST-STAT Wiring Extenders can be used in the same building or complex without interference between units.
- Low power use. Most FAST-STAT models use less than 3 watts of power.

# Model 5000

## Model 5000

- It adds four wires to a cable. For example, with a 2-wire cable, it can provide R, C, G, Y, W1 & W2 connections at a thermostat and indoor unit.
- With cables having more than two wires, the additional wires can be directly connected to the thermostat and indoor unit and used for any purpose.
- The Sender has eight wires; Power In "R", Power Out "R", a Communication wire, a Common wire, Input A, Input B, Input C & Input D.
- The Receiver has eight wires; Power In "R", Power Out "R", a Communication wire, Output A, Output B, Output C, Output D and a Common "C" wire.

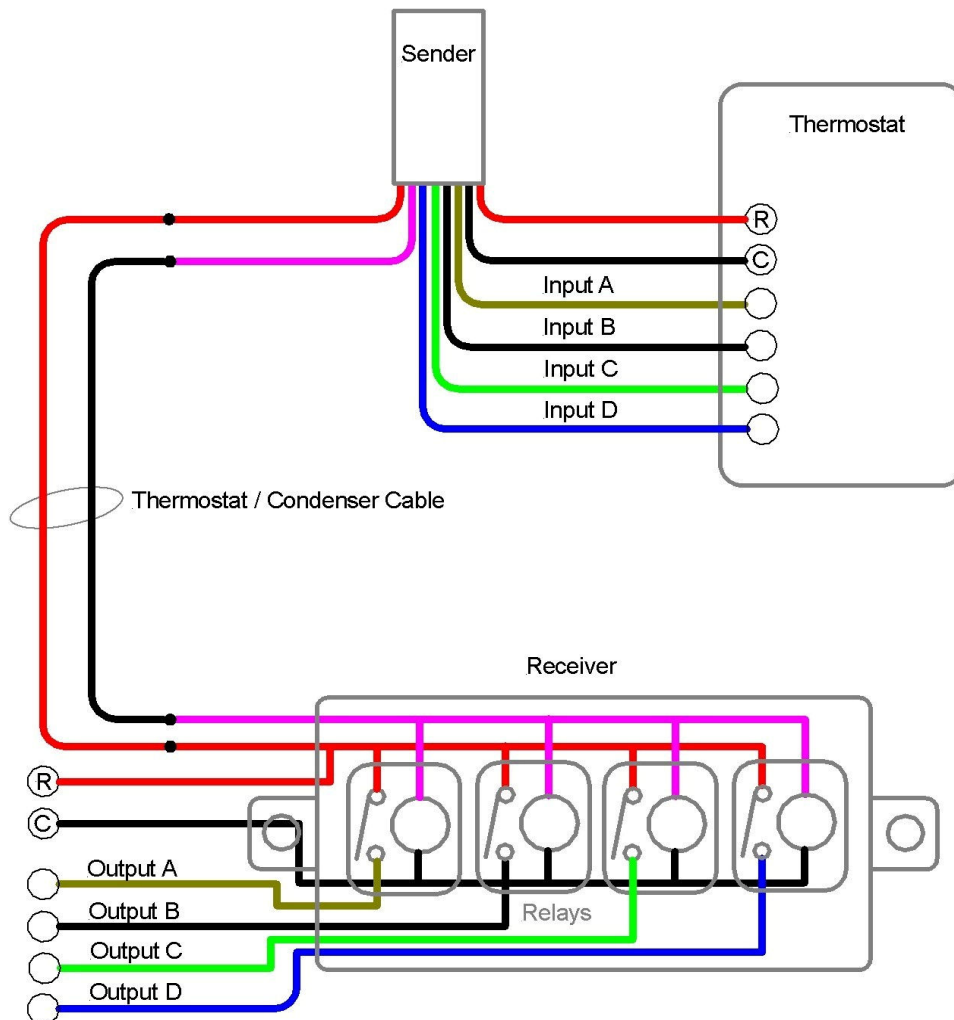

# Model 5000

## How It Works

Output A (GREEN wire) and output B (YELLOW wire) are linked so that when output B is on it will also switch on output A. For typical installations output A (GREEN wire) is used for “G” and output B (YELLOW wire) is used for “Y” so does not create any problems as the fan will be on with the when the air conditioner is running.

Output C (WHITE wire) and output D (BLUE wire) are linked so that when output D is on it will also switch on output C. For typical installations output C (WHITE wire) is used for “W1” and output D (BLUE wire) is used for “W2” so does not create any problems as heat stage-1 will be on when heat stage-2 is on.

When output C or output D is on, outputs A and B will shut off. If the fan is in “manual on” mode it will shut off the fan while the heat exchanger warms up and the furnace fan control/limit then switches on the fan. When the thermostat is in “fan manual on” mode, at the end of a heating cycle, the fan will continue to operate.

## Application Examples

### Adding Air Conditioning

A 2-wire thermostat cable can be converted to provide R, C, G, Y, W1 & W2 using the Model 5000. .

### Wi-Fi Thermostats

The Model 5000 can be used to add a common or “C” connection at the thermostat.

Many Wi-Fi thermostats have a self-configure option in which the thermostat automatically detects the wires connected to it in order to make easier for homeowners to install the thermostat. When using the Model 5000, do a “Reset” then select “Pro Setup” to manually configure the thermostat. There are diodes in the Model 5000 sender that often prevents the thermostat from properly auto-configuring itself.

### Adding an Extra Functions

The Model 5000 can be used to add W2, Y2, G, etc to a thermostat cable. For example the existing “W” wire can become W1, W2, G & Y.

### Cable Repairs

If a wire in a cable is broken (open circuit) or shorted to another wire or to ground, the Model 5000 can often be used to replace up to five damaged wires.

**Model 5000 used to extend wiring from a thermostat (2-wire cable)**  
**Example: 2-stage heat system and single-stage cooling**

DWG: 5K-A

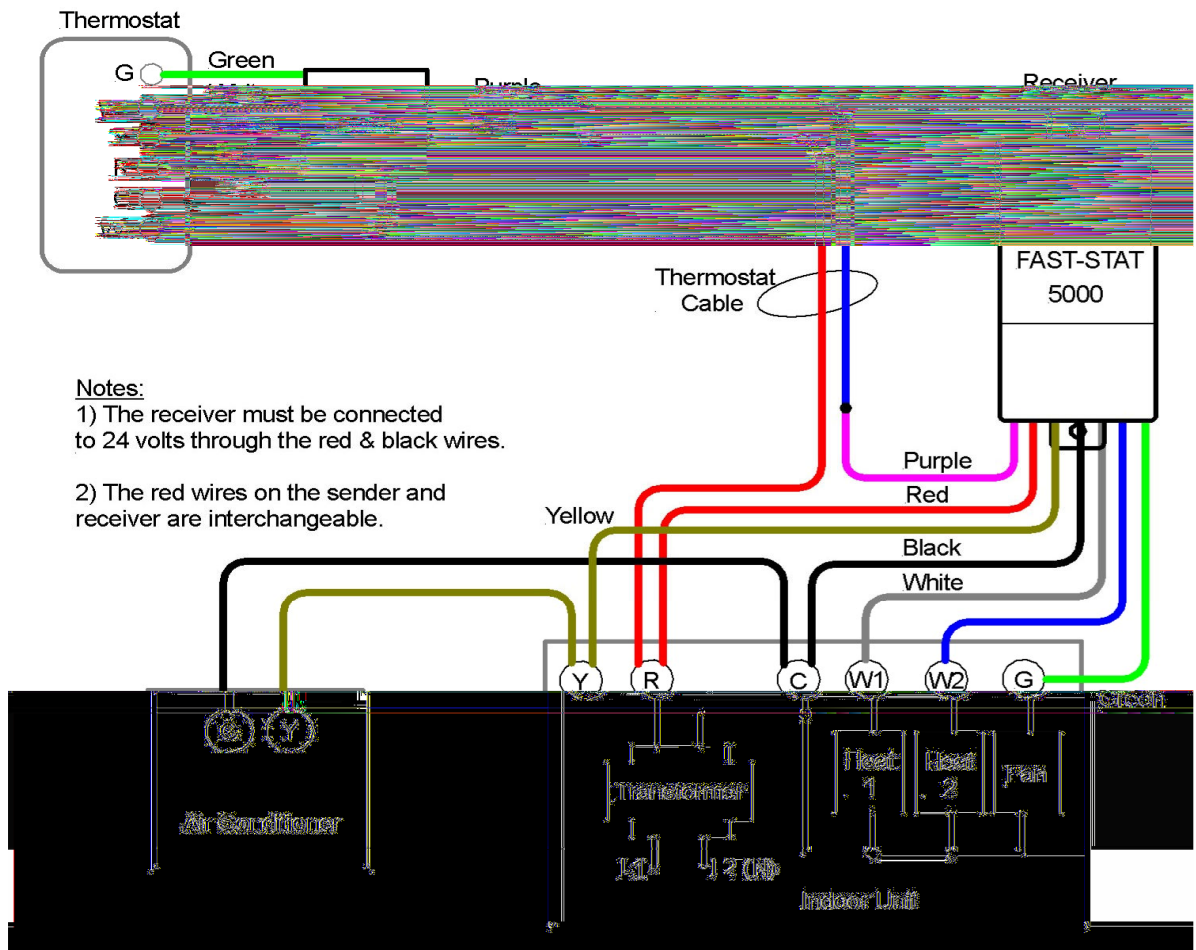

Model 5000 used to extend wiring from thermostat (more than 2 wires)

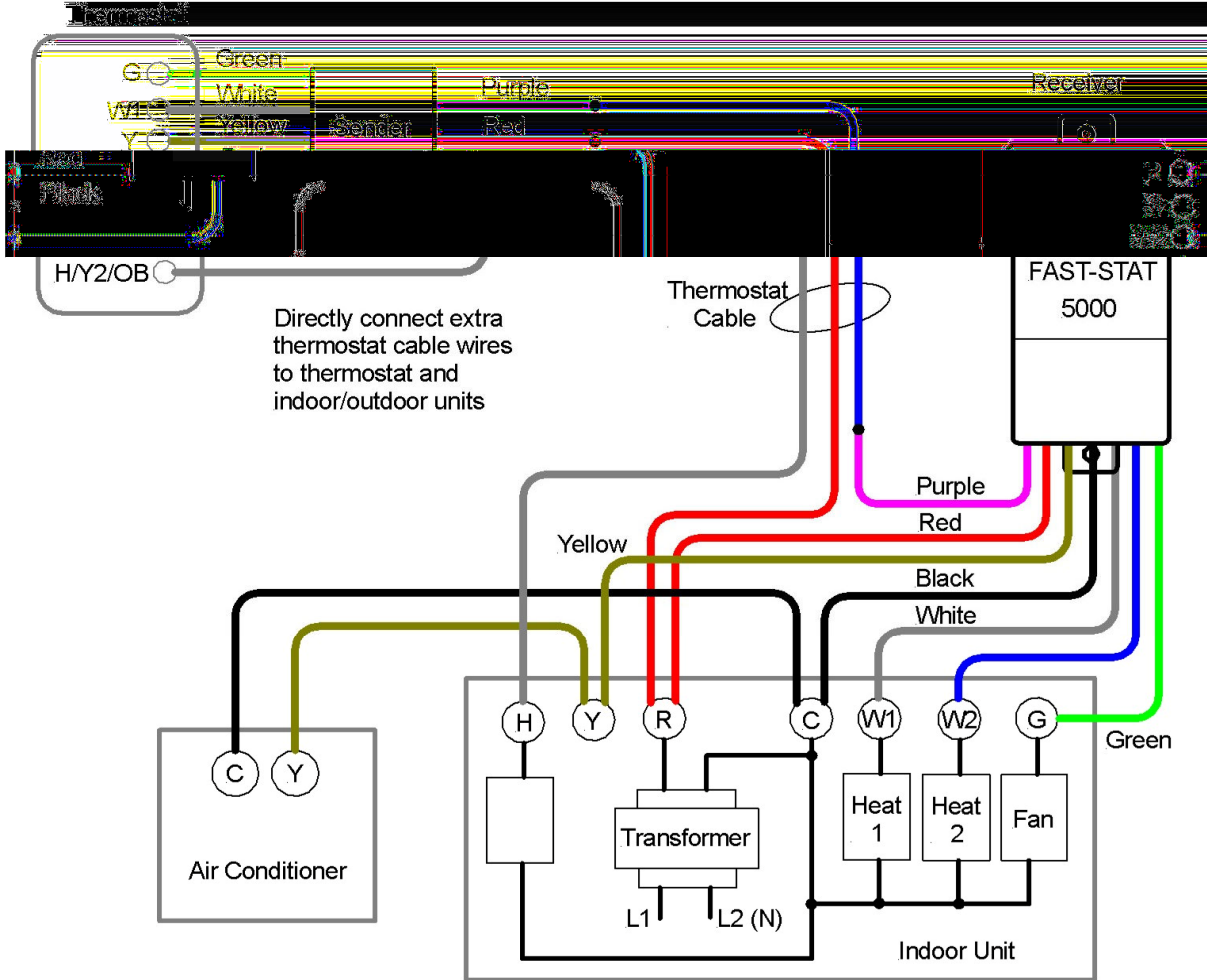

## Model 5000 Testing Method

1. Measure the transformer voltage (often marked as R and C). The meter should read from 24 to 28 volts AC. For furnaces, make sure the door switch is in the on position.
2. Connect the Sender directly to the Receiver: PURPLE to PURPLE & RED to RED and then connect the Receiver BLACK to transformer C, RED to transformer R.
3. Connect the Sender GREEN to the RED. The relay in the Receiver should switch on. With Sender GREEN still connected to the RED, measure the voltage between the Receiver GREEN wire and the transformer C. The meter should read 24 to 28 volts.
4. Connect the Sender GREEN & YELLOW to the RED. The relays in the Receiver should switch on. With Sender GREEN & YELLOW still connected to the transformer R, measure the voltage between the Receiver YELLOW wire and the transformer C. The meter should read 24 to 28 volts.
5. Connect the Sender WHITE to the RED. The relay in the Receiver should switch on. With Sender WHITE still connected to the RED, measure the voltage between the Receiver WHITE wire and the transformer C. The meter should read 24 to 28 volts.
6. Connect the Sender WHITE & BLUE to the RED. The relay in the Receiver should switch on. With Sender WHITE & BLUE still connected to the RED, measure the voltage between the Receiver BLUE wire and the transformer C. The meter should read 24 to 28 volts.

