

FHX072-120, FHS150-240 SPLIT SYSTEM HEAT PUMP, INDOOR UNIT (AIR-HANDLING) WITH R-410A REFRIGERANT, 6-20 TONS, 60 HZ, BUILT TO LAST, EASY TO INSTALL AND SERVICE

The FHX/FHS Series units with direct-expansion coils are the best choice for packaged heat pump air handlers. FHX units come with X-Vane Fan Technology. All models offer excellent fan performance, a unique combination of indoor air quality features, and easy installation. Their versatility and state-of-the-art features will provide economical performance. Easy-to-install and economical FHX/FHS units provide reliable service.

Our versatile packaged heat pump air-handling units satisfy design requirements with:

- Multi-position design for horizontal or vertical installation without modification.
- Standard sloped drain pans and cleanable insulation treated with an immobilized anti-microbial agent to inhibit the growth of bacteria and fungi on the insulation.
- High-static design meets a wider range of applications than competitive packaged air handler lines.
- Economizer accessory provides ventilation air and “free” cooling. Cooling coils with mechanically bonded fins provide peak heat transfer.
- Hot water coil, steam coil, and electric heat accessories are available.
- Standard factory-installed thermo-static expansion valves (TXV) with removable power element on FHX/FHS units.
- Die-formed galvanized steel casings provide durability and structural integrity. Optional paint is available.
- Upgraded unit control board with intuitive indoor fan adjustment.
- Standard 2-Speed Indoor Fan Motor system.

Easier installation and service

With the new X-Vane Axial fan system, there is no longer a need to adjust belts or pulleys as in past designs. This frees up maintenance and installation time.

The multi-position design and component layout allow for quick unit installation and operation. The DX coils have factory-installed TXVs with matching distributor nozzles. Units can be converted from horizontal to vertical operation by simply repositioning the unit.

There are simple, fast plug-in connections to the standard integrated unit control board (UCB). The UCB has clearly labeled connection points to reduce installation time. Also, a large control box provides room to work and mount accessory controls.

Drain pan connections are duplicated on both sides of the unit. The filters, motor, drive, TXVs, and coil connections are easily accessed by removing a single side panel.

The FHX units come with the new X-Vane vane axial fan system. With this system, there is no longer a need to adjust belts or pulleys as in past designs. This frees up maintenance and installation time.

Easy to use

Our newly re-designed Unit Control Board puts all connections and troubleshooting points in one convenient place. Most low voltage connections are made to the same board and make it easy to access it. Setting up the fan is simple by an intuitive switch and rotary dial arrangement.

X-Vane Technology (on FHX units)

Direct drive X-Vane Technology indoor fan system on FHX units uses Vane Axial fan design and electrically commutated motors on FHX units.

This new Vane Axial design over past belt drive systems has 75% fewer moving parts, uses up to 40% less energy and has no fan belts, blower bearings and shaft.

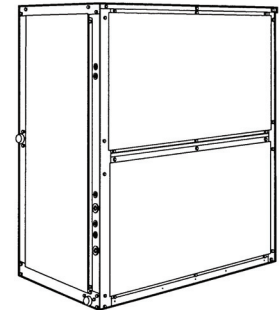

FHX072-120 unit shown

X-Vane Fan

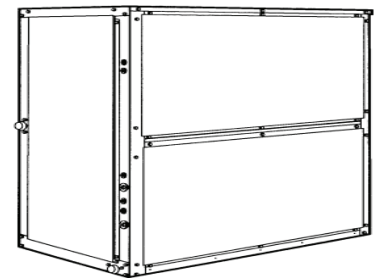

FHS180/240 unit shown

Table of contents

	PAGE		PAGE
FEATURES/BENEFITS	2	FAN DATA	23
MODEL NUMBER NOMENCLATURE	3	ELECTRICAL DATA	32
PHYSICAL DATA	5	TYPICAL PIPING AND WIRING DIAGRAMS	38
OPTIONS AND ACCESSORIES	9	APPLICATION DATA	42
BASE UNIT DIMENSIONS	11	GUIDE SPECIFICATIONS — FHX	43
ACCESSORY DIMENSIONS	15	GUIDE SPECIFICATIONS — FHS	46
PERFORMANCE DATA	20		

Features/Benefits

Indoor air quality

The unique combination of features in the FHX/FHS Series air handlers ensures that clean, fresh, conditioned air is delivered to the occupied space.

Cooling coils prevent the build-up of humidity in the room, even during part-load conditions.

2 in. (51 mm) disposable filters remove dust and airborne particles from the occupied space.

Pitched drain pan can be adjusted for a right-hand or left-hand connection to provide positive drainage and prevent standing condensate. Each unit contains two separate drain pans which are provided for either vertical or horizontal fan coil positions.

Accessory economizer can provide ventilation air to improve indoor air quality. When used with CO₂ sensors, the economizer admits fresh outdoor air to replace stale, recirculated indoor air.

Economy

The FHX/FHS Series packaged air handlers have low initial costs, and they continue to save money by providing reduced installation expense and energy-efficient performance.

Quick installation is ensured by the multi-position design. Units can be installed in either the horizontal or vertical (upflow) configuration without modifications. All units have drain-pan connections on both sides, and pans can be pitched for right-hand or left hand operation with a simple adjustment.

Fan motors and contactors are pre-wired and TXVs are factory-installed on FHX/FHS models.

High-efficiency, precision balanced fans minimize air turbulence, surging, and unbalanced operation, thereby cutting operating expenses.

Economizer accessory precisely controls the blend of outdoor air and room air to achieve comfort levels. When the outside air enthalpy is suitable, outside air dampers can fully open to provide “free” cooling.

Rugged dependability

Die-formed galvanized steel panels ensure structural integrity under all operating conditions. Mechanically bonded coil fins provide improved heat transfer. For FHS units, galvanized steel fan housings are securely mounted to a die-formed galvanized steel deck. Model FHX/FHS air handling units have galvanized steel casings; inlet and outlet connections are on the same end.

Direct expansion (DX) coils are designed for use with R-410A refrigerant and have copper tubes mechanically bonded to aluminum sine-wave fins. Direct-expansion coils include matched, factory-installed thermostatic expansion valves (TXVs) with matching distributor nozzles.

This air handling unit has thermal insulation containing an immobilized anti-microbial agent to inhibit the growth of bacteria and fungi on the insulation.

2-Speed Indoor Fan Motor system

Our 2-Speed Indoor Fan Motor system units will automatically adjust the indoor fan motor speed in sequence with the unit's cooling operation. Per ASHRAE 90.1 2010 standard section 6.4.3.10.b, during the first stage of cooling operation the fan motor (either ECM or controlled by VFD) will adjust to provide two-thirds of the total cfm established for the unit. When a call for the second stage of cooling is required, the fan motor will allow the total cfm (100%) established for the unit. During the heating mode the fan motor will allow total design cfm (100%) operation and during the ventilation mode the fan motor will allow operation to two-thirds of total cfm.

Model number nomenclature

FHX Model Number Nomenclature

MODEL SERIES	F	H	X	0	9	1	H	2	A	A	0	A	U	A		
Position Number	1	2	3	4	5	6	7	8	9	10	11	12	13	14		
F = R-410A Fan Coil Unit																
H = Heat Pump																
		Type														
X = X-Vane Vane Axial Fan (VAF)																
		Efficiency														
072 = 6 Tons (1 circuit)				091 = 7.5 Tons (1 circuit)				120 = 10 Tons (2 circuit)								
				Nominal Tonnage												
H = 208/230-3-60		L = 460-3-60		S = 575-3-60										Voltage ¹		
2 = Standard Efficiency / Medium Static Motor		3 = Standard Efficiency / High Static Motor												Fan Motor Options		
A = Al/Cu														Coil Options		
A = Heat Pump Coil														Type of Coil		
0 = X-Vane Two-Speed Fan														Fan Motor Speed Controller		
A = Standard — Unpainted								B = Painted Cabinet							Painted Cabinet Options	
U = Unit Control Board (UCB) Electromechanical Controls												Controls				
A = Standard													Packaging			

¹ There are no multi-voltage units with the 2-Speed Vane Axial Fan (VAF), as the motors are dedicated voltage.

Model number nomenclature (cont)

FHS Model Number Nomenclature

MODEL SERIES	F	H	S	1	8	0	H	A	A	A	2	A	U	A
Position Number	1	2	3	4	5	6	7	8	9	10	11	12	13	14
F = R-410A Fan Coil Unit	Type													
H = Heat Pump	Efficiency													
S = Standard Efficiency	Nominal Tonnage													
180 = 15 Tons (2 circuit) 240 = 20 Tons (2 circuit)	Voltage ¹													
H = 208/230-3-60 L = 460-3-60 S = 575-3-60	Fan Motor Options													
A = Standard Static Standard Efficiency Motor / Standard Drive (size 180) Standard Static High Efficiency Motor / Standard Drive (size 240) B = High (Alternate) Static High Efficiency Motor / High Drive	Indoor Coil													
A = Al/Cu	Coil Type													
A = Heat Pump Coil	Indoor Fan Speed Controller													
2 = Two Speed Fan Controller (VFD)	Painted Cabinet Options													
A = None (unpainted) B = Painted cabinet	Controls													
U = Electromechanical Unit Control Board	Packaging													
A = Standard														

¹ There are no multi-voltage units with the optional 2-speed indoor fan motor / VFD controller. VFD controllers are dedicated voltage devices for 208/230v, 460v, and 575v.

FHX — 2-Speed Motors

POSITION 8	MOTOR DESCRIPTION	VOLTAGE	UNIT SIZE		
			072	091	120
2	Standard/Medium Static (X-Vane)	All	X	X	X
3	High Static (X-Vane)	All	X	X	X

FHS — 2-Speed Motors

POSITION 8	MOTOR DESCRIPTION	VOLTAGE	UNIT SIZE	
			180	240
A	Std Efficiency Motor / Standard Static	All	X	—
A	High Efficiency Motor / Standard Static	All	—	X
B	High Efficiency Motor / High Static	All	X	X

Physical data

FHX072-120 Ton Heat Pump Units

UNIT FHX	072	091	120
NOMINAL CAPACITY (Tons)	6	7-1/2	10
OPERATING WEIGHT (lb)			
Base Unit with TXV	381	385	427
Plenum	175	175	175
FANS			
Qty...Diam. (in.)	1...23	1...23	1...23
Nominal Airflow (cfm)	2400	2625	3000
Airflow Range (cfm)	1800-3000	2250-3750	3000-5000
Nominal Motor Hp (Standard Motor)			
208/230-3-60 and 460-3-60	2.4	2.4	2.4
575-3-60	2.4	2.4	2.4
Motor Speed (rpm)			
208/230-3-60 and 460-3-60	2000	2000	2000
575-3-60	2000	2000	2000
REFRIGERANT	R-410A	R-410A	R-410A
Operating Charge (lb) (approx per circuit) ^a	3.0	3.0	2.0/2.0
DIRECT-EXPANSION COIL			
Max Working Pressure (psig)	650	650	650
Face Area (sq ft)	8.33	8.33	10.0
No. of Splits	1	1	2
No. of Circuits per Split	12	12	9
Split Type...Percentage	Face...100	Face...100	Face...50/50
Rows...Fins/in.	4...15	4...15	4...15
PIPING CONNECTIONS			
Quantity...Size (in.)			
DX Coil — Suction (ODF)	1...1-1/8	1...1-1/8	2...1-1/8
DX Coil — Liquid Refrigerant (ODF)	1...5/8	1...5/8	2...5/8
Steam Coil, In (MPT)	1...2-1/2	1...2-1/2	1...2-1/2
Steam Coil, Out (MPT)	1...1-1/2	1...1-1/2	1...1-1/2
Hot Water Coil, In (MPT)	1...1-1/2	1...1-1/2	1...1-1/2
Hot Water Coil, Out (MPT)	1...1-1/2	1...1-1/2	1...1-1/2
Condensate (PVC)	1...5/8 ODM / 1-1/4 IDF	1...5/8 ODM / 1-1/4 IDF	1...5/8 ODM / 1-1/4 IDF
FILTERS			
Quantity...Size (in.)	4...16 x 24 x 2	4...16 x 24 x 2	4...16 x 24 x 2
Access Location	Either Side	Either Side	Either Side
STEAM COIL^b			
Max Working Pressure (psig at 260°F)	20	20	20
Total Face Area (sq ft)	6.67	6.67	6.67
Rows...Fins/in.	1...9	1...9	1...9
HOT WATER COIL^b			
Max Working Pressure (psig)	150	150	150
Total Face Area (sq ft)	6.67	6.67	6.67
Rows...Fins/in.	2...8.5	2...8.5	2...8.5
Water Volume			
(gal)	8.3	8.3	8.3
(ft ³)	1.1	1.1	1.1

NOTE(S):

- a. Units are shipped without refrigerant charge.
b. Field installed accessory only.

LEGEND

- DX** — Direct Expansion
IDF — Inside Diameter, Female
ODF — Outside Diameter, Female
ODM — Outside Diameter, Male
TXV — Thermostatic Expansion Valve

Physical data (cont)

FHS180/240 Physical Data, English — Heat Pump Units

UNIT FHS	180	240
NOMINAL CAPACITY (tons)	15	20
OPERATING WEIGHT (lb)		
Base Unit with TXV	713	720
Plenum	225	225
FANS		
Qty...Diam. (in.)	2...15	2...15
Nominal Airflow (cfm)	5625	8,000
Airflow Range (cfm)	4500-7500	6,000-10,000
Nominal Motor Hp (Standard Motor)		
208/230-3-60 and 460-3-60	3.7	5.0
575-3-60	3.0	5.0
Motor Speed (rpm)		
208/230-3-60 and 460-3-60	1725	1760
575-3-60	1725	1745
REFRIGERANT		R-410A
Operating Charge (lb) (approx per circuit) ^a	3.0/3.0	3.5/3.5
DIRECT EXPANSION COIL	Enhanced Copper Tubes, Aluminum Sine-Wave Fins	Enhanced Copper Tubes, Aluminum Sine-Wave Fins
Max Working Pressure (psig)	650	650
Face Area (sq ft)	16.56	19.9
No. of Splits	2	2
No. of Circuits per Split	10	10
Split Type...Percentage	Face...50/50	Face...50/50
Rows...Fins/in.	4...15	4...15
PIPING CONNECTIONS		
Quantity...Size (in.)		
DX Coil — Suction (ODF)	2...1-1/8	2...1-1/8
DX Coil — Liquid Refrigerant (ODF)	2...5/8	2...5/8
Steam Coil, In (MPT)	1...2-1/2	1...2-1/2
Steam Coil, Out (MPT)	1...1-1/2	1...1-1/2
Hot Water Coil, In (MPT)	1...2	1...2
Hot Water Coil, Out (MPT)	1...2	1...2
Condensate (PVC)	1...1-5/8 ODM / 1-1/4 IDF	1...1-1/4 ODM/1 IDF
FILTERS	Throwaway — Factory Supplied	Throwaway — Factory Supplied
Quantity...Size (in.)	4...16 x 20 x 2 4...16 x 24 x 2	4...16 x 20 x 2 4...16 x 24 x 2
Access Location	Either Side	Right or Left Side
STEAM COIL^b		
Max Working Pressure (psig at 260°F)	20	20
Total Face Area (sq ft)	13.33	13.33
Rows...Fins/in.	1...10	1...10
HOT WATER COIL^b		
Max Working Pressure (psig)	150	150
Total Face Area (sq ft)	13.33	13.33
Rows...Fins/in.	2...8.5	2...8.5
Water Volume		
(gal)	13.9	13.9
(ft ³)	1.85	1.85

NOTE(S):

- a. Units are shipped without refrigerant charge.
- b. Field-installed accessory only.

LEGEND

- DX** — Direct Expansion
- IDF** — Inside Diameter, Female
- ODF** — Outside Diameter, Female
- ODM** — Outside Diameter, Male
- TXV** — Thermostatic Expansion Valve

Physical data (cont)

FHX Fan Motor Data Standard Motor — 2-Speed

UNIT	FHX072	FHX091	FHX120
208/230-3-60, 460-3-60, and 575-3-60			
Speed (rpm)	2000	2000	2000
Hp	2.4	2.4	2.4

FHX Motor Efficiency — Direct Drive 2-Speed Motor

MOTOR Hp	EPACT MINIMUM	MOTOR EFFICIENCY
2.4	—	85.0%
3.0	—	85.0%

WEIGHTS	MEDIUM	HIGH
Motor Hp	2.4	3.0
Motor Weight (lb)	23.8	53.7
Assembly Weight (lb)	56.4	85.6

LEGEND

EPACT — Energy Policy and Conservation Act of 1992
 NEMA — National Electrical Manufacturers Association (U.S.A.)

FHS Fan Motor Data Standard Motor — 2-Speed

UNIT	FHS180	FHS240
208/230-3-60 and 460-3-60		
Speed (rpm)	1750	1755
Hp	3.7	5.0
Frame (NEMA)	56HY	184T
Shaft Dia (in.)	7/8	1-1/8
575-3-60		
Speed (rpm)	1710	1755
Hp	3.7	5.0
Frame (NEMA)	56HY	184T
Shaft Dia (in.)	7/8	1-1/8

FHS Fan Motor Data Alternate Motor — 2-Speed

UNIT	FHS180	FHS240
208/230-3-60 and 460-3-60		
Speed (rpm)	1755	1760
Hp	5.0	7.5
Frame (NEMA)	184T	S213T
Shaft Dia (in.)	1-1/8	1-3/8
575-3-60		
Speed (rpm)	1755	1750
Hp	5.0	7.5
Frame (NEMA)	184T	S213T
Shaft Dia (in.)	1-1/8	1-3/8

FHS Motor Efficiency — 2-Speed Motor

MOTOR Hp	EPACT MINIMUM	MOTOR EFFICIENCY
3.7	—	83.6%
5.0	89.5%	89.5%
7.5	91.7%	91.7%

LEGEND

EPACT — Energy Policy and Conservation Act of 1992
 NEMA — National Electrical Manufacturers Association (U.S.A.)

Physical data (cont)

Standard Static Drive Data

UNIT	FHS180	FHS240
MOTOR DRIVE		
Motor Pulley Pitch Dia (in.)	2.8-3.8	3.7-4.7
Pulley Factory Setting Full Turns Open	2.5	3.0
FAN DRIVE		
Pulley Pitch Dia (in.)	9.0	9.4
Pulley Bore (in.)	1-7/16	1-7/16
Belt No. — Section	1—A	1—B
Belt Pitch (in.)	42.3	41.8
FAN SPEEDS (rpm)		
Factory Settings	632	771
Range	537-728	679-863
Max Allowable Speed (rpm)	1200	1200
Change per 1/2 turn of Movable Motor Pulley Flange	19.1	15.3
MAX FULL TURNS FROM CLOSED POSITION	5	6
SHAFTS CENTER DISTANCE (in.)	10.44 -12.32	9.12 -10.99

High-Static Drive Data

UNIT	FHS180	FHS240
MOTOR DRIVE		
Motor Pulley Pitch Dia (in.)	4.3-5.3	4.3-5.3
Pulley Factory Setting Full Turns Open	3.0	3.0
FAN DRIVE		
Pulley Pitch Dia (in.)	7.9	7.4
Pulley Bore (in.)	1-7/16	1-7/16
Belt No. — Section	1—B	2—B
Belt Pitch (in.)	39.8	36.8
FAN SPEEDS (rpm)		
Factory Setting	1060	1118
Range	950-1171	1014-1200 ^a
Max Allowable Speed (rpm)	1200	1200
Change per 1/2 Turn of Movable Motor Pulley Flange	18.4	19.4
MAX FULL TURNS FROM CLOSED POSITION	6	6
SHAFTS CENTER DISTANCE (in.)	9.16-10.99	8.16-10.02

NOTE(S):

a. It is possible to adjust drive so that fan speed exceeds maximum allowable. DO NOT exceed 1200 rpm.

Options and accessories

ITEM	FACTORY-INSTALLED OPTION	FIELD-INSTALLED ACCESSORY
Alternate Fan Motor	X	
Alternate Drive	X	
CO ₂ Sensors		X
Condensate Drain Trap		X
Discharge Duct Adapter (FHX only)		X
Discharge Plenum		X
EconoMi\$er X, Ultra Low Leak — FDD		X
EconoMi\$er IV, Standard Leak		X
Electric Heater		X
Hot Water Heating Coils		X
Optional Display Kit for 2-Speed Indoor Fan Motor with VFD (FHS only)		X
Overhead Suspension Package		X
Pre-Painted Units	X	
Return Air Grille		X
Steam Heating Coil		X

Factory-installed options

Alternate fan motors and drives

Alternate fan motor drives are available to provide the widest possible range of performance.

Pre-painted steel units

Pre-painted steel units are available from the factory for applications that require painted units. Units are painted with American Sterling Gray color.

Field-installed accessories

Optional VFD display kit (FHS only)

There is an optional VFD display kit offered (as an accessory) to allow the user to troubleshoot any VFD faults in the field after startup.

NOTE: Do not use the VFD display kit to adjust the frequency and voltage in the VFD to required performance requirements. This could lead to decreased life of the motor and VFD.

CO₂ sensors

CO₂ sensors can be used in conjunction with the economizer accessory to help meet indoor air quality requirements. The sensor signals the economizer to open when the CO₂ level in the space exceeds the set point. A field-supplied programmable thermostat can be used to override the sensor if the outside-air temperature is too high or too low.

Condensate drain trap

The condensate drain trap includes an overflow shutoff switch that can be wired to turn off the unit if the trap becomes plugged. The kit also includes a wire harness that can be connected to an alarm if desired. The transparent trap is designed for easy service and maintenance.

Discharge plenum

The discharge plenum directs the air discharge directly into the occupied space; integral horizontal and vertical louvers enable redirection of airflow. This accessory is available unpainted or painted. Field assembly is required (only applicable for vertical application).

Economizers — temperature dry bulb controlled

The Ultra Low Leak — EconoMi\$er X

This economizer accessory comes with solid-state W7220 controller, gear-driven, modulating damper, and spring return actuator. This economizer is supply and outdoor air sensors, and CO₂ sensor compatible, for use in electromechanical controls only. It Also includes return and outside air damper leakage that meets California Title 24 section 140.4 requirements. Controller meets California Title 24 Section 120.2 Fault Detection and Diagnostic (FDD) requirements.

Standard — EconoMi\$er IV

The standard economizer accessory comes with gear driven damper blades and W7212 controller. (Use p/n 1176668 sensor for enthalpy control).

Electric heater

Electric heaters are available as factory-supplied, field-installed accessories for nominal 240v, 480v, and 575v, 3-phase, 60 Hz units. Electric heaters are ETL (U.S.A.) and ETL, Canada, agency-approved. They have single-point power wiring. The heater assembly includes contactors with 24-v coils, power wiring, 24v control wiring terminal blocks, and a hinged access panel. Electric heaters should not be used with an air discharge plenum.

Two-row hot water coils

Two-row hot water coils have copper tubes mechanically bonded to aluminum plate fins and non-ferrous headers.

Overhead suspension package

The overhead suspension package includes necessary brackets to support units in horizontal ceiling installations.

Return-air grille

The return-air grille provides a protective barrier over the return-air opening and gives a finished appearance to units installed in the occupied space. This accessory is available unpainted or painted.

Options and accessories (cont)

One-row steam coil

The one-row steam coil has copper tubes and aluminum fins. The Inner Distributing Tube (IDT) design provides uniform temperatures across the coil face. The steam coil has a broad operating pressure range; up to 20 psi (138 kPag) at 260°F (126°C). The IDT steam coils are

especially suited to applications where sub-freezing air enters the unit.

Discharge duct adapter

This accessory is required for replacements using FHX units with or without electric heat. It is not required for new installations or when using steam coil, hot water coil, or discharge plenum accessories.

FHX072-120

UNIT	UNIT WEIGHT (W/TXV)
FAX072	399 lbs [181 kg]
FAX090	404 lbs [183 kg]
FAX120	425 lbs [193 kg]
FHX072	381 lbs [173 kg]
FHX090	385 lbs [175 kg]
FHX120	427 lbs [194 kg]



THIS DOCUMENT IS THE PROPERTY OF CARRIER CORPORATION AND IS DELIVERED UPON THE EXPRESS CONDITION THAT THE CONTENTS WILL NOT BE DISCLOSED OR USED WITHOUT WRITTEN CONSENT.

SUBMISSION OF THESE DRAWINGS OR DOCUMENTS DOES NOT CONSTITUTE PART PERFORMANCE OR ACCEPTANCE OF CONTRACT.

- NOTES:
1. DIMENSIONS IN [] ARE IN MILLIMETERS.
 2. DIRECTIONS OF AIRFLOW.
 3. RECOMMENDED CLEARANCE:
 REAR: 2 ft 6 in. [762 mm]
 FRONT: 2 ft 6 in. [762 mm]
 RIGHT SIDE: 2 ft 6 in. [762 mm]
 LEFT SIDE: 2 ft 6 in. [762 mm]
 LOCAL CODES OR JURISDICTION MAY PREVAIL.
 4. LIQUID PIPING NOT SUPPLIED BY CARRIER.
 5. DUCT FLANGE IS FACTORY SUPPLIED AND FIELD INSTALLED.

ACCESSORY	SEE DRAWING
DISCHARGE PLENUM	40RM500996
ECONOMIZER	40RM500999
STEAM COIL	40RM500999
HOT WATER COIL	40RM500999
RETURN AIR GRILLE	40RM500996
OVERHEAD SUSPENSION	40RM500996
SUBBASE	40RM500996

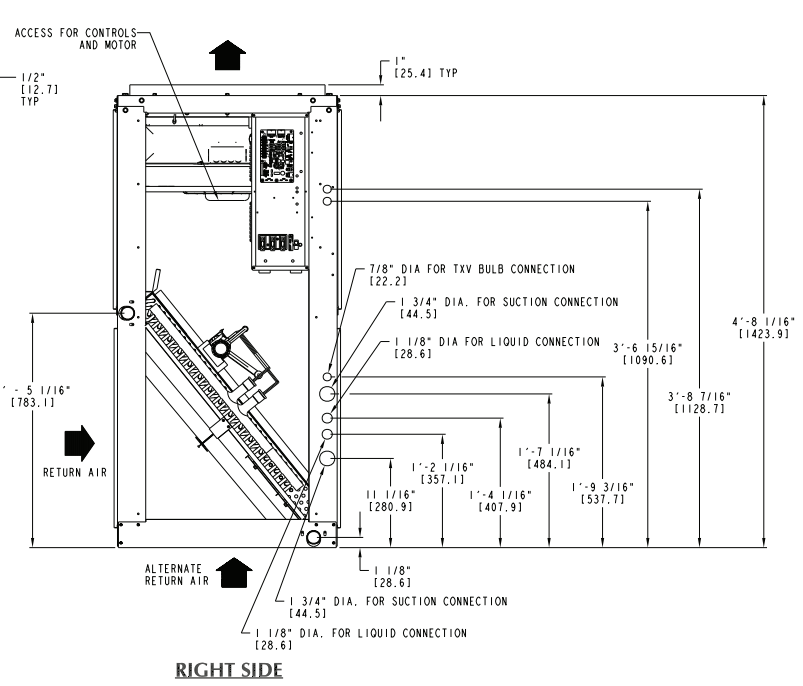
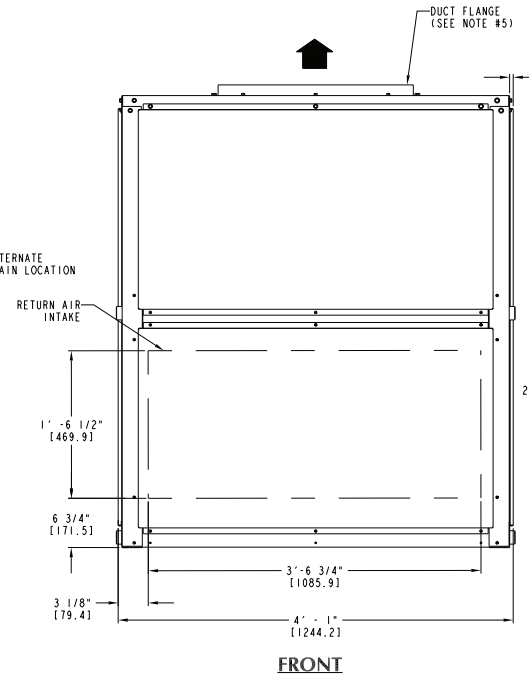
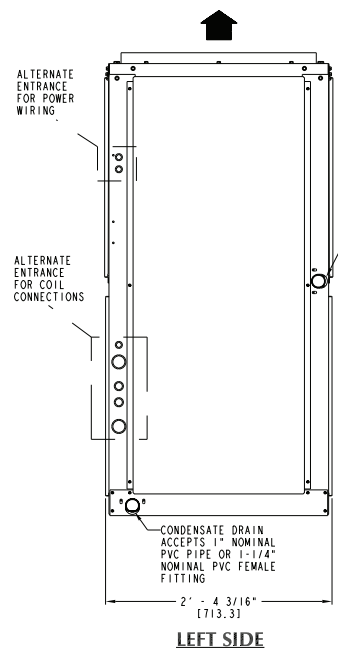
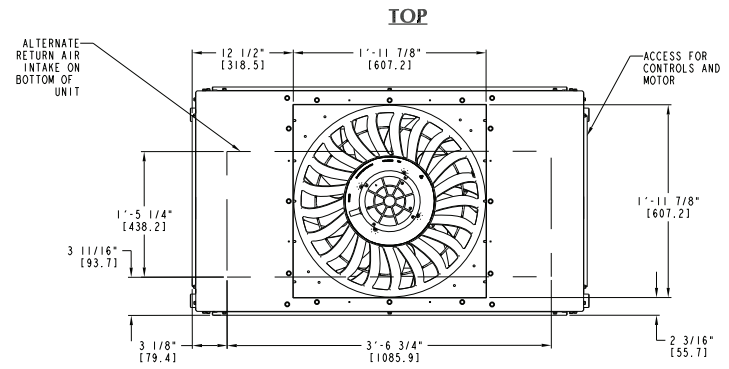

ITC CLASSIFICATION	SHEET	DATE	SUPERCEDES	FAN COIL UNITS	40RU000675	REV
U.S. ECCN: NSR	1 OF 2	10/31/22	-	FAX / FHX -072 / 090 / 120		-

NOTE: Dimensions and drawings for FHX090 also apply to FHX091.

FHS150-240



THIS DOCUMENT IS THE PROPERTY OF CARRIER CORPORATION AND IS DELIVERED UPON THE EXPRESS CONDITION THAT THE CONTENTS WILL NOT BE DISCLOSED OR USED WITHOUT WRITTEN CONSENT.

SUBMISSION OF THESE DRAWINGS OR DOCUMENTS DOES NOT CONSTITUTE PART PERFORMANCE OR ACCEPTANCE OF CONTRACT.

UNIT	UNIT WEIGHT (W/TXV)
FAS150	695 lbs [316 kg]
FAS180	713 lbs [323 kg]
FAS240	730 lbs [332 kg]
FHS180	713 lbs [323 kg]
FHS240	720 lbs [327 kg]

TOP

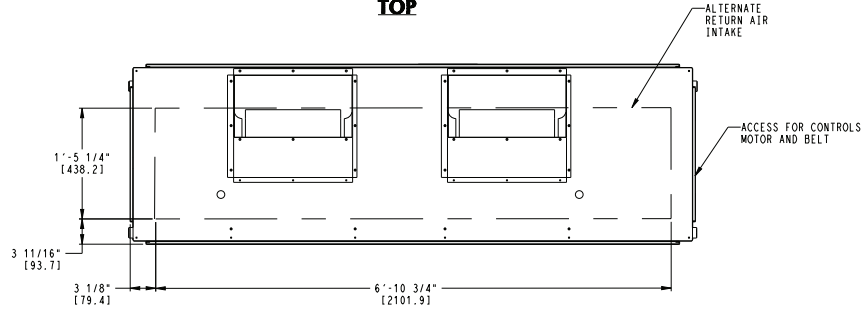

- NOTES:
1. DIMENSIONS IN [] ARE IN MILLIMETERS.
 2. DIRECTIONS OF AIRFLOW.
 3. RECOMMENDED CLEARANCE:
 REAR: 2 ft 6 in. [762 mm]
 FRONT: 2 ft 6 in. [762 mm]
 RIGHT SIDE: 2 ft 6 in. [762 mm]
 LEFT SIDE: 2 ft 6 in. [762 mm]
 LOCAL CODES OR JURISDICTION MAY PREVAIL.
 LIQUID PIPING NOT SUPPLIED BY CARRIER.
 4. LIQUID PIPING NOT SUPPLIED BY CARRIER.
 5. DUCT FLANGE IS FACTORY SUPPLIED AND FIELD INSTALLED.

ACCESSORY	SEE DRAWING
DISCHARGE PLENUM	40RMS00997
ECONOMIZER	40RMS01000
STEAM COIL	40RMS01000
HOT WATER COIL	40RMS01000
RETURN AIR GRILLE	40RMS00997
OVERHEAD SUSPENSION	40RMS00997
SUBBASE	40RMS00997
ELECTRIC HEAT	40RMS01002

UNRELEASED DATA

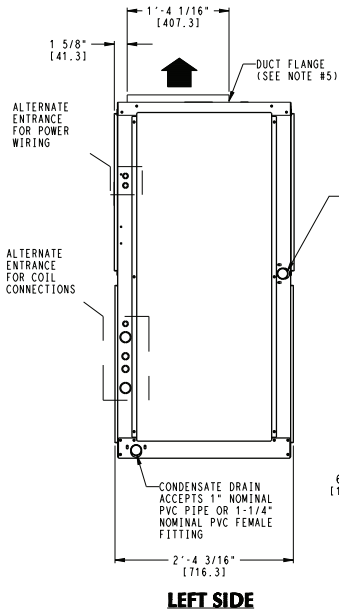

LEFT SIDE

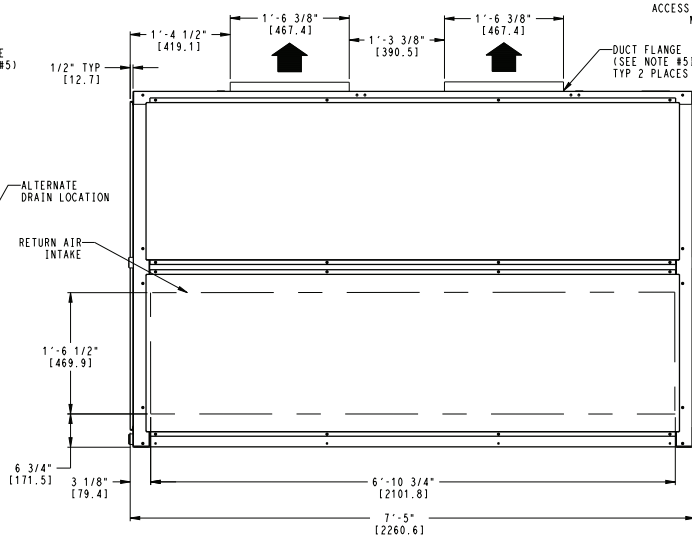

FRONT

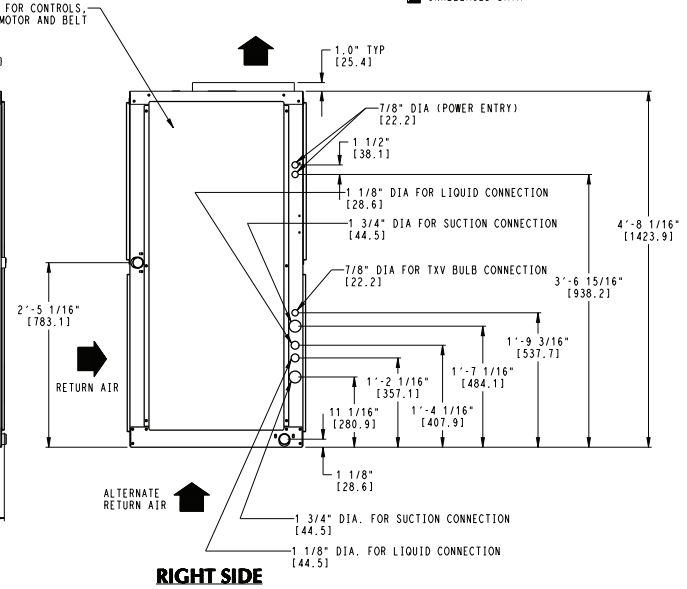

RIGHT SIDE

ITC CLASSIFICATION	SHEET	DATE	SUPERCEDES	FAN COIL UNITS	40RU500100	REV
U.S. ECCN:NSR	1 OF 2	07/14/21	03/16/18	FAS / FHS - 150 / 180 / 240		E

Base unit dimensions (cont)

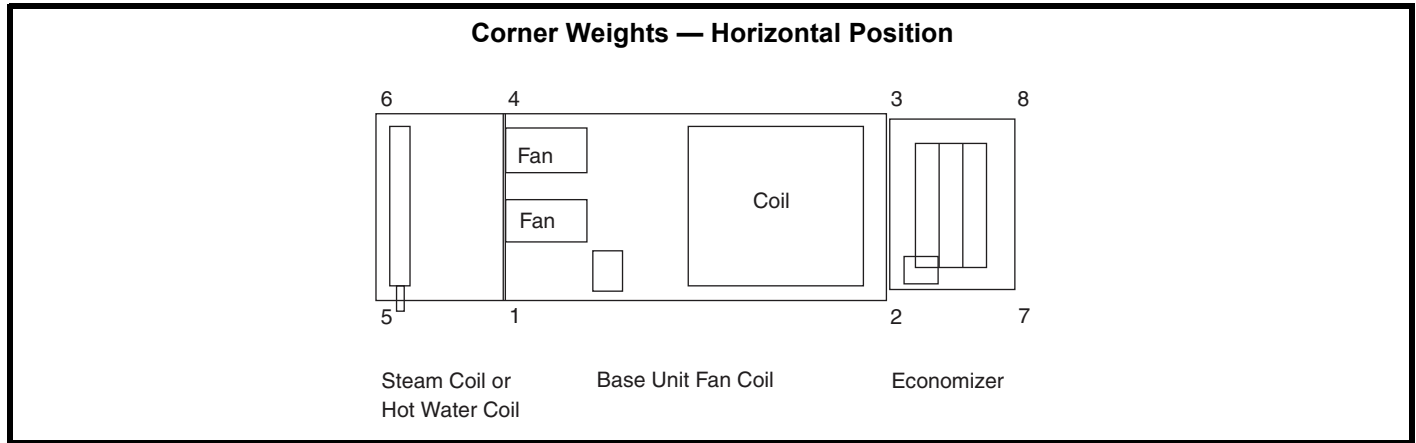

FHX/FHS — Horizontal Position

UNIT SIZE	UNIT OR ACCESSORY NAME		UNIT OR ACCESSORY WEIGHT lb (kg)	CORNER NUMBER (Weight in lb)							
				1	2	3	4	5	6	7	8
FHX072	Fan Coil Base Unit		381 (172.8)	101.0	83.0	89.0	109.0	—	—	—	—
FHX091	Fan Coil Base Unit		385 (174.6)	102.0	83.0	90.0	110.0	—	—	—	—
FHX120	Fan Coil Base Unit		427 (193.7)	113.0	93.0	99.0	122.0	—	—	—	—
FHX072/091/120	Steam Coil	Add	137 (62.1)	25.6	—	—	25.9	42.4	43.0	—	—
	Hot Water Coil	Add	143 (64.9)	26.3	—	—	26.9	44.3	45.5	—	—
	Economizer	Add	128 (58.5)	—	25.5	24.7	—	—	—	39.3	38.1
	Eco + Steam Coil	Add	264 (115.2)	25.6	25.5	24.7	25.9	42.4	43.0	39.3	38.1
	Eco + Hw Coil	Add	271 (122.9)	26.3	25.5	24.7	26.9	44.3	45.5	39.3	38.1
FHS180	Fan Coil Base Unit		713 (323.4)	229.8	182.3	133.2	167.9	—	—	—	—
FHS240	Fan Coil Base Unit		720 (326.6)	232.1	184.1	134.5	169.6	—	—	—	—
FHS180/240	Steam Coil	Add	239 (108.4)	43.2	—	—	43.6	75.8	76.5	—	—
	Hot Water Coil	Add	245 (111.1)	44.5	—	—	44.1	78.7	77.9	—	—
	Economizer	Add	217 (98.4)	—	42.7	39.6	—	—	—	70.1	65.1
	Eco + Steam Coil	Add	456 (206.8)	43.2	42.7	39.6	43.6	75.8	76.5	70.1	65.1
	Eco + Hw Coil	Add	463 (210.0)	44.5	42.7	39.6	44.1	78.7	77.9	70.1	65.1

Base unit dimensions (cont)

Corner Weights — Vertical Position

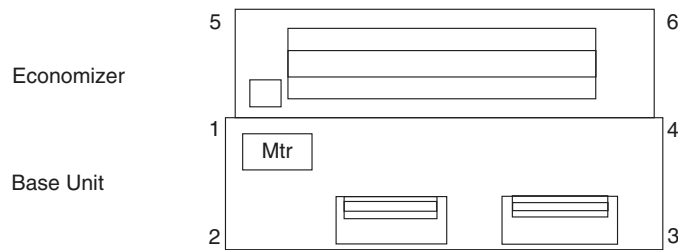

NOTE: Steam, Hot Water and Plenum on top of positions 1, 2, 3, 4

FHX/FHS — Vertical Position

UNIT SIZE	UNIT OR ACCESSORY NAME		UNIT OR ACCESSORY WEIGHT lb (kg)	CORNER NUMBER (Weight in lb)					
				1	2	3	4	5	6
FHX072	Fan Coil Base Unit		381 (172.8)	100.0	96.0	90.0	95.0	—	—
FHX091	Fan Coil Base Unit		385 (174.6)	101.0	97.0	91.0	96.0	—	—
FHX120	Fan Coil Base Unit		427 (193.7)	112.0	107.0	101.0	106.0	—	—
FHX072/091/120	Steam Coil	Add	137 (62.1)	34.5	34.5	34.0	34.0	—	—
	Hot Water Coil	Add	143 (64.9)	36.2	36.2	35.3	35.3	—	—
	Plenum	Add	175 (79.4)	50.8	36.7	36.7	50.8	—	—
	Economizer	Add	128 (58.1)	25.5	—	—	24.7	39.3	38.1
	Eco + Steam Coil	Add	264 (119.7)	59.9	34.5	34.0	58.7	39.3	38.1
	Eco + Hw Coil	Add	271 (122.9)	61.7	36.2	35.3	60.0	39.3	38.1
FHS180	Fan Coil Base Unit		705 (319.8)	196.2	216.0	157.8	143.1	—	—
FHS240	Fan Coil Base Unit		715 (324.3)	198.1	218.1	159.4	144.5	—	—
FHS180/240	Steam Coil	Add	239 (108.4)	60.0	60.0	59.5	59.5	—	—
	Hot Water Coil	Add	245 (111.1)	61.0	61.0	61.6	61.6	—	—
	Plenum	Add	225 (102.1)	72.5	40.0	40.0	72.5	—	—
	Economizer	Add	217 (98.4)	42.7	—	—	39.6	70.1	65.1
	Eco + Steam Coil	Add	456 (206.8)	102.7	60.0	59.5	99.1	70.1	65.1
	Eco + Hw Coil	Add	463 (210.0)	103.7	61.0	61.6	101.2	70.1	65.1

Accessory dimensions

Overhead Suspension Accessory

6-10 Ton Units (FRONT)

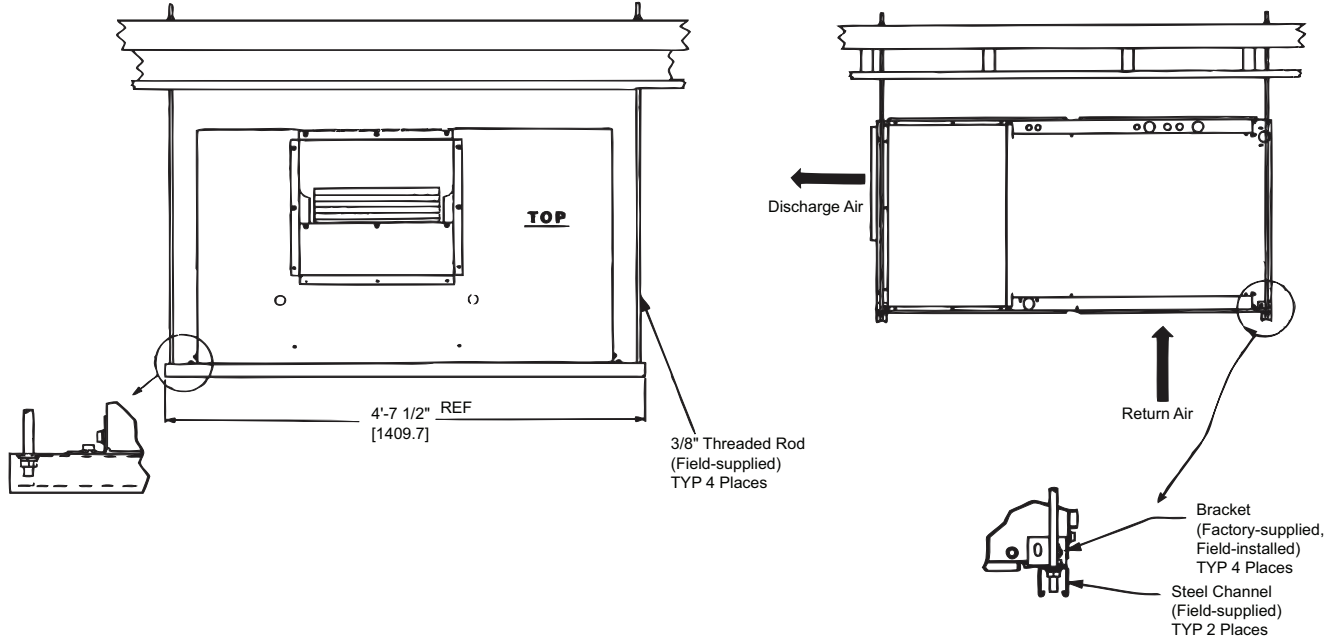

15 and 20 Ton Units (FRONT)

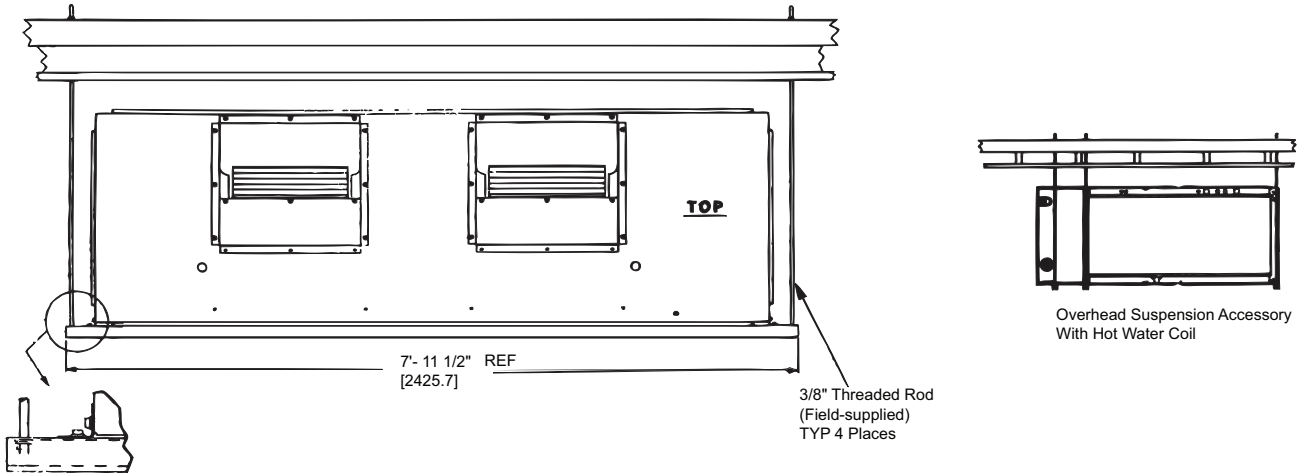

NOTE: Dimensions in [] are in millimeters.

Accessory dimensions (cont)

Plenum, Return-Air Grille, and Subbase Accessories

6-10 Ton Units (FRONT)

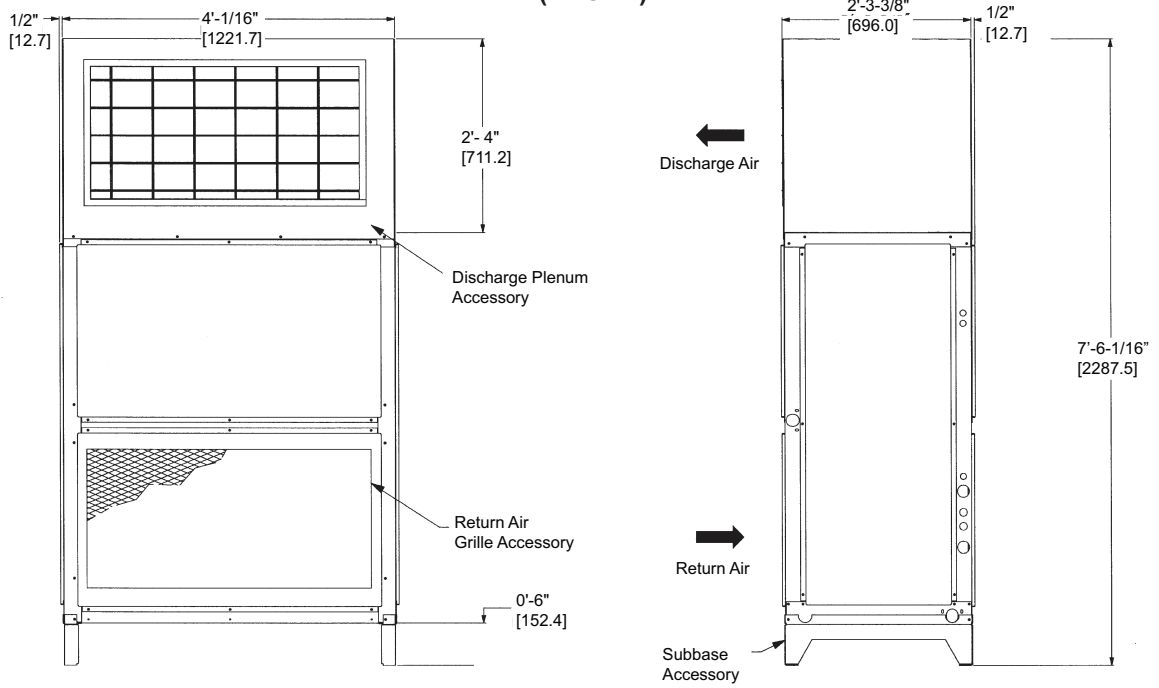

15 and 20 Ton Units (FRONT)

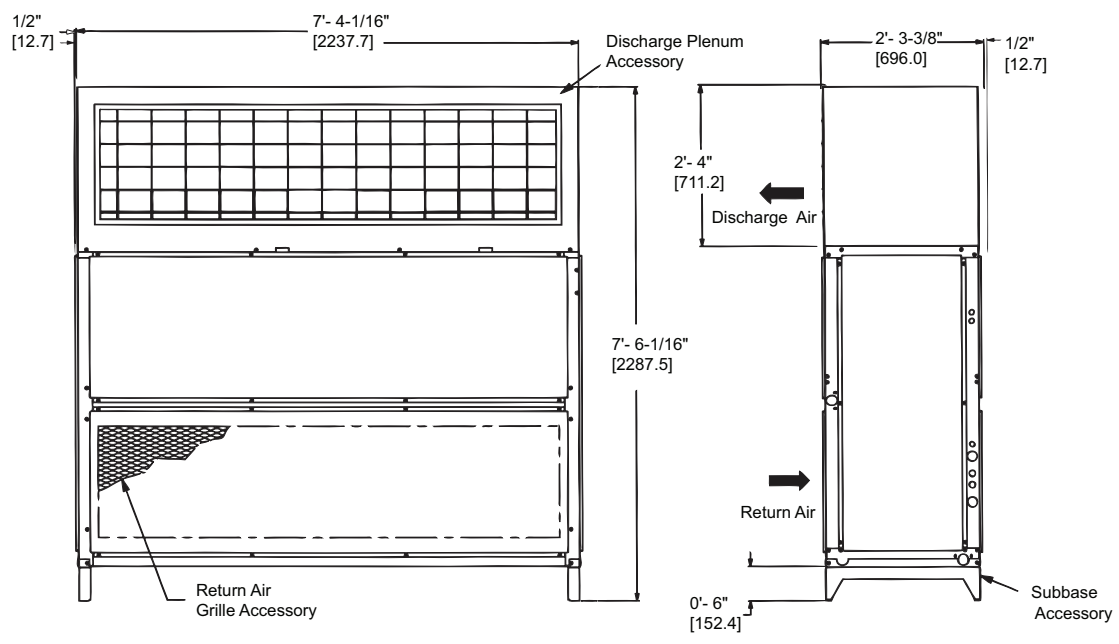

NOTE: Dimensions in [] are in millimeters.

Accessory dimensions (cont)

Hot Water and Steam Coil Accessories

6-10 Ton Units

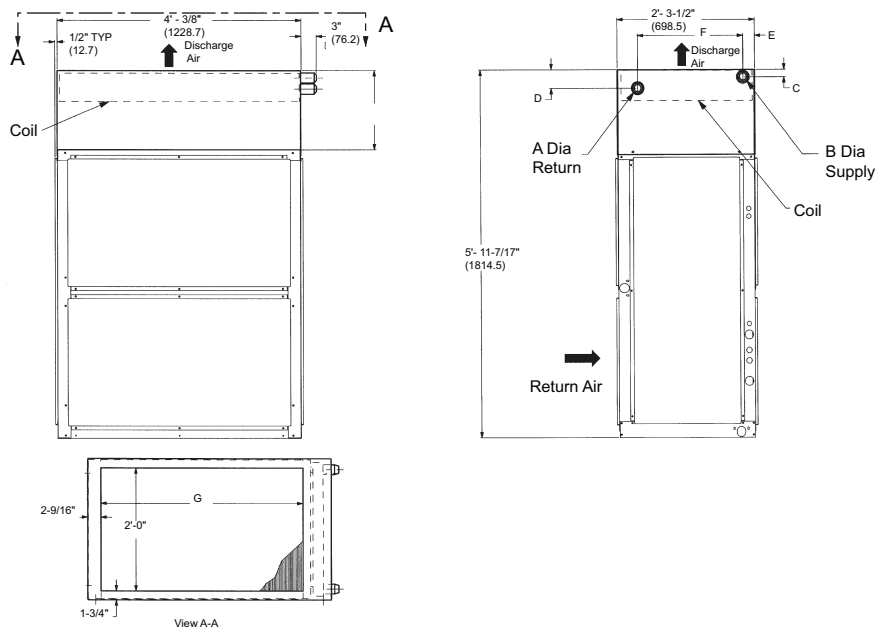

15 and 20 Ton Units

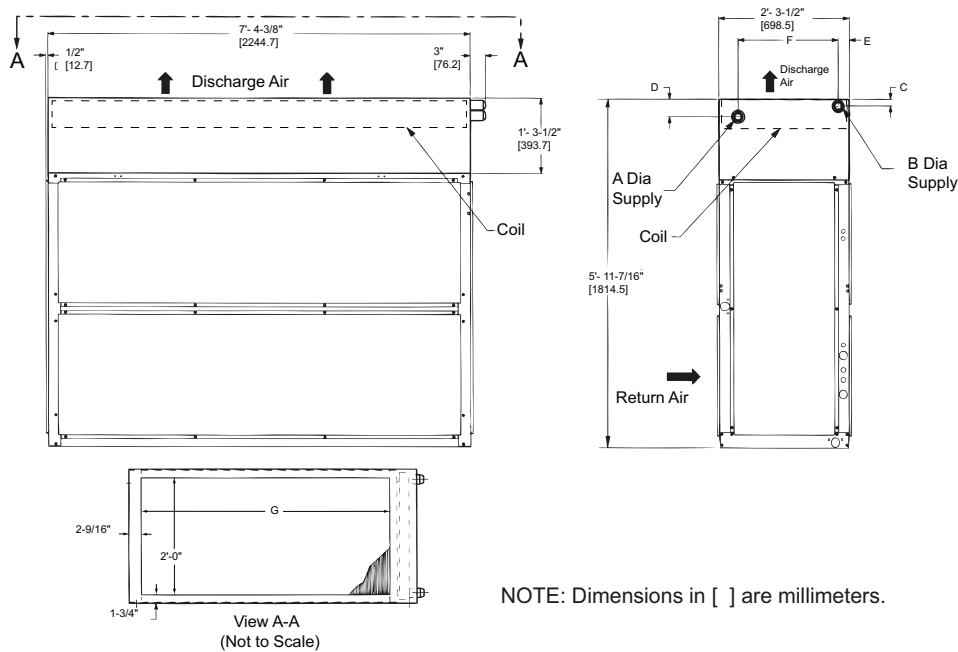

NOTE: Dimensions in [] are millimeters.

FHX072-120

DIMENSIONS	HOT WATER COIL	STEAM COIL
A	1-1/2" MPT [38.1]	1-1/2" MPT [38.1]
B	1-1/2" MPT [38.1]	2-1/2" MPT [63.5]
C	2-3/8" [60.3]	3-1/8" [79.4]
D	4-7/8" [123.8]	3-1/8" [79.4]
E	2-1/8" [54.0]	4-9/16" [115.8]
F	1?-11-1/4" [590.6]	1?-9" [584.2]
G	3?-4" [1016.0]	3?-4" [1016.0]

FHS180/240

DIMENSIONS	HOT WATER COIL	STEAM COIL
A	2" MPT [50.8]	1-1/2" MPT [38.1]
B	2" MPT [50.8]	2-1/2" MPT [63.5]
C	2-3/8" [60.3]	3-1/8" [79.4]
D	4-7/8" [123.8]	3-1/8" [79.4]
E	2-1/8" [54.0]	4-9/16" [115.8]
F	1?-11-1/4" [590.6]	1?-9" [584.2]
G	6?-8" [2032.0]	6?-8" [2032.0]

Accessory dimensions (cont)

Economizer Accessory

6 to 10 Ton Units

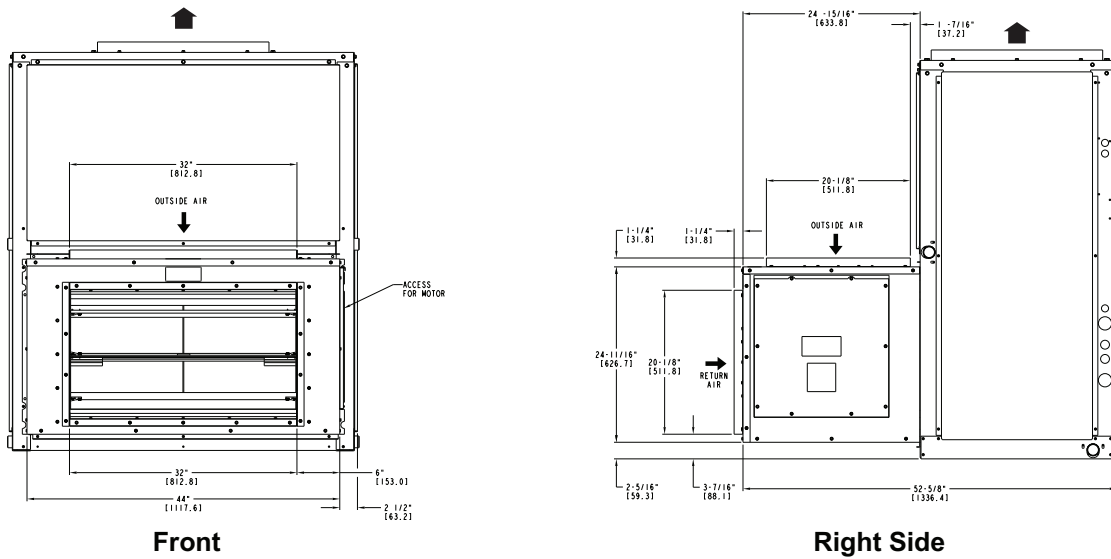

15 and 20 Ton Units

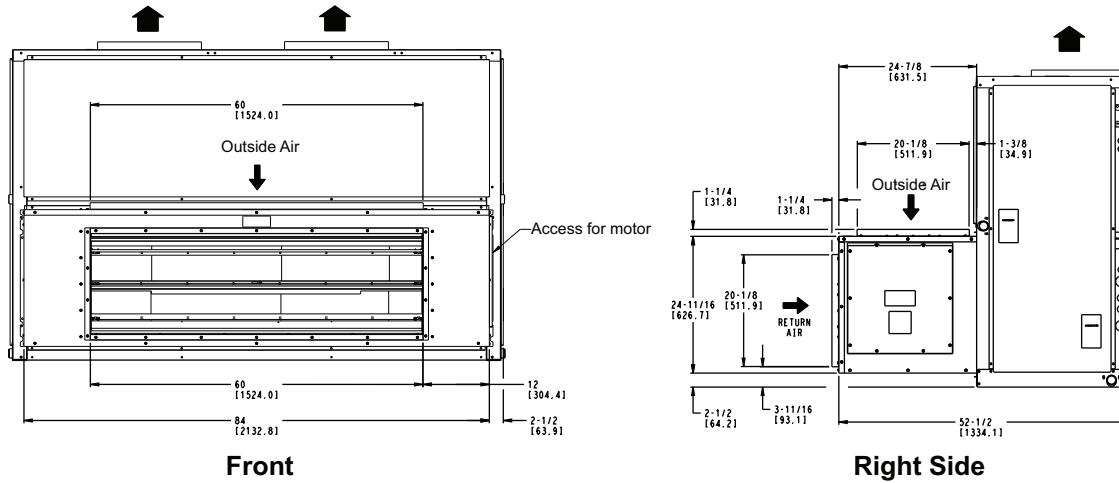

NOTES:

1. For horizontal unit applications, economizer can be attached to end of unit opposite duct connections.
2. Dimensions in [] are millimeters.

Accessory dimensions (cont)

Electric Heat Accessory

6 to 10 Ton Units

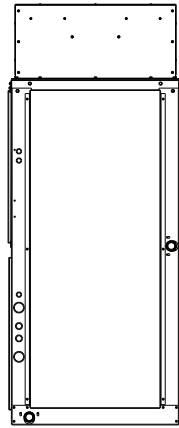
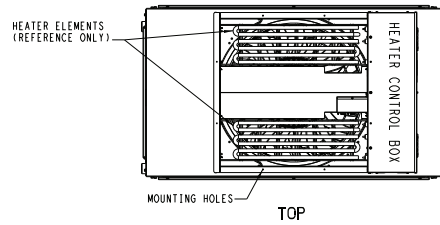

LEFT SIDE

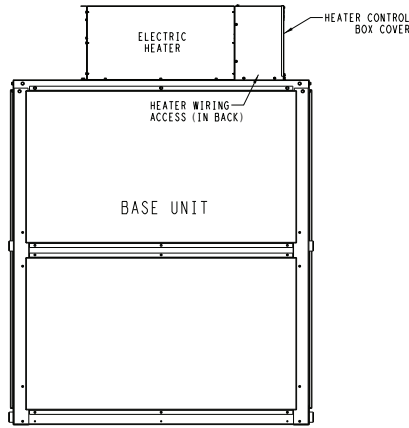

FRONT

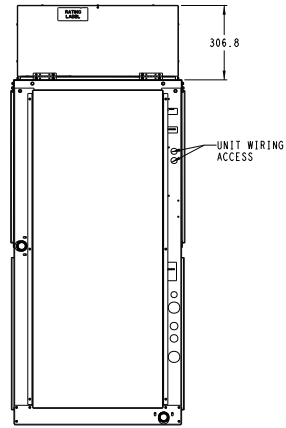

RIGHT SIDE

15 and 20 Ton Units

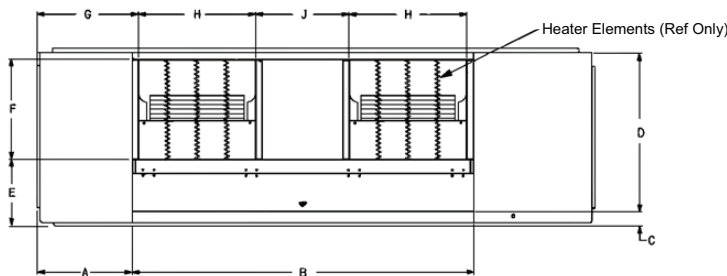
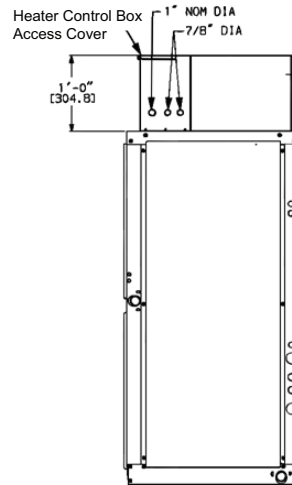
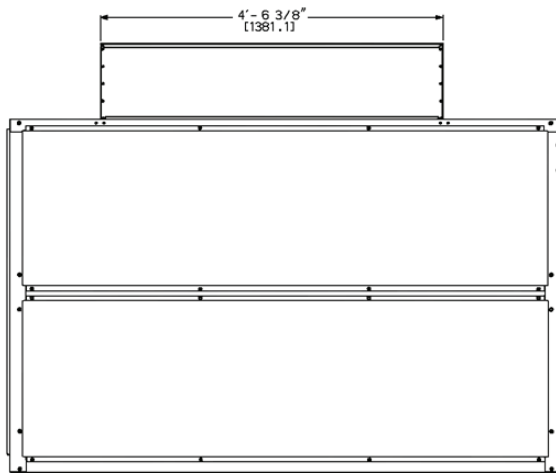

NOTE Dimensions in [] are millimeters.

UNIT SIZE	A	B	C	D	E	F	G	H	J
FHS180/240	17'-3-1/4" [387.4]	4'-6-3/8" [1391.1]	2'-5/16" [58.7]	2'-1-1/4" [641.4]	10'-5/8" [269.9]	17'-4" [406.4]	17'-4-5/16" [414.3]	17'-6-3/4" [476.3]	17'-7/8" [327.0]

Performance data

FHX/FHS Cooling Performance Only^{a,b,c,d}

UNIT	EVAPORATOR AIR		COIL REFRIGERANT TEMP °F (°C) ^e									
	Airflow (cfm)	EWB °F (°C)	30 (-1.1)		35 (1.7)		40 (4.4)		45 (7.2)		50 (10)	
			TC	SHC	TC	SHC	TC	SHC	TC	SHC	TC	SHC
FHX072	1800	72 (22.2)	146.4	71.0	132.1	64.3	116.7	57.3	100.0	49.7	81.8	42.0
		67 (19.4)	121.8	74.0	107.6	66.4	92.4	58.9	76.0	51.2	58.3	43.6
		62 (16.7)	99.3	75.5	85.3	67.9	70.2	60.2	54.9	52.4	44.2	44.2
	2400	72 (22.2)	179.3	87.1	161.7	79.1	142.6	70.4	122.0	61.2	99.5	51.8
		67 (19.4)	149.5	91.5	132.2	82.4	113.3	73.2	93.0	63.8	71.0	54.4
		62 (16.7)	122.3	94.2	105.0	84.9	86.2	75.5	67.6	65.7	55.2	55.2
3000	72 (22.2)	207.4	101.3	186.8	92.0	164.6	81.7	140.6	71.2	114.6	60.4	
	67 (19.4)	173.3	106.7	153.1	96.4	131.2	85.8	107.5	75.1	81.9	64.3	
	62 (16.7)	142.1	110.8	122.0	100.2	100.0	89.3	78.2	78.2	65.2	65.2	
FHX091	2250	72 (22.2)	182.6	88.6	165.5	132.0	146.7	95.2	126.3	64.2	104.0	104.0
		67 (19.4)	152.4	92.7	135.4	83.7	116.9	74.6	96.6	65.2	74.6	55.7
		62 (16.7)	124.9	95.2	107.8	86.0	89.3	76.6	70.2	67.0	56.7	56.7
	3000	72 (22.2)	221.4	107.7	200.6	98.2	177.7	87.8	152.8	76.8	125.7	65.6
		67 (19.4)	185.4	113.8	164.7	103.1	142.1	92.1	117.4	80.9	90.5	69.5
		62 (16.7)	152.4	118.1	131.6	107.2	109.0	95.8	86.2	83.9	70.9	70.9
3750	72 (22.2)	253.9	124.2	229.9	113.3	203.8	101.4	175.1	89.0	143.9	76.3	
	67 (19.4)	213.4	132.1	189.5	120.1	163.4	107.7	135.0	95.0	104.0	82.0	
	62 (16.7)	175.8	138.6	151.9	126.1	125.8	113.1	99.4	99.4	83.3	83.3	
FHX120	3000	72 (22.2)	221.4	107.7	200.6	163.3	177.7	117.8	152.8	79.1	125.7	125.7
		67 (19.4)	185.4	113.8	164.7	103.1	142.1	92.1	117.4	80.9	90.5	69.5
		62 (16.7)	152.4	118.1	131.6	107.2	109.0	95.8	86.2	83.9	70.9	70.9
	4000	72 (22.2)	263.7	129.4	238.7	117.9	211.6	105.6	181.9	92.8	149.4	79.6
		67 (19.4)	221.7	137.8	197.0	125.4	169.9	112.6	140.3	99.4	108.1	85.9
		62 (16.7)	182.9	144.9	158.0	132.1	130.8	118.5	104.0	104.0	87.2	87.2
5000	72 (22.2)	298.3	147.4	270.2	134.4	239.6	120.8	205.9	106.6	169.0	91.9	
	67 (19.4)	251.7	158.5	223.7	144.8	193.0	130.6	159.4	115.9	122.9	100.7	
	62 (16.7)	208.3	168.6	180.1	154.3	149.1	138.5	120.4	120.4	101.5	101.5	
FHS180	4500	72 (22.2)	360.1	174.8	326.2	260.8	289.1	187.9	248.7	126.7	204.7	204.7
		67 (19.4)	300.7	183.1	267.0	165.3	230.4	147.2	190.2	128.6	146.8	109.9
		62 (16.7)	246.5	188.2	212.7	170.0	176.0	151.4	138.3	132.3	111.9	111.9
	6000	72 (22.2)	435.7	212.1	394.7	193.6	349.4	172.9	300.3	151.3	246.8	129.2
		67 (19.4)	365.2	224.3	324.1	203.3	279.5	181.6	230.8	159.5	177.6	136.9
		62 (16.7)	300.2	233.1	259.1	211.5	214.3	189.0	169.6	165.5	139.7	139.7
7500	72 (22.2)	499.1	244.5	451.7	222.9	400.1	199.4	343.7	175.1	282.2	150.0	
	67 (19.4)	419.5	260.2	372.5	236.6	321.1	212.2	265.0	187.0	203.9	161.3	
	62 (16.7)	345.9	273.1	298.6	248.6	247.0	222.8	195.7	195.7	164.0	164.0	
FHS240	6000	72 (22.2)	443.7	215.8	406.1	329.5	363.8	240.8	317.1	164.0	265.2	265.2
		67 (19.4)	374.1	229.7	335.9	210.2	293.5	189.7	246.5	168.3	194.4	146.0
		62 (16.7)	309.8	240.3	271.0	219.9	227.9	198.4	182.4	175.5	149.2	149.2
	8000	72 (22.2)	523.5	257.1	479.7	236.8	430.7	214.8	375.8	191.3	314.5	166.4
		67 (19.4)	443.7	276.5	399.2	254.6	349.3	231.1	293.7	206.4	232.0	180.5
		62 (16.7)	369.1	293.6	323.5	270.3	272.6	245.2	220.6	217.2	184.8	184.8
10000	72 (22.2)	586.4	289.8	538.6	268.1	484.6	244.5	423.1	218.9	354.4	191.6	
	67 (19.4)	499.5	316.4	450.2	292.8	394.6	267.3	332.3	240.1	262.8	211.4	
	62 (16.7)	417.2	340.3	366.3	314.9	309.4	286.4	253.1	253.1	215.4	215.4	

NOTE(S):

- a. Ratings based on approximately 15°F superheat leaving coil.
- b. Direct interpolation is permissible. Do not extrapolate.
- c. Evaporator fan heat not deducted from ratings.
- d. Use wet and dry bulb formulas below.
- e. SHC is based on 80°F db temperature of air entering evaporator coil.

Wet and Dry Bulb Formulas:

$$\text{Leaving db} = \text{entering db} - \frac{\text{sensible heat capacity (Btuh)}}{1.1 \times \text{cfm}}$$

$$\text{Leaving wb} = \text{wet-bulb temperature corresponding to enthalpy of air leaving coil (h}_{|wb})$$

$$h_{|wb} = h_{ewb} - \frac{\text{total capacity (Btuh)}}{4.5 \times \text{cfm}}$$

where $h_{|wb}$ = enthalpy of air entering coil

LEGEND

- db — Dry Bulb Temp (°F)
- Ewb — Entering Wet Bulb Temp (°F)
- lwb — Leaving Wet Bulb Temp (°F)
- SHC — Sensible Heat Capacity (1000 Btuh)
- TC — Total Capacity (1000 Btuh)

Performance data (cont)

Hydronic Heating Capacity^{a,b,c}

UNIT	AIRFLOW (cfm)	1-ROW STEAM ^d		2-ROW HOT WATER COIL ^e			
		Cap.	Ldb	Cap.	Ldb	Water Flow (Gpm)	PD
FHX072	1,800	146	134	156.0	140	15.6	3.4
	2,400	173	126	183.0	131	18.3	4.3
	3,000	209	123	206.0	124	20.6	5.2
FHX091	2,250	168	129	174.0	133	17.4	4.0
	3,000	209	123	206.0	124	20.6	5.2
	3,750	240	117	238.0	118	23.8	6.5
FHX120	3,000	209	123	299.0	152	29.9	5.0
	4,000	243	115	275.0	124	27.5	6.6
	5,000	279	111	316.0	119	31.6	8.2
FHS180	4,500	402	141	412.0	145	41.2	4.5
	6,000	458	129	471.0	133	47.1	5.5
	7,500	479	118	529.0	125	52.9	6.6
FHS240	6,000	458	129	506.0	138	50.6	5.1
	8,000	487	115	584.0	128	58.4	6.3
	10,000	499	105	652.0	120	65.2	7.5

NOTE(S):

- a. Maximum operating limits for heating coils: 20 psig at 260°F.
- b. See Leaving Air Dry Bulb formula below.
- c. See Heating Correction Factors table below.
- d. Based on 5 psig steam, 60°F entering temperature. All steam coils are non-freeze type.
- e. Based on 200°F entering water, 20°F water temperature drop, 60°F entering-air temperature.

Leaving Air Dry Bulb Formula:

$$\text{Leaving db} = \text{entering db} + \frac{\text{Capacity (Btuh)}}{1.1 \times \text{cfm}}$$

LEGEND

- Cap. — Capacity (Btuh in 1000)
- Ldb — Leaving Air Dry Bulb Temp (°F)
- PD — Pressure Drop (ft water)

Heating Correction Factors

HOT WATER COIL						
Water Temp. Drop °F (°C)	Ent. Water Temp. °F (°C)	Entering-Air Temp °F (°C)				
		40 (4.4)	50 (10)	60 (15.6)	70 (21.1)	80 (26.7)
10 (-12.2)	140 (60)	0.72	0.64	0.57	0.49	0.41
	160 (71)	0.89	0.81	0.74	0.66	0.58
	180 (82)	1.06	0.98	0.90	0.83	0.75
	200 (93)	1.22	1.15	1.07	1.00	0.92
	220 (104)	1.39	1.32	1.24	1.17	1.09
20 (-6.7)	140 (60)	0.64	0.57	0.49	0.41	0.33
	160 (71)	0.81	0.74	0.66	0.58	0.51
	180 (82)	0.98	0.91	0.83	0.75	0.68
	200 (93)	1.15	1.08	1.00	0.93	0.85
	220 (104)	1.32	1.25	1.17	1.10	1.02
30 (-1.1)	140 (60)	0.56	0.49	0.41	0.33	0.24
	160 (71)	0.74	0.66	0.58	0.51	0.43
	180 (82)	0.91	0.83	0.76	0.68	0.60
	200 (93)	1.08	1.00	0.93	0.85	0.78
	220 (104)	1.25	1.18	1.10	1.03	0.95

STEAM COIL					
Steam Pressure (psig)	Entering-Air Temp. °F (°C)				
	40 (4.4)	50 (10)	60 (15.6)	70 (21.1)	80 (26.7)
0	1.06	0.98	0.91	0.85	0.78
2	1.09	1.02	0.95	0.89	0.82
5	1.13	1.06	1.00	0.93	0.87

NOTE: Multiply capacity given in the Hydronic Heating Capacities table by the correction factor for conditions at which unit is actually operating. Correct leaving-air temperature using formula in Note b of Hydronic Heating Capacity table.

Performance data (cont)

Duct Sound Power Levels (Lw)^{a,b,c}

MODEL	CFM	dB(A)	OCTAVE BAND CENTER FREQUENCY (Hz)						
			63	125	250	500	1000	2000	4000
FHX072	2,400	86.3	93.2	89.2	85.2	84.2	80.2	78.2	74.2
FHX091	3,000	88.3	95.3	91.3	87.3	86.3	82.3	80.3	76.3
FHX120	4,000	92.0	99.0	95.0	91.0	90.0	86.0	84.0	80.0
FHS180	6,000	92.9	99.2	95.2	91.2	92.2	86.2	84.2	80.2
FHS240	8,000	96.4	102.6	98.6	94.6	95.6	89.2	87.6	83.6

NOTE(S):

- a. The above estimated sound power levels are based upon the ASHRAE calculation approach from the ASHRAE HVAC Systems and Applications handbook.
- b. Since this data is calculated, these sound power levels may be different than the actual sound power levels.
- c. The acoustic center of the unit is located at the geometric center of the unit.

LEGEND

ASHRAE — American Society of Heating and Air Conditioning, Inc.
 HVAC — Heating, Ventilation and Air Conditioning

Factory-Supplied Filter Pressure Drop

UNIT	AIRFLOW (cfm)	PRESSURE DROP (in. wg)
FHX072	1,800	0.05
	2,400	0.08
	3,000	0.11
FHX091	2,250	0.07
	3,000	0.11
	3,750	0.15
FHX120	3,000	0.11
	4,000	0.17
	5,000	0.23
FHS180	4,500	0.08
	6,000	0.12
	7,500	0.17
FHS240	6,000	0.12
	8,000	0.19
	10,000	0.26

Accessory Plenum Air Throw Data (ft)^a

UNIT	AIRFLOW (cfm)	VANE DEFLECTION		
		Straight	21-1/2°	45°
FHX072	2,400	39	33	24
FHX091	3,000	45	38	28
FHX120	4,000	55	46	33
FHS180	6,000	50	43	31
FHS240	8,000	60	51	37

NOTE(S):

- a. Throw distances shown are 75 fpm terminal velocity. Use the following multipliers to determine throw values for the other terminal velocities.

TERMINAL VELOCITY (Fpm)	THROW FACTOR
50	X 1.50
100	X 0.75
150	X 0.50

Accessory Pressure Drop — in.wg

UNIT	AIRFLOW (cfm)	DISCHARGE PLENUM	RETURN AIR GRILLE	HOT WATER	STEAM	ELECTRIC	ECONOMIZER
FHX072	1,800	0.06	0.01	0.10	0.10	0.04	0.05
	2,400	0.10	0.01	0.16	0.16	0.06	0.07
	3,000	0.14	0.02	0.23	0.23	0.10	0.09
FHX091	2,250	0.09	0.01	0.15	0.15	0.06	0.06
	3,000	0.14	0.02	0.23	0.23	0.10	0.09
	3,750	0.21	0.03	0.35	0.35	0.15	0.15
FHX120	3,000	0.14	0.02	0.23	0.23	0.10	0.09
	4,000	0.22	0.04	0.37	0.37	0.17	0.17
	5,000	0.32	0.06	0.53	0.53	0.26	0.28
FHS180	4,500	0.10	0.01	0.15	0.15	0.06	0.06
	6,000	0.16	0.02	0.23	0.23	0.10	0.09
	7,500	0.23	0.03	0.33	0.33	0.15	0.15
FHS240	6,000	0.16	0.02	0.23	0.23	0.10	0.09
	8,000	0.26	0.04	0.37	0.37	0.17	0.17
	10,000	0.37	0.06	0.53	0.53	0.26	0.28

Fan data

GENERAL FAN PERFORMANCE NOTES

1. Interpolation is permissible. Do not extrapolate.
2. External static pressure is the static pressure difference between the return duct and the supply duct plus the static pressure caused by any FIOPs or accessories.
3. Tabular data accounts for pressure loss due to clean filters, unit casing, wet coils, and highest gas heat exchanger (when gas heat unit).
4. Factory options and accessories may effect static pressure losses. Selection software is available, through your salesperson, to help you select the best motor/drive combination for your application.
5. The fan performance tables offer motor/drive recommendations. In cases when two motor/drive combinations would work, we recommend the lower horsepower option.
6. For information on the electrical properties of our motors, please see the Electrical information section of this book.
7. For more information on the performance limits of our motors, see the application data section of this book.
8. The EPACT (Energy Policy Act of 1992) regulates energy requirements for specific types of indoor fan motors. Motors regulated by EPACT include any general purpose, T-frame (three-digit, 143 and larger), single-speed, foot mounted, polyphase, squirrel cage induction motors of NEMA (National Electrical Manufacturers Association) design A and B, manufactured for use in the United States. Ranging from 1 to 200 Hp, these continuous-duty motors operate on 230 and 460 volt, 60 Hz power. If a motor does not fit into these specifications, the motor does not have to be replaced by an EPACT compliant energy-efficient motor. Variable-speed motors are exempt from EPACT compliance requirements.

Fan data (cont)

FHX072 Fan Data (rpm - bhp)

CFM	AVAILABLE EXTERNAL STATIC PRESSURE (in. wg)									
	0.2		0.4		0.6		0.8		1.0	
	rpm	bhp	rpm	bhp	rpm	bhp	rpm	bhp	rpm	bhp
1800	788	0.18	942	0.31	1081	0.48	1202	0.67	1308	0.88
1950	828	0.20	973	0.34	1107	0.52	1227	0.71	1333	0.92
2100	870	0.23	1005	0.37	1134	0.55	1252	0.75	1358	0.97
2250	914	0.26	1040	0.41	1163	0.59	1278	0.80	1383	1.02
2400	958	0.30	1077	0.45	1194	0.63	1305	0.84	1409	1.07
2550	1004	0.34	1115	0.50	1226	0.68	1334	0.89	1435	1.13
2700	1050	0.39	1155	0.55	1261	0.74	1364	0.95	1462	1.18
2850	1097	0.44	1197	0.60	1297	0.79	1395	1.01	1491	1.25
3000	1144	0.50	1239	0.66	1334	0.86	1429	1.08	1521	1.32

CFM	AVAILABLE EXTERNAL STATIC PRESSURE (in. wg)									
	1.2		1.4		1.6		1.8		2.0	
	rpm	bhp	rpm	bhp	rpm	bhp	rpm	bhp	rpm	bhp
1800	1403	1.09	1491	1.32	1571	1.55	1647	1.79	1718	2.04
1950	1429	1.14	1517	1.38	1598	1.62	1674	1.87	1745	2.13
2100	1454	1.20	1542	1.44	1624	1.69	1700	1.95	1772	2.21
2250	1479	1.25	1568	1.50	1650	1.76	1726	2.02	1799	2.30
2400	1504	1.31	1593	1.57	1675	1.83	1752	2.11	1825	2.39
2550	1529	1.37	1618	1.64	1700	1.91	1777	2.19	1850	2.48
2700	1555	1.44	1643	1.70	1725	1.98	1802	2.27	1875	2.57
2850	1582	1.50	1668	1.78	1750	2.06	1827	2.36	1900	2.66
3000	1610	1.58	1695	1.86	1775	2.14	1852	2.45	1925	2.76

Medium Static 788-1695 rpm, 1.86 max bhp

High Static 788-1925 rpm, 2.76 max bhp

FHX072 Medium Static Fan Data (rpm - vdc)

CFM	AVAILABLE EXTERNAL STATIC PRESSURE (in. wg)									
	0.2		0.4		0.6		0.8		1.0	
	rpm	Vdc	rpm	Vdc	rpm	Vdc	rpm	Vdc	rpm	Vdc
1800	788	3.8	942	4.6	1081	5.3	1202	5.9	1308	6.4
1950	828	4.0	973	4.7	1107	5.4	1227	6.0	1333	6.6
2100	870	4.2	1005	4.9	1134	5.5	1252	6.2	1358	6.7
2250	914	4.4	1040	5.1	1163	5.7	1278	6.3	1383	6.8
2400	958	4.6	1077	5.3	1194	5.9	1305	6.4	1409	7.0
2550	1004	4.9	1115	5.4	1226	6.0	1334	6.6	1435	7.1
2700	1050	5.1	1155	5.7	1261	6.2	1364	6.7	1462	7.2
2850	1097	5.4	1197	5.9	1297	6.4	1395	6.9	1491	7.4
3000	1144	5.6	1239	6.1	1334	6.6	1429	7.1	1521	7.5

CFM	AVAILABLE EXTERNAL STATIC PRESSURE (in. wg)									
	1.2		1.4		1.6		1.8		2.0	
	rpm	Vdc	rpm	Vdc	rpm	Vdc	rpm	Vdc	rpm	Vdc
1800	1403	6.9	1491	7.4	—	—	—	—	—	—
1950	1429	7.1	1517	7.5	—	—	—	—	—	—
2100	1454	7.2	1542	7.6	—	—	—	—	—	—
2250	1479	7.3	1568	7.8	—	—	—	—	—	—
2400	1504	7.4	1593	7.9	—	—	—	—	—	—
2550	1529	7.6	1618	8.0	—	—	—	—	—	—
2700	1555	7.7	1643	8.2	—	—	—	—	—	—
2850	1582	7.9	1668	8.3	—	—	—	—	—	—
3000	1610	8.0	1695	8.4	—	—	—	—	—	—

Medium Static 788-1695 rpm

Fan data (cont)

FHX072 High Static Fan Data (rpm - vdc)

CFM	AVAILABLE EXTERNAL STATIC PRESSURE (in. wg)									
	0.2		0.4		0.6		0.8		1.0	
	rpm	Vdc	rpm	Vdc	rpm	Vdc	rpm	Vdc	rpm	Vdc
1800	788	3.5	942	4.2	1081	4.8	1202	5.4	1308	5.9
1950	828	3.7	973	4.3	1107	5.0	1227	5.5	1333	6.0
2100	870	3.9	1005	4.5	1134	5.1	1252	5.6	1358	6.1
2250	914	4.1	1040	4.6	1163	5.2	1278	5.7	1383	6.2
2400	958	4.3	1077	4.8	1194	5.4	1305	5.9	1409	6.3
2550	1004	4.5	1115	5.0	1226	5.5	1334	6.0	1435	6.5
2700	1050	4.7	1155	5.2	1261	5.7	1364	6.1	1462	6.6
2850	1097	4.9	1197	5.4	1297	5.8	1395	6.3	1491	6.7
3000	1144	5.1	1239	5.6	1334	6.0	1429	6.4	1521	6.9

CFM	AVAILABLE EXTERNAL STATIC PRESSURE (in. wg)									
	1.2		1.4		1.6		1.8		2.0	
	rpm	Vdc	rpm	Vdc	rpm	Vdc	rpm	Vdc	rpm	Vdc
1800	1403	6.3	1491	6.7	1571	7.1	1647	7.4	1718	7.8
1950	1429	6.4	1517	6.8	1598	7.2	1674	7.6	1745	7.9
2100	1454	6.6	1542	7.0	1624	7.3	1700	7.7	1772	8.0
2250	1479	6.7	1568	7.1	1650	7.5	1726	7.8	1799	8.1
2400	1504	6.8	1593	7.2	1675	7.6	1752	7.9	1825	8.3
2550	1529	6.9	1618	7.3	1700	7.7	1777	8.0	1850	8.4
2700	1555	7.0	1643	7.4	1725	7.8	1802	8.2	1875	8.5
2850	1582	7.1	1668	7.5	1750	7.9	1827	8.3	1900	8.6
3000	1610	7.3	1695	7.7	1775	8.0	1852	8.4	1925	8.7

High Static 788-1925 rpm

Fan data (cont)

FHX091 Fan Data (rpm - bhp)

CFM	AVAILABLE EXTERNAL STATIC PRESSURE (in. wg)									
	0.2		0.4		0.6		0.8		1.0	
	rpm	bhp	rpm	bhp	rpm	bhp	rpm	bhp	rpm	bhp
2250	884	0.23	1009	0.37	1131	0.54	1247	0.74	1354	0.95
2440	937	0.27	1053	0.42	1168	0.59	1279	0.79	1383	1.01
2625	991	0.32	1099	0.47	1206	0.64	1311	0.84	1412	1.07
2815	1048	0.37	1149	0.53	1249	0.70	1348	0.90	1445	1.13
3000	1103	0.43	1199	0.59	1293	0.77	1386	0.97	1478	1.20
3190	1161	0.50	1252	0.66	1340	0.85	1428	1.05	1516	1.28
3375	1218	0.57	1304	0.74	1388	0.93	1471	1.14	1554	1.37
3565	1277	0.66	1359	0.83	1438	1.02	1517	1.24	1596	1.47
3750	1335	0.75	1413	0.93	1489	1.13	1564	1.34	1639	1.58

CFM	AVAILABLE EXTERNAL STATIC PRESSURE (in. wg)									
	1.2		1.4		1.6		1.8		2.0	
	rpm	bhp	rpm	bhp	rpm	bhp	rpm	bhp	rpm	bhp
2250	1452	1.18	1542	1.43	1625	1.68	1703	1.94	1776	2.21
2440	1480	1.25	1570	1.50	1653	1.76	1731	2.03	1805	2.31
2625	1507	1.31	1597	1.57	1680	1.83	1759	2.11	1833	2.40
2815	1537	1.38	1625	1.64	1708	1.91	1787	2.20	1861	2.50
3000	1568	1.45	1654	1.72	1736	2.00	1814	2.29	1888	2.60
3190	1602	1.54	1685	1.80	1765	2.09	1842	2.39	1916	2.70
3375	1636	1.62	1717	1.90	1795	2.18	1871	2.49	1944	2.81
3565	1675	1.73	1752	2.00	1828	2.29	1902	2.60	1973	2.92
3750	1714	1.83	1788	2.11	1862	2.41	1933	2.71	2003	3.04

Medium Static 884-1788 rpm, 2.11 max bhp

High Static 884-2003 rpm, 3.04 max bhp

FHX091 Medium Static Fan Data (rpm - vdc)

CFM	AVAILABLE EXTERNAL STATIC PRESSURE (in. wg)									
	0.2		0.4		0.6		0.8		1.0	
	rpm	Vdc	rpm	Vdc	rpm	Vdc	rpm	Vdc	rpm	Vdc
2250	884	4.3	1009	4.9	1131	5.5	1247	6.1	1354	6.7
2440	937	4.5	1053	5.1	1168	5.7	1279	6.3	1383	6.8
2625	991	4.8	1099	5.4	1206	5.9	1311	6.5	1412	7.0
2815	1048	5.1	1149	5.6	1249	6.1	1348	6.6	1445	7.1
3000	1103	5.4	1199	5.9	1293	6.4	1386	6.8	1478	7.3
3190	1161	5.7	1252	6.2	1340	6.6	1428	7.1	1516	7.5
3375	1218	6.0	1304	6.4	1388	6.9	1471	7.3	1554	7.7
3565	1277	6.3	1359	6.7	1438	7.1	1517	7.5	1596	7.9
3750	1335	6.6	1413	7.0	1489	7.4	1564	7.8	1639	8.1

CFM	AVAILABLE EXTERNAL STATIC PRESSURE (in. wg)									
	1.2		1.4		1.6		1.8		2.0	
	rpm	Vdc	rpm	Vdc	rpm	Vdc	rpm	Vdc	rpm	Vdc
2250	1452	7.2	1542	7.6	—	—	—	—	—	—
2440	1480	7.3	1570	7.8	—	—	—	—	—	—
2625	1507	7.5	1597	7.9	—	—	—	—	—	—
2815	1537	7.6	1625	8.1	—	—	—	—	—	—
3000	1568	7.8	1654	8.2	—	—	—	—	—	—
3190	1602	8.0	1685	8.4	—	—	—	—	—	—
3375	1636	8.1	1717	8.5	—	—	—	—	—	—
3565	1675	8.3	1752	8.7	—	—	—	—	—	—
3750	1714	8.5	1788	8.9	—	—	—	—	—	—

Medium Static 884-1788 rpm

Fan data (cont)

FHX091 High Static Fan Data (rpm - vdc)

CFM	AVAILABLE EXTERNAL STATIC PRESSURE (in. wg)									
	0.2		0.4		0.6		0.8		1.0	
	rpm	Vdc	rpm	Vdc	rpm	Vdc	rpm	Vdc	rpm	Vdc
2250	884	3.9	1009	4.5	1131	5.1	1247	5.6	1354	6.1
2440	937	4.2	1053	4.7	1168	5.2	1279	5.7	1383	6.2
2625	991	4.4	1099	4.9	1206	5.4	1311	5.9	1412	6.4
2815	1048	4.7	1149	5.1	1249	5.6	1348	6.1	1445	6.5
3000	1103	4.9	1199	5.4	1293	5.8	1386	6.2	1478	6.7
3190	1161	5.2	1252	5.6	1340	6.0	1428	6.4	1516	6.8
3375	1218	5.5	1304	5.9	1388	6.3	1471	6.6	1554	7.0
3565	1277	5.7	1359	6.1	1438	6.5	1517	6.8	1596	7.2
3750	1335	6.0	1413	6.4	1489	6.7	1564	7.1	1639	7.4

CFM	AVAILABLE EXTERNAL STATIC PRESSURE (in. wg)									
	1.2		1.4		1.6		1.8		2.0	
	rpm	Vdc	rpm	Vdc	rpm	Vdc	rpm	Vdc	rpm	Vdc
2250	1452	6.5	1542	7.0	1625	7.3	1703	7.7	1776	8.0
2440	1480	6.7	1570	7.1	1653	7.5	1731	7.8	1805	8.2
2625	1507	6.8	1597	7.2	1680	7.6	1759	8.0	1833	8.3
2815	1537	6.9	1625	7.3	1708	7.7	1787	8.1	1861	8.4
3000	1568	7.1	1654	7.5	1736	7.9	1814	8.2	1888	8.6
3190	1602	7.2	1685	7.6	1765	8.0	1842	8.3	1916	8.7
3375	1636	7.4	1717	7.8	1795	8.1	1871	8.5	1944	8.8
3565	1675	7.6	1752	7.9	1828	8.3	1902	8.6	1973	9.0
3750	1714	7.8	1788	8.1	1862	8.4	1933	8.8	2003	9.1

High Static 884-2003 rpm

Fan data (cont)

FHX120 Fan Data (rpm - bhp)

CFM	AVAILABLE EXTERNAL STATIC PRESSURE (in. wg)									
	0.2		0.4		0.6		0.8		1.0	
	rpm	bhp	rpm	bhp	rpm	bhp	rpm	bhp	rpm	bhp
3000	1080	0.40	1175	0.55	1268	0.72	1361	0.92	1453	1.14
3250	1154	0.48	1243	0.64	1329	0.81	1415	1.01	1501	1.24
3500	1229	0.57	1312	0.74	1393	0.92	1473	1.13	1553	1.35
3750	1305	0.68	1384	0.86	1459	1.04	1534	1.25	1609	1.48
4000	1381	0.80	1456	0.99	1527	1.18	1598	1.40	1668	1.63
4250	1458	0.94	1529	1.13	1597	1.34	1664	1.56	1730	1.79
4500	1535	1.09	1603	1.29	1668	1.50	1731	1.73	1794	1.97
4750	1613	1.26	1678	1.47	1740	1.69	1800	1.92	1860	2.17
5000	1691	1.45	1753	1.67	1813	1.90	1870	2.14	1927	2.39

CFM	AVAILABLE EXTERNAL STATIC PRESSURE (in. wg)									
	1.2		1.4		1.6		1.8		2.0	
	rpm	bhp	rpm	bhp	rpm	bhp	rpm	bhp	rpm	bhp
3000	1543	1.38	1629	1.64	1712	1.91	1791	2.20	1866	2.50
3250	1586	1.48	1668	1.74	1748	2.02	1825	2.31	1899	2.62
3500	1632	1.59	1711	1.86	1787	2.14	1862	2.44	1935	2.75
3750	1683	1.73	1757	1.99	1830	2.28	1902	2.58	1972	2.89
4000	1738	1.88	1807	2.14	1877	2.43	1945	2.73	2013	3.05
4250	1795	2.04	1861	2.31	1927	2.60	1992	2.90	—	—
4500	1856	2.23	1918	2.50	1980	2.79	2042	3.09	—	—
4750	1919	2.43	1977	2.71	2036	3.00	—	—	—	—
5000	1983	2.66	2039	2.94	—	—	—	—	—	—

Medium Static 1080-1918 rpm, 2.50 max bhp

High Static 1080-2013 rpm, 3.05 max bhp

FHX120 Medium Static Fan Data (rpm - vdc)

CFM	AVAILABLE EXTERNAL STATIC PRESSURE (in. wg)									
	0.2		0.4		0.6		0.8		1.0	
	rpm	Vdc	rpm	Vdc	rpm	Vdc	rpm	Vdc	rpm	Vdc
3000	1080	5.3	1175	5.8	1268	6.2	1361	6.7	1453	7.2
3250	1154	5.6	1243	6.1	1329	6.5	1415	7.0	1501	7.4
3500	1229	6.0	1312	6.5	1393	6.9	1473	7.3	1553	7.7
3750	1305	6.4	1384	6.8	1459	7.2	1534	7.6	1609	8.0
4000	1381	6.8	1456	7.2	1527	7.6	1598	7.9	1668	8.3
4250	1458	7.2	1529	7.6	1597	7.9	1664	8.3	1730	8.6
4500	1535	7.6	1603	8.0	1668	8.3	1731	8.6	1794	8.9
4750	1613	8.0	1678	8.3	1740	8.7	1800	9.0	1860	9.3
5000	1691	8.4	1753	8.7	1813	9.0	1870	9.3	1927	9.6

CFM	AVAILABLE EXTERNAL STATIC PRESSURE (in. wg)									
	1.2		1.4		1.6		1.8		2.0	
	rpm	Vdc	rpm	Vdc	rpm	Vdc	rpm	Vdc	rpm	Vdc
3000	1543	7.6	1629	8.1	—	—	—	—	—	—
3250	1586	7.9	1668	8.3	—	—	—	—	—	—
3500	1632	8.1	1711	8.5	—	—	—	—	—	—
3750	1683	8.4	1757	8.8	—	—	—	—	—	—
4000	1738	8.7	1807	9.0	—	—	—	—	—	—
4250	1795	8.9	1861	9.3	—	—	—	—	—	—
4500	1856	9.3	1918	9.6	—	—	—	—	—	—
4750	1919	9.6	—	—	—	—	—	—	—	—
5000	—	—	—	—	—	—	—	—	—	—

Medium Static 1080-1918 rpm

Fan data (cont)

FHX120 High Static Fan Data (rpm - vdc)

CFM	AVAILABLE EXTERNAL STATIC PRESSURE (in. wg)									
	0.2		0.4		0.6		0.8		1.0	
	rpm	Vdc	rpm	Vdc	rpm	Vdc	rpm	Vdc	rpm	Vdc
3000	1080	4.8	1175	5.3	1268	5.7	1361	6.1	1453	6.6
3250	1154	5.2	1243	5.6	1329	6.0	1415	6.4	1501	6.8
3500	1229	5.5	1312	5.9	1393	6.3	1473	6.6	1553	7.0
3750	1305	5.9	1384	6.2	1459	6.6	1534	6.9	1609	7.3
4000	1381	6.2	1456	6.6	1527	6.9	1598	7.2	1668	7.5
4250	1458	6.6	1529	6.9	1597	7.2	1664	7.5	1730	7.8
4500	1535	6.9	1603	7.2	1668	7.5	1731	7.8	1794	8.1
4750	1613	7.3	1678	7.6	1740	7.9	1800	8.2	1860	8.4
5000	1691	7.7	1753	7.9	1813	8.2	1870	8.5	1927	8.7

CFM	AVAILABLE EXTERNAL STATIC PRESSURE (in. wg)									
	1.2		1.4		1.6		1.8		2.0	
	rpm	Vdc	rpm	Vdc	rpm	Vdc	rpm	Vdc	rpm	Vdc
3000	1543	7.0	1629	7.4	1712	7.7	1791	8.1	1866	8.5
3250	1586	7.2	1668	7.5	1748	7.9	1825	8.3	1899	8.6
3500	1632	7.4	1711	7.7	1787	8.1	1862	8.4	1935	8.8
3750	1683	7.6	1757	8.0	1830	8.3	1902	8.6	1972	8.9
4000	1738	7.9	1807	8.2	1877	8.5	1945	8.8	2013	9.1
4250	1795	8.1	1861	8.4	1927	8.7	1992	9.0	—	—
4500	1856	8.4	1918	8.7	1980	9.0	2042	9.3	—	—
4750	1919	8.7	1977	9.0	2036	9.2	—	—	—	—
5000	1983	9.0	2039	9.3	—	—	—	—	—	—

High Static 1080-2013 rpm

Fan data (cont)

Fan Performance Data — FHS, 0.0-1.2 in. wg ESP, 60 Hz — English^{a,b}

UNIT	AIRFLOW (cfm)	EXTERNAL STATIC PRESSURE (in. wg) ^c													
		0.0		0.2		0.4		0.6		0.8		1.0		1.2	
		Rpm	Bhp	Rpm	Bhp	Rpm	Bhp	Rpm	Bhp	Rpm	Bhp	Rpm	Bhp	Rpm	Bhp
FHS180	4,500	437	0.61	483	0.72	576	1.01	660	1.35	732	1.69	797	2.03	856	2.38
	5,300	499	0.95	538	1.07	617	1.37	696	1.74	767	2.13	830	2.53	888	2.94
	6,000	555	1.34	590	1.48	659	1.79	730	2.17	798	2.59	860	3.04	918	3.49
	6,800	620	1.91	651	2.06	712	2.39	774	2.78	836	3.22	896	3.71	952	4.21
	7,500	677	2.52	706	2.69	761	3.04	817	3.44	873	3.89	929	4.39	984	4.93
FHS240 ^d	6,000	542	1.29	577	1.42	646	1.72	716	2.09	785	2.51	849	2.95	907	3.40
	7,000	620	1.99	652	2.15	711	2.48	771	2.85	831	3.28	890	3.76	947	4.27
	8,000	700	2.92	728	3.10	781	3.46	833	3.85	885	4.29	938	4.78	990	5.32
	9,000	781	4.10	806	4.30	854	4.71	900	5.13	946	5.58	993	6.08	1039	6.62
	10,000	862	5.56	<u>885</u>	<u>5.79</u>	<u>929</u>	<u>6.24</u>	<u>971</u>	<u>6.70</u>	<u>1012</u>	<u>7.18</u>	<u>1054</u>	<u>7.69</u>	<u>1096</u>	<u>8.24</u>

Fan Performance Data — FHS, 1.4-2.4 in. wg ESP, 60 Hz — English^{a,b}

UNIT	AIRFLOW (cfm)	EXTERNAL STATIC PRESSURE (in. wg) ^c											
		1.4		1.6		1.8		2.0		2.2		2.4	
		Rpm	Bhp	Rpm	Bhp	Rpm	Bhp	Rpm	Bhp	Rpm	Bhp	Rpm	Bhp
FHS180	4,500	912	2.75	967	3.12	1019	3.52	1070	3.92	1120	4.35	1168	4.79
	5,300	942	3.34	992	3.76	1041	4.18	1088	4.61	1134	5.06	1179	5.52
	6,000	971	3.95	1020	4.40	1067	4.86	1112	5.33	1156	5.81	—	—
	6,800	1005	4.72	1054	5.23	1101	5.75	1145	6.27	1187	6.79	—	—
	7,500	1036	5.48	1084	6.04	1131	6.61	1174	7.17	—	—	—	—
FHS240 ^d	6,000	961	3.86	1011	4.31	1058	4.77	1104	5.24	1147	5.71	—	—
	7,000	1000	4.79	1050	5.32	1097	5.85	1142	6.38	1184	6.91	—	—
	8,000	1041	5.88	1090	6.47	1137	7.07	1181	7.67	—	—	—	—
	9,000	1086	7.21	1133	7.82	1178	8.47	—	—	—	—	—	—
	10,000	<u>1138</u>	<u>8.83</u>	<u>1180</u>	<u>9.46</u>	—	—	—	—	—	—	—	—

NOTE(S):

- a. Maximum allowable fan speed is 1200 rpm for all sizes.
- b. Fan performance is based on deductions for wet coil, clean 2 in. filters, and unit casing. See table below for factory-supplied filter pressure drop.
- c. **Bold** indicates field-supplied drive is required.
Plain type indicates standard motor and standard drive.
Underlining indicates a different motor and drive combination other than the standard motor and standard drive combination is required. Refer to fan motor and drive tables to complete selection.
- d. Maximum allowable fan speed for size 240 units is 1200 rpm.

Factory-Supplied Pressure Drop — English

UNIT	AIRFLOW (cfm)	PRESSURE DROP (in. wg)
FHS180	4,500	0.08
	6,000	0.12
	7,500	0.17
FHS240	6,000	0.12
	8,000	0.19
	10,000	0.26

LEGEND

- Bhp** — Brake Horsepower Input to Fan
- ESP** — External Static Pressure

Fan data (cont)

Fan Performance Data — FHS, 0-300 kPa ESP, 60 Hz — SI^{a,b}

UNIT	AIRFLOW (L/s)	EXTERNAL STATIC PRESSURE (Pa) ^c													
		0		50		100		150		200		250		300	
		r/s	kW	r/s	kW	r/s	kW	r/s	kW	r/s	kW	r/s	kW	r/s	kW
FHS180	2120	7.28	0.45	8.05	0.54	9.60	0.75	11.00	1.01	12.20	1.26	13.28	1.51	14.27	1.77
	2500	8.32	0.71	8.97	0.80	10.28	1.02	11.60	1.30	12.78	1.59	13.83	1.89	14.80	2.19
	2830	9.25	1.00	9.83	1.10	10.98	1.33	12.17	1.62	13.30	1.93	14.33	2.27	15.30	2.60
	3210	10.33	1.42	10.85	1.54	11.87	1.78	12.90	2.07	13.93	2.40	14.93	2.77	15.87	3.14
	3540	11.28	1.88	11.77	2.01	12.68	2.27	13.62	2.57	14.55	2.90	15.48	3.27	16.40	3.68
FHS240 ^d	2830	9.03	0.96	9.62	1.06	10.77	1.28	11.93	1.56	13.08	1.87	14.15	2.20	15.12	2.54
	3300	10.33	1.48	10.87	1.60	11.85	1.85	12.85	2.13	13.85	2.45	14.83	2.80	15.78	3.18
	3780	11.67	2.18	12.13	2.31	13.02	2.58	13.88	2.87	14.75	3.20	15.63	3.56	16.50	3.97
	4250	13.02	3.06	13.43	3.21	14.23	3.51	15.00	3.83	15.77	4.16	16.55	4.53	17.32	4.94
	4720	14.37	4.15	<u>14.75</u>	<u>4.32</u>	<u>15.48</u>	<u>4.65</u>	<u>16.18</u>	<u>5.00</u>	<u>16.87</u>	<u>5.35</u>	<u>17.57</u>	<u>5.73</u>	<u>18.27</u>	<u>6.14</u>

Fan Performance Data — FHS, 350-600 kPa ESP, 60 Hz — SI^{a,b}

UNIT	AIRFLOW (L/s)	EXTERNAL STATIC PRESSURE (Pa) ^c											
		350		400		450		500		550		600	
		r/s	kW	r/s	kW	r/s	kW	r/s	kW	r/s	kW	r/s	kW
FHS180	2120	15.20	2.05	16.12	2.33	16.98	2.62	17.83	2.92	18.67	3.24	19.47	3.57
	2500	15.70	2.49	16.53	2.80	17.35	3.12	18.13	3.44	18.90	3.77	19.65	4.12
	2830	16.18	2.95	17.00	3.28	17.78	3.62	18.53	3.97	19.27	4.33	—	—
	3210	16.75	3.52	17.57	3.90	18.35	4.29	19.08	4.68	19.78	5.06	—	—
	3540	17.27	4.09	18.07	4.50	18.85	4.93	19.57	5.35	—	—	—	—
FHS240 ^d	2830	16.02	2.88	16.85	3.21	17.63	3.56	18.40	3.91	19.12	4.26	—	—
	3300	16.67	3.57	17.50	3.97	18.28	4.36	19.03	4.76	19.73	5.15	—	—
	3780	17.35	4.38	18.17	4.82	18.95	5.27	19.68	5.72	—	—	—	—
	4250	18.10	5.38	18.88	5.83	19.63	6.32	—	—	—	—	—	—
	4720	<u>18.97</u>	<u>6.58</u>	<u>19.67</u>	<u>7.05</u>	—	—	—	—	—	—	—	—

NOTE(S):

- a. Maximum allowable fan speed is 20 r/s for all sizes.
- b. Fan performance is based on deductions for wet coil, clean 51 mm filters, and unit casing. See table below for factory-supplied filter pressure drop.
- c. **Bold** indicates field-supplied drive is required.
Plain type indicates standard motor and standard drive.
Underlining indicates a different motor and drive combination other than the standard motor and standard drive combination is required. Refer to fan motor and drive tables to complete selection.
- d. Maximum allowable fan speed for size 240 units is 20 r/s.

Factory-Supplied Pressure Drop — SI

UNIT	AIRFLOW (L/s)	PRESSURE DROP (Pa)
FHS180	2100	20
	2800	30
	3500	42
FHS240	2900	32
	3800	47
	4700	64

LEGEND

ESP — External Static Pressure

Electrical data

FHX Electrical Data — Two Speed Motors

UNIT ^{a,b,c}	NOMINAL V-PH-Hz ^d	IFM TYPE	UNIT VOLTAGE LIMITS		FAN MOTOR			POWER SUPPLY ^e	
			Min.	Max.	Hp	kW	FLA ^f (Full Load Amps)	Minimum Circuit Amps (MCA)	Maximum Overcurrent Protection (MOCP)
FHX072	208/230-3-60	MED	187	253	2.4	1.76	6.4/5.8	8/8	15/15
		HIGH	187	253	3.0	2.24	7.5/6.7	10/9	15/15
	460-3-60	MED	414	506	2.4	1.76	3.0	4	15
		HIGH	414	506	3.0	2.24	3.5	5	15
	575-3-60	MED	518	632	2.4	1.76	2.5	4	15
		HIGH	518	632	3.0	2.24	3.0	4	15
FHX091	208/230-3-60	MED	187	253	2.4	1.76	6.4/5.8	8/8	15/15
		HIGH	187	253	3.0	2.24	7.5/6.7	10/9	15/15
	460-3-60	MED	414	506	2.4	1.76	3.0	4	15
		HIGH	414	506	3.0	2.24	3.5	5	15
	575-3-60	MED	518	632	2.4	1.76	2.5	4	15
		HIGH	518	632	3.0	2.24	3.0	4	15
FHX120	208/230-3-60	MED	187	253	2.4	1.76	6.4/5.8	8/8	15/15
		HIGH	187	253	3.0	2.24	7.5/6.7	10/9	15/15
	460-3-60	MED	414	506	2.4	1.76	3.0	4	15
		HIGH	414	506	3.0	2.24	3.5	5	15
	575-3-60	MED	518	632	2.4	1.76	2.5	4	15
		HIGH	518	632	3.0	2.24	3.0	4	15

NOTE(S):

- a. Unbalanced 3-Phase Supply Voltage: Never operate a motor where a phase imbalance in supply voltage is greater than 2%. Use the formula in the example below to determine the percentage of voltage imbalance.
- b. Installation with Accessory Electric Heaters: Size the Field Power Wiring between the heater TB1 and the FHX indoor fan motor per NEC Article 430-28 (1) or (2) (depends on length of conduit between heater enclosure and FHX/FHS power entry location). Install wires in field-installed conduit.
- c. See Fan Contactor Coil Data table below.
- d. Motors are designed for satisfactory operation within 10% of normal voltage shown. Voltages should not exceed the limits shown in the Voltage Limits column.
- e. Minimum circuit amps (MCA) and maximum overcurrent protection (MOCP) values are calculated in accordance with the NEC Article 440.
- f. Motor FLA values are established in accordance with Underwriters Laboratories (UL) Standard 1995.

Formula Example:

$$\% \text{ Voltage Imbalance} = 100 \times \frac{\text{max voltage deviation from average voltage}}{\text{average voltage}}$$

Example: Supply voltage is 230-3-60

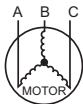

AB = 224 v
BC = 231 v
AC = 226 v

$$\text{Average Voltage} = \frac{(224 + 231 + 226)}{3} = \frac{681}{3} = 227$$

Determine maximum deviation from average voltage.

(AB) 227-224 = 3 v

(BC) 231-227 = 4 v

(AC) 227-226 = 1 v

Maximum deviation is 4 v.

Determine percent of voltage imbalance.

$$\% \text{ Voltage Imbalance} = 100 \times \frac{4}{227} = 1.78\%$$

This amount of phase imbalance is satisfactory as it is below the maximum allowable 2%.

IMPORTANT: If the supply voltage phase imbalance is more than 2%, contact your local electric utility company immediately.

Fan Contactor Coil Data

UNIT FHX	VOLTAGE (vac)	MAXIMUM HOLDING VA
072, 091, 120	24	10

Electrical data (cont)

FHS Electrical Data — Two Speed Motors

UNIT ^{a,b,c}	NOMINAL V-PH-Hz ^d	IFM TYPE	UNIT VOLTAGE LIMITS		FAN MOTOR			POWER SUPPLY ^e	
			Min.	Max.	Hp	kW	FLA ^f (Full Load Amps)	Minimum Circuit Amps (MCA)	Maximum Overcurrent Protection (MOCP)
FHS180	208/230-3-60	STD	187	253	3.7	2.76	10.8	14	20
		HIGH	187	253	5.0	3.73	18.0	23	40
	460-3-60	STD	414	506	3.7	2.76	4.9	7	15
		HIGH	414	506	5.0	3.73	9.1	12	20
	575-3-60	STD	518	632	3.7	2.76	4.5	6	15
		HIGH	518	632	5.0	3.73	8.0	10	15
FHS240	208/230-3-60	STD	187	253	5.0	3.73	18.0	23	40
		HIGH	187	253	7.5	5.60	23.5	30	50
	460-3-60	STD	414	506	5.0	3.73	9.1	12	20
		HIGH	414	506	7.5	5.60	15.0	19	30
	575-3-60	STD	518	632	5.0	3.73	8.0	10	15
		HIGH	518	632	7.5	5.60	10.0	13	20

NOTE(S):

- Unbalanced 3-Phase Supply Voltage: Never operate a motor where a phase imbalance in supply voltage is greater than 2%. Use the formula in the example below to determine the percentage of voltage imbalance.
- Installation with Accessory Electric Heaters: Size the Field Power Wiring between the heater TB1 and the FHX indoor fan motor per NEC Article 430-28 (1) or (2) (depends on length of conduit between heater enclosure and FHX/FHS power entry location). Install wires in field-installed conduit.
- See Fan Contactor Coil Data table below.
- Motors are designed for satisfactory operation within 10% of normal voltage shown. Voltages should not exceed the limits shown in the Voltage Limits column.
- Minimum circuit amps (MCA) and maximum overcurrent protection (MOCP) values are calculated in accordance with the NEC Article 440.
- Motor FLA values are established in accordance with Underwriters Laboratories (UL) Standard 1995.

Formula Example:

$$\% \text{ Voltage Imbalance} = 100 \times \frac{\text{max voltage deviation from average voltage}}{\text{average voltage}}$$

Example: Supply voltage is 230-3-60

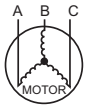

AB = 224 v
BC = 231 v
AC = 226 v

$$\text{Average Voltage} = \frac{(224 + 231 + 226)}{3} = \frac{681}{3} = 227$$

Determine maximum deviation from average voltage.

(AB) 227-224 = 3 v

(BC) 231-227 = 4 v

(AC) 227-226 = 1 v

Maximum deviation is 4 v.

Determine percent of voltage imbalance.

$$\% \text{ Voltage Imbalance} = 100 \times \frac{4}{227} = 1.78\%$$

This amount of phase imbalance is satisfactory as it is below the maximum allowable 2%.

IMPORTANT: If the supply voltage phase imbalance is more than 2%, contact your local electric utility company immediately.

Electrical data (cont)

Legend and Notes

Applicable Electrical Heater Data Tables on pages 35-37.

LEGEND

- FLA** — Full Load Amps
- MOCP** — Maximum Overcurrent Protection
- MCA** — Minimum Circuit Amps

NOTES:

1. Electrical resistance heaters are rated at 240-v, 480-v, or 575-v. To determine heater capacity (kW) at unit nameplate multiply the 240-v, 480-v, or 575-v capacity (kW) by the factor shown in the table below for the unit voltage.

HEATER RATING VOLTAGE	ACTUAL HEATER VOLTAGE										
	200	208	230	240	400	440	460	480	550	575	600
240	0.694	0.751	0.918	1	—	—	—	—	—	—	—
480	—	—	—	—	0.694	0.84	0.918	1	—	—	—
575	—	—	—	—	—	—	—	—	0.915	1	1.089

2. The following equation converts kW of heat energy to Btuh:
kW x 3,412 = Btuh.
3. Heater contactor coils are 24 v and require 8 va holding current.
4. Electric heaters are tested and UL approved at maximum total external static pressure of 1.9 in. wg.
5. MCA and MOCP values shown are for single-point connection of electric heat accessory and air handler.

FHX072-120, 60 Hz Electrical Heater Data

UNIT	NOMINAL VOLTS	IFM TYPE	UNIT VOLTAGE		FAN MOTOR (QTY 1)			ELECTRIC HEATER(S)						POWER SUPPLY			
			Range		Hp	kW	FLA	CAELHEAT ***00	Heater Voltage	Nom. Cap. (kW)	Actual Capacity (kW)			FLA	MCA	MOCP	
			Min	Max							Stage 1	Stage 2	Total				
FHX072	208/230	Med	187	253	2.4	1.76	6.4/5.8	050A	208/240	5	3.8/5.0	—	3.8/5.0	10.4/12.0	21.0/22.3	25/25	
			187	253	2.4	1.76	6.4/5.8	052A	208/240	10	7.5/10.0	—	7.5/10.0	20.8/24.1	34.0/37.4	35/40	
			187	253	2.4	1.76	6.4/5.8	055A	208/240	15	11.3/15.0	—	11.3/15.0	31.3/36.1	47.1/52.4	50/60	
			187	253	2.4	1.76	6.4/5.8	058A	208/240	25	11.3/15.0	7.5/10.0	18.8/25.0	52.1/60.1	73.1/82.4	80/90	
		High	187	253	3.0	2.24	7.5/6.7	050A	208/240	5	3.8/5.0	—	3.8/5.0	10.4/12.0	22.4/23.4	25/25	
			187	253	3.0	2.24	7.5/6.7	052A	208/240	10	7.5/10.0	—	7.5/10.0	20.8/24.1	35.4/38.5	40/40	
			187	253	3.0	2.24	7.5/6.7	055A	208/240	15	11.3/15.0	—	11.3/15.0	31.3/36.1	48.5/53.5	50/60	
			187	253	3.0	2.24	7.5/6.7	058A	208/240	25	11.3/15.0	7.5/10.0	18.8/25.0	52.1/60.1	74.5/83.5	80/90	
			460	Med	414	506	2.4	1.76	3.0	051A	480	5	5.0	—	5.0	6.0	11.3
	414	506	2.4		1.76	3.0	053A	480	10	10.0	—	10.0	12.0	18.8	20		
	414	506	2.4		1.76	3.0	056A	480	15	15.0	—	15.0	18.0	26.3	30		
	414	506	2.4		1.76	3.0	059A	480	25	15.0	10.0	25.0	30.1	41.4	50		
	High	414	506		3.0	2.24	3.5	051A	480	5	5.0	—	5.0	6.0	11.9	15	
		414	506		3.0	2.24	3.5	053A	480	10	10.0	—	10.0	12.0	19.4	20	
		414	506		3.0	2.24	3.5	056A	480	15	15.0	—	15.0	18.0	26.9	30	
		414	506		3.0	2.24	3.5	059A	480	25	15.0	10.0	25.0	30.1	42.0	50	
		575	Med		518	632	2.4	1.76	2.5	064A	575	5	5.0	—	5.0	4.8	9.1
	518	632		2.4	1.76	2.5	054A	575	10	10.0	—	10.0	9.6	15.1	20		
	518	632		2.4	1.76	2.5	057A	575	15	15.0	—	15.0	14.4	21.1	25		
	518	632		2.4	1.76	2.5	060A	575	25	15.0	10.0	25.0	24.1	33.3	35		
	High	518		632	3.0	2.24	3.0	064A	575	5	5.0	—	5.0	4.8	9.8	15	
		518		632	3.0	2.24	3.0	054A	575	10	10.0	—	10.0	9.6	15.8	20	
		518		632	3.0	2.24	3.0	057A	575	15	15.0	—	15.0	14.4	21.8	25	
		518		632	3.0	2.24	3.0	060A	575	25	15.0	10.0	25.0	24.1	33.9	35	
FHX091		208/230		Med	187	253	2.4	1.76	6.4/5.8	050A	208/240	5	3.8/5.0	—	3.8/5.0	10.4/12.0	21.0/22.3
	187		253		2.4	1.76	6.4/5.8	052A	208/240	10	7.5/10.0	—	7.5/10.0	20.8/24.1	34.0/37.4	35/40	
	187		253		2.4	1.76	6.4/5.8	055A	208/240	15	11.3/15.0	—	11.3/15.0	31.3/36.1	47.1/52.4	50/60	
	187		253		2.4	1.76	6.4/5.8	058A	208/240	25	11.3/15.0	7.5/10.0	18.8/25.0	52.1/60.1	73.1/82.4	80/90	
	High		187	253	2.4	1.76	6.4/5.8	061A	208/240	32	12.0/16.0	12.0/16.0	24.0/32.0	66.7/77.0	91.4/103.5	100/110	
			187	253	3.0	2.24	7.5/6.7	050A	208/240	5	3.8/5.0	—	3.8/5.0	10.4/12.0	22.4/23.4	25/25	
			187	253	3.0	2.24	7.5/6.7	052A	208/240	10	7.5/10.0	—	7.5/10.0	20.8/24.1	35.4/38.5	40/40	
			187	253	3.0	2.24	7.5/6.7	055A	208/240	15	11.3/15.0	—	11.3/15.0	31.3/36.1	48.5/53.5	50/60	
			187	253	3.0	2.24	7.5/6.7	058A	208/240	25	11.3/15.0	7.5/10.0	18.8/25.0	52.1/60.1	74.5/83.5	80/90	
	460	Med	187	253	3.0	2.24	7.5/6.7	061A	208/240	32	12.0/16.0	12.0/16.0	24.0/32.0	66.7/77.0	92.8/104.6	100/110	
			414	506	2.4	1.76	3.0	051A	480	5	5.0	—	5.0	6.0	11.3	15	
			414	506	2.4	1.76	3.0	053A	480	10	10.0	—	10.0	12.0	18.8	20	
			414	506	2.4	1.76	3.0	056A	480	15	15.0	—	15.0	18.0	26.3	30	
			414	506	2.4	1.76	3.0	059A	480	25	15.0	10.0	25.0	30.1	41.4	50	
			414	506	2.4	1.76	3.0	062A	480	35	20.0	15.0	35.0	42.1	56.4	60	
			High	414	506	3.0	2.24	3.5	051A	480	5	5.0	—	5.0	6.0	11.9	15
				414	506	3.0	2.24	3.5	053A	480	10	10.0	—	10.0	12.0	19.4	20
				414	506	3.0	2.24	3.5	056A	480	15	15.0	—	15.0	18.0	26.9	30
		414		506	3.0	2.24	3.5	059A	480	25	15.0	10.0	25.0	30.1	42.0	50	
		414		506	3.0	2.24	3.5	062A	480	35	20.0	15.0	35.0	42.1	57.0	60	

FHX072-120, 60 Hz Electrical Heater Data (cont)

UNIT	NOMINAL VOLTS	IFM TYPE	UNIT VOLTAGE		FAN MOTOR (QTY 1)			ELECTRIC HEATER(S)						POWER SUPPLY		
			Range		Hp	kW	FLA	CAELHEAT ****00	Heater Voltage	Nom. Cap. (kW)	Actual Capacity (kW)			FLA	MCA	MOCP
			Min	Max							Stage 1	Stage 2	Total			
FHX091 (cont)	575	Med	518	632	2.4	1.76	2.5	064A	575	5	5.0	—	5.0	4.8	9.1	15
			518	632	2.4	1.76	2.5	054A	575	10	10.0	—	10.0	9.6	15.1	20
			518	632	2.4	1.76	2.5	057A	575	15	15.0	—	15.0	14.4	21.1	25
			518	632	2.4	1.76	2.5	060A	575	25	15.0	10.0	25.0	24.1	33.3	35
			518	632	2.4	1.76	2.5	063A	575	35	20.0	15.0	35.0	33.7	45.3	50
		High	518	632	3.0	2.24	3.0	064A	575	5	5.0	—	5.0	4.8	9.8	15
			518	632	3.0	2.24	3.0	054A	575	10	10.0	—	10.0	9.6	15.8	20
			518	632	3.0	2.24	3.0	057A	575	15	15.0	—	15.0	14.4	21.8	25
			518	632	3.0	2.24	3.0	060A	575	25	15.0	10.0	25.0	24.1	33.9	35
			518	632	3.0	2.24	3.0	063A	575	35	20.0	15.0	35.0	33.7	45.9	50
FHX120	208/230	Med	187	253	2.4	1.76	6.4/5.8	050A	208/240	5	3.8/5.0	—	3.8/5.0	10.4/12.0	21.0/22.3	25/25
			187	253	2.4	1.76	6.4/5.8	052A	208/240	10	7.5/10.0	—	7.5/10.0	20.8/24.1	34.0/37.4	35/40
			187	253	2.4	1.76	6.4/5.8	055A	208/240	15	11.3/15.0	—	11.3/15.0	31.3/36.1	47.1/52.4	50/60
			187	253	2.4	1.76	6.4/5.8	058A	208/240	25	11.3/15.0	7.5/10.0	18.8/25.0	52.1/60.1	73.1/82.4	80/90
			187	253	2.4	1.76	6.4/5.8	061A	208/240	32	12.0/16.0	12.0/16.0	24.0/32.0	66.7/77.0	91.4/103.5	100/110
		High	187	253	3.0	2.24	7.5/6.7	050A	208/240	5	3.8/5.0	—	3.8/5.0	10.4/12.0	22.4/23.4	25/25
			187	253	3.0	2.24	7.5/6.7	052A	208/240	10	7.5/10.0	—	7.5/10.0	20.8/24.1	35.4/38.5	40/40
			187	253	3.0	2.24	7.5/6.7	055A	208/240	15	11.3/15.0	—	11.3/15.0	31.3/36.1	48.5/53.5	50/60
			187	253	3.0	2.24	7.5/6.7	058A	208/240	25	11.3/15.0	7.5/10.0	18.8/25.0	52.1/60.1	74.5/83.5	80/90
			187	253	3.0	2.24	7.5/6.7	061A	208/240	32	12.0/16.0	12.0/16.0	24.0/32.0	66.7/77.0	92.8/104.6	100/110
	460	Med	414	506	2.4	1.76	3.0	051A	480	5	5.0	—	5.0	6.0	11.3	15
			414	506	2.4	1.76	3.0	053A	480	10	10.0	—	10.0	12.0	18.8	20
			414	506	2.4	1.76	3.0	056A	480	15	15.0	—	15.0	18.0	26.3	30
			414	506	2.4	1.76	3.0	059A	480	25	15.0	10.0	25.0	30.1	41.4	50
			414	506	2.4	1.76	3.0	062A	480	35	20.0	15.0	35.0	42.1	56.4	60
		High	414	506	3.0	2.24	3.5	051A	480	5	5.0	—	5.0	6.0	11.9	15
			414	506	3.0	2.24	3.5	053A	480	10	10.0	—	10.0	12.0	19.4	20
			414	506	3.0	2.24	3.5	056A	480	15	15.0	—	15.0	18.0	26.9	30
			414	506	3.0	2.24	3.5	059A	480	25	15.0	10.0	25.0	30.1	42.0	50
			414	506	3.0	2.24	3.5	062A	480	35	20.0	15.0	35.0	42.1	57.0	60
575	Med	518	632	2.4	1.76	2.5	064A	575	5	5.0	—	5.0	4.8	9.1	15	
		518	632	2.4	1.76	2.5	054A	575	10	10.0	—	10.0	9.6	15.1	20	
		518	632	2.4	1.76	2.5	057A	575	15	15.0	—	15.0	14.4	21.1	25	
		518	632	2.4	1.76	2.5	060A	575	25	15.0	10.0	25.0	24.1	33.3	35	
		518	632	2.4	1.76	2.5	063A	575	35	20.0	15.0	35.0	33.7	45.3	50	
	High	518	632	3.0	2.24	3.0	064A	575	5	5.0	—	5.0	4.8	9.8	15	
		518	632	3.0	2.24	3.0	054A	575	10	10.0	—	10.0	9.6	15.8	20	
		518	632	3.0	2.24	3.0	057A	575	15	15.0	—	15.0	14.4	21.8	25	
		518	632	3.0	2.24	3.0	060A	575	25	15.0	10.0	25.0	24.1	33.9	35	
		518	632	3.0	2.24	3.0	063A	575	35	20.0	15.0	35.0	33.7	45.9	50	

See Legend and Notes on page 34.

Electrical data (cont)

FHS180/240, 60 Hz Electrical Heater Data

UNIT	NOM. VOLTS	IFM TYPE	UNIT VOLTAGE		FAN MOTOR (QTY 1)			ELECTRIC HEATER(S)						POWER SUPPLY			
			Range		Hp	kW	FLA	CAEL HEAT ****00	Heater Voltage	Nom. Cap. (kW)	Actual Capacity (kW)			FLA (Full Load Amps)	MCA (Min Ckt Amps)	MOCP (Max Overcurrent Protection)	
			Min	Max							Stage 1	Stage 2	Total				
FHS180	208/230	STD	187	253	3.7	2.76	10.8	016A	208/240	10	7.5/10	—	7.5/10	20.8/24.1	39.5/43.6	40/50	
			187	253	3.7	2.76	10.8	019A	208/240	20	15/20	—	15/20	41.7/48.1	65.6/73.6	70/80	
			187	253	3.7	2.76	10.8	022A	208/240	30	15/20	7.5/10	22.5/30	62.5/72.2	91.6/103.8	100/110	
			187	253	3.7	2.76	10.8	025A	208/240	50	22.6/30	15/20	37.6/50	104.2/120.3	143.8/163.9	150/175	
		HIGH	187	253	5.0	3.73	18.0	016A	208/240	10	7.5/10	—	7.5/10	20.8/24.1	48.5/52.6	50/60	
			187	253	5.0	3.73	18.0	019A	208/240	20	15/20	—	15/20	41.7/48.1	74.6/82.6	80/90	
			187	253	5.0	3.73	18.0	022A	208/240	30	15/20	7.5/10	22.5/30	62.5/72.2	100.6/112.8	110/125	
			187	253	5.0	3.73	18.0	025A	208/240	50	22.6/30	15/20	37.6/50	104.2/120.3	152.8/172.9	175/175	
	460	STD	414	506	3.7	2.76	4.9	017A	480	10	10	—	10	12	21.1	25	
			414	506	3.7	2.76	4.9	020A	480	20	20	—	20	23.9	36	40	
			414	506	3.7	2.76	4.9	023A	480	30	20	10	30	36.1	51.3	60	
			414	506	3.7	2.76	4.9	026A	480	50	30	20	50	60.1	81.3	90	
		HIGH	414	506	5.0	3.73	9.1	017A	480	10	10	—	10	12	26.4	30	
			414	506	5.0	3.73	9.1	020A	480	20	20	—	20	23.9	41.3	50	
			414	506	5.0	3.73	9.1	023A	480	30	20	10	30	36.1	56.5	60	
			414	506	5.0	3.73	9.1	026A	480	50	30	20	50	60.1	86.5	90	
	575	STD	518	632	3.7	2.76	4.5	018A	575	10	10	—	10	10	18.1	20	
			518	632	3.7	2.76	4.5	021A	575	20	20	—	20	20.1	30.8	35	
			518	632	3.7	2.76	4.5	024A	575	30	20	10	30	30.1	43.3	50	
			518	632	3.7	2.76	4.5	027A	575	50	30	20	50	50.2	68.4	70	
		HIGH	518	632	5.0	3.73	8.0	018A	575	10	10	—	10	10	22.5	25	
			518	632	5.0	3.73	8.0	021A	575	20	20	—	20	20.1	35.1	40	
			518	632	5.0	3.73	8.0	024A	575	30	20	10	30	30.1	47.6	50	
			518	632	5.0	3.73	8.0	027A	575	50	30	20	50	50.2	72.8	80	
	FHS240	208/230	STD	187	253	5.0	3.73	18.0	016A	208/240	10	7.5/10	—	7.5/10	20.8/24.1	48.5/52.6	50/60
				187	253	5.0	3.73	18.0	019A	208/240	20	15/20	—	15/20	41.7/48.1	74.6/82.6	80/90
				187	253	5.0	3.73	18.0	022A	208/240	30	15/20	7.5/10	22.5/30	62.5/72.2	100.6/112.8	110/125
				187	253	5.0	3.73	18.0	025A	208/240	50	22.6/30	15/20	37.6/50	104.2/120.3	152.8/172.9	175/175
HIGH			187	253	7.5	5.60	23.5	016A	208/240	10	7.5/10	—	7.5/10	20.8/24.1	55.4/59.5	60/60	
			187	253	7.5	5.60	23.5	019A	208/240	20	15/20	—	15/20	41.7/48.1	81.5/89.5	90/90	
			187	253	7.5	5.60	23.5	022A	208/240	30	15/20	7.5/10	22.5/30	62.5/72.2	107.5/119.6	110/125	
			187	253	7.5	5.60	23.5	025A	208/240	50	22.6/30	15/20	37.6/50	104.2/120.3	159.6/179.8	175/200	
460		STD	414	506	5.0	3.73	9.1	017A	480	10	10	—	10	12	26.4	30	
			414	506	5.0	3.73	9.1	020A	480	20	20	—	20	23.9	41.3	50	
			414	506	5.0	3.73	9.1	023A	480	30	20	10	30	36.1	56.5	60	
			414	506	5.0	3.73	9.1	026A	480	50	30	20	50	60.1	86.5	90	
		HIGH	414	506	7.5	5.60	15.0	017A	480	10	10	—	10	12	33.8	35	
			414	506	7.5	5.60	15.0	020A	480	20	20	—	20	23.9	48.6	50	
			414	506	7.5	5.60	15.0	023A	480	30	20	10	30	36.1	63.9	70	
			414	506	7.5	5.60	15.0	026A	480	50	30	20	50	60.1	93.9	100	
575		STD	518	632	5.0	3.73	8.0	018A	575	10	10	—	10	10	22.5	25	
			518	632	5.0	3.73	8.0	021A	575	20	20	—	20	20.1	35.1	40	
			518	632	5.0	3.73	8.0	024A	575	30	20	10	30	30.1	47.6	50	
			518	632	5.0	3.73	8.0	027A	575	50	30	20	50	50.2	72.8	80	
	HIGH	518	632	7.5	5.60	10.0	018A	575	10	10	—	10	10	25	25		
		518	632	7.5	5.60	10.0	021A	575	20	20	—	20	20.1	37.6	40		
		518	632	7.5	5.60	10.0	024A	575	30	20	10	30	30.1	50.1	60		
		518	632	7.5	5.60	10.0	027A	575	50	30	20	50	50.2	75.3	80		

See Legend and Notes on page 34.

Typical piping and wiring diagrams

Horizontal Installation — FHX/FHS

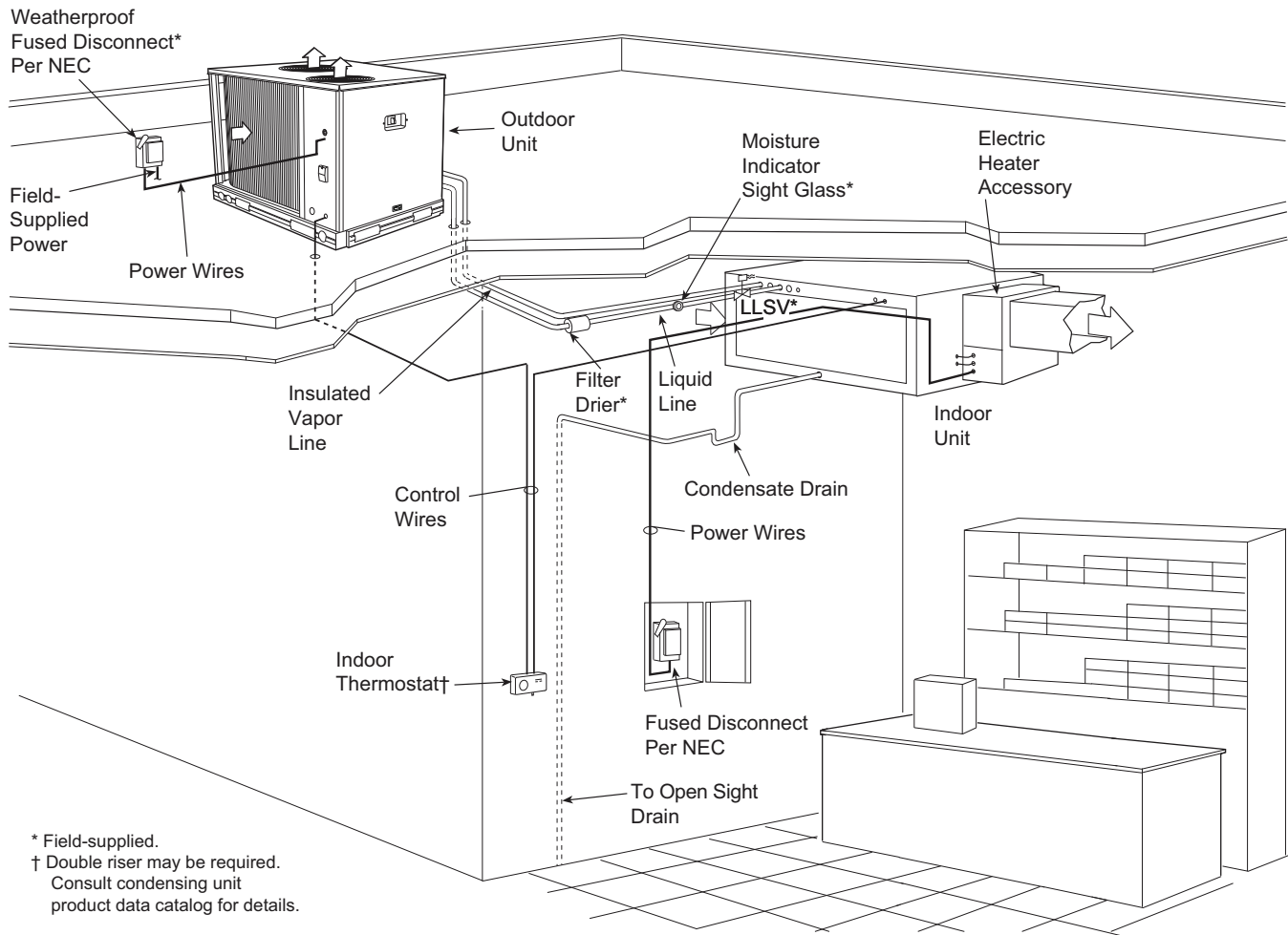

LEGEND

NEC — National Electrical Code
TXV — Thermostatic Expansion Valve

NOTES:

1. All piping must follow standard refrigerant piping techniques.
2. All wiring must comply with the applicable local and national codes.
3. Wiring and piping shown are general points-of-connection guides only and are not intended for, or to include all details for, a specific installation.
4. Liquid line solenoid valve (solenoid drop control) is recommended to prevent refrigerant migration to the compressor.
5. Internal factory-supplied TXVs not shown.

Typical piping and wiring diagrams (cont)

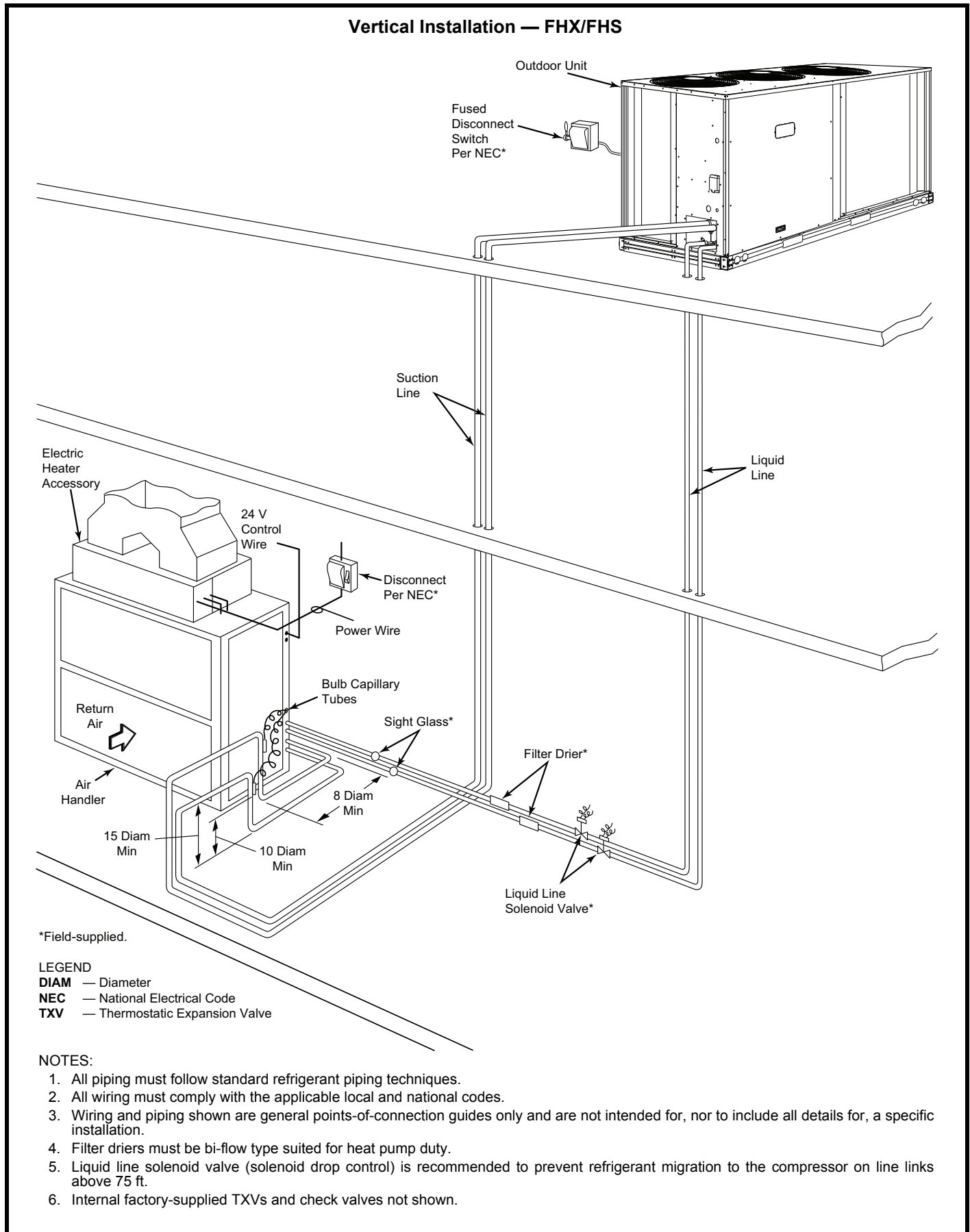

Typical piping and wiring diagrams (cont)

FHX Unit Wiring

NOTES:

1. TERMINAL BOARD SCHEMATIC LAYOUT DOES NOT MATCH ACTUAL TERMINAL BOARD LAYOUT.
2. REMOVE DESIGNATED JUMPERS ON TERMINAL BOARD WHEN ADDING SMOKE DETECTORS, OCCUPANCY AND REMOTE SHUTDOWN.
3. USE ABC AS COARSE AND POT AS FINE ADJUSTMENTS FOR SETTING HIGH FAN SPEED. LOW SPEED IS AN OFFSET BASED ON DIP SWITCHES.
4. 2-PIN LOW SPEED DIP SWITCH POSITIONS ARE FACTORY SET AS SHOWN.
5. TB2 LOCATED IN HEAT SECTION.
6. FREEZE PROTECTION SWITCH NORMALLY CLOSED. WILL OPEN WHEN THE EVAPORATOR COIL IS FROZEN.
7. WIRING SHOWN IS FOR 2 STAGE UNIT, TO CONVERT TO 3 STAGE UNIT:
 1. REMOVE GRA WIRE FROM T-STAT CB-X
 2. MOVE ORG WIRE FROM T-STAT CB-Y2 TO T-STAT CB-X
 3. BLU WIRE BETWEEN T-STAT CB-Y2 AND IDCB-Y2
 4. MOVE ORG WIRE FROM IDCB-Y2 TO IDCB-X

FIELD CONTROL WIRING

LEGEND

- FACTORY WIRING
- - - FIELD POWER WIRING
- · - ACCESSORY OR OPTIONAL WIRING
- CB CONNECTION BOARD
- FLS FAN LIMIT SWITCH
- FPR FREEZE PROTECTION RELAY
- FPT FREEZE PROTECTION THERMOSTAT
- IDCB INDOOR CONNECTION BOARD
- IFM INDOOR FAN MOTOR
- IFMC INDOOR FAN MOTOR CONTROL
- TB TERMINAL BLOCK

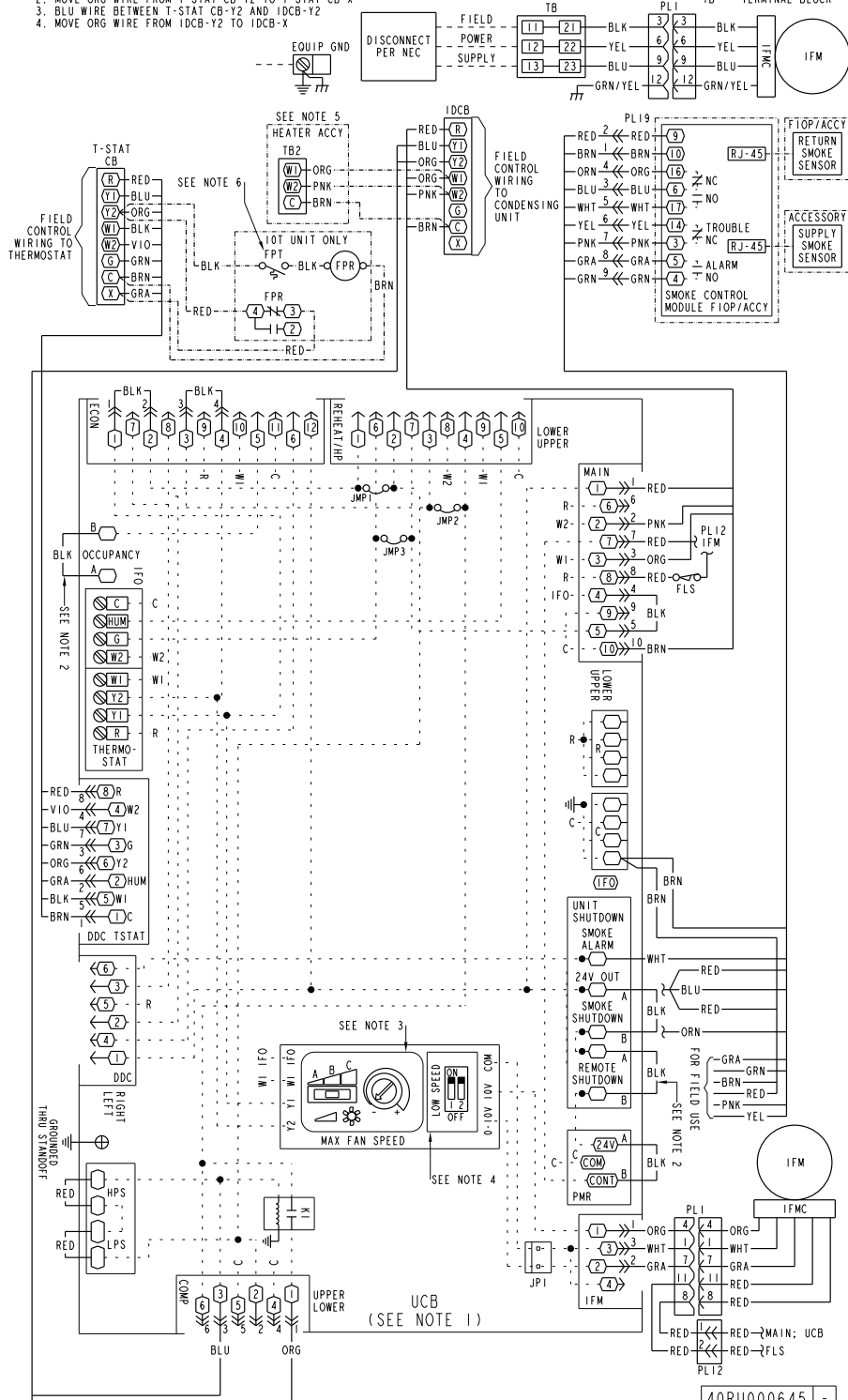

40RU000645 -

Typical piping and wiring diagrams (cont)

FHS Unit Wiring

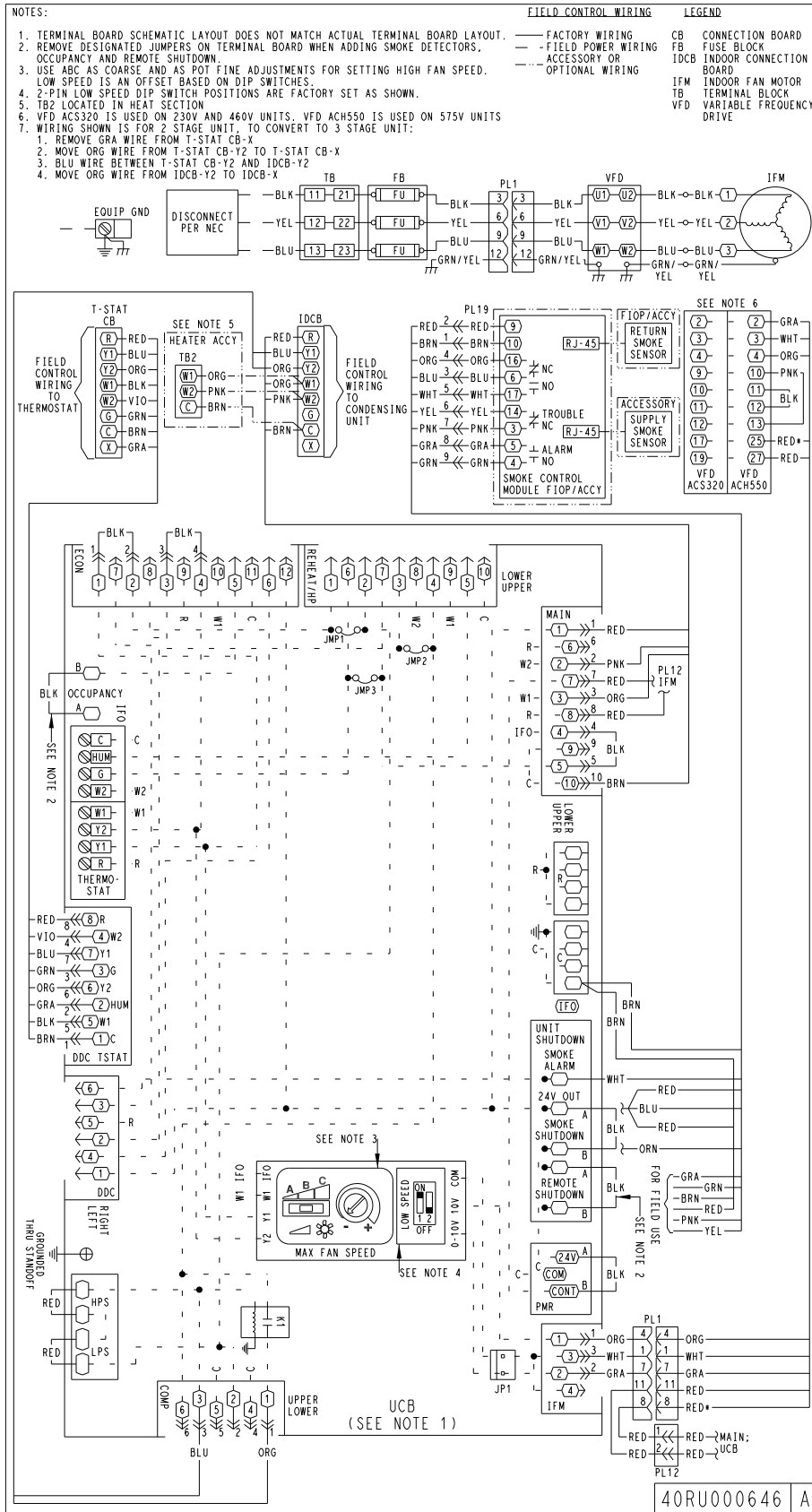

Application data

General

IMPORTANT: Do not bury refrigerant piping underground. Select equipment to match or to be slightly less than peak load. This provides better humidity control, less unit cycling, and less part-load operation. Equipment should be selected to perform at no less than 300 cfm/ton (40L/s per kW).

The air handler fan must always be operating when the condensing unit is operating.

Ductwork should be sized according to unit size, not building load. For larger units with two fans, a split duct transition is recommended at the fan outlets, but a plenum can be used with slight reduction in external static pressure capability.

Guide specifications — FHX

Split System Heat Pump Indoor Unit (Air-Handling Unit) with R-410A Refrigerant

HVAC Guide Specifications

Size Range: **2,400 to 3,000 cfm, Nominal Airflow**

6 to 10 Tons, Nominal Cooling

Model: **FHX072-120**

Part 1 — General

1.01 System Description

- A. Indoor, packaged air-handling unit for use in commercial heat pump split systems. Unit shall have a multi-position design and shall be capable of horizontal or vertical installation on a floor or in a ceiling, with or without ductwork. (Only vertical units are to be applied without ductwork.) Unit shall function as the indoor component of an air-to-air electric heat pump system.
- B. Unit must be designed with a R-410A refrigerant circuit with a matching air-cooled condensing unit CHS, for matched systems approved by the manufacturer.

1.02 Quality Assurance

- A. All coils shall be designed and tested in accordance with ASHRAE 15 Safety Code for Mechanical Refrigeration, latest edition.
- B. Unit shall be constructed in accordance with UL and UL, Canada, standards and shall carry the UL and UL, Canada, labels.
- C. Unit insulation and adhesive shall comply with NFPA-90A requirements for flame spread and smoke generation. Insulation shall be treated with an immobilized antimicrobial agent to inhibit the growth of bacteria and fungi on the insulation as proven by tests in accordance with ASTM standards G21 and 22 (U.S.A.).
- D. Unit shall be manufactured in a facility registered to the ISO 9001 manufacturing quality standard.
- E. Direct-expansion coils shall be leak tested at 150 psig and pressure tested at 650 psig and qualified to UL burst test at 1980 psig.

1.03 Delivery and Storage

- A. Units shall be stored and handled per manufacturer's recommendation.

Part 2 — Products

2.01 Equipment

- A. Base Unit: Indoor mounted, draw-thru, packaged air-handling unit that can be used in a suspended horizontal configuration or a vertical configuration. Unit shall consist of a direct drive vane axial fan and motor assembly, pre-wired fan motor controller, factory-installed refrigerant metering devices (direct-expansion coil units), cooling coil, 2 in. (51 mm) disposable air filters, and condensate drain pans for vertical or horizontal configurations.
 1. Cabinet shall be constructed of mill-galvanized steel.

2. Cabinet panels shall be fully insulated with 1/2 in. fire-retardant material. Insulation shall be treated with an immobilized antimicrobial agent to inhibit the growth of bacteria and fungi on the insulation as proven by tests in accordance with ASTM standards G21 and 22 (U.S.A.).

3. Unit shall contain corrosion-free condensate drain pans for both vertical and horizontal applications. Drain pans shall have connections on right and left sides of unit to facilitate field connection. Drain pans shall have the ability to be sloped toward the right or left side of the unit to prevent standing water from accumulating in pans.

4. Unit shall have factory-supplied 2 in. throw-away-type filters installed upstream from the cooling coil. Filter access shall be from either the right or left side of the unit.

B. Evaporator Fan and Motor with X-Vane Technology:

1. Direct Drive Evaporator fan motor:

- a. Shall be a ECM motor design.
- b. Shall have permanently lubricated bearings.
- c. Shall have inherent automatic-reset thermal overload protection.
- d. Shall have slow ramp up to speed capabilities.
- e. Shall require no fan/motor belts for operation, adjustments and or initial fan speed set up.
- f. Shall be internally protected from electrical phase reversal and loss.

2. Evaporator Fan:

- a. Shall be easily set with dedicated selection switch and adjustment pot on unit control board.
- b. Shall provide two stage cooling capacity control, the indoor fan speed is automatically controlled to meet the code-compliant <66% low fan speed and 100% at full fan speed operation.
- c. Blower fan shall be a Vane Axial fan design with 75% less moving parts than a conventional belt drive system.
- d. Shall be constructed of a high impact composite material on stator, rotor and air inlet casing.
- e. Shall be a patented / pending design with a corrosion resistant material and dynamically balanced.
- f. Shall have slow ramp up to speed capabilities to help reduce sound and comfort issues typically associated with single speed belt drive systems.
- g. Shall be a slide out design with removal of a few support brackets.

Guide specifications — FHX (cont)

3. Shall include an easily accessible Unit Control Board to conveniently and safely provide connection points for vital control functions such as: smoke detectors, phase monitor, economizer, thermostat, and low and high pressure switches. Controller shall also provide an intuitive means to adjust the indoor fan speed through a simple switch and pot adjustment design.
- C. Coils:
1. Coil is 4-row and consists of copper tubes with sine-wave aluminum fins bonded to the tubes by mechanical expansion. Suction and liquid line connections or supply and discharge connections shall be made on the same side of the coil.
 2. Coils shall feature factory-installed thermostatic expansion valves (TXVs) for refrigerant control. The TXVs shall be capable of external adjustment.
 3. Coils shall have a factory-installed bypass line and check valve assembly around the TXVs to allow liquid flow from the coil to the outdoor unit during heating mode.
- D. Operating Characteristics:
1. When combined with the matching CHS condensing unit the system shall be capable of starting and running up to 125°F (52°C) and down to 35°F (2°C) ambient outdoor temperature.
 2. Unit shall operate at ±10% from rated voltage.
- E. Motor:
1. Fan motor of the size and electrical characteristics specified on the equipment schedule shall be factory supplied and installed.
 2. Evaporator motors are designed specifically for our units and do not have conventional horsepower (hp) ratings listed on the motor nameplate. Motors are designed and qualified in the “air-over” location downstream of the cooling coil and carry a maximum continuous bhp rating that is the maximum application bhp rating for the motor; no “safety factors” above that rating may be applied.
- F. Special Features:
1. Alternate Motor and Drive:
An alternate high-static motor shall be available to meet the airflow and external static pressure requirements specified on the equipment schedule.
 2. External Paint Cabinet:
Where conditions require, units shall be painted with an American Sterling Gray finish.
 3. Hot Water Coil:
Coil shall be 2-row, U-bend coil with copper tubes and aluminum plate fins bonded to the tubes by mechanical expansion. Coil shall be mounted in a galvanized steel housing that shall be fastened to the unit's fan deck for blow-thru heating operation. Coil shall have maximum working pressure of 150 psig.
4. Steam Distributing Coil:
Coil shall consist of one row of copper tubes with aluminum plate fins, and shall have inner steam distributing tubes. Coil shall be mounted in a galvanized steel housing and shall be fastened to the unit's fan deck for blow-thru heating operation. Coil shall have maximum working pressure of 20 psig at 260°F.
5. Electric Heaters:
Heaters for nominal 240v, 480v, or 575v, 3-phase, 60 Hz power supply shall be factory-supplied and field-installed as shown on the equipment drawings. Electric heat assembly shall be ETL and ETL, Canada; agency approved, and shall have single-point power wiring. Heater assembly shall include contactors with 24v coils, power wiring, 24v control wiring terminal blocks, and a hinged access panel.
6. Air Discharge Plenum:
Plenum shall be factory-supplied to provide free-blow air distribution for vertical floor-mounted units. A grille with movable vanes for horizontal or vertical airflow adjustment shall be included. Plenum housing shall be field-installed on the unit's fan deck for blow-thru air distribution.
7. Return Air Grille:
Grille shall be factory-supplied for field installation on the unit's return air opening.
8. Unit Subbase:
Subbase assembly shall be factory-supplied for field installation. Subbase shall elevate floor-mounted vertical units to provide access for correct condensate drain connection.
9. Economizers:
- a. Accessory Ultra Low Leak EconoMiSer X. (Field installed):
Economizer for ventilation or “free” cooling shall be factory provided for field installation on either return air opening of air handler.
 - 1) Integrated, gear driven opposing modulating blade design type capable of simultaneous economizer and compressor operation.
 - 2) Damper blades shall be galvanized steel with composite gears. Plastic or composite blades on intake or return shall not be acceptable.
 - 3) Shall include all hardware, actuator and controls to provide free cooling with

Guide specifications — FHX (cont)

- outdoor air when temperature and/or humidity are below setpoints.
- 4) Shall be equipped with gear driven dampers for both the outdoor ventilation air and the return air for positive air stream control.
 - 5) Ultra LOW LEAK design meets California Title 24 section 140.4 and ASHRAE90.1 requirements for 4 cfm per sq ft on the outside air dampers and 10 cfm per sq ft on the return dampers.
 - 6) Economizer controller on EconoMi\$er X models shall be the Honeywell W7220 that provides:
 - a) 2-line LCD interface screen for setup, configuration and troubleshooting.
 - b) On-board Fault Detection and Diagnostics (FDD) that senses and alerts when the economizer is not operating properly, per California Title 24.
 - c) Sensor failure loss of communication identification.
 - d) Automatic sensor detection.
 - e) Capabilities for use with multiple-speed indoor fan systems.
 - f) Utilizing digital sensors: Dry bulb and Enthalpy. Accessory comes standard with dry bulb sensing.
 - g) Field installing enthalpy sensor required.
- b. Accessory Standard Leak EconoMi\$er IV (Field installed):
Economizer for ventilation or “free” cooling shall be factory provided for field installation on either return air opening of air handler.
- 1) Integrated, gear driven opposing modulating blade design type capable of simultaneous economizer and compressor operation.
 - 2) Damper blades shall be galvanized steel with composite gears. Plastic or composite blades on intake or return shall not be acceptable.
 - 3) Shall include all hardware, actuator and controls to provide free cooling with outdoor air when temperature and/or humidity are below setpoints.
- 4) Shall be equipped with gear driven dampers for both the outdoor ventilation air and the return air for positive air stream control.
 - 5) Standard leak rate shall be equipped with dampers not to exceed 2% leakage at 1 in. wg pressure differential.
 - 6) Economizer controller on EconoMi\$er IV models shall be Honeywell W7212 that provides:
 - a) Combined minimum and DCV maximum damper position potentiometers with compressor staging relay.
 - b) Functions with solid state analog enthalpy or dry bulb changeover control sensing.
 - c) Contains LED indicator for: when free cooling is available, when module is in DCV mode, when exhaust fan is closed.
10. Overhead Suspension Package:
Package shall include necessary brackets to support units in a horizontal ceiling installation.
11. CO₂ Sensor:
Sensor shall provide the ability to signal the economizer to open when the space CO₂ level exceeds the predetermined set point. Sensor shall have the capability of being connected to an economizer using field-supplied and field-installed Honeywell dc adapter no. Q769C1004.
12. Condensate Drain Trap:
Trap shall have transparent, serviceable design for easy cleaning. Kit shall also include overflow shutoff switch and wiring harness for connection to alarm if desired.
13. Discharge Duct Adapter
Adapter shall be required for replacements using FHX units with or without electric heat. It shall not be required for new installations or when using steam coil, hot water coil, or discharge plenum accessories.

Guide specifications — FHS

Split System Heat Pump Indoor Unit (Air-Handling Unit) with R-410A Refrigerant

HVAC Guide Specifications

Size Range: **6,000 to 8,000 cfm, Nominal Airflow**

15 to 20 Tons, Nominal Cooling

Model: **FHS180/240**

Part 1 — General

1.01 System Description

- A. Indoor, packaged air-handling unit for use in commercial heat pump split systems. Unit shall have a multi-position design and shall be capable of horizontal or vertical installation on a floor or in a ceiling, with or without ductwork. (Only vertical units are to be applied without ductwork.) Unit shall function as the indoor component of an air-to-air electric heat pump system.
- B. Unit must be designed with a R-410A refrigerant circuit with a matching air-cooled condensing unit CHS, for matched systems approved by the manufacturer.

1.02 Quality Assurance

- A. All coils shall be designed and tested in accordance with ASHRAE 15 Safety Code for Mechanical Refrigeration, latest edition.
- B. Unit shall be constructed in accordance with ETL and ETL, Canada, standards and shall carry the ETL and ETL, Canada, labels.
- C. Unit insulation and adhesive shall comply with NFPA-90A requirements for flame spread and smoke generation. Insulation shall be treated with an immobilized antimicrobial agent to inhibit the growth of bacteria and fungi on the insulation as proven by tests in accordance with ASTM standards G21 and 22 (U.S.A.).
- D. Unit shall be manufactured in a facility registered to the ISO 9001 manufacturing quality standard.
- E. Direct-expansion coils shall be leak tested at 150 psig and pressure tested at 650 psig and qualified to UL burst test at 1980 psig.

1.03 Delivery and Storage

- A. Units shall be stored and handled per manufacturer's recommendation.

Part 2 — Products

2.01 Equipment

- A. Indoor mounted, draw-thru, packaged air-handling unit that can be used in a suspended horizontal configuration or a vertical configuration. Unit shall consist of forward-curved belt-driven centrifugal fan(s), motor and drive assembly, pre-wired fan motor contactor, factory-installed refrigerant metering devices, cooling coil, 2 in. (51 mm) disposable air filters, and condensate drain pans for vertical or horizontal configurations.
 1. Cabinet shall be constructed of mill-galvanized steel.

2. Cabinet panels shall be fully insulated with 1/2 in. fire-retardant material. Insulation shall be treated with an immobilized antimicrobial agent to inhibit the growth of bacteria and fungi on the insulation as proven by tests in accordance with ASTM standards G21 and 22 (U.S.A.).
3. Unit shall contain corrosion-free condensate drain pans for both vertical and horizontal applications. Drain pans shall have connections on right and left sides of unit to facilitate field connection. Drain pans shall have the ability to be sloped toward the right or left side of the unit to prevent standing water from accumulating in pans.
4. Unit shall have factory-supplied 2 in. throw-away-type filters installed upstream from the cooling coil. Filter access shall be from either the right or left side of the unit.

B. Coils:

1. Coils shall consist of 4 rows of copper tubes with sine-wave aluminum fins bonded to the tubes by mechanical expansion. Refrigerant line connections shall be made on the same side of the coil.
2. Coils shall feature factory-installed thermostatic expansion valves (TXVs) for refrigerant control. The TXVs shall be capable of external adjustment.
3. Coils shall have a factory-installed bypass line and check valve assembly around the TXVs to allow liquid flow from the coil to the outdoor unit during heating mode.

C. Operating Characteristics:

1. When combined with the matching CHS condensing unit the system shall be capable of starting and running up to 125°F (52°C) and down to 35°F (2°C) ambient outdoor temperature.
2. Unit shall operate at ±10% from rated voltage.

D. Motor:

1. Fan motor of the size and electrical characteristics specified on the equipment schedule shall be factory-supplied and factory-installed.
2. Indoor-fan motor shall have permanently lubricated, sealed bearings and inherent automatic-reset thermal overload protection (motors smaller than 5 hp) or manual reset calibrated circuit breakers (motors equal or larger than 5 hp). Indoor motors are designed specifically for our units and do not have conventional horsepower (hp) ratings listed on the motor nameplate. Motors are designed and qualified in the "air-over" location downstream of the cooling coil and carry a maximum continuous bhp rating that is the maximum application bhp rating for the motors; no "safety factors" above that rating may be applied.

Guide specifications — FHS (cont)

3. All indoor fan motors 5 hp and larger shall meet the minimum efficiency requirements as established by the Energy Policy Act of 1992 (EPACT), effective October 24, 1997.
 4. High efficient motors listed shall meet section 313 of the Energy Independence and Security Act of 2007 (EISA 2007).
- E. Control Box:
1. Shall include an easily accessible Unit Control Board to conveniently and safely provide connection points for vital control functions such as: smoke detectors, phase monitor, economizer, thermostat, and low and high pressure switches. Controller shall also provide an intuitive means to adjust the indoor fan speed through a simple switch and pot adjustment design.
- F. 2-Speed Indoor Fan Motor system for 2-stage cooling models (standard):
1. Evaporator fan motor.
 - a. Shall have permanently lubricated bearings.
 - b. Shall have a maximum continuous bhp rating for continuous duty operation; no safety factors above that rating.
 - c. Shall be Variable Frequency duty and 2-speed control.
 - d. Shall contain motor shaft grounding ring to prevent electrical bearing fluting damage by safely diverting harmful shaft voltages and bearing currents to ground.
 2. Variable Frequency Drive (VFD) Standard:
 - a. Shall be installed inside the unit cabinet, mounted, wired and tested.
 - b. Shall contain Electromagnetic Interference (EMI) frequency protection.
 - c. Insulated Gate Bi-Polar Transistors (IGBT) used to produce the output pulse width modulated (PWM) wave-form, allowing for quiet motor operation.
 - d. Self diagnostics with fault and power code LED indicator. Field accessory Display Kit available for further diagnostics and special setup applications.
 - e. RS485 capability standard.
 - f. Electronic thermal overload protection.
 - g. 5% swinging chokes for harmonic reduction and improved power factor.
 - h. All printed circuit boards shall be conformal coated.
- G. Special Features:
1. Alternate Motor and Drive:

An alternate motor and medium or high-static drive shall be available to meet the airflow and external static pressure requirements specified on the equipment schedule.
2. External Paint Cabinet:

Where conditions require, units shall be painted with an American Sterling Gray finish.
 3. Hot Water Coil:

Coil shall be 2-row, U-bend coil with copper tubes and aluminum plate fins bonded to the tubes by mechanical expansion. Coil shall be mounted in a galvanized steel housing that shall be fastened to the unit's fan deck for blow-thru heating operation. Coil shall have maximum working pressure of 150 psig.
 4. Steam Distributing Coil:

Coil shall consist of one row of copper tubes with aluminum plate fins, and shall have inner steam distributing tubes. Coil shall be mounted in a galvanized steel housing and shall be fastened to the unit's fan deck for blow-thru heating operation. Coil shall have maximum working pressure of 20 psig at 260°F.
 5. Electric Heaters:

Heaters for nominal 240v, 480v, or 575v, 3-phase, 60 Hz power supply shall be factory-supplied and field-installed as shown on the equipment drawings. Electric heat assembly shall be ETL and ETL, Canada; agency approved, and shall have single-point power wiring. Heater assembly shall include contactors with 24v coils, power wiring, 24v control wiring terminal blocks, and a hinged access panel.
 6. Air Discharge Plenum:

Plenum shall be factory-supplied to provide free-blow air distribution for vertical floor-mounted units. A grille with movable vanes for horizontal or vertical airflow adjustment shall be included. Plenum housing shall be field-installed on the unit's fan deck for blow-thru air distribution.
 7. Return Air Grille:

Grille shall be factory-supplied for field installation on the unit's return air opening.
 8. Unit Subbase:

Subbase assembly shall be factory-supplied for field installation. Subbase shall elevate floor-mounted vertical units to provide access for correct condensate drain connection.
 9. Economizers:
 - a. Accessory Ultra Low Leak EconoMiSer X. (Field installed):

Economizer for ventilation or "free" cooling shall be factory provided for field installation on either return air opening of air handler.

 - 1) Integrated, gear driven opposing modulating blade design type capable of

Guide specifications — FHS (cont)

- simultaneous economizer and compressor operation.
- 2) Damper blades shall be galvanized steel with composite gears. Plastic or composite blades on intake or return shall not be acceptable.
 - 3) Shall include all hardware, actuator and controls to provide free cooling with outdoor air when temperature and/or humidity are below setpoints.
 - 4) Shall be equipped with gear driven dampers for both the outdoor ventilation air and the return air for positive air stream control.
 - 5) Ultra LOW LEAK design meets California Title 24 section 140.4 and ASHRAE90.1 requirements for 4 cfm per sq ft on the outside air dampers and 10 cfm per sq ft on the return dampers.
 - 6) Economizer controller on EconoMi\$er X models shall be the Honeywell W7220 that provides:
 - a) 2-line LCD interface screen for setup, configuration and troubleshooting.
 - b) On-board Fault Detection and Diagnostics (FDD) that senses and alerts when the economizer is not operating properly, per California Title 24.
 - c) Sensor failure loss of communication identification.
 - d) Automatic sensor detection.
 - e) Capabilities for use with multiple-speed indoor fan systems.
 - f) Utilizing digital sensors: Dry bulb and Enthalpy. Accessory comes standard with dry bulb sensing.
 - g) Field installing enthalpy sensor required.
- b. Accessory Standard Leak EconoMi\$er IV (Field installed):
- Economizer for ventilation or “free” cooling shall be factory provided for field installation on either return air opening of air handler.
- 1) Integrated, gear driven opposing modulating blade design type capable of simultaneous economizer and compressor operation.
 - 2) Damper blades shall be galvanized steel with composite gears. Plastic or composite blades on intake or return shall not be acceptable.
 - 3) Shall include all hardware, actuator and controls to provide free cooling with outdoor air when temperature and/or humidity are below setpoints.
 - 4) Shall be equipped with gear driven dampers for both the outdoor ventilation air and the return air for positive air stream control.
 - 5) Standard leak rate shall be equipped with dampers not to exceed 2% leakage at 1 in. wg pressure differential.
 - 6) Economizer controller on EconoMi\$er IV models shall be Honeywell W7212 that provides:
 - a) Combined minimum and DCV maximum damper position potentiometers with compressor staging relay.
 - b) Functions with solid state analog enthalpy or dry bulb changeover control sensing.
 - c) Contains LED indicates for: when free cooling is available, when module is in DCV mode, when exhaust fan is closed.
10. Overhead Suspension Package:

Package shall include necessary brackets to support units in a horizontal ceiling installation.
 11. CO₂ Sensor:

Sensor shall provide the ability to signal the economizer to open when the space CO₂ level exceeds the predetermined set point. Sensor shall have the capability of being connected to an economizer using field-supplied and field-installed Honeywell dc adapter no. Q769C1004.
 12. Condensate Drain Trap:

Trap shall have transparent, serviceable design for easy cleaning. Kit shall also include overflow shutoff switch and wiring harness for connection to alarm if desired.
 13. Display Kit for Variable Frequency Drive:
 - a. Kit allows the ability to access the VFD controller programs to provide special setup capabilities and diagnostics.
 - b. Kit contains display module and communications cable.
 - c. Display Kit can be permanently installed in the unit or used on any 2-Speed Indoor Fan Motor system VFD controller as needed.