

FUJITSU



FO*14R*F SERIES

Efficiencies up to 14.5 SEER/12.0 EER
Nominal Sizes 1 1/2 to 5 Ton [5.28 to 17.6 kW]
Cooling Capacities 17.3 to 60.5 kBtu
[5.7 to 17.7 kW]

Manufactured for
Fujitsu General America, Inc.
Fairfield, NJ

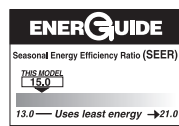

HEAT PUMP

Features

- The FO*14R*F series is designed to achieve 14 SEER with Coil only (for the dual fuel market) and PSC Air Handlers match ups.
- New composite base pan – dampens sound, captures louver panels, eliminates corrosion and reduces number of fasteners needed
- Improved tubing design – reduces vibration and stress, making unit quieter and reducing opportunity for leaks
- Optimized defrost characteristics - decrease defrosting and provide better home comfort
- Powder coat paint system – for a long lasting professional finish
- Optimized reversing valve sizing – improves shifting performance for quieter unit operation and increased life of the system
- Enhanced mufflers – help to dissipate vibration energy for quieter unit operation
- Scroll compressor – a sound abating feature added to the compressor significantly reduces noise when system transitions in and out of defrost mode
- Modern cabinet aesthetics – increased curb appeal with visually appealing design
- Curved louver panels – provide ultimate coil protection, enhance cabinet strength, and increased cabinet rigidity
- Optimized fan orifice – optimizes airflow and reduces unit sound
- Rust resistant screws – confirmed through 1500-hour salt spray testing
- **Expanded Valve Space** – 3"-4"-5" service valve space – provides a minimum working area of 27-square inches for easier access
- Integrated heat pump lift receptacle – allows standard CPVC stands to be inserted into the base
- **Triple Service Access** – 15" wide, industry leading corner service access – makes repairs easier and faster. The two fastener removable corner allows optimal access to internal unit components. Individual louver panels come out once fastener is removed, for faster coil cleaning and easier cabinet reassembly
- Diagnostic service window with two-fastener opening – provides access to the TXV valves and the heat pump reversing valve before opening the unit.
- External gauge port access – allows easy connection of "low-loss" gauge ports
- Single-row condenser coil – makes unit lighter and allows thorough coil cleaning to maintain "out of the box" performance
- 35% fewer cabinet fasteners and fastener-free base – allow for faster access to internal components and hassle-free panel removal
- Service trays – hold fasteners or caps during service calls
- QR code – provides technical information on demand for faster service calls
- Fan motor harness with extra-long wires – allows unit top to be removed without disconnecting fan wire

"Proper sizing and installation of equipment is critical to achieve optimal performance. Split system air conditioners and heat pumps must be matched with appropriate coil components to meet Energy Star. Ask your Contractor for details or visit www.energystar.gov."

TABLE OF CONTENTS

Model Number Identification	3
Available SKUs	3
Physical Data	4
Electrical Data	4
Accessories	5
Weighted Sound Power	5
Unit Dimensions.....	6
Clearances.....	7
Wiring Diagrams	8
Application Guidelines	8
Refrigerant Line Size Information	9-12
Performance Data	13
Guide Specifications	14
Limited Warranty	15

Model Number Identification

<u>FO</u>	<u>18</u>	<u>14</u>	<u>R</u>	<u>S</u>	<u>J</u>	<u>N</u>	<u>A</u>	<u>F</u>
Brand	Capacity	SEER	Product	Type	Voltage	Controls	Minor Series	Major Series
FO - Fujitsu	18 - 18,000 24 - 24,000 30 - 30,000 36 - 36,000 42 - 42,000 48 - 48,000 60 - 60,000	14 - 14 SEER	R - Heat Pump	S - Single Stage	J - 1ph, 208-230/60 C - 3ph, 208-230/60	N - Non-Communicating	A - First Design Series	F - Dual Fuel G - Dual Fuel Second Design Series

Available SKUs

Available Models
F01814RSJNAG
F02414RSJNAF
F03014RSJNAF
F03614RSCNAF
F03614RSJNAF
F04214RSCNAF
F04214RSJNAF
F04814RSCNAF
F04814RSJNAF
F06014RSCNAF
F06014RSJNAF

Physical Data							
Model No. #	F01814*G	F02414*F	F03014*F	F03614*F	F04214*F	F04814*F	F06014*F
Nominal Tonnage	1.5	2.0	2.5	3.0	3.5	4.0	5.0
Valve Connections							
Liquid Line O.D. – in.	3/8	3/8	3/8	3/8	3/8	3/8	3/8
Suction Line O.D. – in.	3/4	3/4	3/4	3/4	7/8	7/8	7/8
Refrigerant (R410A) furnished oz.¹	123	105	116	118	139	108	217
Compressor Type	Scroll						
Outdoor Coil							
Net face area – Outer Coil	11.1	11.1	17.3	19.8	19.8	24.2	28.3
Net face area – Inner Coil	—	—	—	—	—	—	—
Tube diameter – in.	3/8	3/8	3/8	3/8	3/8	3/8	3/8
Number of rows	1	1	1	1	1	1	1
Fins per inch	20	20	20	20	20	20	20
Outdoor Fan							
Diameter – in.	20	20	24	24	24	26	26
Number of blades	2	3	3	3	3	3	3
Motor hp	1/8	1/8	1/5	1/3	1/5	1/3	1/5
CFM	2478	2478	3852	3120	3815	4380	3655
RPM	1077	1075	825	910	825	870	850
watts	151	138	197	135	202	266	274
Shipping weight – lbs.	159	159	167	179	187	215	243
Operating weight – lbs.	152	152	160	172	180	208	236

Electrical Data							
Line Voltage Data (Volts-Phase-Hz)	208/230-1-60	208/230-1-60	208/230-1-60	208/230-1-60	208/230-1-60	208/230-1-60	208/230-1-60
Maximum overcurrent protection (amps)²	20/20	25	25	35	40	40	50
Minimum circuit ampacity³	12/12	15	18	23	24	26	31
Compressor							
Rated load amps	9/9	10.9	12.8	15.4	17.9	18.5	23.7
Locked rotor amps	48.0	62.9	67.8	83.9	112	124	152.5
Condenser Fan Motor							
Full load amps	0.75	0.7	1	2.8	1	2.8	1
Locked rotor amps	1.2	1.3	1.2	—	1.2	—	2.3
Line Voltage Data (Volts-Phase-Hz)	—	—	—	208/230-3-60	208/230-3-60	208/230-3-60	208/230-3-60
Maximum overcurrent protection (amps) ²	—	—	—	25	30	30	35
Minimum circuit ampacity ³	—	—	—	16	18	21	21
Compressor							
Rated load amps	—	—	—	10.4	13.5	13.8	15.9
Locked rotor amps	—	—	—	73	88	83.1	110

¹Refrigerant charge sufficient for 15 ft. length of refrigerant lines. For longer line set requirements see the installation instructions for information about set length and additional refrigerant charge required.

²HACR type circuit breaker or fuse.

³Refer to National Electrical Code manual to determine wire, fuse and disconnect size requirements.

Accessories

Model No.		F01814*G	F02414*F	F03014*F	F03614*F	F04214*F	F04814*F	F06014*F
Compressor crankcase heater		44-17402-44	44-17402-44	44-17402-44	44-17402-44	44-17402-45	Factory Standard	Factory Standard
Low ambient control		RXAD-A08	RXAD-A08	RXAD-A08	RXAD-A08	RXAD-A08	RXAD-A08	RXAD-A08
Compressor sound cover		68-23427-26	68-23427-26	68-23427-26	68-23427-26	68-23427-25	68-23427-25	68-23427-25
Compressor hard start kit		SK-A1	SK-A1	SK-A1	SK-A1	SK-A1	SK-A1	SK-A1
Low pressure control*		Factory Standard	Factory Standard	Factory Standard	Factory Standard	Factory Standard	Factory Standard	Factory Standard
High pressure control*		Factory Standard	Factory Standard	Factory Standard	Factory Standard	Factory Standard	Factory Standard	Factory Standard
Liquid Line Solenoid (24 VAC, 50/60 Hz)	Solenoid Valve	200RD2T3TVLC	200RD2T3TVLC	200RD2T3TVLC	200RD2T3TVLC	200RD2T3TVLC	200RD3T3TVLC	200RD3T3TVLC
	Solenoid Coil	61-AMG24V	61-AMG24V	61-AMG24V	61-AMG24V	61-AMG24V	61-AMG24V	61-AMG24V
	Bi-flow kit*	KS30387	KS30387	KS30387	KS30387	KS30387	KS30387	KS30387
Liquid Line Solenoid (120/240 VAC, 50/60 Hz)	Solenoid Valve	200RD2T3TVLC	200RD2T3TVLC	200RD2T3TVLC	200RD2T3TVLC	200RD2T3TVLC	200RD3T3TVLC	200RD3T3TVLC
	Solenoid Coil	61-AMG120/240V	61-AMG120/240V	61-AMG120/240V	61-AMG120/240V	61-AMG120/240V	61-AMG120/240V	61-AMG120/240V
	Bi-flow kit*	KS30387	KS30387	KS30387	KS30387	KS30387	KS30387	KS30387
Classic Top Cap w/Label		91-101123-21	91-101123-21	91-101123-21	91-101123-21	91-101123-21	91-101123-21	91-101123-21
Heat Pump Riser – 6 inch		686020	686020	686020	686020	686020	686020	686020

*Bi-flow kits are required when installing a liquid line solenoid on a heat pump.

Weighted Sound Power Level (dBA)

Unit Size – Voltage, Series	Standard Rating (dBA)	TYPICAL OCTAVE BAND SPECTRUM (dBA without tone adjustment)						
		125	250	500	1000	2000	4000	8000
F01814*G	76.4	53.7	61.8	66.2	66.8	62.9	58	52
F02414*F	75.8	53.9	60.6	65.8	66.4	63.0	57.8	50.2
F03014*F	73.3	51.8	56.6	63.4	62.9	60.8	55.9	51.5
F03614*F	74.7	48.9	54.3	63.1	66.4	62.2	53.2	53.2
F04214*F	74.1	52.9	55.9	64	63.5	61.4	58	52.1
F04814*F	76.5	55.8	59	68.2	66.3	64.3	60.5	55.4
F06014*F	73.9	58.9	55.7	63.4	63.3	61.5	58.6	56.4

NOTE: Tested in accordance with AHRI Standard 270-08 (not listed in AHRI)

Unit Dimensions

MODEL NUMBER	OPERATING						SHIPPING					
	H (Height)		L (Length)		W (Width)		H (Height)		L (Length)		W (Width)	
	INCHES	mm	INCHES	mm	INCHES	mm	INCHES	mm	INCHES	mm	INCHES	mm
F01814*F	25	635	29.75	755	29.75	755	26.75	673	32.38	822	32.38	822
F02414*F	25	635	29.75	755	29.75	755	26.75	679	32.38	822	32.38	822
F03014*F	31	787	33.75	857	33.75	857	32.75	831	32.38	822	32.38	822
F03614*F	35	889	33.75	857	33.75	857	36.75	933	36.38	924	36.38	924
F04214*F	35	889	33.75	857	33.75	857	36.75	933	36.38	924	36.38	924
F04814*F	39	990	35.75	908	35.75	908	40.75	1035	38.38	974	38.38	974
F06014*F	45	1143	35.75	908	35.75	908	46.75	1187	38.38	974	38.38	974

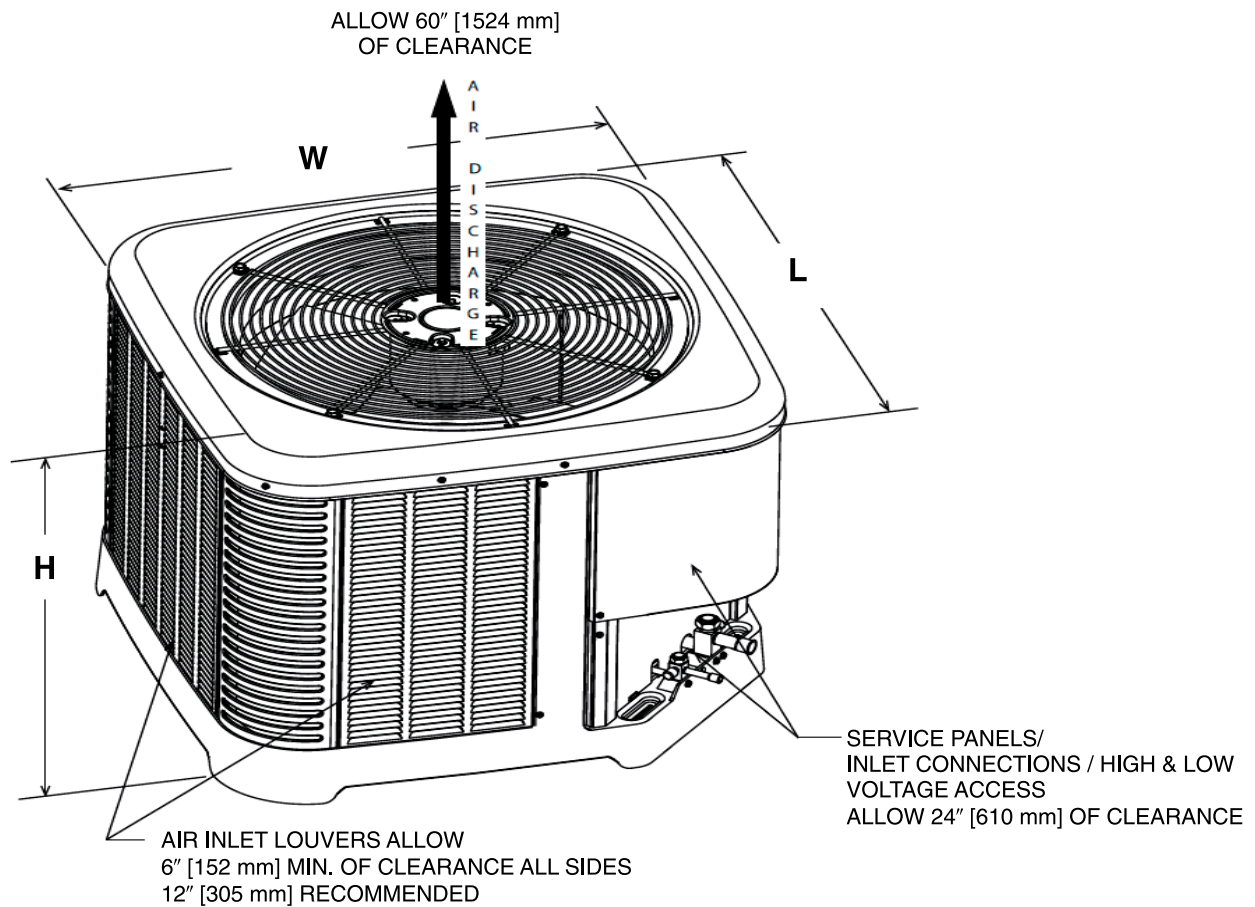

[] Designates Metric Conversions

ST-A1226-02-00

CLEARANCES

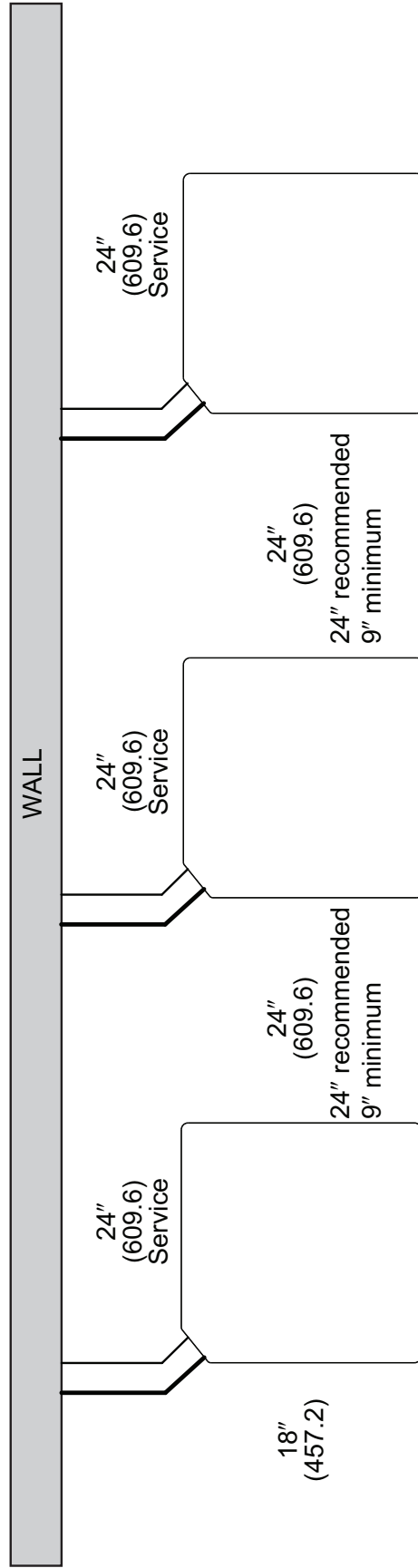
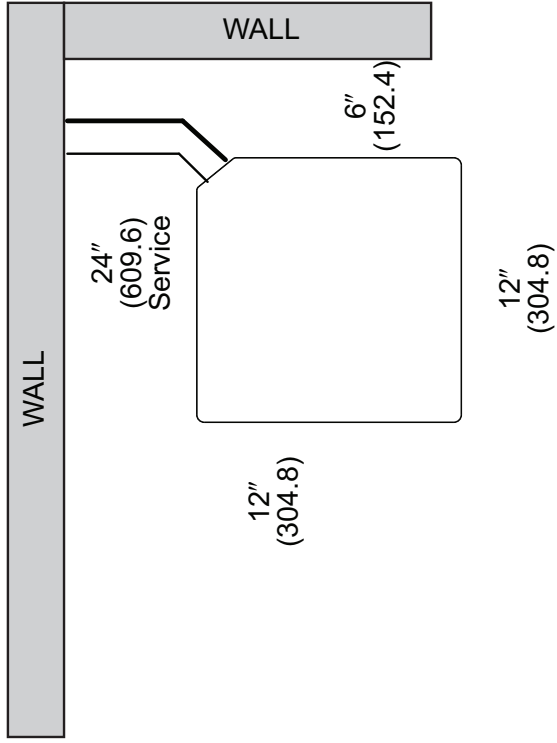
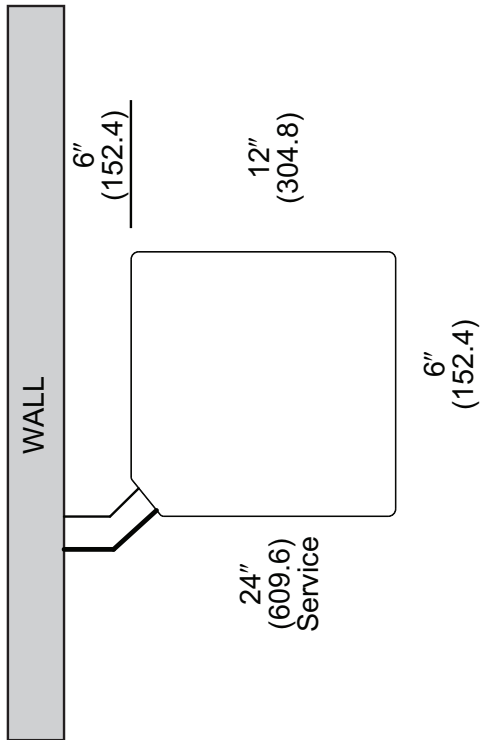

NOTE: NUMBERS IN () = mm

IMPORTANT: When installing multiple units in an alcove, roof well or partially enclosed area, ensure there is adequate ventilation to prevent re-circulation of discharge air.

Control Wiring

FIGURE 4
CONTROL WIRING FOR AIR HANDLER

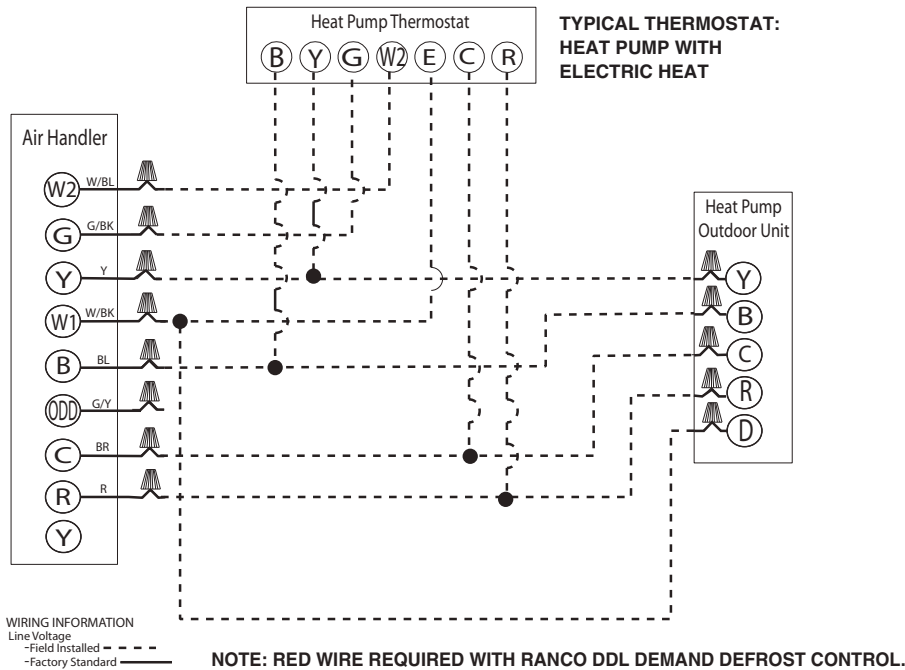

NOTES:

1. Jumper "E" to "W2" to transfer control of supplemental heat to 1st stage when the emergency heat switch is on.
2. This wire turns on heat for defrost, omit for most economical operation.
3. Wire with colored tracing stripe.

Application Guidelines

1. Intended for outdoor installation with free air inlet and outlet. Outdoor fan external static pressure available is less than 0.01 -in. wc.
2. Minimum outdoor operation air temperature for cooling mode without low-ambient operation accessory is 55°F (12.8°C).
3. Maximum outdoor operating air temperature is 125°F (51.7°C).
4. For reliable operation, unit should be level in all horizontal planes.
5. Use only copper wire for electric connections at unit. Aluminum and clad aluminum are not acceptable for the type of connector provided.
6. Do not apply capillary tube indoor coils to these units.
7. Factory – supplied filter drier must be installed.

Refrigerant Line Sizing Chart (English Units)

14 SEER Single-Stage Heat Pumps														
Unit Size	Allowable Liquid Line Size	Allowable Vapor Line Size	Apply Long Line Guidelines if Linear Line Length Exceeds Those Shown Below (Feet) (-)P14-F	Outdoor Unit ABOVE or BELOW Indoor Unit Equivalent Length (Feet)										
				< 25	26-50	51-75	76-100	101-125	126-150	151-175	176-200	201-225	226-250	
				Maximum Vertical Separation / Capacity Multiplier										
1.5 Ton* SEE NOTE 3	1/4"	5/8"	98	25/1.00	50/0.99	62/0.98	43/0.98	24/0.97	5/0.97	N/R	N/R	N/R	N/R	N/R
	5/16"	5/8"	78	25/1.00	50/0.99	75/0.98	98/0.98	93/0.97	88/0.97	83/0.96	78/0.96	73/0.95	68/0.94	
	3/8"	5/8"	57	25/1.00	50/0.99	75/0.98	100/0.98	100/0.97	100/0.97	100/0.96	100/0.96	100/0.95	100/0.94	
	1/4"	3/4**	98	25/1.00	50/1.00	62/0.99	43/0.99	24/0.99	5/0.99	N/R	N/R	N/R	N/R	
	5/16"	3/4**	78	25/1.00	50/1.00	75/0.99	98/0.99	93/0.99	88/0.99	83/0.99	78/0.98	73/0.98	68/0.98	
	3/8"	3/4**	57	25/1.00	50/1.00	75/1.00	100/0.99	100/0.99	100/0.99	100/0.99	100/0.98	100/0.98	100/0.98	
2 Ton	1/4"	5/8"	N/A	25/0.99	50/0.98	21/0.97	N/R	N/R	N/R	N/R	N/R	N/R	N/R	
	5/16"	5/8"	123	25/0.99	50/0.98	75/0.97	87/0.96	77/0.95	69/0.94	61/0.93	53/0.92	45/0.91	37/0.90	
	3/8"	5/8"	82	25/0.99	50/0.98	75/0.97	100/0.96	100/0.95	100/0.94	98/0.93	95/0.92	93/0.91	90/0.90	
	1/4"	3/4"	N/A	25/1.00	50/1.00	21/0.99	N/R	N/R	N/R	N/R	N/R	N/R	N/R	
	5/16"	3/4"	123	25/1.00	50/1.00	75/0.99	87/0.99	77/0.98	69/0.98	61/0.98	53/0.97	45/0.97	37/0.96	
	3/8"	3/4"	82	25/1.00	50/1.00	75/0.99	100/0.99	100/0.99	100/0.98	98/0.98	95/0.97	93/0.97	90/0.96	
2.5 Ton	5/16"	5/8"	103	25/0.99	50/0.98	75/0.96	70/0.94	59/0.93	48/0.91	36/0.90	N/R	N/R	N/R	
	3/8"	5/8"	68	25/0.99	50/0.98	75/0.96	100/0.94	98/0.93	94/0.91	90/0.90	N/R	N/R	N/R	
	5/16"	3/4"	103	25/1.00	50/0.99	75/0.99	70/0.98	59/0.98	48/0.97	36/0.96	25/0.96	13/0.95	N/R	
	3/8"	3/4"	68	25/1.00	50/0.99	75/0.99	100/0.98	98/0.98	94/0.97	90/0.96	86/0.96	82/0.95	78/0.95	
	5/16"	5/8"	98	25/0.99	50/0.97	66/0.94	49/0.92	32/0.90	N/R	N/R	N/R	N/R	N/R	
	3/8"	5/8"	65	25/0.99	50/0.97	75/0.94	95/0.92	89/0.90	N/R	N/R	N/R	N/R	N/R	
3 Ton	5/16"	3/4"	98	25/1.00	50/0.99	66/0.98	49/0.98	32/0.97	15/0.96	N/R	N/R	N/R	N/R	
	3/8"	3/4"	65	25/1.00	50/0.99	75/0.98	95/0.98	89/0.97	84/0.96	78/0.95	72/0.94	67/0.93	61/0.93	
	1/2"	3/4"	33	25/1.00	50/0.99	75/0.98	100/0.98	100/0.97	100/0.96	100/0.95	100/0.94	100/0.93	100/0.93	
	5/16"	7/8"	98	25/1.00	50/1.00	66/1.00	49/0.99	32/0.99	15/0.99	N/R	N/R	N/R	N/R	
	3/8"	7/8"	65	25/1.00	50/1.00	75/1.00	95/0.99	89/0.99	84/0.99	84/0.99	78/0.98	67/0.98	61/0.97	
	1/2"	7/8"	33	25/1.00	50/1.00	75/1.00	100/0.99	100/0.99	100/0.99	100/0.98	100/0.98	100/0.98	100/0.97	
3.5 Ton	3/8"	3/4"	93	25/0.99	50/0.98	75/0.97	88/0.96	80/0.95	72/0.94	65/0.92	57/0.91	49/0.90	N/R	
	1/2"	3/4"	47	25/0.99	50/0.98	75/0.97	100/0.96	100/0.95	100/0.94	100/0.92	100/0.91	100/0.90	N/R	
	3/8"	7/8"	93	25/1.00	50/1.00	75/0.99	88/0.99	80/0.99	72/0.98	65/0.97	57/0.97	49/0.96	42/0.96	
	1/2"	7/8"	47	25/1.00	50/1.00	75/0.99	100/0.99	100/0.99	100/0.99	100/0.98	100/0.97	100/0.96	100/0.96	

Notes:
 1) Do not exceed 200 ft linear line length.
 2) Do not exceed 100 ft vertical separation between indoor and outdoor units.
 3) *3/4" vapor line should only be used for 1.5 ton systems if outdoor unit is below or at same level as indoor unit to assure proper oil return.
 4) Always use the smallest liquid line allowable to minimize refrigerant charge.
 5) Applications shaded in light gray indicate capacity multipliers between 0.90 and 0.96 which are not recommended, but are allowed.
 6) Applications shaded in dark gray are not recommended due to excessive liquid or suction line pressure drop.

Refrigerant Line Sizing Chart (English Units) (con't.)

14 SEER Single-Stage Heat Pumps												
Unit Size	Allowable Liquid Line Size	Allowable Vapor Line Size	Apply Long Line Guidelines if Linear Line Length Exceeds Those Shown Below (Feet) (-)P14-F	Outdoor Unit ABOVE or BELOW Indoor Unit Equivalent Length (Feet)								
				< 25	26-50	51-75	76-100	101-125	126-150	151-175	176-200	201-225
				Maximum Vertical Separation / Capacity Multiplier								
4 Ton	3/8"	3/4"	0	25 / 0.99	50 / 0.98	75 / 0.96	77 / 0.95	67 / 0.93	57 / 0.92	46 / 0.91	N/R	N/R
	1/2"	3/4"	0	25 / 0.99	50 / 0.98	75 / 0.96	100 / 0.95	100 / 0.93	100 / 0.92	100 / 0.91	N/R	N/R
	3/8"	7/8"	0	25 / 1.00	50 / 0.99	75 / 0.99	77 / 0.98	67 / 0.97	57 / 0.97	46 / 0.96	36 / 0.96	26 / 0.95
	1/2"	7/8"	0	25 / 1.00	50 / 0.99	75 / 0.99	100 / 0.98	100 / 0.97	100 / 0.97	100 / 0.96	100 / 0.96	99 / 0.95
5 Ton	3/8"	3/4"	0	25 / 0.99	50 / 0.97	75 / 0.94	61 / 0.92	46 / 0.90	N/R	N/R	N/R	N/R
	1/2"	3/4"	0	25 / 0.99	50 / 0.97	75 / 0.94	100 / 0.92	100 / 0.90	N/R	N/R	N/R	N/R
	3/8"	7/8"	0	25 / 1.00	50 / 0.99	75 / 0.98	61 / 0.97	46 / 0.96	32 / 0.95	18 / 0.94	N/R	N/R
	1/2"	7/8"	0	25 / 1.00	50 / 0.99	75 / 0.98	100 / 0.97	100 / 0.96	100 / 0.95	97 / 0.94	95 / 0.94	89 / 0.92
	3/8"	1-1/8"	0	25 / 1.01	50 / 1.01	75 / 1.00	61 / 1.00	46 / 0.99	32 / 0.99	18 / 0.99	N/R	N/R
	1/2"	1-1/8"	0	25 / 1.01	50 / 1.01	75 / 1.00	100 / 1.00	100 / 0.99	100 / 0.99	97 / 0.99	95 / 0.99	92 / 0.99

Notes:

- 1) Do not exceed 200 ft linear line length.
- 2) Do not exceed 100 ft vertical separation between indoor and outdoor units.
- 3) *3/4" vapor line should only be used for 1.5 ton systems if outdoor unit is below or at same level as indoor unit to assure proper oil return.
- 4) Always use the smallest liquid line allowable to minimize refrigerant charge.
- 5) Applications shaded in light gray indicate capacity multipliers between 0.90 and 0.96 which are not recommended, but are allowed.
- 6) Applications shaded in dark gray are not recommended due to excessive liquid or suction line pressure drop.

Refrigerant Line Sizing Chart (Metric Units)

Unit Size	Allowable Liquid Line Size mm [in.]	Allowable Vapor Line Size mm [in.]	Apply Long Line Guidelines If Linear Line Length Exceeds Those Shown Below (Meters)	14 SEER Single-Stage Heat Pumps										
				Outdoor Unit ABOVE or BELOW Indoor Unit Equivalent Length (Meters)										
				< 8	8-15	16-23	24-30	31-38	39-46	47-53	54-61	62-69	70-76	
5.3 kW [1.5 Ton] **SEE NOTE 3	6.35 [1/4]	15.88 [5/8]	30	8/1.00	15/0.99	19/0.98	13/0.98	7/0.97	2/0.97	N/R	N/R	N/R	N/R	N/R
	7.94 [5/16]	15.88 [5/8]	24	8/1.00	15/0.99	23/0.98	30/0.98	28/0.97	27/0.97	25/0.96	24/0.96	22/0.95	21/0.94	
	9.53 [3/8]	15.88 [5/8]	17	8/1.00	15/0.99	23/0.98	30/0.98	30/0.97	30/0.97	30/0.96	30/0.96	30/0.95	30/0.94	
	6.35 [1/4]	19.05 [3/4]*	30	8/1.00	15/1.00	19/0.99	13/0.99	7/0.99	2/0.99	N/R	N/R	N/R	N/R	
	7.94 [5/16]	19.05 [3/4]*	24	8/1.00	15/1.00	23/0.99	30/0.99	28/0.99	27/0.99	25/0.99	24/0.98	22/0.98	21/0.98	
	9.53 [3/8]	19.05 [3/4]*	17	8/1.00	15/1.00	23/0.99	30/0.99	30/0.99	30/0.99	30/0.99	30/0.99	30/0.98	30/0.98	
	6.35 [1/4]	15.88 [5/8]	N/A	8/0.99	15/0.98	6/0.97	N/R	N/R	N/R	N/R	N/R	N/R	N/R	
	7.94 [5/16]	15.88 [5/8]	37	8/0.99	15/0.98	23/0.97	27/0.96	23/0.95	21/0.94	19/0.93	16/0.92	14/0.91	11/0.90	
	9.53 [3/8]	15.88 [5/8]	25	8/0.99	15/0.98	23/0.97	30/0.96	30/0.95	30/0.94	30/0.93	29/0.92	28/0.91	27/0.90	
7.0 kW [2 Ton]	6.35 [1/4]	19.05 [3/4]	N/A	8/1.00	15/1.00	6/0.99	N/R	N/R	N/R	N/R	N/R	N/R	N/R	
	7.94 [5/16]	19.05 [3/4]	37	8/1.00	15/1.00	23/0.99	27/0.99	23/0.98	21/0.98	19/0.98	16/0.97	14/0.97	11/0.96	
	9.53 [3/8]	19.05 [3/4]	25	8/1.00	15/1.00	23/0.99	30/0.99	30/0.99	30/0.98	30/0.98	29/0.97	28/0.97	27/0.96	
	7.94 [5/16]	15.88 [5/8]	31	8/0.99	15/0.98	23/0.96	21/0.94	18/0.93	15/0.91	11/0.90	N/R	N/R	N/R	
	9.53 [3/8]	15.88 [5/8]	21	8/0.99	15/0.98	23/0.96	30/0.94	30/0.93	29/0.91	27/0.90	N/R	N/R	N/R	
	7.94 [5/16]	19.05 [3/4]	31	8/1.00	15/0.99	23/0.99	21/0.98	18/0.98	15/0.97	11/0.96	8/0.96	4/0.95	N/R	
	9.53 [3/8]	19.05 [3/4]	21	8/1.00	15/0.99	23/0.99	30/0.98	30/0.98	29/0.97	27/0.96	26/0.96	25/0.95	24/0.95	
	7.94 [5/16]	15.88 [5/8]	30	8/0.99	15/0.97	20/0.94	15/0.92	10/0.90	N/R	N/R	N/R	N/R	N/R	
	9.53 [3/8]	15.88 [5/8]	20	8/0.99	15/0.97	23/0.94	29/0.92	27/0.90	N/R	N/R	N/R	N/R	N/R	
10.6 kW [3 Ton]	7.94 [5/16]	19.05 [3/4]	30	8/1.00	15/0.99	20/0.98	15/0.98	10/0.97	5/0.96	N/R	N/R	N/R	N/R	
	9.53 [3/8]	19.05 [3/4]	20	8/1.00	15/0.99	23/0.98	29/0.98	27/0.97	26/0.96	24/0.95	22/0.94	20/0.93	19/0.93	
	12.7 [1/2]	19.05 [3/4]	10	8/1.00	15/0.99	23/0.98	30/0.98	30/0.97	30/0.96	30/0.95	30/0.94	30/0.93	30/0.93	
	7.94 [5/16]	22.23 [7/8]	30	8/1.00	15/1.00	20/1.00	15/0.99	10/0.99	5/0.99	N/R	N/R	N/R	N/R	
	9.53 [3/8]	22.23 [7/8]	20	8/1.00	15/1.00	23/1.00	29/0.99	27/0.99	26/0.99	24/0.98	22/0.98	20/0.98	19/0.97	
	12.7 [1/2]	22.23 [7/8]	10	8/1.00	15/1.00	23/1.00	30/0.99	30/0.99	30/0.99	30/0.98	30/0.98	30/0.98	30/0.97	
	9.53 [3/8]	19.05 [3/4]	28	8/0.99	15/0.98	23/0.97	27/0.96	24/0.95	22/0.94	20/0.92	17/0.91	15/0.90	N/R	
	12.7 [1/2]	19.05 [3/4]	14	8/0.99	15/0.98	23/0.97	30/0.96	30/0.95	30/0.94	30/0.92	30/0.91	30/0.90	N/R	
	9.53 [3/8]	22.23 [7/8]	28	8/1.00	15/1.00	23/0.99	27/0.99	24/0.99	22/0.98	20/0.97	17/0.97	15/0.96	13/0.96	
12.7 [1/2]	22.23 [7/8]	14	8/1.00	15/1.00	23/0.99	30/0.99	30/0.99	30/0.98	30/0.97	30/0.97	30/0.96	30/0.96		

Notes:
 1) Do not exceed 61 meters linear line length.
 2) Do not exceed 30 meters vertical separation between indoor and outdoor units.
 3) *19.05mm [3/4 in.] vapor line should only be used for 1.5 ton systems if outdoor unit is below or at same level as indoor unit to assure proper oil return.
 4) Always use the smallest liquid line allowable to minimize refrigerant charge.
 5) Applications shaded in light gray indicate capacity multipliers between 0.90 and 0.96 which are not recommended, but are allowed.
 6) Applications shaded in dark gray are not recommended due to excessive liquid or suction line pressure drop.

Refrigerant Line Sizing Chart (Metric Units) (con't.)

14 SEER Single-Stage Heat Pumps												
Unit Size	Allowable Liquid Line Size mm [in.]	Allowable Vapor Line Size mm [in.]	Apply Long Line Guidelines if Linear Line Length Exceeds Those Shown Below (Meters) (-)P14-F	Outdoor Unit ABOVE or BELOW Indoor Unit Equivalent Length (Meters)								
				< 8	8-15	16-23	24-30	31-38	39-46	47-53	54-61	62-69
				Maximum Vertical Separation / Capacity Multiplier								
14.1 kW [4 Ton]	9.53 [3/8]	19.05 [3/4]	0	8 / 0.99	15 / 0.98	23 / 0.96	24 / 0.95	20 / 0.93	17 / 0.92	14 / 0.91	N/R	N/R
	12.7 [1/2]	19.05 [3/4]	0	8 / 0.99	15 / 0.98	23 / 0.96	30 / 0.95	30 / 0.93	30 / 0.92	30 / 0.91	N/R	N/R
	9.53 [3/8]	22.23 [7/8]	0	8 / 1.00	15 / 0.99	23 / 0.99	24 / 0.98	20 / 0.97	17 / 0.97	14 / 0.96	11 / 0.96	8 / 0.95
	12.7 [1/2]	22.23 [7/8]	0	8 / 1.00	15 / 0.99	23 / 0.99	30 / 0.98	30 / 0.97	30 / 0.97	30 / 0.96	30 / 0.95	30 / 0.95
17.6 kW [5 Ton]	9.53 [3/8]	19.05 [3/4]	0	8 / 0.99	15 / 0.97	23 / 0.94	19 / 0.92	14 / 0.90	N/R	N/R	N/R	N/R
	12.7 [1/2]	19.05 [3/4]	0	8 / 0.99	15 / 0.97	23 / 0.94	30 / 0.92	30 / 0.90	N/R	N/R	N/R	N/R
	9.53 [3/8]	22.23 [7/8]	0	8 / 1.00	15 / 0.99	23 / 0.98	19 / 0.97	14 / 0.96	10 / 0.95	5 / 0.94	N/R	N/R
	12.7 [1/2]	22.23 [7/8]	0	8 / 1.00	15 / 0.99	23 / 0.98	30 / 0.97	30 / 0.96	30 / 0.95	30 / 0.94	29 / 0.94	28 / 0.93
	9.53 [3/8]	28.58 [1-1/8]	0	8 / 1.01	15 / 1.01	23 / 1.00	19 / 1.00	14 / 0.99	10 / 0.99	5 / 0.99	N/R	N/R
	12.7 [1/2]	28.58 [1-1/8]	0	8 / 1.01	15 / 1.01	23 / 1.00	30 / 1.00	30 / 0.99	30 / 0.99	30 / 0.99	29 / 0.99	28 / 0.99

Notes:

- 1) Do not exceed 61 meters linear line length.
- 2) Do not exceed 30 meters vertical separation between indoor and outdoor units.
- 3) *19.05mm [3/4 in.] vapor line should only be used for 1.5 ton systems if outdoor unit is below or at same level as indoor unit to assure proper oil return.
- 4) Always use the smallest liquid line allowable to minimize refrigerant charge.
- 5) Applications shaded in light gray indicate capacity multipliers between 0.90 and 0.96 which are not recommended, but are allowed.
- 6) Applications shaded in dark gray are not recommended due to excessive liquid or suction line pressure drop.

Performance Data @ AHRI Standard Conditions – Heat Pump

Designated Tested Combination (DTC)												
Outdoor Unit	Air Handler	Total Capacity BTU/H [kW]	Net Sensible BTU/H [kW]	Net Latent BTU/H [kW]	SEER	EER	Indoor CFM [L/s]	47 Degree Heating Capacity BTU/H [kW]	47 Degree COP	17 Degree Heating Capacity BTU/H [kW]	17 Degree COP	Region IV HSPF
F02414RSJ**F	FH2417TTS*SN	24000 [7.0]	17900 [5.2]	6100 [1.8]	14.50	12.00	800 [377.6]	22000 [6.4]	3.70	13500 [4.0]	2.50	8.50
F03014RSJ**F	FH3617TTS*SN	29400 [8.6]	22500 [6.6]	6900 [2.0]	14.50	12.00	1025 [483.7]	27000 [7.9]	3.70	16600 [4.9]	2.40	8.50
F03614RSJ**F	FH3617TTS*SN	35600 [10.4]	26400 [7.7]	9200 [2.7]	14.50	12.00	1175 [554.5]	33800 [9.9]	3.66	22400 [6.6]	2.66	8.50
F04214RSC**F	FH4821TTS*SN	42500 [12.5]	30600 [9.0]	11900 [3.5]	14.50	12.00	1350 [637.1]	40000 [11.7]	3.76	25600 [7.5]	2.60	8.50
F04214RSJ**F	FH4821TTS*SN	42500 [12.5]	30600 [9.0]	11900 [3.5]	14.50	12.00	1350 [637.1]	40000 [11.7]	3.76	25600 [7.5]	2.60	8.50
F04814RSC**F	FH4821TTS*SN	47000 [13.8]	34100 [10.0]	12900 [3.8]	14.50	12.00	1500 [707.9]	44500 [13.0]	3.66	29000 [8.5]	2.60	8.50
F04814RSJ**F	FH4821TTS*SN	47000 [13.8]	34100 [10.0]	12900 [3.8]	14.50	12.00	1500 [707.9]	44500 [13.0]	3.66	29000 [8.5]	2.60	8.50
F06014RSC**F	FH6024TTS*SN	58000 [17.0]	42400 [12.4]	15600 [4.6]	14.50	12.00	1775 [837.7]	56000 [16.4]	3.76	35600 [10.4]	2.66	8.50
F06014RSJ**F	FH6024TTS*SN	58000 [17.0]	42400 [12.4]	15600 [4.6]	14.50	12.00	1775 [837.7]	56000 [16.4]	3.76	35600 [10.4]	2.66	8.50

Note: Additional ratings and system match ups and downloadable ratings certificates can be accessed from the AHRI website: www.ahridirectory.org

[J] Designates Metric Conversions

GUIDE SPECIFICATIONS

General

System Description

Outdoor-mounted, air-cooled, split-system heat pump unit suitable for ground or rooftop installation. Unit consists of a hermetic compressor, composite basepan, an air-cooled coil, propeller-type condenser fan, suction and liquid line service valve, and a control box. Unit will discharge supply air upward as shown on contract drawings. Unit will be used in a refrigeration circuit to match up to a coil unit.

Quality Assurance

- Unit will be rated in accordance with the latest edition of AHRI Standard 210.
- Unit will be certified for capacity and efficiency, and listed in the latest AHRI directory.
- Unit construction will comply with latest edition of ANSI/ASHRAE and with NEC.
- Unit will be constructed in accordance with UL standards and will carry the UL label of approval. Unit will have c-UL-us approval.
- Unit cabinet will be capable of withstanding ASTM B117 1000-hr salt spray test.
- Air-cooled condenser coils will be leak tested at 150 psig and pressure tested at 550 psig.
- Unit constructed in ISO9001 approved facility.

Delivery, Storage, and Handling

- Unit will be shipped as single package only and is stored and handled per unit manufacturer's recommendations.

Warranty (for inclusion by specifying engineer) – U.S. and Canada only.

Products

Equipment

Factory assembled, single piece, air-cooled heat pump unit. Contained within the unit enclosure is all factory wiring, piping, controls, compressor, refrigerant charge R-410A, and special features required prior to field start-up.

Unit Cabinet

- Unit cabinet will be constructed of galvanized steel, bonderized, and coated with a powder coat paint.
- All units constructed with louver coil protection and corner post. Louver can be removed by removing one fastener per louver panel.

AIR-COOLED, SPLIT-SYSTEM HEAT PUMP

FO*14R*F

1-1/2 TO 5 NOMINAL TONS

Fans

- Condenser fan will be direct-drive propeller type, discharging air upward.
- Condenser fan motors will be totally enclosed, 1-phase type with class B insulation and permanently lubricated bearings. Shafts will be corrosion resistant.
- Fan blades will be statically and dynamically balanced.
- Condenser fan openings will be equipped with coated steel wire safety guards.

Compressor

- Compressor will be hermetically sealed.
- Compressor will be mounted on rubber vibration isolators.

Condenser Coil

- Condenser coil will be air cooled.
- Coil will be constructed of aluminum fins mechanically bonded to copper tubes.

Refrigeration Components

- Refrigeration circuit components will include liquid-line shutoff valve with sweat connections, vapor-line shutoff valve with sweat connections, system charge of R-410A refrigerant, and compressor oil.
- Unit will be equipped with filter drier for R-410A refrigerant for field installation.

Operating Characteristics

- The capacity of the unit will meet or exceed _____ Btuh at a suction temperature of _____ °F/°C. The power consumption at full load will not exceed _____ kW.
- Combination of the unit and the evaporator or fan coil unit will have a total net cooling capacity of _____ Btuh or greater at conditions of _____ CFM entering air temperature at the evaporator at _____ °F/°C wet bulb and _____ °F/°C dry bulb, and air entering the unit at _____ °F/°C.
- The system will have a SEER of _____ Btuh/watt or greater at DOE conditions.

Electrical Requirements

- Nominal unit electrical characteristics will be _____ v, single phase, 60 hz. The unit will be capable of satisfactory operation within voltage limits of _____ v to _____ v.
- Nominal unit electrical characteristics will be _____ v, three phase, 60 hz. The unit will be capable of satisfactory operation within voltage limits of _____ v to _____ v.
- Unit electrical power will be single point connection.
- Control circuit will be 24v.

Special Features

- Refer to section of this literature identifying accessories and descriptions for specific features and available enhancements.

GENERAL TERMS OF LIMITED WARRANTY*

Fujitsu General America, Inc. will furnish a replacement for any part of this product which fails in normal use and service within the applicable period stated, in accordance with the terms of the limited warranty.

Conditional Parts
(Registration Required)Ten (10) Years

***For complete details of the Limited and Conditional Warranties, including applicable terms and conditions, contact your local contractor or the Manufacturer for a copy of the product warranty certificate.**

Before proceeding with installation, refer to installation instructions packaged with each model, as well as complying with all Federal, State, Provincial, and Local codes, regulations, and practices.

"In keeping with its policy of continuous progress and product improvement, the right is reserved to make changes without notice."