

Product Specifications

NOTE: Read the entire instruction manual before starting the installation.

- 1-1/2 thru 5 tons
- Available for environmentally balanced R-410A systems
- TXV metering device factory installed
- ECM motor
- Sweat connections
- Primary and secondary drain fittings with brass inserts
- 3 amp automotive type fuse in wire harness
- Multiple electrical entry locations
- Time delay relay (TDR) programmed in motor
- Field installed heater packages from 5 kW - 30 kW available separately
- HUD approved for manufactured housing
- 208/230-1-60 supply voltage
- Assembled at the factory compliant with low leak requirements of less than 2% cabinet leakage rate at 0.5 inches W.C. and 1.4% cabinet leakage rate at 0.5 inches W.C. when tested in accordance with ASHRAE 193 standard.
- 1 inch thick insulation with R value of 4.2
- Multiposition installation - upflow or horizontal left standard, horizontal right with minor modification (field convertible to downflow with available accessory kit)
- No Heat (Plug) Kit factory installed
- Filter (washable) factory supplied



Use of the AHRI Certified TM Mark indicates a manufacturer's participation in the program. For verification of certification for individual products, go to www.ahridirectory.org.



A200369

WARRANTY*

- 5 year No Hassle replacement limited warranty
- 5 year parts limited warranty
- With timely registration, an additional 5 year parts limited warranty
 - * For owner occupied, residential applications only. See warranty certificate for complete details and restrictions, including warranty coverage for other applications.

Model Number	Tons	Nom. CFM (L/s)	Dimensions H x W x D in. (mm)	Filter Size in. (mm)	Ship Wt lbs. (kg)
FXM4X1800AL	1½	600 (283)	49-5/8 x 17-5/8 x 22-1/16 (1261 x 448 x 560)	16-3/8 x 21-1/2 (416 x 546)	122 (55)
FXM4X2400AL	2	800 (378)	49-5/8 x 17-5/8 x 22-1/16 (1261 x 448 x 560)	16-3/8 x 21-1/2 (416 x 546)	122 (55)
FXM4X3000AL	2½	1000 (472)	53-7/16 x 21-1/8 x 22-1/16 (1357 x 537 x 560)	19-7/8 x 21-1/2 (505 x 546)	146 (66)
FXM4X3600AL	3	1200 (566)	49-5/8 x 21-1/8 x 22-1/16 (1261 x 537 x 560)	19-7/8 x 21-1/2 (505 x 546)	157 (71)
FXM4X4200AL	3½	1400 (661)	49-5/8 x 21-1/8 x 22-1/16 (1261 x 537 x 560)	19-7/8 x 21-1/2 (505 x 546)	157 (71)
FXM4X4800AL	4	1600 (755)	53-1/16 x 24-11/16 x 22-1/16 (1357 x 627 x 576)	23-5/16 x 21-1/2 (592 x 546)	185 (84)
FXM4X6000AL	5	2000 (944)	59-3/16 x 24-11/16 x 22-1/16 (1503 x 627 x 576)	23-5/16 x 21-1/2 (592 x 546)	201 (91)

FAN COIL MODEL NUMBER IDENTIFICATION GUIDE								
	F	X	M	4	X	1800	A	L
F = Fan Coil								
X = ECM		MOTOR TYPE						
M = Multiposition		INSTALLATION TYPE						
4 = Environmentally Sound R-410A		REFRIGERANT						
X = TXV		METERING DEVICE						
1800 = 18,000 BTUH = 1-1/2 tons								
2400 = 24,000 BTUH = 2 tons								
3000 = 30,000 BTUH = 2-1/2 tons								
3500 & 3600 = 36,000 BTUH = 3 tons								
4200 = 42,000 BTUH = 3-1/2 tons								
4800 = 48,000 BTUH = 4 tons								
6000 = 60,000 BTUH = 5 tons								
						NOMINAL CAPACITY		
AL = Aluminum Tube, Aluminum Fin Evaporator Coil							SALES CODE / FEATURES	

ACCESSORIES PART NUMBER IDENTIFICATION GUIDE					
	EB	AC	01	NCB	A
EB = Evaporator Blower					
AC = Accessory					
01 = Product Identifier Number					
NCB = Non-Combustible Base Kit					
DFK = Down Flow Kit					
PLG = Power Plug (no heat kit)					
SPK = Single Point Wiring Kit					
FKS = Filter Kit Small					
FKM = Filter Kit Medium					
FKL = Filter Kit Large					
FKX = Filter Kit Extra Large					
CTK = Condensate Trap Kit (PVC pipe)					
Sales Code					

ELECTRIC HEATER MODEL NUMBER IDENTIFICATION GUIDE						
	EHK	05	A	K	N	1
EHK = Electric Heater Kit						
05 = 5 kW						
07 = 7 kW						
09 = 9 kW						
10 = 10 kW						
15 = 15 kW						
18 = 18 kW						
20 = 20 kW						
25 = 25 kW						
30 = 30 kW						
			NOMINAL HEAT VALUE			
Sales Code						
K = 208 / 230, single-phase						
H = 208 / 230, 3-phase						
KC = 208 / 230, supplied as single phase, field convertible to 3-phase						
HC = 208 / 230 supplied as 3-phase, field convertible to single phase						
				VOLTAGE (60 Hz)		
Product Identifier						
Engineering Code						

Manufacturer reserves the right to change, at any time, specifications and designs without notice and without obligations.

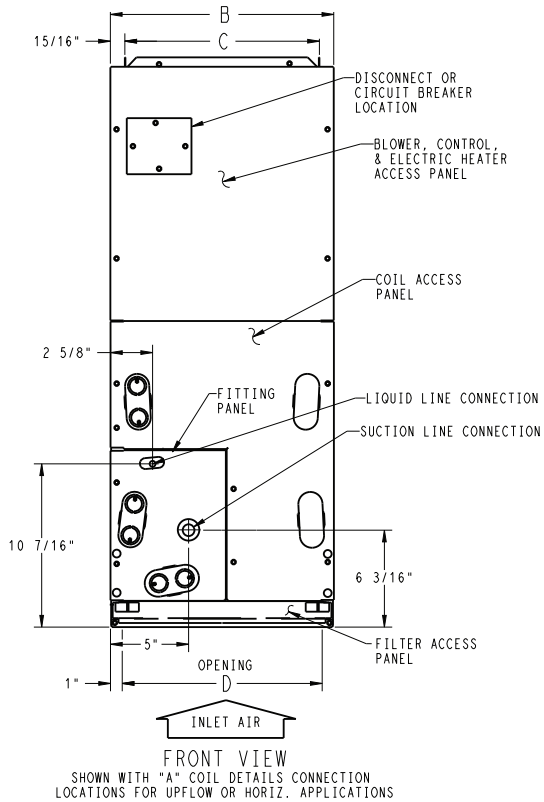
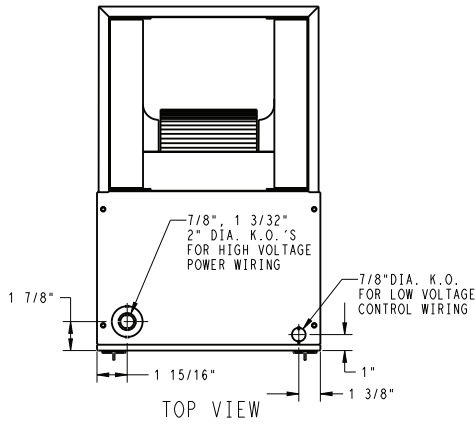

UNIT	SERIES	ELECTRICAL CHARACTERISTICS				A	B	C	D	E	F	G	H	J	COIL CONFIGURATION	SHIPPING WT (LBS)
		X	*												SLOPE	
FXM4X18	2,03,04	X	*			49 5/8"	17 5/8"	15 3/4"	15 5/8"	15 3/8"	23 1/8"	23 5/8"	-	17"	X -	128
FXM4X24	3,4,05,06	X	*			49 5/8"	17 5/8"	15 3/4"	15 5/8"	15 3/8"	23 1/8"	23 5/8"	-	17"	X -	128
FXM4X30	3,4,05,06	X	*			53 7/16"	21 1/8"	19 1/4"	19 1/8"	19 3/16"	26 15/16"	27 1/2"	-	19"	X -	152
FXM4X36	5,6,7,08,09,10,11	X	*			49 5/8"	21 1/8"	19 1/4"	19 1/8"	15 11/16"	23 7/16"	23 1/8"	-	-	- X	163
FXM4X42	5,6,7,08,09,10,11	X	*			49 5/8"	21 1/8"	19 1/4"	19 1/8"	15 11/16"	23 7/16"	23 1/8"	-	-	- X	163
FXM4X48	5,6,7,08,09,10,11	X	*			53 7/16"	24 11/16"	22 3/4"	22 11/16"	19 1/2"	27 1/4"	26 15/16"	28 5/16"	-	- X	191
FXM4X60	3,4,5,06,07,08,09	X	*			59 3/16"	24 11/16"	22 3/4"	22 11/16"	25 1/4"	32 15/16"	32 5/8"	34 1/16"	-	- X	207

208/230-1-60
208/230-3-60

X=YES
O=NO
*=YES, DUE TO AVAILABLE FIELD INSTALLED HEATERS.

- NOTE:
- SERIES DESIGNATION IS THE 12TH POSITION OF UNIT PRODUCT NUMBER
 - ALL DIMENSIONS ARE IN "INCHES" UNLESS NOTED.

UNIT CONNECTION SIZES

SUCTION: 18 & 24 - 5/8" I.D. SWEAT
30 & 36 - 3/4" I.D. SWEAT
42 THRU 60 - 7/8" I.D. SWEAT
LIQUID: 3/8" I.D. SWEAT
CONDENSATE: 3/4" FPT

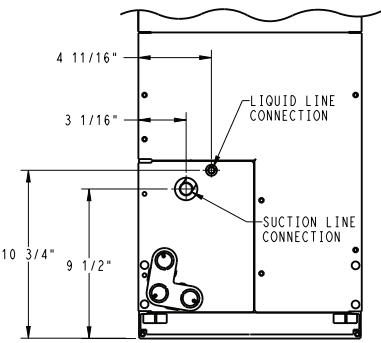

SLOPE COIL DETAILS
CONNECTION LOCATIONS SHOWN FOR UPFLOW OR HORIZ. LEFT APPLICATIONS

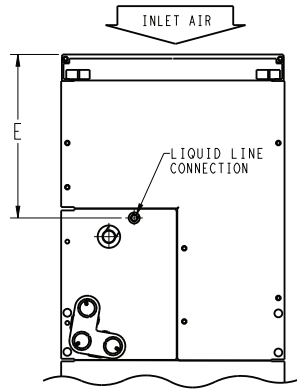

ACCESS PANEL CONFIG. FOR SLOPE COILS DOWNFLOW OR HORIZ. RIGHT APPLICATIONS AND "A" COILS DOWNFLOW APPLICATIONS

NOTE: ALLOW 21" FROM FRONT FOR SERVICE

ALTERNATE 7/8" DIA. K.O. FOR LOW VOLTAGE CONTROL WIRING

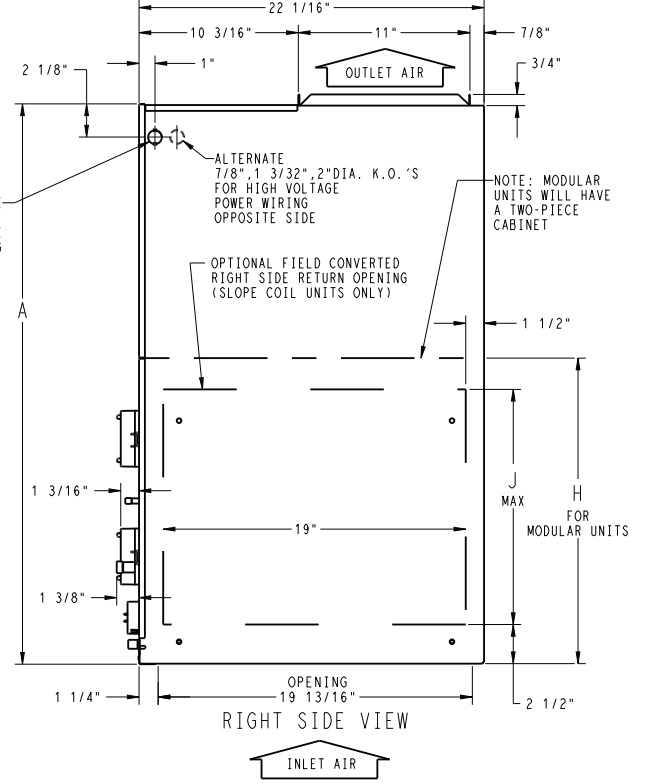

RIGHT SIDE VIEW

Fig. 1 – FXM4X – English (sheet 1)

SLOPE COIL

NOTES:

1. CONDENSATE PAN DRAIN CAPS NOT SHOWN FOR CLARITY.
2. ALL DIMENSIONS ARE IN "INCHES" UNLESS NOTED.

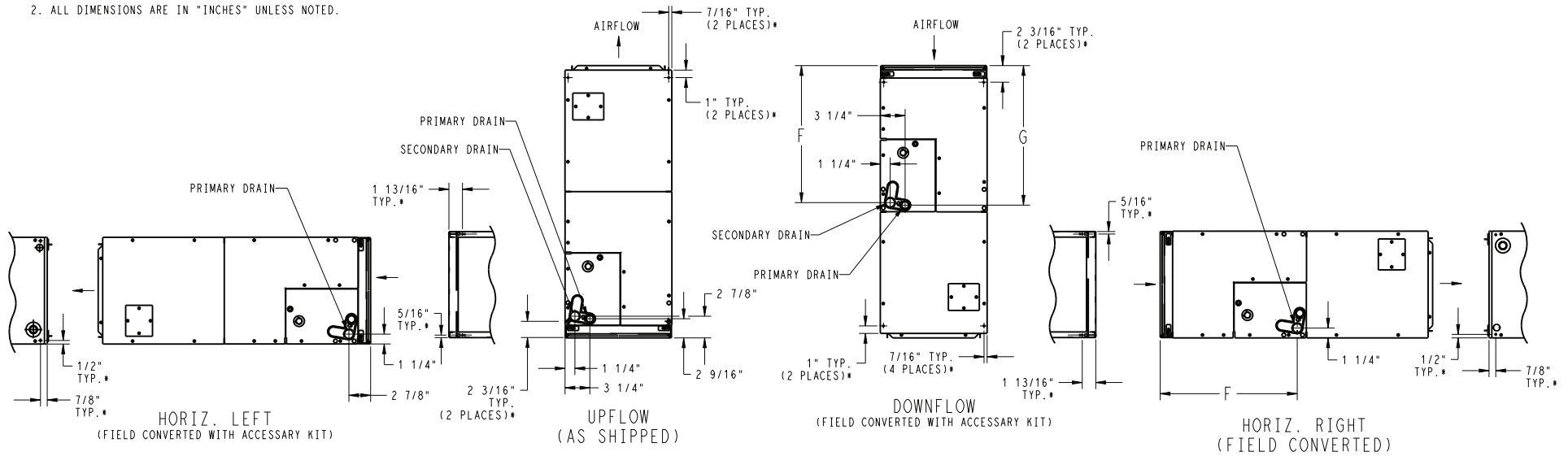

* HORIZONTAL MOUNT LOCATIONS - DIMPLES PROVIDED IN TOP PANEL, AND BACK OF CABINET. IN CABINET BOTTOM, HOLES PROVIDED .136" DIA. HORIZONTAL HANGING HARDWARE TO BE FIELD SUPPLIED.

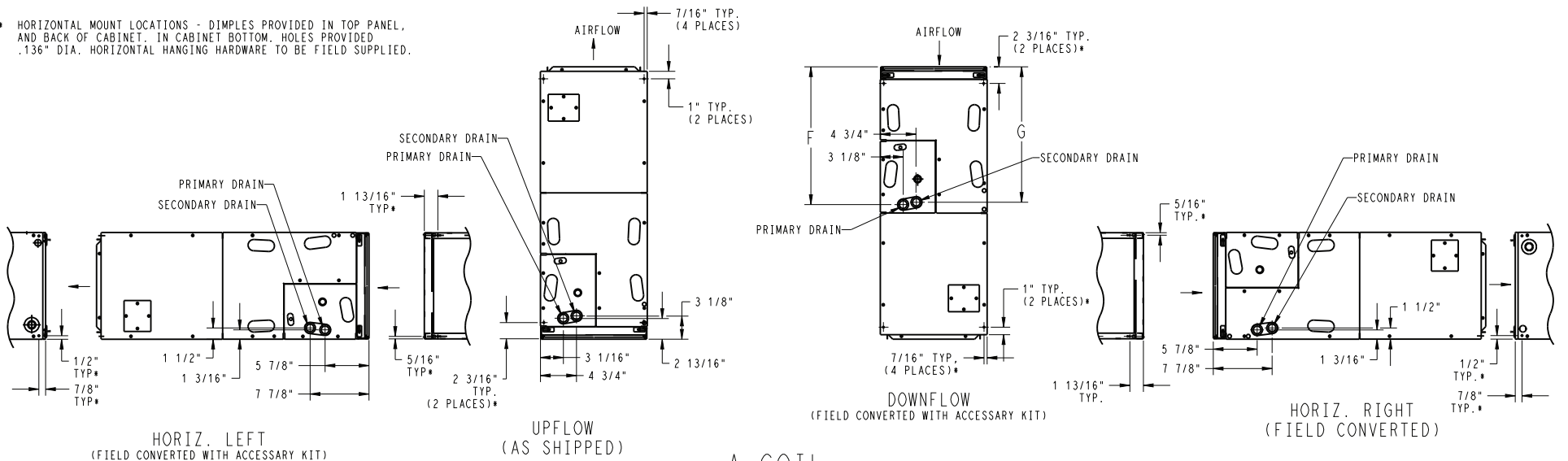

A-COIL

Fig. 2 – FXM4X – English (sheet 2)

Manufacturer reserves the right to change, at any time, specifications and designs without notice and without obligations.

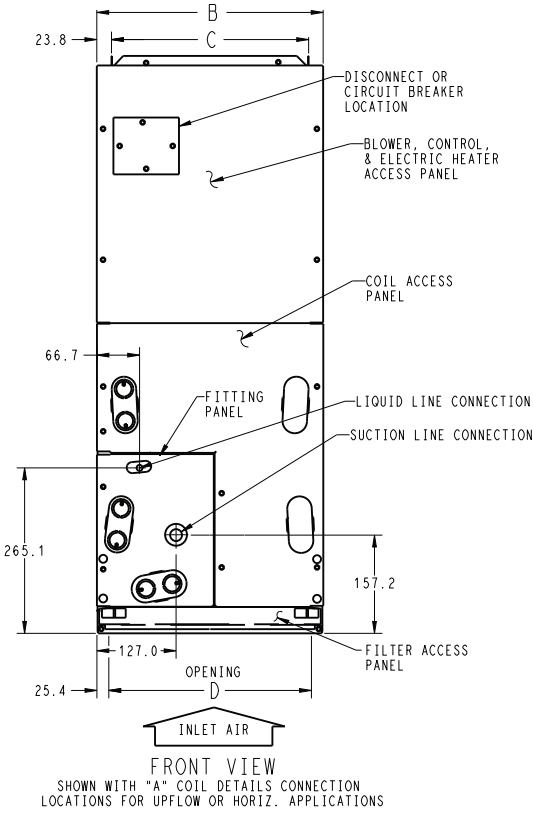
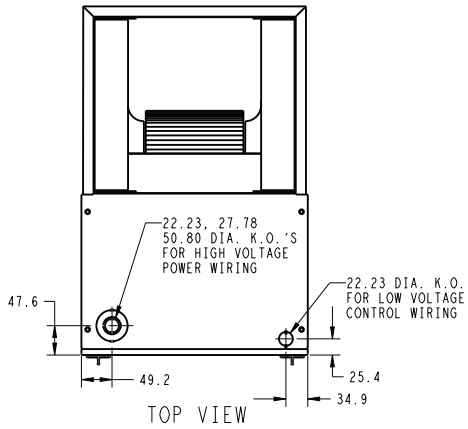

UNIT	SERIES	ELECTRICAL CHARACTERISTICS			A	B	C	D	E	F	G	H	J	COIL CONFIGURATION		SHIPPING WT (Kgs)
														SLOPE	"A"	
FXM4X18	2,03,04	X	*		1260.5	447.7	400.0	396.9	390.5	587.4	600.1	-	431.8	X	-	58.1
FXM4X24	3,4,05,06	X	*		1260.5	447.7	400.0	396.9	390.5	587.4	600.1	-	431.8	X	-	58.1
FXM4X30	3,4,05,06	X	*		1357.3	536.6	489.0	485.8	487.4	684.2	698.5	-	482.6	X	-	69.0
FXM4X36	5,6,7,08,09,10,11	X	*		1260.5	536.6	489.0	485.8	398.5	595.3	587.4	-	-	-	X	74.0
FXM4X42	5,6,7,08,09,10,11	X	*		1260.5	536.6	489.0	485.8	398.5	595.3	587.4	-	-	-	X	74.0
FXM4X48	5,6,7,08,09,10,11	X	*		1357.3	627.1	577.8	576.3	495.3	692.2	684.2	719.2	-	-	X	86.7
FXM4X60	3,4,5,06,07,08,09	X	*		1503.4	627.1	577.8	576.3	641.4	836.6	828.7	865.2	-	-	X	94.0

208/230-1-60
208/230-3-60

X=YES
O=NO
*=YES, DUE TO AVAILABLE FIELD INSTALLED HEATERS.

- NOTE:
- SERIES DESIGNATION IS THE 12TH POSITION OF UNIT PRODUCT NUMBER
 - ALL DIMENSIONS ARE IN "MM" UNLESS NOTED.

UNIT CONNECTION SIZES

SUCTION: 18 & 24 - 15.88 I.D. SWEAT
30 & 36 - 19.05 I.D. SWEAT
42 THRU 60 - 22.23 I.D. SWEAT
LIQUID: 9.53 I.D. SWEAT
CONDENSATE: 19.0 FPT

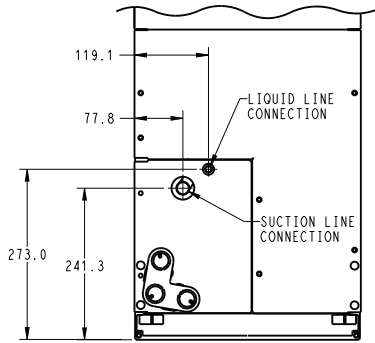

SLOPE COIL DETAILS
CONNECTION LOCATIONS SHOWN FOR UPFLOW OR HORIZ. LEFT APPLICATIONS

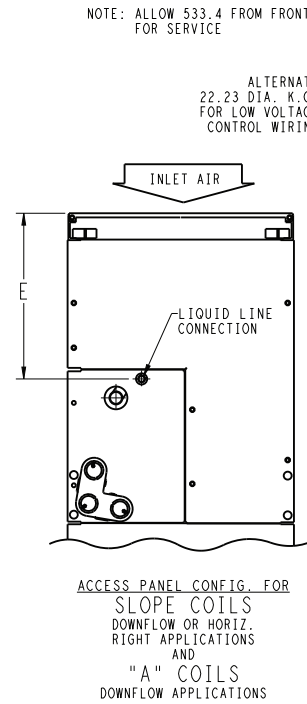

ACCESS PANEL CONFIG. FOR SLOPE COILS DOWNFLOW OR HORIZ. RIGHT APPLICATIONS AND "A" COILS DOWNFLOW APPLICATIONS

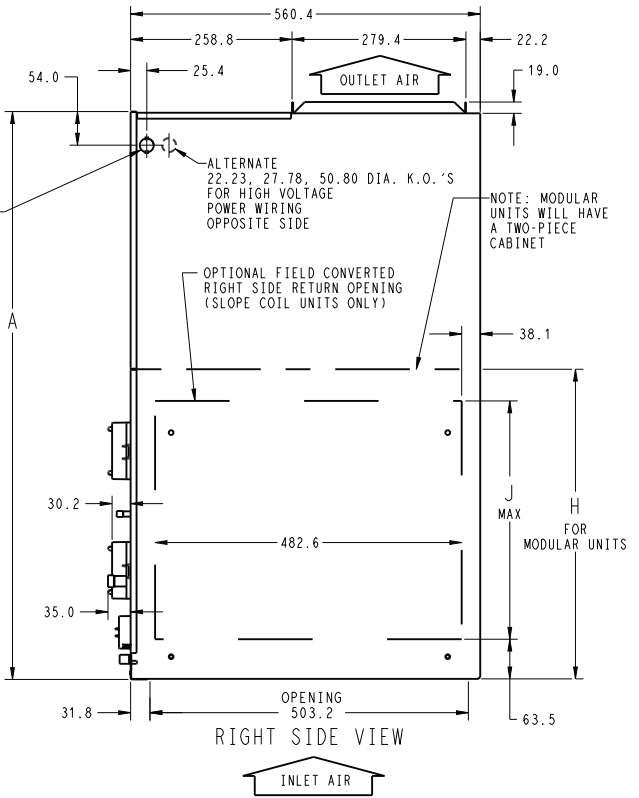

RIGHT SIDE VIEW

Fig. 3 – FXM4X – Metric (sheet 1)

NOTES:

1. CONDENSATE PAN DRAIN CAPS NOT SHOWN FOR CLARITY.
2. ALL DIMENSIONS ARE IN "MM" UNLESS NOTED.

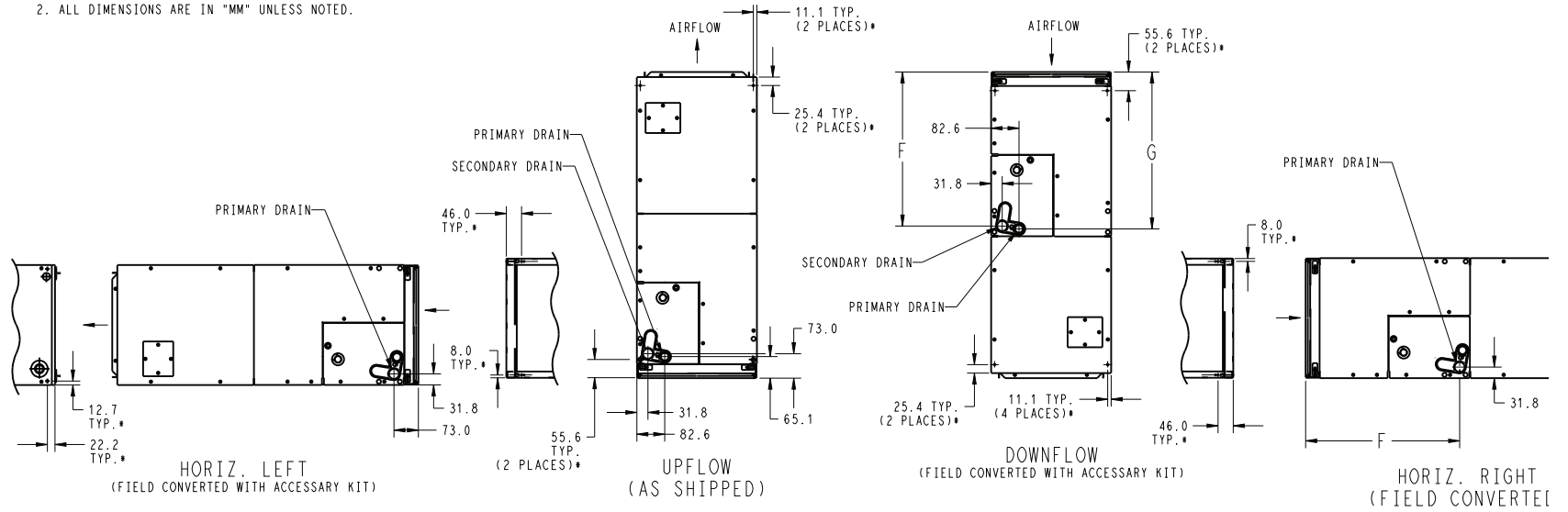

* HORIZONTAL MOUNT LOCATIONS - DIMPLES PROVIDED IN TOP PANEL, AND BACK OF CABINET. IN CABINET BOTTOM, HOLES PROVIDED 3.45 DIA. HORIZONTAL HANGING HARDWARE TO BE FIELD SUPPLIED.

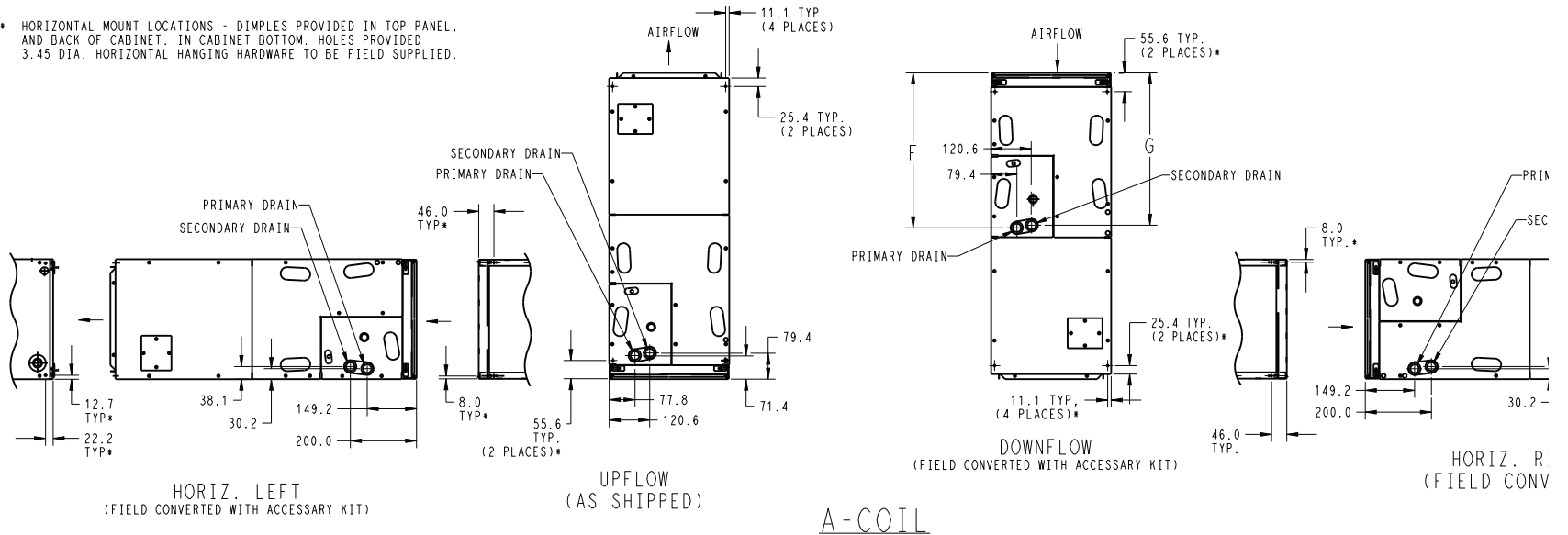

Fig. 4 – FXM4X – Metric (sheet 2)

DIMENSIONAL DATA (refer to drawings on previous pages)														
Model	Size (tons)	Dimensions Inches											Coil Type	Ship. Wt (lb)
		A	B	C	D	E	F	G	H	J	Suct	Liquid		
FXM4X1800	1-1/2	49-5/8	17-5/8	15-3/4	15-5/8	15-3/8	23-1/8	23-5/8	-	17	5/8	3/8	Slope	122
FXM4X2400	2	49-5/8	17-5/8	15-3/4	15-5/8	15-3/8	23-1/8	23-5/8	-	17	5/8	3/8	Slope	122
FXM4X3000	2-1/2	53-7/16	21-1/8	19-1/8	19-1/8	19-3/16	26-15/16	27-1/2	-	19	3/4	3/8	Slope	146
FXM4X3600	3	49-5/8	21-1/8	19-1/8	19-1/8	15-11/16	23-7/16	23-1/8	-	-	3/4	3/8	"A"	157
FXM4X4200	3-1/2	49-5/8	21-1/8	19-1/8	19-1/8	15-11/16	23-7/16	23-1/8	-	-	7/8	3/8	"A"	157
FXM4X4800	4	53-1/16	24-11/16	22-3/4	22-11/16	19-1/2	27-1/4	26-15/16	28-5/16	-	7/8	3/8	"A"	185
FXM4X6000	5	59-3/16	24-11/16	22-3/4	22-11/16	25-1/4	32-15/16	32-5/8	34-1/16	--	7/8	3/8	"A"	201

DIMENSIONAL DATA (refer to drawings on previous pages)														
Model	Size (tons)	Dimensions MM											Coil Type	Ship. Wt (lkg)
		A	B	C	D	E	F	G	H	J	Suct	Liquid		
FXM4X1800	1-1/2	1261	448	400	397	391	587	600	-	432	16	10	Slope	55
FXM4X2400	2	1261	448	400	397	391	587	600	-	432	16	10	Slope	55
FXM4X3000	2-1/2	1357	537	489	486	487	684	699	-	483	19	10	Slope	66
FXM4X3600	3	1261	537	489	486	399	595	587	-	-	19	10	"A"	71
FXM4X4200	3-1/2	1261	537	489	486	399	595	587	-	-	22	10	"A"	71
FXM4X4800	4	1357	627	578	576	495	692	684	719	-	22	10	"A"	84
FXM4X6000	5	1503	627	578	576	641	837	829	865	587	22	10	"A"	91

PHYSICAL DATA							
	Model Size						
	1800	2400	3000	3600	4200	4800	6000
Blower Data							
CFM nominal (L/s)	600 (283)	800 (378)	1000 (472)	1200 (566)	1400 (661)	1600 (755)	2000 (944)
Motor Type	ECM						
HP	1/3	1/3	1/2	1/2	1/2	3/4	3/4
Filter Data (factory supplied, washable)							
Filter Size in. (mm)	16-3/8 x 21-1/2 (416 x 546)		19-7/8 x 21-1/2 (505 x 546)			23-5/16 x 21-1/2 (592 x 546)	
Coil Data (all coils 14½ fins per inch, wavy lanced bare aluminum fin)							
Face Area ft2 (m2)	2.97 (0.28)	2.97 (0.28)	3.46 (0.32)	4.45 (0.41)		5.93 (0.55)	7.42 (0.69)
Refrigerant Line Connections (sweat)							
Liquid inch (mm)	3/8 (10)	3/8 (10)	3/8 (10)	3/8 (10)	3/8 (10)	3/8 (10)	3/8 (10)
Suction inch (mm)	5/8 (16)	5/8 (16)	3/4 (19)	3/4 (19)	7/8 (22)	7/8 (22)	7/8 (22)

ELECTRICAL DATA, FAN COIL ONLY WITHOUT ELECTRIC HEAT*			
Model	208/230V, single phase, 60 Hz		
	Motor Full Load Amps (FLA)	Minimum Circuit Ampacity (MCA)	Maximum Fuse/Ckt Bkr Amps (Max OverCurrent Protection - MOCP)
FXM4X1800	2.8	3.5	15
FXM4X2400	2.8	3.5	15
FXM4X3000	4.1	5.1	15
FXM4X3600	4.1	5.1	15
FXM4X4200	4.1	5.1	15
FXM4X4800	6.0	7.5	15
FXM4X6000	6.0	7.5	15

* SCCR (Short Circuit Current Rating) = 5kA rms, symmetrical, 230V

AIRFLOW PERFORMANCE - CFM at a given Speed and Static reading							
Model	Blower Speed	Measured Static Pressure, inlet to outlet (inches water column)					
		0.10	0.20	0.30	0.40	0.50	0.60
FXM4X1800	Tap 5	776	745	696	660	609	572
	Tap 4	683	644	589	548	494	461
	Tap 3	683	644	589	548	494	461
	Tap 2	631	563	500	443	409	361
	Tap 1	625	524	457	417	367	319
FXM4X2400	Tap 5	956	920	891	851	816	780
	Tap 4	825	795	757	722	674	634
	Tap 3	825	795	757	722	674	634
	Tap 2	726	695	635	598	543	509
	Tap 1	631	563	500	443	409	361
FXM4X3000	Tap 5	1189	1151	1104	1050	1003	959
	Tap 4	1041	998	944	886	837	772
	Tap 3	1041	998	944	886	837	772
	Tap 2	924	876	817	752	704	660
	Tap 1	779	693	628	571	526	476
FXM4X3600	Tap 5	1363	1332	1294	1253	1207	1157
	Tap 4	1237	1206	1160	1121	1070	1013
	Tap 3	1237	1206	1160	1121	1070	1013
	Tap 2	1095	1058	1007	951	888	824
	Tap 1	1014	885	773	673	609	549
FXM4X4200	Tap 5	1519	1490	1454	1419	1379	1332
	Tap 4	1437	1403	1366	1333	1294	1245
	Tap 3	1437	1403	1366	1333	1294	1245
	Tap 2	1257	1226	1191	1141	1090	1033
	Tap 1	1237	1206	1160	1121	1070	1013
FXM4X4800	Tap 5	1757	1725	1693	1653	1614	1576
	Tap 4	1664	1626	1593	1552	1517	1477
	Tap 3	1664	1626	1593	1552	1517	1477
	Tap 2	1459	1420	1379	1336	1298	1259
	Tap 1	1301	1241	1195	1150	1102	1039
FXM4X6000	Tap 5	2030	1995	1961	1927	1888	1842
	Tap 4	1811	1775	1740	1703	1664	1613
	Tap 3	1811	1775	1740	1703	1664	1613
	Tap 2	1665	1632	1593	1556	1507	1453
	Tap 1	1462	1418	1371	1327	1278	1228

NOTES:

1. Airflow based upon dry coil at 230v with factory approved filter and electric heater (2 element heater sizes 18 through 36, 3 element heater sizes 42 through 60).
2. Airflow at 208 volts is approximately the same as 230 volts because the X13 motor is a constant torque motor. The torque doesn't drop off at the speeds the motor operates.
3. To avoid potential for condensate blowing out of drain pan prior to making drain trap: Return static pressure must be less than 0.40 in. wc. Horizontal applications of 042 - 060 sizes must have supply static greater than 0.20 in. wc.
4. Airflow above 400 cfm/ton on 048 - 060 size could result in condensate blowing off coil or splashing out of drain pan.
5. Shading - Airflow outside 450 cfm/ton.

Static Pressure Drop Across Filter (inches of water column)									
Model Size	CFM								
	400	600	800	1000	1200	1400	1600	1800	2000
1800	.020	.044	.075	-	-	-	-	-	-
2400	-	.022	.048	.072	.100	-	-	-	-
3000	-	.022	.048	.072	.100	-	-	-	-
3600	-	-	-	.051	.070	.092	.120	.152	-
4200	-	-	-	.051	.070	.092	.120	.152	-
4800	-	-	-	.051	.070	.092	.120	.152	-
6000	-	-	-	-	-	-	.086	.105	.130

Static Pressure Correction from Dry to Wet Coil (inches of water column)																
Airflow performance chart was developed using fan coils with DRY coils. When taking a static reading across a WET coil, adjust the static pressure numbers by adding the values in this table (for a given CFM, wet coil will have greater static pressure drop than dry coil).																
Model Size	CFM															
	500	600	700	800	900	1000	1100	1200	1300	1400	1500	1600	1700	1800	1900	2000
1800	.034	.049	.063	-	-	-	-	-	-	-	-	-	-	-	-	-
2400	.016	.027	.038	.049	.059	-	-	-	-	-	-	-	-	-	-	-
3000	-	-	-	.049	.059	.070	.080	-	-	-	-	-	-	-	-	-
3600	-	-	-	-	-	.055	.064	.073	.081	-	-	-	-	-	-	-
4200	-	-	-	-	-	-	-	.049	.056	.063	.070	-	-	-	-	-
4800	-	-	-	-	-	-	-	-	-	.038	.043	.049	.054	.059	-	-
6000	-	-	-	-	-	-	-	-	-	-	-	.027	.031	.035	.039	.043

Static Pressure Correction for Electric Heaters (inches of water column)					
Airflow performance chart was developed using fan coils with 10 kW electric heater (2 elements) in the 1800 - 3600 model sizes, and 15 kW electric heaters (3 elements) in the 4200 - 6000 model sizes. When using a different number of heater elements, adjust the static pressure numbers by adding or subtracting the values in this table (for a given CFM, more electric heater elements create higher static pressure drop).					
Model Size	Heater kW				
	No Heater	3 or 5	8 or 10	9 or 15	20
	Number of Heat Elements				
	0	1	2	3	4
1800	+0.02	+0.01	0	-0.02	-0.04
2400	+0.02	+0.01	0	-0.02	-0.04
3000	+0.02	+0.01	0	-0.02	-0.04
3600	+0.02	+0.01	0	-0.02	-0.04
4200	+0.04	-	+0.02	0	-0.02
4800	+0.04	-	+0.02	0	-0.02
6000	+0.04	-	+0.02	0	-0.02

ESTIMATED SOUND POWER LEVEL (dBA)									
Model Size	Conditions		Octave Band Center Frequency*						
	CFM	Ext Static Pressure	63	125	250	500	1000	2000	4000
1800	600	0.25	64.7	60.7	56.7	53.7	51.7	49.7	45.7
2400	800	0.25	66.0	62.0	58.0	55.0	53.0	51.0	47.0
3000	1000	0.25	67.0	63.0	59.0	56.0	54.0	52.0	48.0
3600	1200	0.25	67.8	63.8	59.8	56.8	54.8	52.8	48.8
4200	1400	0.25	68.4	64.4	60.4	57.4	55.4	53.4	49.4
4800	1600	0.25	69.0	65.0	61.0	58.0	56.0	54.0	50.0
6000	2000	0.25	70.0	66.0	62.0	59.0	57.0	55.0	51.0

* Estimated sound power levels have been derived using the method described in the 1987 ASHRAE HVAC Systems & Applications Handbook, Ch 52, pg 52.7.

ELECTRIC HEATER Electrical Data

Heater Model	Heater kW		PHASE	INTERNAL CIRCUIT PROTECTION	HEATER AMPS 208/230V			BRANCH CIRCUIT															
								Min Ampacity ★ 208/230V				Min Wire Size (AWG) 208/230V ¹			Min Gnd Wire Size 208/230V			Max Fuse/Ckt Brk Amps 208/230V			Max Wire Length 208/230V (Ft) ††		
	230V	208V			Single Circuit	Dual Circuit		Single Circuit	Dual Circuit		Single Circuit	Dual Circuit			Single Circuit	Dual Circuit		Single Circuit	Dual Circuit		Single Circuit	Dual Circuit	
						L1,L2	L3,L4		L1,L2	L3,L4		L1, L2	L3, L4	L1, L2		L3, L4	L1,L2		L3,L4	L1,L2		L3,L4	
EHK05AKN*	5	3.8	1	None	18.1/20.0	—	—	26.0/28.4	—	—	10/10	—	—	10/10	—	—	30/30	—	—	66/66	—	—	
EHK05AKN**	5	3.8	1	None	18.1/20.0	—	—	31.2/33.5	—	—	8/8	—	—	10/10	—	—	35/35	—	—	85/88	—	—	
EHK05AKB*	5	3.8	1	Ckt Bkr	18.1/20.0	—	—	26.0/28.4	—	—	10/10	—	—	10/10	—	—	30/30	—	—	66/66	—	—	
EHK05AKB**	5	3.8	1	Ckt Bkr	18.1/20.0	—	—	31.2/33.5	—	—	8/8	—	—	10/10	—	—	35/35	—	—	85/88	—	—	
EHK07AKN	8	6.0	1	None	28.9/32.0	—	—	44.7/48.5	—	—	8/8	—	—	10/10	—	—	45/50	—	—	59/60	—	—	
EHK07AKB	8	6.0	1	Ckt Bkr	28.9/32.0	—	—	44.7/48.5	—	—	8/8	—	—	10/10	—	—	45/50	—	—	59/60	—	—	
EHK09AKCN†	9	6.8	1	None	32.8/36.0	—	—	49.5/53.5	—	—	8/6	—	—	10/10	—	—	50/60	—	—	54/87	—	—	
	9	6.8	3	None	18.8/20.8	—	—	32.0/34.5	—	—	8/8	—	—	10/10	—	—	35/35	—	—	83/85	—	—	
EHK10AKN	10	7.5	1	None	36.2/40.0	—	—	53.8/58.5	—	—	6/6	—	—	10/10	—	—	60/60	—	—	78/80	—	—	
EHK10AKB	10	7.5	1	Ckt Bkr	36.2/40.0	—	—	53.8/58.5	—	—	6/6	—	—	10/10	—	—	60/60	—	—	78/80	—	—	
EHK15AKF	15	11.3	1	Fuse	54.2/59.9	36.2/40.0	18.1/20.0	76.3/83.4	53.8/58.5	22.7/25.0	4/4	6/6	10/10	8/8	10/10	10/10	80/90	60/60	25/25	88/89	78/80	75/76	
EHK15AKB	15	11.3	1	Ckt Bkr	—	36.2/40.0	18.1/20.0	—	53.8/58.5	22.7/25.0	—	6/6	10/10	—	10/10	10/10	—	60/60	25/25	—	78/80	75/76	
EHK15AHN	15	11.3	3	None	31.3/34.6	—	—	47.7/51.8	—	—	8/6	—	—	10/10	—	—	50/60	—	—	56/90	—	—	
EHK18AHN	18	13.5	3	None	37.6/41.5	—	—	55.5/60.4	—	—	6/6	—	—	10/8	—	—	60/70	—	—	76/77	—	—	
EHK20AKF	20	15.0	1	Fuse	72.3/79.9	36.2/40.0	36.2/40.0	98.9/108.4	53.8/58.5	45.3/50.0	3/2	6/6	8/8	8/6	10/10	10/10	100/110	60/60	50/50	85/109	78/80	59/59	
EHK20AKB	20	15.0	1	Ckt Bkr	—	36.2/40.0	36.2/40.0	—	53.8/58.5	45.3/50.0	—	6/6	8/8	—	10/10	10/10	—	60/60	50/50	—	78/80	59/59	
EHK25AHCF‡	24	18.0	3	Fuse	50.1/55.4	—	—	71.2/77.8	—	—	4/4	—	—	8/8	—	—	80/80	—	—	94/95	—	—	
	24	18.0	1	Fuse	86.7/95.5	—	—	116.9/127.9	—	—	1/1	—	—	6/6	—	—	125/150	—	—	115/116	—	—	
EHK30AHCF‡	30	22.5	3	Fuse	62.6/69.2	—	—	86.8/95.0	—	—	3/3	—	—	8/8	—	—	90/100	—	—	97/98	—	—	
	30	22.5	1	Fuse	109.0/120.0	—	—	144.8/158.5	—	—	0/00	—	—	6/6	—	—	150/175	—	—	117/150	—	—	

FIELD MULTIPOINT WIRING OR 24 AND 30 kW SINGLE PHASE

Heater Model	Heater kW		P H A S E	Heater Amps 208/230V			Minimum Circuit Ampacity 208/230V ★			Minimum Wire Size (AWG) 208/230V‡			Min Gnd Wire Size 208/230V	Max Fuse/Ckt Brk Amps 208/230V			Max Wire Length 208/230V (FT) ††		
	230V	208V		L1, L2	L3, L4	L5, L6	L1, L2	L3, L4	L5, L6	L1, L2	L3, L4	L5, L6		L1, L2	L3, L4	L5, L6	L1, L2	L3, L4	L5, L6
EHK25AHCF‡	24	18.0	1	28.9/32.0	28.9/32.0	28.9/32.0	44.7/48.5	36.2/40.0	36.2/40.0	8/8	8/8	8/8	10/10	45/50	40/40	40/40	59/60	73/73	73/73
EHK30AHCF‡	30	22.5	1	36.2/40.0	36.2/40.0	36.2/40.0	53.8/58.5	45.3/50.0	45.3/50.0	6/6	8/8	8/8	10/10	60/60	50/50	50/50	78/80	59/59	59/59

Notes:

¹ Copper wire must be used. If other than uncoated (non-plated), 75°C ambient, copper wire (solid wire for 10 AWG and smaller, stranded wire for larger than 10 AWG) is used, consult applicable tables of the National Electric Code (ANSI/NFPA 70)

* When used with Fan Coil model sizes 2400, 3600

** When used with Fan Coil model sizes 4200, 4800, 6000

† Includes blower motor amps of largest Fan Coil used with heater

‡ Supplied as single phase, field convertible to 3-phase

‡ Supplied as 3-phase, field convertible to single phase, single or multiple supply circuits

†† Length shown is as measured one way along wire path between unit and service panel for a voltage drop not to exceed 2%

Manufacturer reserves the right to change, at any time, specifications and designs without notice and without obligations.

ACCESSORIES		
Part Number	Description	Use with model size
EBAC01DSC	Disconnect Kit	use with All single phase Heaters 5 kW thru 10 kW
EBAC02NCB	Downflow Base Kit	1800, 2400
EBAC03NCB		3000, 3600, 4200
EBAC04NCB		4800, 6000
EBAC01DFS	Downflow Conversion Kit - Slope Coil	1800, 2400, 3000
EBAC02DFA	Downflow Conversion Kit - "A" Coil	3600, 4200, 4800, 6000
EBAC01SPK	Single Point Wiring Kit	only for use with 15 kW & 20 kW fused heaters
Square D® part # QOU14100JBAF *	Single Point Wiring Kit - Square D® Jumper Bar Assembly	Only for use with EHK15AKB and EHK20AKB breaker heaters
EBAC01FKM	Filter Kit (washable, box of 12) Factory Supplied	1800, 2400
EBAC01FKL		3000, 3600, 4200
EBAC01FKX		4800, 6000
NASA00201FR	Standard Filter Rack (16 x 20 x 1 filter required)	1800, 2400
NASA00301FR	Standard Filter Rack (20 x 20 x 1 filter required)	3000, 3600, 4200
NASA00401FR	Standard Filter Rack [quantity 2] (12 x 20 x 1 filter required)	4800, 6000
EBAC01PLG	No Heat (Plug) Kit (box of 6)	Factory Installed
EBAC01CTK	PVC Condensate Trap Kit (box of 50)	ALL
EBAC01GSK	Horizontal Gasket Kit	ALL (required for horizontal right and downflow)
NAEA20101TX	TXV Kit, R-22, Copper or Tin Coil Only	1800, 2400, 3000, 3600, 4200
NAEA20201TX		4800
NAEA20301TX		6000
NAEB20101TX	TXV Kit, R-22, Aluminum Coil Only	1800AL, 2400AL, 3000AL, 3600AL, 4200AL
NAEB20201TX		4800AL
NAEB20301TX		6000AL
1191140	Door Gasket Kit **	All

* Square D part number given for reference only. Check with local Square D supplier.

** This kit is for replacement of factory installed gaskets if they are damaged or removed from the fan coil.

ELECTRIC HEATERS		
Part Number	Description	Use with Model Sizes
EHK05AKN	5 kW, single phase, no internal circuit protection	ALL
EHK05AKB	5 kW, single phase, with circuit breakers	ALL
EHK07AKN	8 kW, single phase, no internal circuit protection	ALL
EHK07AKB	8 kW, single phase, with circuit breakers	ALL
EHK09AKCN	9 kW, supplied as single phase, field convertible to 3-phase, no internal circuit protection	3600, 4200, 4800, 6000
EHK10AKN	10 kW, single phase, no internal circuit protection	ALL
EHK10AKB	10 kW, single phase, with circuit breakers	ALL
EHK15AKF	15 kW, single phase, with fuses	2400, 3000, 3600, 4200, 4800, 6000
EHK15AKB	15 kW, single phase, with circuit breakers	2400, 3000, 3600, 4200, 4800, 6000
EHK15AHN	15 kW, 3-phase, no internal circuit protection	3600, 4200, 4800, 6000
EHK18AHN	18 kW, 3-phase, no internal circuit protection	4200, 4800, 6000
EHK20AKF	20 kW, single phase, with fuses	3000, 3600, 4200, 4800, 6000
EHK20AKB	20 kW, single phase, with circuit breakers	3000, 3600, 4200, 4800, 6000
EHK25AHCF	24 kW, supplied as 3-phase, field convertible to single phase, with fuses	4800, 6000
EHK30AHCF	30 kW, supplied as 3-phase, field convertible to single phase, with fuses	4800, 6000