



Instruction Sheet

Foam Compensating Low Water Cutoff with Test Button and DualVision™ Technology

102-207

SUPERSEDES: REVISION G DATED December 22, 2008

EFFECTIVE: April 27, 2009

#5401163-REV H

PLANT ID 001-3908



US Patents 6,904,800,
7,243,540, and 7,317,993
Other Patents Pending

Listings/Approvals:

- UL GUIDE (MBPR) for Limit Controls per UL Standard 353 Limit Controls
- UL GUIDE (MCUR2) for Electrode Assemblies - Component
- CUL per CSA Standard C22.2 No.205-M1983
- FM Approved (For applications with a supervised burner management system)
- Fully compliant with CSD-1 requirements

Probe Fitting Thread: 3/4" NPT

Enclosures:

Control Unit – NEMA Type 1 (For indoor use only.) Formed sheet metal with powder coat/plated finish. Five openings for 1/2" conduit fittings.

Maximum Pressures: Steam - 250 psi (17.6kg/cm²)
Hot Water - 250 psi (17.6kg/cm²)

Maximum Probe Temperature: 250° F (121° C)

Maximum Ambient Temperature: 150° F (66° C)

Delays: Delay on Make, (DOM), and Delay on Break, (DOB), automatically provided based upon boiler conditions.

Foam Compensating: The DualVision™ technology provides continuous protection against false water level detection due to probe being in foam. Automatic detection of foaming conditions and shutdown of boiler when water level becomes unsafe. Eliminates intermittent shutdown of the boiler.

Probe Sensitivity: Extended operation to 20K Ohms,
Service range 20K to 40K Ohms

Input Supply Voltage:

Input Voltage	Power Consumption
120 VAC	3 VA
24 VAC**	3 VA

** 24VAC to be supplied by an EXTERNAL Class 2 power source.

Contact Ratings			
Voltage	Motor Switch Rating		Pilot Rating
	Full Load	Locked Rotor	
24 VAC	-	-	50 VA
120 VAC	7.5 A	43.2 A	125 VA
240 VAC	3.75 A	21.6 A	50 or 60 Hz

GENERAL

The Foam Compensating Low Water Cutoffs, (LF series), are advanced, microprocessor based low water cutoffs for detecting the presence of a conductive fluid in a vessel or tank. The LF series is primarily designed for use in low-pressure steam and hot water boilers to cutoff the burner in low water level conditions. They may be used as either the primary or secondary cutoff on low-pressure steam boilers or as the primary low water cutoff on hot water boilers. Additionally, they can protect pumps from running dry in condensate receiver tank applications or activate alarm systems or automatic water feeders. (See each boiler manufacturers' specifications for recommended minimum safe water levels.)

The LF series uses its DualVision™ technology to identify when its probe is in foam and the boiler water is at an unsafe level. The LF series cannot be fooled by the presence of conductive foam on its probe, and it does not require periodic shutdowns of the boiler to determine actual water levels in foaming boilers. The DualVision™

technology also allows the LF series to identify reduced probe signal levels due to fouling and turns on an LED light when the probe should be inspected and cleaned. The LFA models automatically reset when water levels return to safe levels. The LFA control may be used with an alarm or with an automatic water feeder (EWF) to keep the boiler filled to the proper level. The LFM models are manual reset models. Once a low water level has returned to proper levels, the reset switch on the LFM must be pressed to restore the system to normal operation. During a low water condition, the "STATUS" LED will illuminate RED. In normal conditions, it will illuminate GREEN. If the LFA detects foaming, the "SERVICE" LED will blink AMBER. If the LFA detects a low signal level from the probe, the "SERVICE" LED will illuminate AMBER to signal that probe cleaning may be required. (See Fig. 3 for LED operation details).

The LF series will not lock out upon power loss provided water remains covering the probe. They fully comply with CSD-1 requirements.

WARNING

- Installation must be performed by qualified personnel and in accordance with all national and local codes and ordinances.
- Read all instructions carefully and understand them before starting installation. Save instructions for future use.
- Instruct user how to test and operate this cutoff device as described in these instructions.
- Shock Hazard. Disconnect power source before servicing. Serious injury or death could result.
- Risk of explosion. Not for use in hazardous locations. Serious injury or death could result.
- The LWCO device must be installed in series ahead of other limit and operating controls installed on the boiler. When installations are complete, check for correct operation of ALL limit and operating controls.
- Wire insulation must be rated at 167° F (75° C) or greater, over copper conductors only. Use of other wire or insulation types could result in fire causing property damage, serious injury, and death.
- Foam in boiler or piping can cause improper operation. If the boiler is foaming, shutdown the boiler and clean it per the manufacturers recommendations to eliminate foaming. Failure to do so could result in damage to the equipment and property or could cause an explosion resulting in serious injury or death.
- Use only the probe that is supplied with this control or replacement probe P3S-1. Failure to do so could result in improper operation, damage to the equipment and property, or could cause an explosion resulting in serious injury or death.
- Hot or pressurized boiler systems can discharge steam and hot water. Cool boiler system to 80° F (27° C) and to 0 psi (0 bar) before servicing. Failure to do so could result in serious burns.

⚠ CAUTION

- Do not tighten by grasping the device enclosure. Use wrenching flats on the probe bushing only. Failure to install properly could damage the device and cause improper operation resulting in damage to equipment and property.
- Do not use manual reset low water cutoffs with automatic water feeders. Flooding, equipment damage, and property damage can result. Only use automatic water feeders with automatic reset low water cutoffs.

PROBE SPACING REQUIREMENTS

FIG. 1

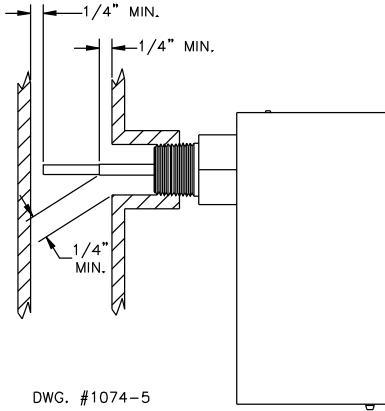

DWG. #1074-5

CONTROL UNIT MOUNTED ON PROBE

FIG. 2

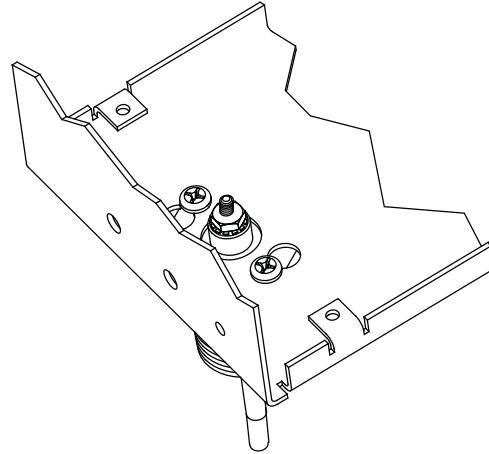

DWG# 1163-9A

⚠ CAUTION

Do not mount device with probe angled upward or deposits can accumulate in the probe. Mount only with probe facing horizontally or vertically downward and maintain 1/4" minimum clearance from electrode and pipe wall. Failure to install probe as directed can cause improper operation and damage to equipment and property.

LWCO

FIG. 3

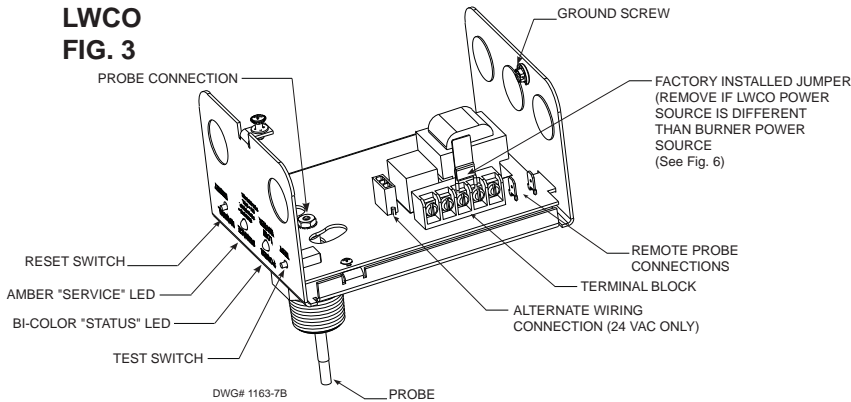

DWG# 1163-7B

LED Indicators

Condition	Status LED	Service LED
Normal	Green	Off
Low Water	Red	Off
Foam Detected, Safe Water Level	Green	Blinking Amber
Foam Detected and Low Water	Red	Blinking Amber
Fouled Probe, Service Soon	Green	Amber
Fouled Probe, Unsafe to Operate	Red	Amber
Control Failure Detected	Blinking Red	Off
Power Off	Off	Off

CONTROL UNIT OUTLINE DWG.

FIG. 4

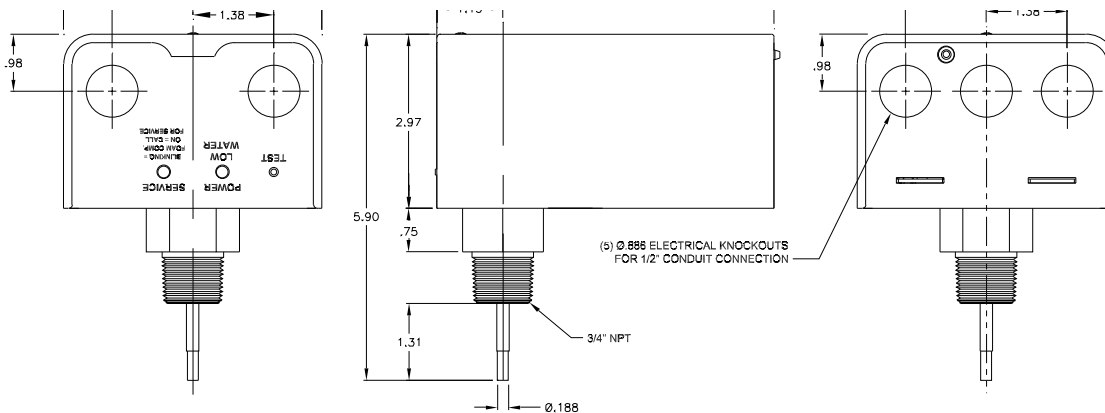

DWG. #1163-4A

Test For Proper Function:

1. DO NOT fill boiler. Set thermostat to lowest possible setting and turn on electric power to the boiler. On initial start-up, the LWCO indicates low water condition, which indicates proper function. The "STATUS" LED on the control unit illuminates RED. The burner **should not** operate without water in the system. During the testing process, the "SERVICE" LED should not be illuminated.
2. Fill boiler with water. Once water covers the probe the "STATUS" LED on the control unit turns from RED to GREEN. You must press the reset button on manual reset models, (LFM models) before the control will reset.
3. Set the thermostat to call for heat, and verify that the burner ignites.
4. Press and hold the **test switch** while observing the LED's on the control unit. The "STATUS" LED illuminates RED and the burner should turn **off**.
5. Testing the burner circuit wiring:
 - a. With the burner aflame, press the **test switch** and observe the burner.
 - b. The burner should **cutoff** after the **test switch** is held. This indicates the burner circuit is wired properly. When test switch is released, the burner ignites and continues functioning (provided water covers the probe). You must press the reset button on manual reset models (FM models) before the control will reset. If burner fails to cutoff or relight, see the Troubleshooting section for details.
6. Set the thermostat to its normal setting.

Once correct operation of the LWCO has been tested, test **ALL** other safety, limit and control devices before finalizing system operation.

Troubleshooting:

1. If the "SERVICE" LED **blinks** AMBER and the "LOW WATER" LED illuminates RED, the LFA has detected excessive foaming in the boiler, resulting in a low water condition. Some foaming is common in certain boilers. If foaming occurs with priming or surging, (usually visible in the gauge glass), this indicates a problem, and that the boiler and piping may be dirty. Refer to the boiler manufacturer's recommendations for cleaning the boiler and piping.
2. If the "SERVICE" LED illuminates AMBER, the probe signal is weak and needs to be cleaned. Scale, oils, or fluxes coating the probe's electrode are insulating the electrode from the LWCO's electrical signals. Remove the probe and thoroughly wipe it with a clean rag. Refill the system and test for proper function.
3. If LWCO fails to cutoff burner during testing:
 - a. Drain the water level in the boiler below the probe.
 - b. Turn off electrical power to the boiler and the LWCO.
 - c. Using an Ohmmeter, measure the resistance between the probe's brass bushing and the nut connection to the probe on the LWCO, (see Fig. 3 for location). If the resistance is less than 5,000 Ohms, then the probe is shorted. The shorted probe must be replaced.

4. If the LWCO fails to function normally, perform the following steps to verify the proper installation:
 - a. Make sure the water level covers the probe.
 - b. Verify **ALL** LWCO wiring and that probe is secured with locknut.
 - c. If Teflon tape was used on the threads of the brass bushing for the probe, remove the tape and install with a small amount of pipe sealant.
 - d. Water treatment may be required.
5. If the "STATUS" LED blinks RED, the safety circuits in the LWCO have detected a failure in the control and the LWCO will remain in a low water condition. To clear any temporary condition:
 - a. Remove power to the LWCO for 30 seconds.
 - b. Re-connect power to the LWCO.
 - c. If the "STATUS" LED continues to blink RED, the safety circuits in the LWCO have found a failure that cannot be corrected. **The control must be replaced.**
6. If water covers the probe and the "STATUS" LED illuminates RED, indicating a low water condition, the probe may be coated with a flux or oils, (the "SERVICE" LED will illuminate AMBER). Add a cleaning solution, (water and trisodium phosphate or consult the boiler manufacturer), to the system. Heat and circulate this solution for at least one hour before draining and completely flushing the system with clean water. Remove the probe and thoroughly wipe it with a clean rag. Refill the system and test for proper function.

Cleaning, Maintenance, and Replacement:

Test the operation of the LWCO annually, or more frequently, by pressing the "TEST" button. The "STATUS" LED should turn RED and the boiler should shut down. Probe must be inspected every 5 years (or sooner if "SERVICE" LED turns on) for scale build-up or coating. Clean all oils, fluxes, and scale from probe with a clean rag.

Probe should be replaced every 10 years. Replace more often if used in areas where heavy water treatment is required, when cleaning is needed more frequent than annually, and/or boiler demands for make-up water are high.

The control unit should be replaced every 15 years. In areas of high humidity and heavy dust or other airborne contaminants more frequent replacement may be required.

PROBE CLEANING

FIG. 10

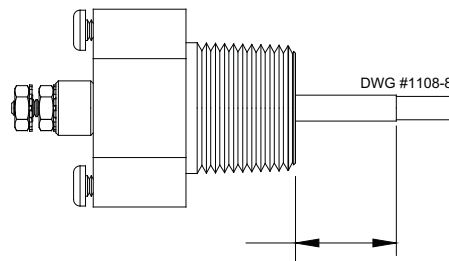

TEFLON SLEEVE INSULATOR
(Be careful not to damage during cleaning)

LWCO Ordering

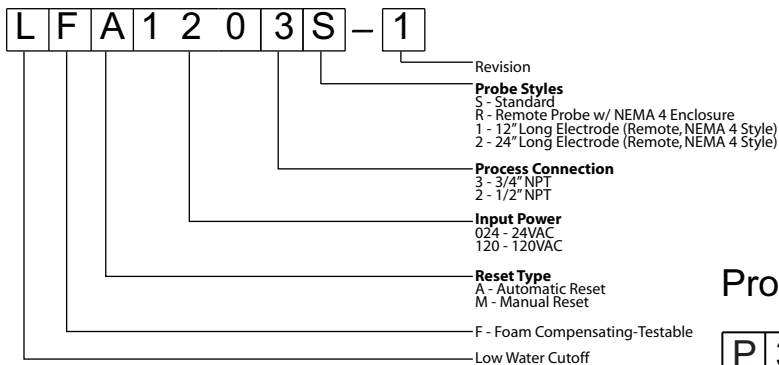

Probe Only Ordering

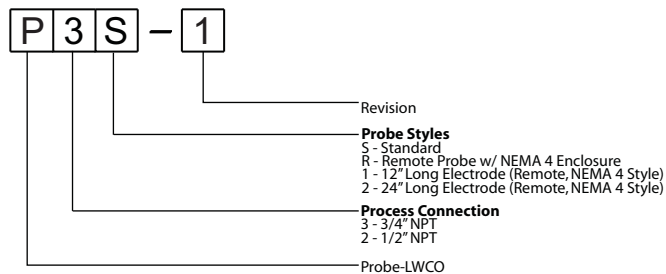

LF SERIES WIRING CROSS REFERENCE

Manufacturer	Device or Series	Power Connections		Output Contacts			Remote Probes	
		Hot	Neutral	Common	To Burner	To Water Feeder/ Alarm	Probe	Probe Reference
Taco	LF & LT Series	H	N	COM	NC	NO	P	GND
McDonnell & Miller	PS-801/851 (Older models w/ red & amber LED's)	1	2	3	5	4	P or J2	Chassis GND
McDonnell & Miller	PS-801/851 (New models w/ red & green LED's)	H	N	C	B	W	J2	Chassis GND
McDonnell & Miller	PS-802/852 (Older models w/ red & amber LED's)	H	N	C	B	W	J7	Chassis GND
McDonnell & Miller	PS-802/852 (New models w/ red & green LED's)	H	N	C	B	W	J3	Chassis GND
McDonnell & Miller	Series 750	1	2	3	4	5	P	Chassis GND
McDonnell & Miller	RB-122	H (Black Wire)	N (White Wire)	C (Yellow Wire)	B (Yellow Wire)	-	-	-
McDonnell & Miller	RB-120	1	2	3	4	5	-	-
McDonnell & Miller	RB-24	Red Wire	White Wire	Yellow Wire	Yellow Wire	-	-	-
Hydrolevel	24	Black Wire	White Wire	-	Orange Wire	Brown Wire	-	-
Hydrolevel	170	H	GN	P1	P2	A	-	-
Hydrolevel	400,500,600,700,450,550,650,750	1	2	P1	P2	A	H3	Chassis GND
Honeywell	RW700 Series (Except RW700A1098)	L1	L2	-	B	A	2 Red Wires, White Wire	Green Wire
Honeywell	RW700A1098	T1	T2	-	B	A	2 Red Wires, White Wire	Green Wire

Limited Warranty Statement

Taco, Inc. will repair or replace without charge (at the company's option) any product or part which is proven defective under normal use within one (1) year from the date of start-up or one (1) year and six (6) months from date of shipment (whichever occurs first).

In order to obtain service under this warranty, it is the responsibility of the purchaser to promptly notify the local Taco stocking distributor or Taco in writing and promptly deliver the subject product or part, delivery prepaid, to the stocking distributor. For assistance on warranty returns, the purchaser may either contact the local Taco stocking distributor or Taco. If the subject product or part contains no defect as covered in this warranty, the purchaser will be billed for parts and labor charges in effect at time of factory examination and repair.

Any Taco product or part not installed or operated in conformity with Taco instructions or which has been subject to misuse, misapplication, the addition of petroleum-based fluids or certain chemical additives to the systems, or other abuse, will not be covered by this warranty.

If in doubt as to whether a particular substance is suitable for use with a Taco product or part, or for any application restrictions, consult the applicable Taco instruction sheets or contact Taco at [401-942-8000]. Taco reserves the right to provide replacement products and parts which are substantially similar in design and functionally equivalent to the defective product or part. Taco reserves the right to make changes in details of design, construction, or arrangement of materials of its products without notification.

TACO OFFERS THIS WARRANTY IN LIEU OF ALL OTHER EXPRESS WARRANTIES. ANY WARRANTY IMPLIED BY LAW INCLUDING WARRANTIES OF MERCHANTABILITY OR FITNESS IS IN EFFECT ONLY FOR THE DURATION OF THE EXPRESS WARRANTY SET FORTH IN THE FIRST PARAGRAPH ABOVE. THE ABOVE WARRANTIES ARE IN LIEU OF ALL OTHER WARRANTIES, EXPRESS OR STATUTORY, OR ANY OTHER WARRANTY OBLIGATION ON THE PART OF TACO.

TACO WILL NOT BE LIABLE FOR ANY SPECIAL, INCIDENTAL, INDIRECT OR CONSEQUENTIAL DAMAGES RESULTING FROM THE USE OF ITS PRODUCTS OR ANY INCIDENTAL COSTS OF REMOVING OR REPLACING DEFECTIVE PRODUCTS.

This warranty gives the purchaser specific rights, and the purchaser may have other rights which vary from state to state. Some states do not allow limitations on how long an implied warranty lasts or on the exclusion of incidental or consequential damages, so these limitations or exclusions may not apply to you.

CONTROLS MADE EASY™

TACO, INC., 1160 Cranston Street, Cranston, RI 02920 Telephone: (401) 942-8000 FAX: (401) 942-2360.

TACO (Canada), Ltd., 6180 Ordan Drive, Mississauga, Ontario L5T 2B3. Telephone: 905/564-9422. FAX: 905/564-9436.

Manufactured by **POTTER ELECTRIC SIGNAL CO.**, St. Louis, MO

Visit our web site at: <http://www.taco-hvac.com>

Printed in USA

Copyright 2008

TACO, Inc.