



**WARNING:**  
These installation instructions may only be used by trained fitters and service technicians. Read all instructions before installing. Perform steps exactly in the order given. Failure to follow these instructions can result in severe injury, death or property damage.



# Installation and Maintenance Instructions

## Logalux

LT160/1  
LT200/1  
LT300/1

6 720 811 745 (2015/07) US/CA

Read carefully before installation and servicing.

**Buderus**

**Contents**

<b>1</b>	<b>Safety Considerations and Symbol Descriptions</b>	<b>3</b>	<b>9</b>	<b>Maintenance</b>	<b>15</b>
1.1	Key to symbols	3	9.1	Preparing the DHW tank for cleaning	15
1.2	Safety instructions	3	9.2	Descaling/cleaning the tank	15
1.3	Instructions for the owner and operator	4	9.3	Checking the magnesium anode	16
			9.3.1	Testing with the anode tester	16
			9.3.2	Visual check	16
			9.3.3	Replacing the magnesium anode	16
			9.4	Startup after maintenance	17
<b>2</b>	<b>Product Information</b>	<b>5</b>	<b>10</b>	<b>Spare Parts</b>	<b>18</b>
2.1	Scope of delivery	5			
2.2	Designated use	5			
2.3	Product Information	6			
2.4	Data plate	6			
2.5	Pressure drop curve of heating coil	6			
2.6	Technical Data	7			
2.7	Physical and connection dimensions	8			
<b>3</b>	<b>Standards, regulations and directives</b>	<b>9</b>			
<b>4</b>	<b>Moving the tank</b>	<b>9</b>			
<b>5</b>	<b>Installation</b>	<b>10</b>			
5.1	Tank installation	10			
5.1.1	Requirements for installation location	10			
5.1.2	Wall clearances	10			
5.1.3	Positioning the tank	10			
5.2	Water connections	11			
5.2.1	Connecting the tank on the water side	11			
5.2.2	Installing B-kit components	12			
5.2.3	Installing a T&P safety valve (provided by the customer)	12			
5.3	Install a tank water temperature sensor (accessory) or aquastat (accessory)	12			
5.3.1	Logamatic controller	12			
5.3.2	Installing the DHW tank temperature sensor	12			
5.3.3	Installing the aquastat	13			
5.3.4	Fitting the thermal insulation and front panel	13			
<b>6</b>	<b>Start-up procedure</b>	<b>14</b>			
6.1	Commissioning the DHW tank	14			
<b>7</b>	<b>Shutdown</b>	<b>14</b>			
7.1	Shutting down the tank	14			
7.2	Shutting down the heating system when there is a risk of frost	14			
<b>8</b>	<b>Environmental Protection / Disposal</b>	<b>14</b>			

## 1 Safety Considerations and Symbol Descriptions

### 1.1 Key to symbols

#### Warnings



Warnings in this document are indicated by a warning triangle printed against a gray background. Keywords at the start of a warning indicate the type and seriousness of the ensuing risk if measures to prevent the risk are not taken.

The following keywords are defined and can be used in this document:

- **NOTICE** is used to address practices not related to personal injury.
- **CAUTION** indicates a hazardous situation which, if not avoided, could result in minor to moderate injury.
- **WARNING** indicates a hazardous situation which, if not avoided, could result in death or serious injury.
- **DANGER** indicates a hazardous situation which, if not avoided, could result in death or serious injury.

#### Important Information



This symbol indicates important information where there is no risk to people or property.

#### Additional symbols

Symbol	Function
▶	Sequence of steps
→	Cross-reference to another part of the document
•	Listing/list entry
–	Listing/list entry (2nd level)

Table 1

### 1.2 Safety instructions

Read all instructions before installing. Perform the steps in the indicated sequence. Have the DHW tank inspected by a trained service technician at least once every year. Failure to comply with these instructions can result in severe, possibly fatal, personal injury as well as damage to property and equipment.

#### Installation and servicing

##### ▶ Risk of fire from soldering and brazing!

Take appropriate safety measures when soldering and brazing as the thermal insulation is flammable.

- ▶ Ensure that only a licensed contractor installs or services the DHW tank.
- ▶ Use installation material with adequate temperature stability.

#### Forbidden:

Connection of the potentiostat for an impressed current anode to the magnesium anode installed in a storage tank is absolutely forbidden! This would destroy the tank! The warranty would be voided.

#### Installation and commissioning

- ▶ In the Commonwealth of Massachusetts, the DHW tank must be installed by a licensed plumber.
- ▶ Have an electrician connect the electrical system. The wiring diagram must be followed.
- ▶ Do not install this device in rooms with a high moisture level (e.g. bathrooms, saunas).

#### Function

- ▶ To ensure that the tank functions properly, heed these installation and maintenance instructions.
- ▶ Never close the blow-off line of the T&P safety valve. For safety reasons, water may escape during heating.

#### Danger from electric shock

- ▶ Only electricians may work on the electrical system.
- ▶ Before performing electrical work, disconnect the power cable and secure the unit against unintentional reconnection.
- ▶ Ensure the system has been disconnected from the power supply.

#### Risk of scalding at the hot water draw-off point

- ▶ When the DHW tank is in operation, temperatures in excess of 122 °F (50 °C) can occur. To limit the temperature at the tap, install a thermostatic DHW mixing valve.
- ▶ Water heated for washing the laundry, dishes and for other cleaning purposes can cause scalding and permanent injuries.
- ▶ Children, elderly, and mentally impaired persons are more likely to be permanently injured by hot water. Never leave such individuals in the tub or shower unattended under any circumstances. Children must not be allowed to operate hot water faucets themselves or to fill a bathtub.
- ▶ If the building has occupants in the above groups who operate hot water faucets, or state laws / local ordinances stipulate specific water temperatures, take the following precautions:
  - Use the lowest possible temperature setting.
  - To prevent scalding, install a tempering device, such as an automatic mixing valve, at hot water tap or water heater. Select and install the automatic mixing valve in accordance with the valve manufacturer's recommendations and instructions.
- ▶ Water exiting from drain valves can be extremely hot. To avoid injuries:
  - Check that all connections are tight.
  - Direct exiting water away from people.
- ▶ Measures must be taken to protect against excessive temperature and pressure! Installation of a T&P safety valve is required.

The chart below shows the relationship between water temperature and time until there is a risk of scalding. It can be used as the basis for determining the safest water temperature for your application.

Temperature	Time to severe scalding
120 °F (48 °C)	> 5 min
125 °F (51 °C)	1.5...2 min
130 °F (54 °C)	~ 30 s
135 °F (57 °C)	~ 10 s
140 °F (60 °C)	< 5 s
145 °F (62 °C)	< 3 s
150 °F (65 °C)	~ 1.5 s
155 °F (68 °C)	~ 1 s

Table 2 Time-temperature relationship until there is a risk of scalding (approximate values)<sup>1)</sup>

1) Source: Moritz, A.R. and Henriques, F.C., Jr. (1947). Studies of thermal injury. II. The relative importance of time and surface temperature in the causation of cutaneous burns, Am J of Pathol, 23, 695-720.

To protect against corrosion and ensure compliance with the rules for electrical safety, observe the following points:

- ▶ Use metal fittings for drinking water heating systems with plastic piping.
- ▶ Use only original accessories from the manufacturer.
- ▶ When installation of the tank is complete, inspect the ground conductor (including metal fittings).

**Maintenance**

**Customers are advised to:**

- ▶ Sign a maintenance and inspection contract with an authorized contractor. Inspect and maintain the DHW tank as necessary on a yearly basis. Service as needed.
- ▶ Use only original spare parts.

**Flooding**

- ▶ After a flood, do not use the appliance if any part has been submerged. Damage to appliances that have been submerged can be quite severe and pose numerous safety risks.
- ▶ An appliance that was subject to flooding must be replaced.

**1.3 Instructions for the owner and operator**



**WARNING:** Risk of scalding at the taps!  
There is a risk of scalding at the taps if the tank temperature is set above 122 °F (50 °C) and during thermal disinfection.

- ▶ Advise users that they should draw off only mixed water. Otherwise, install a thermostatic DHW mixing valve.



**NOTICE:** Risk of tank damage from excessively high pressure.

- ▶ Never plug the blow-off line of the T&P safety valve.

- ▶ Explain the operation and handling of the heating system and DHW tank, making a particular point of safety-relevant features.
- ▶ Explain the function and how to check the T&P safety valve.
- ▶ Hand all enclosed documents over to the owner/operator.
- ▶ **Recommendation for the user:** Sign a maintenance and inspection contract with a licensed contractor.
- ▶ Highlight the following for the user:
  - Water may be discharged from the T&P safety valve during heat-up.
  - The blow-off line on the T&P safety valve must always be kept open.
  - Check that the T&P safety valve operates properly at least once yearly.
  - The tank must be inspected annually and maintained as required.

## 2 Product Information

### 2.1 Scope of delivery

- DHW tanks
- Installation and Maintenance Instructions
- B-KIT

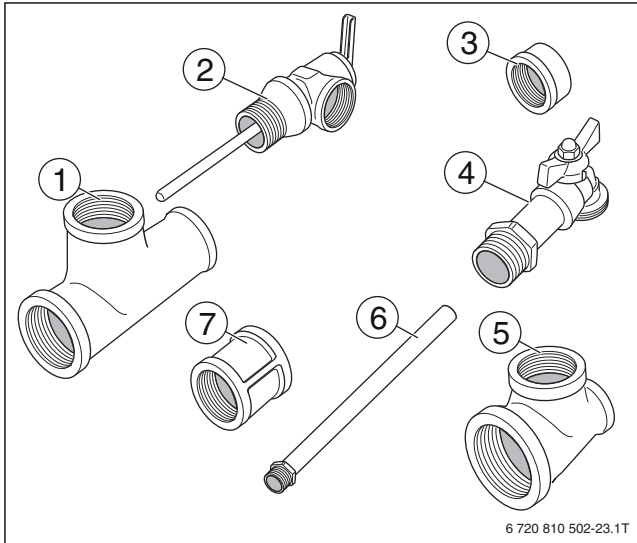

Fig. 1 B-kit

- [1] Tee 1" x 1" x ¾"
- [2] Temperature and pressure relief valve
- [3] Cap ¾"
- [4] Drain valve
- [5] Tee 1¼" x 1" x ¾"
- [6] Sensor Well
- [7] Coupling ¾"

### 2.2 Designated use

The tank is designed for heating and storing drinking water. Please observe national, regional, and local codes, regulations, guidelines and standards for drinking water.

Install this tank only in sealed unvented hydronic heating systems.

Any other purpose is considered improper use. Any resulting damage is excluded from the manufacturer's warranty.

Requirements for potable water	Unit	
Water hardness	ppm	≥ 36
	grain/US gallon	≥ 2.1
	°dH	≥ 2
pH value		≥ 6.5...≤ 9.5
Conductivity	µS/cm	≥ 130...≤ 1500

Table 3 Requirements for potable water

2.3 Product Information

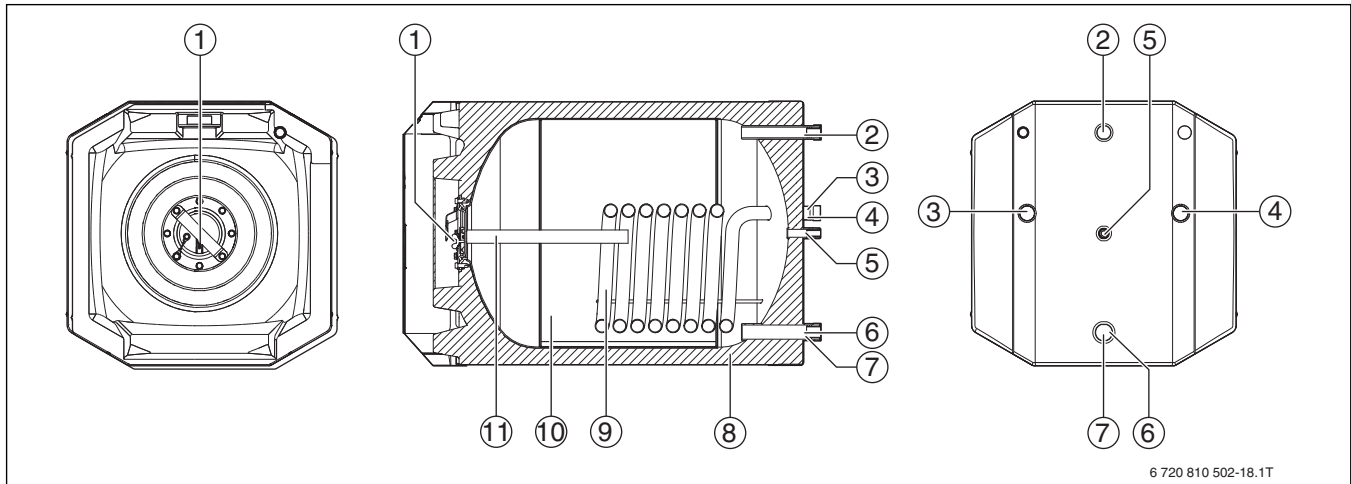

Fig. 2 Product Information

Item	Description
1	Inspection port for service and cleaning
2	DHW outlet
3	DHW tank return
4	DHW tank supply
5	Recirculation connection (or aquastat installation)
6	Tank drain
7	Cold water inlet
8	Casing, painted sheet metal with rigid polyurethane foam insulation
9	Heat exchanger for heating by boiler, smooth enameled tubing
10	Tank, enameled steel
11	Electrically insulated magnesium anode installed in inspection port

Table 4 Product Information

2.4 Data plate

The data plate is located at the top rear of the DHW tank.

2.5 Pressure drop curve of heating coil

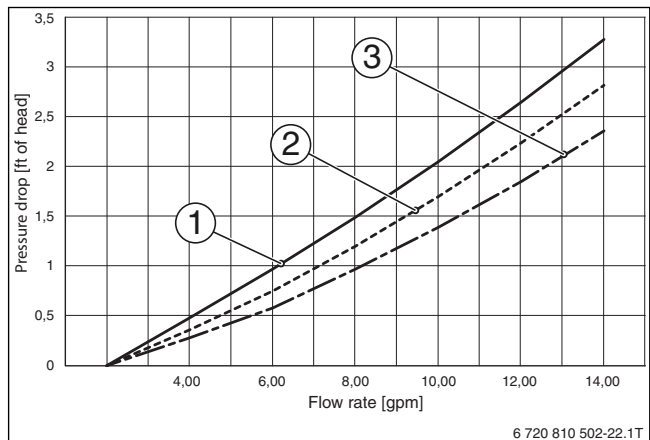

Fig. 3 Pressure drop diagram

- [1] LT300/1
- [2] LT200/1
- [3] LT160/1

## 2.6 Technical Data

	Unit	LT160/1	LT200/1	LT300/1
<b>Tank capacity</b>				
Tank capacity (total)	gal (l)	42.6 (160)	52.5 (200)	76 (300)
Maximum flow rate	gpm (l/min)	4.3 (16)	5.3 (20)	7.6 (30)
Maximum hot temperature (on the domestic hot water side)	°F (°C)	203 (95)	203 (95)	203 (95)
Maximum operating pressure DHW	psi (bar)	150 (10.3)	150 (10.3)	150 (10.3)
Stand-by heat loss (at 149 °F (65 °C) hot water temperature and 68 °F (20 °C) room temperature)	°F/h (K/h)	0.63 (0.27)	0.63 (0.25)	0.39 (0.20)
<b>DHW tank performance at:</b>				
Domestic cold water inlet temperature	°F (°C)	50 (10)	50 (10)	50 (10)
Domestic hot water outlet temperature	°F (°C)	140 (60)	140 (60)	140 (60)
DHW temperature rise	°F (°C)	90 (50)	90 (50)	90 (50)
Heat exchanger supply temperature (heating water)	°F (°C)	176 (80)	176 (80)	176 (80)
Flow rate (heating water)	gpm (l/h)	14 (3180)	14 (3180)	14 (3180)
Pressure drop (heating water)	foh (mbar)	2.4 (71)	2.8 (84)	3.2 (98)
Continuous rating	gph (l/h) gpm (l/min)	122 (461) 2.03 (7.7)	128 (486) 2.13 (8.1)	208 (787) 3.50 (13.1)
Amount that can be drawn off in the first hour	gph (l/h)	163 (614)	176 (667)	276 (1046)
Maximum heat input	btu/hr (kW)	76,086 (22.3)	82,985 (24.3)	126,323 (37.0)
<b>Heat exchanger</b>				
Content	gal (l)	1.7 (6.4)	1.9 (7.2)	3.2 (12.1)
Surface area	ft <sup>2</sup> (m <sup>2</sup> )	8.72 (0.81)	10.01 (0.93)	16.15 (1.50)
Maximum heating water temperature	°F (°C)	230 (110)	230 (110)	230 (110)
Max. operating pressure, heat exchanger	psi (bar)	232 (16)	232 (16)	232 (16)

Table 5 Technical Data

2.7 Physical and connection dimensions

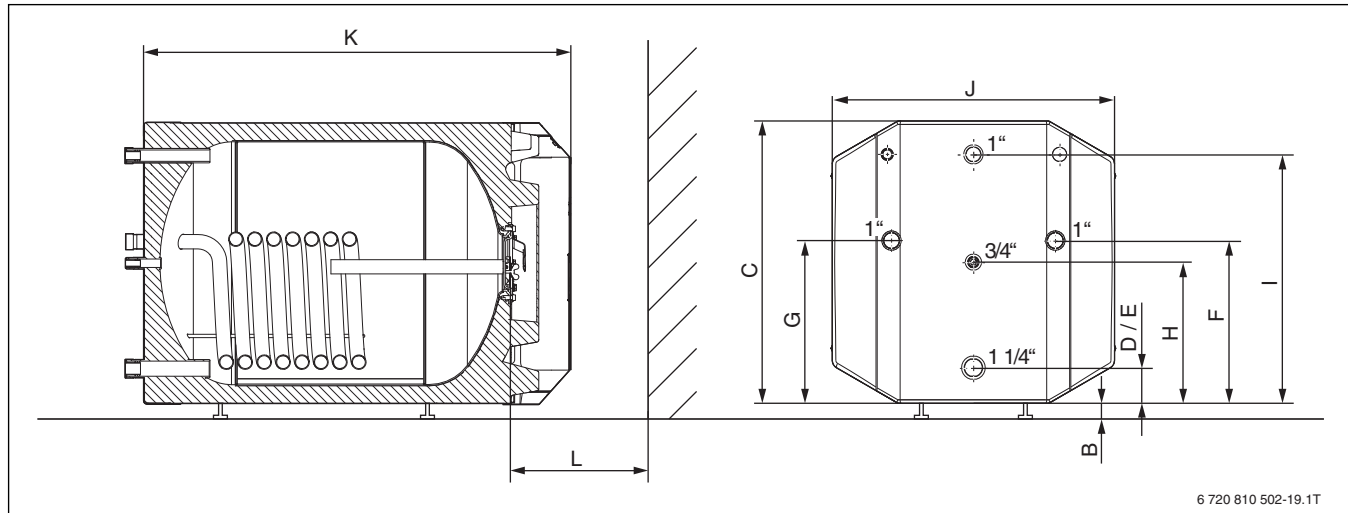

Fig. 4 Dimensions and Connections

Item	Description	Unit	LT160/1	LT200/1	LT300/1
A	Minimum floor weight carrying capacity	lb (kg)	551 1/7 (250)	690 (313)	976 2/3 (443)
B	Clearance off floor	inch (mm)	1/2 (12.5)	1/2 (12.5)	1/2 (12.5)
C	Height, storage tank without feet	inch (mm)	25 3/4 (656)	25 3/4 (656)	25 3/4 (656)
D	Height, cold water inlet	inch (mm)	3 1/4 (83)	3 1/4 (83)	3 1/4 (83)
E	Height, drain connection	inch (mm)	3 1/4 (83)	3 1/4 (83)	3 1/4 (83)
f	Height, storage tank return connection	inch (mm)	15 (378)	15 (378)	15 (378)
G	Height, storage tank supply connection	inch (mm)	15 (378)	15 (378)	15 (378)
H	Height, recirculation connection	inch (mm)	13 (328)	13 (328)	13 (328)
I	Height, hot water outlet	inch (mm)	22 3/4 (578)	22 3/4 (578)	22 3/4 (578)
J	Width	inch (mm)	26 (659)	26 (659)	26 (659)
K	Depth	inch (mm)	39 (992)	45 1/7 (1147)	60 1/2 (1537)
L	Space required in front of storage tank for anode replacement	inch (mm)	40 (1016)	40 (1016)	40 (1016)
V	Weight, empty	lb (kg)	185 (84)	233 1/2 (106)	291 (132)
M	Weight, full (including heating coil contents)	lb (kg)	551 1/7 (250)	690 (313)	976 2/3 (443)

Table 6 Physical and connection dimensions



### 3 Standards, regulations and directives



Observe all national, state, and local codes, regulations and standards applicable to installation and operation of the tank!



All electrical components must be approved for the USA and Canada.

### 4 Moving the tank



**WARNING:** Risk of injury from carrying heavy loads and inadequately securing loads for transport!

- ▶ Use suitable means of transportation, e. g. a dolly with strap.
- ▶ Secure the load against falling.

To protect the storage tank during transport:

- ▶ Move the DHW tank to its installation location while completely packed.
- ▶ Position the dolly at the back of the DHW tank.
- ▶ Secure the DHW tank to the means of transportation with a strap.
- ▶ Transport the DHW tank to the installation location.
- ▶ Remove the DHW tank from the packaging only at the installation location.

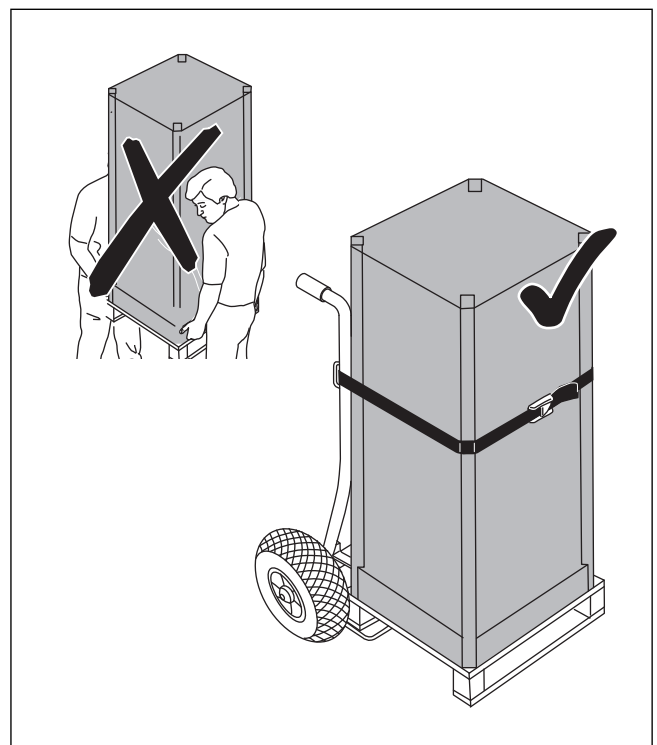

Fig. 5 Transporting with a dolly

## 5 Installation

The tank is delivered fully assembled.

- ▶ Check that the tank is complete and undamaged.

### 5.1 Tank installation

#### 5.1.1 Requirements for installation location



The material for positioning and fastening the floor-standing boiler to the DHW tank is included in the scope of delivery of the boiler-storage tank connecting line.



**NOTICE:** Risk of damage from inadequate load-bearing capacity of the supporting substructure or unsuitable floor surface!

- ▶ Ensure that the installation area is level and offers sufficient load-bearing capacity.



**NOTICE:** Risk of damage from stress cracking and corrosion!

- ▶ Position the DHW tank in a dry room free from the risk of freezing.
- ▶ Install the tank only in closed-loop, unvented hydronic heating systems.
- ▶ Never use open, vented expansion vessels for this DHW tank.



**NOTICE:** If leaks can result in property damage or a drain pan is required by law:

- ▶ Install an adequate drain pan.
- ▶ Follow the installation instructions of the drain pan manufacturer.

- ▶ Place the DHW tank on a plinth if there is a risk that water may collect at the installation site.
- ▶ The installation site must be a dry and frost-free room.
- ▶ Observe minimum wall clearances at installation location (→ Fig. 6).
- ▶ Maintain a clearance of 2" (51 mm) from heated pipes and combustible surfaces.

#### 5.1.2 Wall clearances

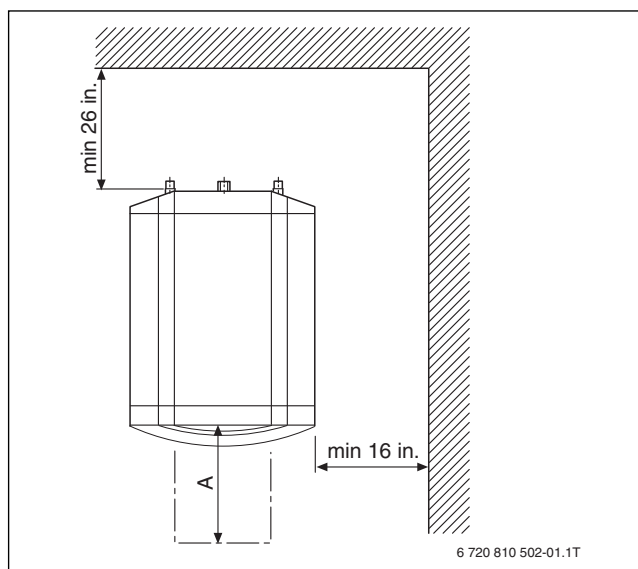

Fig. 6 Recommended minimum wall clearances (illustrative)

#### 5.1.3 Positioning the tank

- ▶ Cut the packaging film on the side opposite the "Tank top" sticker (→ Fig. 7).
- ▶ Remove only the film you have cut out.
- ▶ Thread the 4 adjustable feet supplied [1] ~ 0.6...1 inch into the threaded bushings provided for this purpose.
- ▶ Remove the wooden corner strips [3] from the tank underside.

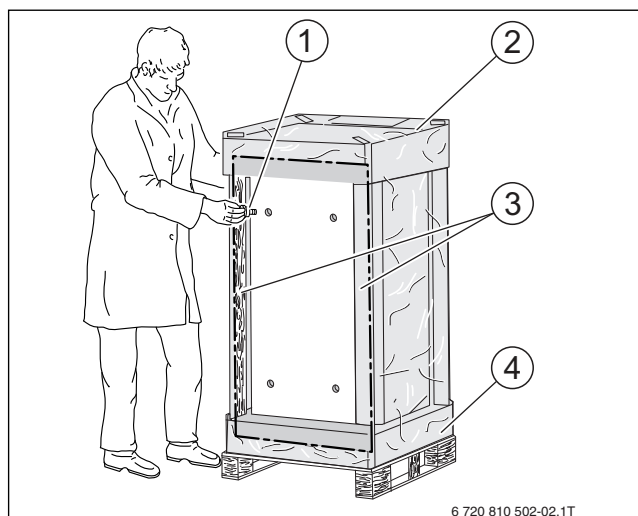

Fig. 7 Cutting the packaging film and inserting the adjustable feet

- [1] Adjustable feet
- [2] Rear end of tank
- [3] Wooden corner strips
- [4] Front end of tank

- ▶ Tip the DHW tank over on the edge of the pallet and set it on its feet (→ Fig. 8).
- ▶ Remove the remaining film, bottom and top of packaging and wooden pallet. Raise the front and rear of the DHW tank slightly if necessary to do this.



Fig. 8 Positioning the tank

- ▶ Position the DHW tank on a level floor with adequate load-bearing capacity.
- ▶ By turning the adjustable feet, incline the tank slightly toward the back (→ Fig. 9).

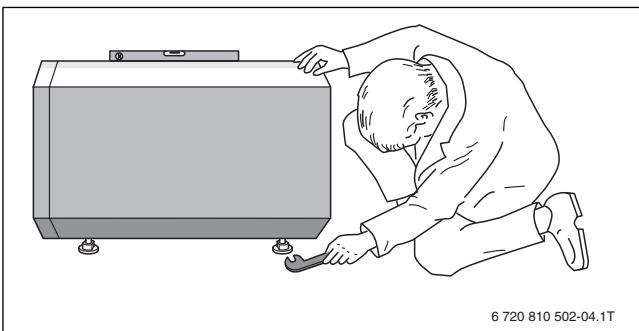

Fig. 9 Leveling the DHW tank (illustrative)

- ▶ Maintain minimum wall clearances.
- ▶ Remove the caps from the connections.
- ▶ Use Teflon tape or Teflon cord to seal the connections. Do not use hemp to seal the connections.

## 5.2 Water connections



**DANGER:** Risk of injury from contaminated water!  
Work carried out without due care for cleanliness contaminates the drinking water.

- ▶ Install in accordance with national standards and guidelines.



**WARNING:** Risk of fire from soldering and welding!  
Take appropriate protective measures when soldering and welding as the thermal insulation is combustible (for example, cover the thermal insulation).

- ▶ Check tank jacket for damage after completing work.



**NOTICE:** Water damage!  
▶ Connect the drain to the bottom tank connection prior to filling the tank.  
▶ Seal off all unused tank connections.



**NOTICE:** Risk of corrosion from damage to the enamel coating!  
▶ Attach connections to the DHW tank only "hand-tight".

### 5.2.1 Connecting the tank on the water side

System example with all recommended valves and shut-offs (→ Fig. 10).

- ▶ When sizing the heating system expansion vessel, take the volume of the heating coil in the tank into consideration.
- ▶ Install piping runs so that natural circulation is prevented. If necessary, install check valves.
- ▶ Install all pipes free of stress.
- ▶ Attach piping to the tank connections on-site.
- ▶ Check all connections for leaks.

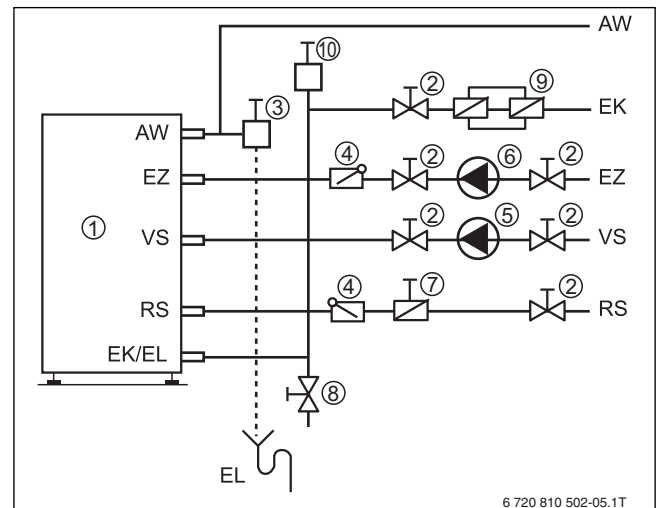

Fig. 10 Installation (illustrative)

- AW DHW outlet
- EK Cold water inlet
- EL Tank drain
- EZ Recirculation inlet or aquastat installation
- RS DHW tank return
- VS DHW tank supply

- [1] Storage tank
- [2] Shutoff valve
- [3] Safety valve
- [4] Check valve
- [5] Tank primary pump
- [6] Recirculation pump (optional)
- [7] Air eliminator (in main supply)
- [8] Drain valve
- [9] Backflow preventer
- [10] Expansion vessel

### 5.2.2 Installing B-kit components

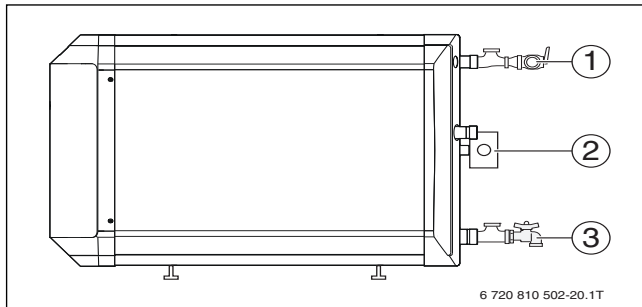

Fig. 11 Installing B-kit components

- [1] Tee 1" x 1" x 3/4" (2x) with P&T safety valve
- [2] Aquastat
- [3] Tee with fill and drain valve

### 5.2.3 Installing a T&P safety valve (provided by the customer)

- ▶ Install a listed T&P safety valve that is approved for drinking water ( $\geq 3/4"$ ) in the DHW outlet.
- ▶ The DHW tank must be installed with a new T&P safety valve.
- ▶ Ensure that the T&P valve is sized no smaller than the rated tank capacity.
- ▶ Observe the safety valve installation instructions.
- ▶ Observe the following when installing the blow-off line for the T&P valve:
  - The blow-off line must be at least equal to the outlet cross-section of the safety valve.
  - Route the blow-off line from the T&P valve directly to an adequate drain (maximum length 6 ft (2 m) with no more than two 90°-elbows).
  - The blow-off line must terminate at an adequate drain in order to prevent property damage from spillage.
  - Check that the T&P safety valve operates properly at least once annually.
- ▶ Never plug the blow-off line. During heating, water may be discharged for operational reasons at any time.

### 5.3 Install a tank water temperature sensor (accessory) or aquastat (accessory)

The DHW tank temperature sensor or aquastat is used to measure and monitor the hot water temperature of the DHW tank.



**DANGER:** Risk of fatal injury from electric shock.

- ▶ Disconnect electrical power completely from the heating system and lock the disconnect switch to prevent accidental reconnection.

#### 5.3.1 Logamatic controller

If a Logamatic controller is used:

- ▶ Install a DHW tank temperature sensor or an aquastat on the DHW tank to measure and monitor the hot water temperature.

#### 5.3.2 Installing the DHW tank temperature sensor



Electrical installation and the temperature setting for the DHW tank temperature sensor or aquastat are described in the respective instructions included with the controller and/or boiler.

- ▶ Take the tank temperature sensor from the scope of delivery of the control panel (accessories).
- ▶ Remove front cover of tank (→ Fig. 12 [1]).
- ▶ To do so, loosen the 4 screws [3] on the sides of the front cover.
- ▶ Remove front cover of tank [1] and the thermal insulation element [2].

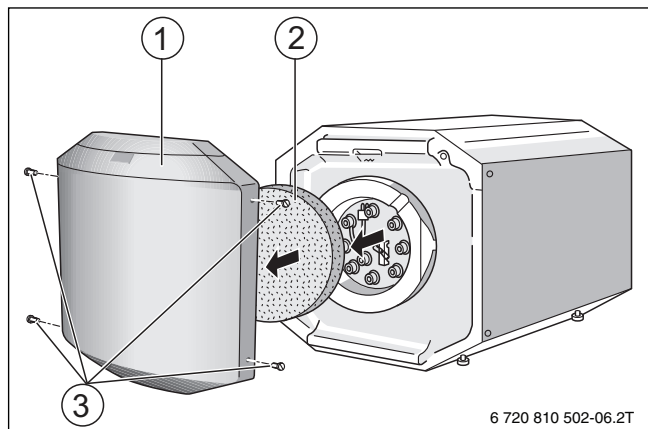

Fig. 12 Removing the front panel and thermal insulation

- [1] Front cover of tank
- [2] Thermal insulation element
- [3] Attachment screws

A conduit is encapsulated in the tank's foam thermal insulation; the DHW tank temperature sensor can be inserted here.

- ▶ Insert the DHW tank temperature sensor (→ Fig. 13 [1]) into the conduit [2] at the rear of the tank.
- ▶ For a type LT300/1: Extend sensor lead with an extension cable (not included in scope of delivery) and push toward the front.
- ▶ Fit the temperature sensor to the sensor clamp as required by its shape.

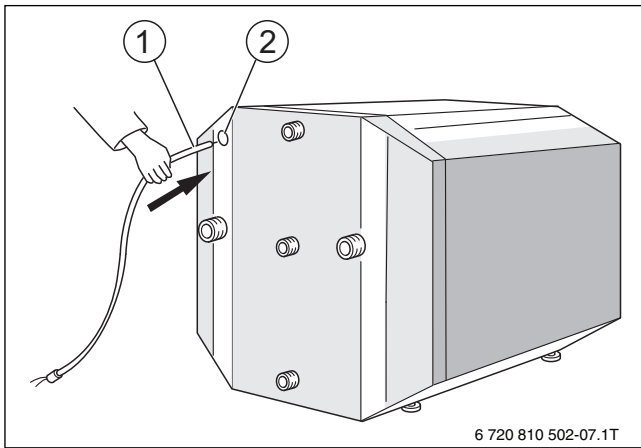

Fig. 13 Fitting sensors

- [1] Temperature sensor
- [2] Conduits



To ensure reliable temperature transmission:

- ▶ Ensure good contact of the sensor surfaces in the sensor clamp.

Electrical installation of the temperature sensor is described in the documents supplied with the controller and the boiler.

### 5.3.3 Installing the aquastat

- ▶ Install the brass sleeve NPT 3/4" and sensor (→ Fig. 14 [1]) that come with the delivery onto the EZ connection.
- ▶ Insert the capillary sensor [3] of the aquastat [2] together with the compensating spring [4] into the sensor well.
- ▶ Secure the aquastat in the sensor well.

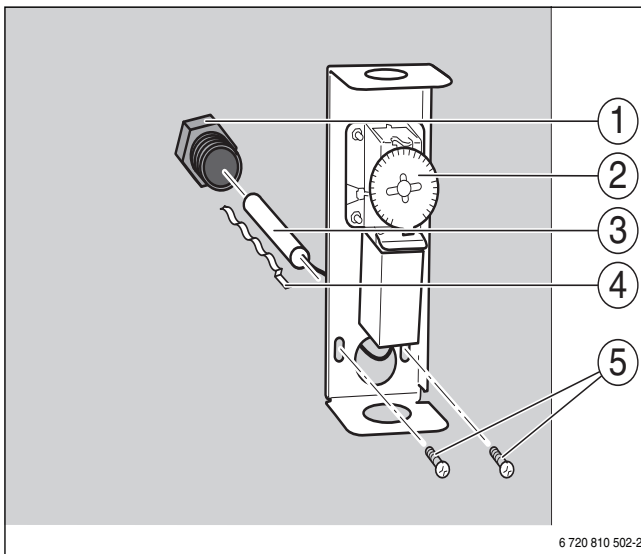

Fig. 14 Installing the aquastat

- [1] Sensor Well
- [2] Aquastat
- [3] Capillary sensor
- [4] Compensating spring
- [5] Attachment screws

### 5.3.4 Fitting the thermal insulation and front panel

- ▶ Place the thermal insulation element (→ Fig. 15 [2]) in front of the handhole cover.
- ▶ Replace front cover of tank [1] and fasten with 4 screws [3].

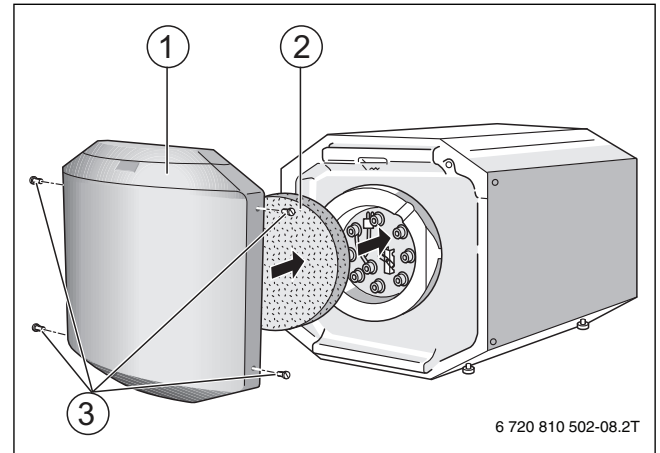

Fig. 15 Fitting the thermal insulation and front cover

- [1] Front cover of tank
- [2] Thermal insulation element
- [3] Attachment screws

## 6 Start-up procedure



**NOTICE:** Risk of equipment damage from excess pressure!

Excessive pressure can result in stress cracks in the enamel coating.

- ▶ Never plug the blow-off line of the T&P safety valve.

### 6.1 Commissioning the DHW tank

Have the installer of the heating system or a qualified contractor commission the equipment.

- ▶ Commission the boiler and additional accessories in accordance with manufacturer's instructions or the appropriate installation and operating instructions.



Use only drinking water to check the DHW tank for leaks. The test pressure on the DHW side must not exceed 150 psi (10.3 bar).

To bleed the DHW tank:

- ▶ Open the highest faucet.
- ▶ Open the cold water inlet shut-off valve.

Before commissioning:

- ▶ Flush the DHW tank and piping thoroughly.
- ▶ Verify that the boiler, DHW tank and piping are filled with water. Open the air bleeder valve for this purpose.
- ▶ Check all connections, piping and the inspection port for leaks.

## 7 Shutdown



**NOTICE:** Risk of tank damage from residual moisture! To prevent corrosion from residual moisture:

- ▶ Dry the interior thoroughly (e. g. with hot air).
- ▶ Leave the handhole cover open.

### 7.1 Shutting down the tank

- ▶ Switch off the temperature controller at the control unit.
- ▶ Switch off the heating system emergency shutoff switch, or disengage the heating system circuit breaker.



**WARNING:** Risk of scalding from hot water!

- ▶ Let the tank cool down sufficiently.

- ▶ Close the cold water inlet shutoff valve.
- ▶ Drain the DHW tank by means of the drain valve. To do so, open the highest faucet.
- ▶ Close the shut-off valves to and from the boiler.
- ▶ Depressurize the heat exchanger.
- ▶ Drain and blow out the heat exchanger.
- ▶ Dry the interior thoroughly (e. g. with hot air).
- ▶ Leave the handhole cover open.

### 7.2 Shutting down the heating system when there is a risk of frost

- ▶ Shut down the heating system and the DHW tank as shown in Chapter 7.1.



Fully drain the tank – even the lowest section of the tank and the heating coil.

## 8 Environmental Protection / Disposal

Environmental protection is one of the fundamental company policies of the Bosch Group.

Quality of products, efficiency and environmental protection are equally important objectives for us. Environmental protection laws and regulations are strictly observed.

To protect the environment, we use the best possible technology and materials, taking into account economic points of view.

### Packaging

For the packaging, we participate in the country-specific recycling systems, which guarantee optimal recycling. All packaging materials used are environmentally-friendly and recyclable.

### Old electrical and electronic appliances



Electrical or electronic devices that are no longer serviceable must be collected separately and sent for environmentally compatible recycling (in accordance with the European Waste Electrical and Electronic Equipment Directive).

To dispose of old electrical or electronic devices, you should use the return and collection systems put in place in the country concerned.

## 9 Maintenance

- ▶ Allow the DHW tank to cool down sufficiently before performing any maintenance.
- ▶ Remedy all faults immediately.
- ▶ Use original spare parts only!
- ▶ The tank must be inspected annually and maintained as required.
- ▶ Check the T&P safety valve annually.

### 9.1 Preparing the DHW tank for cleaning



**WARNING:** Risk of scalding from hot water!  
Hot water can cause scalding.

- ▶ Prior to cleaning, allow the DHW tank to cool down sufficiently.

- ▶ Disconnect electrical power from the heating system.
- ▶ Remove front cover of tank (→ Fig. 12 [1], page 12).
- ▶ To do so, loosen the 4 screws [3] on the sides of the front cover.
- ▶ Remove front cover of tank [1] and the thermal insulation element [2].
- ▶ Drain the DHW tank.
- ▶ To do so, close the shut-off valve for cold water inlet and the open drain valve.
- ▶ To vent the system, open the air vent valve or the highest faucet.

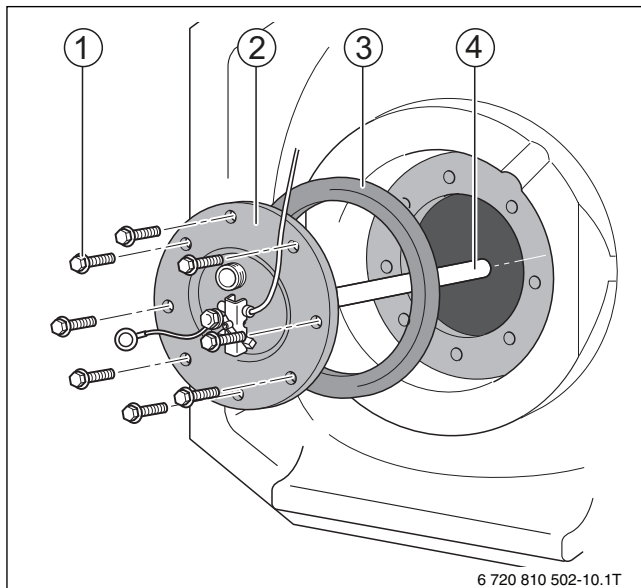

Fig. 16 Removing the cleanout cover

- [1] Hex bolts
- [2] Handhole cover
- [3] Handhole cover gasket
- [4] Magnesium anode

- ▶ Unscrew the hex bolts (→ Fig. 16 [1]) from the handhole cover [2].
- ▶ Remove the handhole cover together with the handhole cover gasket [3] and the magnesium anode [4] from the DHW tank.

### 9.2 Descaling/cleaning the tank

- ▶ Check the DHW tank interior for scale deposits (calcium).



**NOTICE:** Risk of tank damage due to damaged enamel.

- ▶ Never use hard objects or tools with sharp edges to clean the interior of the tank

If scale deposits have formed in the DHW tank:

- ▶ Hose down the interior of the tank with a "high-pressure" (~ 58...72.5 psi (~ 4...5 bar)) jet of cold water (→ Fig. 17).



You can increase the cleaning effect by heating up the heat exchanger in the drained tank before spraying out. The thermal shock effect releases scale deposits more easily from the coil-type heat exchanger.

- ▶ Use a wet/dry vacuum with a plastic suction pipe to remove any residues.

If extremely encrusted scale deposits have formed in the DHW tank:

- ▶ Hire someone to perform the chemical cleaning.



**WARNING:** Danger from improper use of the cleanser.

- ▶ Have a qualified contractor carry out the chemical cleaning operation.



**NOTICE:** The enamel layer may be damaged if the acid is too strong.

- ▶ Have a qualified contractor carry out the chemical cleaning operation.

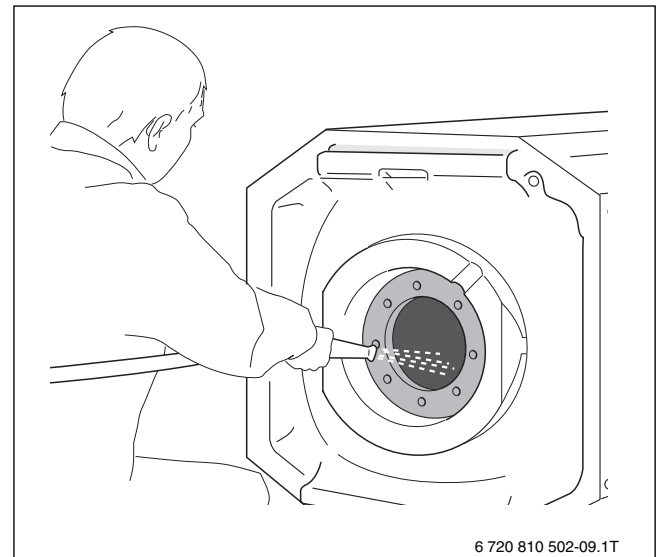

Fig. 17 Hosing down the interior of the DHW tank

### 9.3 Checking the magnesium anode

The magnesium anode is a sacrificial anode which is consumed during operation of the DHW tank.



If the magnesium anode is not serviced properly, the warranty is void.  
Annual service records must be kept in a safe location and submitted together with the original purchase receipt in the event of a warranty claim.

To determine whether the magnesium anode must be replaced:

- ▶ Check the magnesium anode annually.

The surface of the magnesium anode must be free of deposits. The magnesium anode must be replaced when:

- Deposits have formed
- The surface area has increased as the result of deposits
- Diameter is reduced to  $< 5/8"$  (15 mm)

Certain installations may require more frequent replacement of the magnesium anode rod:

- Recirculation connection
- Poor water quality
- Galvanic/electrolytic corrosion
- High flow rate

In the event of poor water quality it is recommended that a water treatment professional be consulted for water treatment options.



Never bring the magnesium anode surface in contact with oil or grease.

- ▶ Keep everything clean.

#### 9.3.1 Testing with the anode tester

We recommend that the protection current be measured annually with the aid of an anode tester. The anode tester is available as an accessory.



Follow the operating instructions for the anode tester.

Insulated installation of the magnesium anode is a prerequisite for use of an anode tester to measure the protection current (→ Fig. 18).

The protection current can be measured only with a water-filled storage tank.

- ▶ Ensure proper contact of the connecting terminals.
- ▶ Connect terminals to shiny metal surfaces only.
- ▶ Loosen the ground wire [6] (contact cable between the sacrificial anode and storage tank) at one of the two connection points.
- ▶ Attach red cable [1] to the sacrificial anode.
- ▶ Attach black cable [7] to the storage tank.
- ▶ If the ground wire has a plug: Attach red cable [1] to the threads of the magnesium anode [5]. Remove the ground wire [6] for the measurement.
- ▶ Replace magnesium anode if the anode current is  $< 0.3$  mA.
- ▶ After every test, it is essential that the ground wire [6] always be reattached properly.

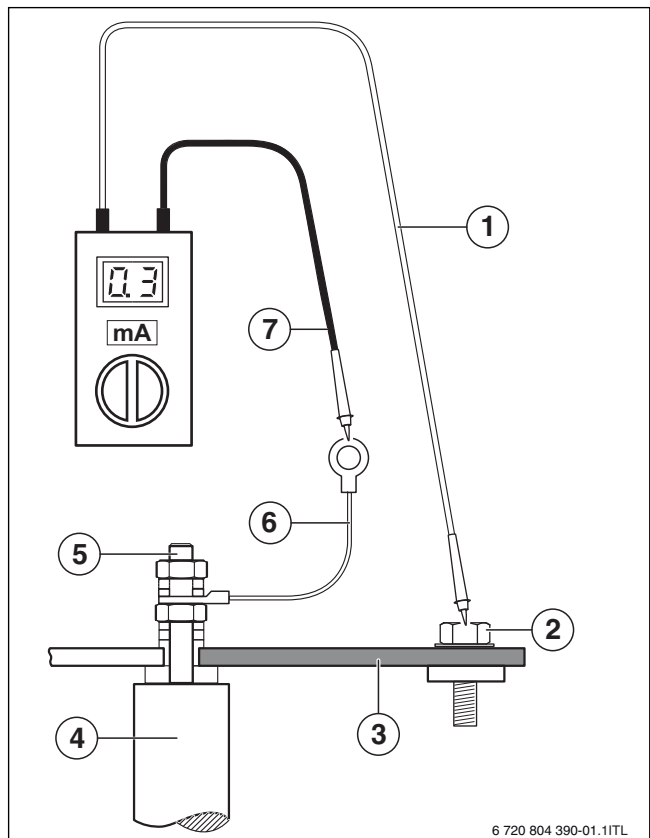

Fig. 18 Measuring the anode current

- [1] Red cable
- [2] Screw for ground wire
- [3] Handhole cover
- [4] Magnesium anode
- [5] Thread
- [6] Ground wire
- [7] Black cable

#### 9.3.2 Visual check



Never bring the magnesium anode surface into contact with oil or grease.

- ▶ Keep everything clean.

- ▶ Prepare the DHW tank for removal of the handhole cover (→ Chapter 9.1, page 15).
- ▶ Remove the handhole cover (→ Fig. 16, page 15).
- ▶ Check the magnesium anode.

If the diameter is reduced to  $< 5/8"$  (15 mm):

- ▶ Replace the magnesium anode.

#### 9.3.3 Replacing the magnesium anode

- ▶ Unscrew the M8 nut (→ Fig. 19 [1]) to release the eyelet of the ground wire [3].
- ▶ Unscrew the M8 nut [4].
- ▶ Remove the magnesium anode [10] from the handhole cover [8].
- ▶ Replace the magnesium anode.
- ▶ Fit the new magnesium anode together with all small parts supplied with it as shown in Fig. 19.



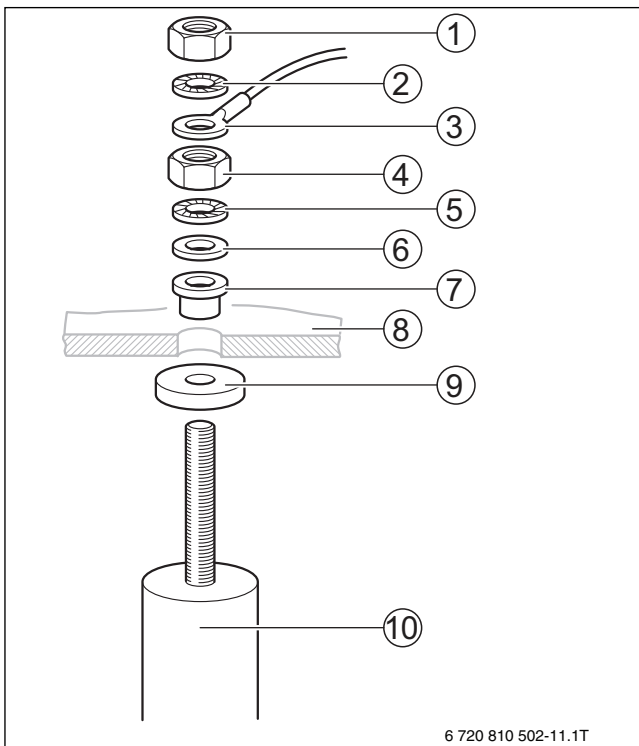

6 720 810 502-11.1T

Fig. 19 Replacing the magnesium anode

- [1] M8 Nut
- [2] Serrated washer
- [3] Eyelet on ground wire
- [4] M8 Nut
- [5] Serrated washer
- [6] Dished washer
- [7] Insulating sleeve
- [8] Handhole cover
- [9] Gasket
- [10] Magnesium anode

#### 9.4 Startup after maintenance



**NOTICE:** Risk of system damage from faulty gasket!  
To prevent leaks on the DHW tank:

- ▶ Use a new handhole cover gasket [4] after every maintenance.

- ▶ Refit handhole cover (→ Fig. 20 [3]) with a new handhole cover gasket [4].
- ▶ Attach the eyelet of the ground wire [2] with a hex hex bolt [1] and a serrated washer.



**NOTICE:** Risk of system damage from corrosion.  
To ensure that the magnesium anode functions properly:

- ▶ Fasten the eyelet of the ground wire to the handhole cover with a hex bolt to ensure good electrical conductivity.
- ▶ Thread hex bolts [1] into handhole cover [3] "hand-tight".
- ▶ Then use a torque wrench to tighten the hex bolts [1] to 18-22 ft lbs/ 25-30 Nm.
- ▶ Fill the DHW tank and restart the heating system.
- ▶ Check all connections and the handhole cover for leaks.

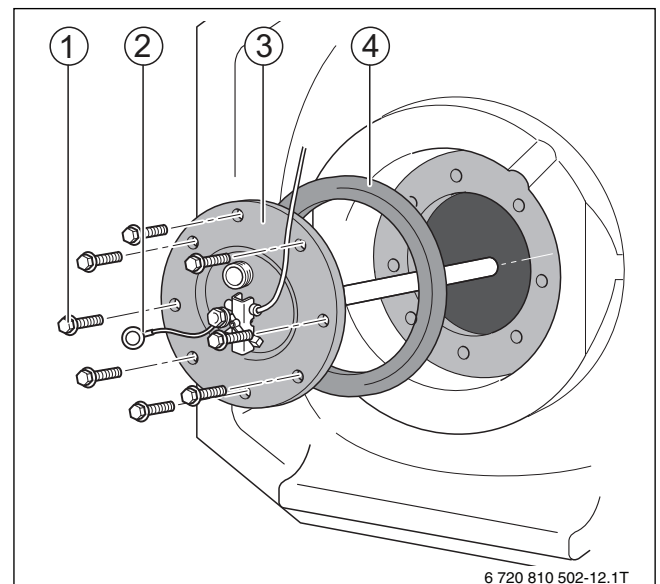

6 720 810 502-12.1T

Fig. 20 Reinstall handhole cover

- [1] Hex bolts
- [2] Eyelet on ground wire
- [3] Handhole cover
- [4] Handhole cover gasket

- ▶ Reinstall thermal insulation element and front cover of tank (→ Chapter 5.3.4, page 13).

10 Spare Parts

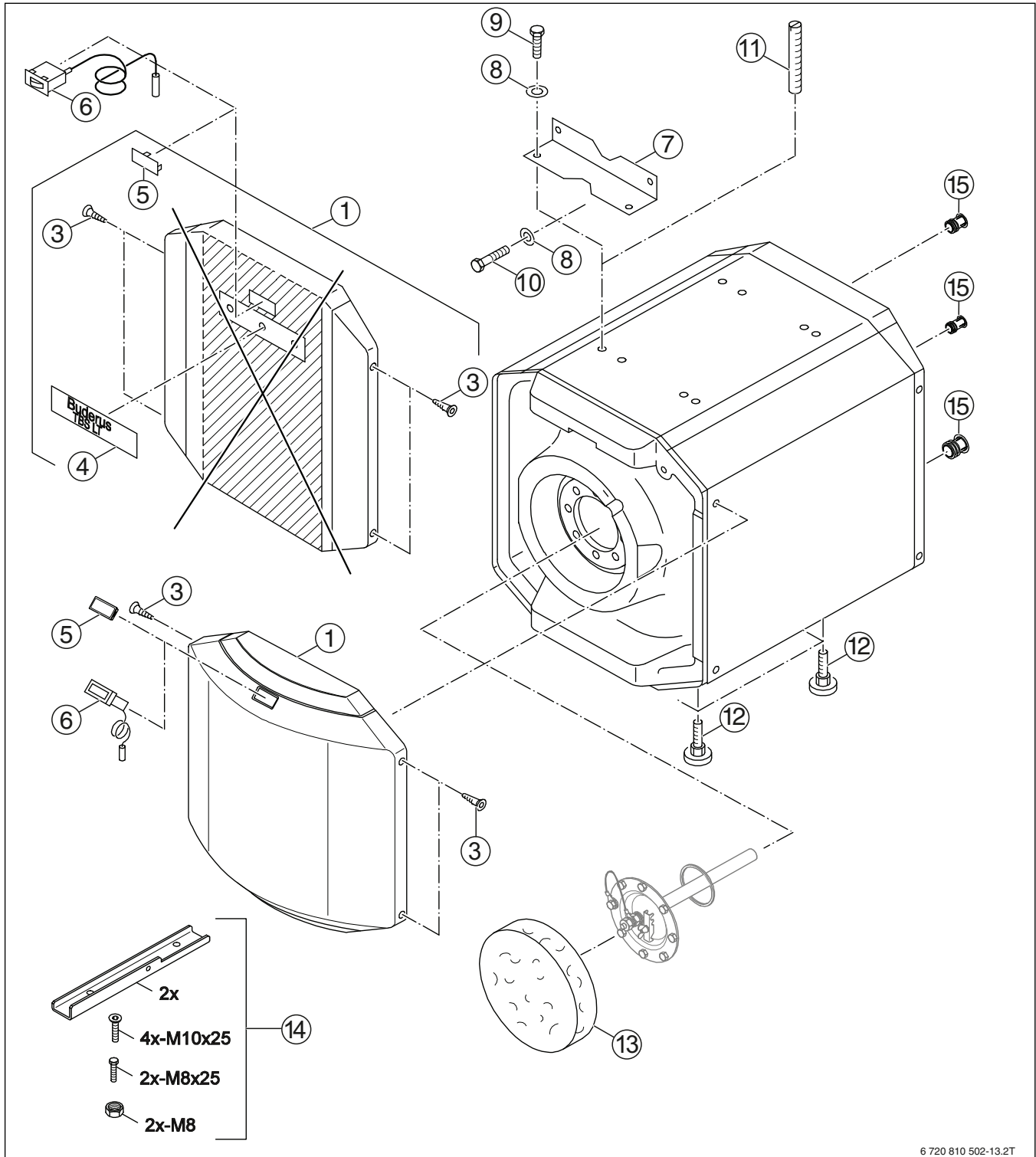

6 720 810 502-13.2T

Fig. 21 Spare parts for DHW tank Logalux LT160/1 - LT300/1 "US"

Item	Designation	Order no.	Comments
1	Front LT160 – LT300	5 236 320	No longer available
1	Front LT160/1 – LT300/1	63 029 650	
3	Sheet metal screw St 4.2x13 (10x)	7 747 027 696	
5	Blanking plate 28x61x6	3 869 300	
6	Thermometer 30...80 degrees C	5 236 200	
7	Angle bracket G115/S105	8 718 570 813 0	
8	Washer DIN125 10.5x2 (10x)	8 718 571 270 0	
9	Screw ISO4017 M10x30 A3K (10x)	7 747 022 050	
10	Hexagon screw ISO4014 M10x55 8.8 A3K	5 090 100	
11	Threaded stud ISO7434 M10x30 14H A3K	5 584 628	
12	Device feet M10x51 mm (Set of 4 pc.)	5 236 440	
13	Thermal insulation D260 inspection port	8 718 572 451 0	
14	Angle profile rails G215/LT160	5 261 230	Only for: LT160/1 NPT, LT160/1 NPT V1
14	Angle profile rails G215/LT200	5 261 232	Only for: LT200/1 NPT, LT200/1 NPT V1
14	Angle profile rails G215/LT300	5 261 234	Only for: LT300/1 NPT, LT300/1 NPT V1
15	Sleeve R3/4x35	63 017 919	
15	Sleeve R1x35	63 017 920	
15	Sleeve R1 1/4x35	63 017 921	

Table 7 Spare parts for DHW tank Logalux LT160/1 – LT300/1 "US"

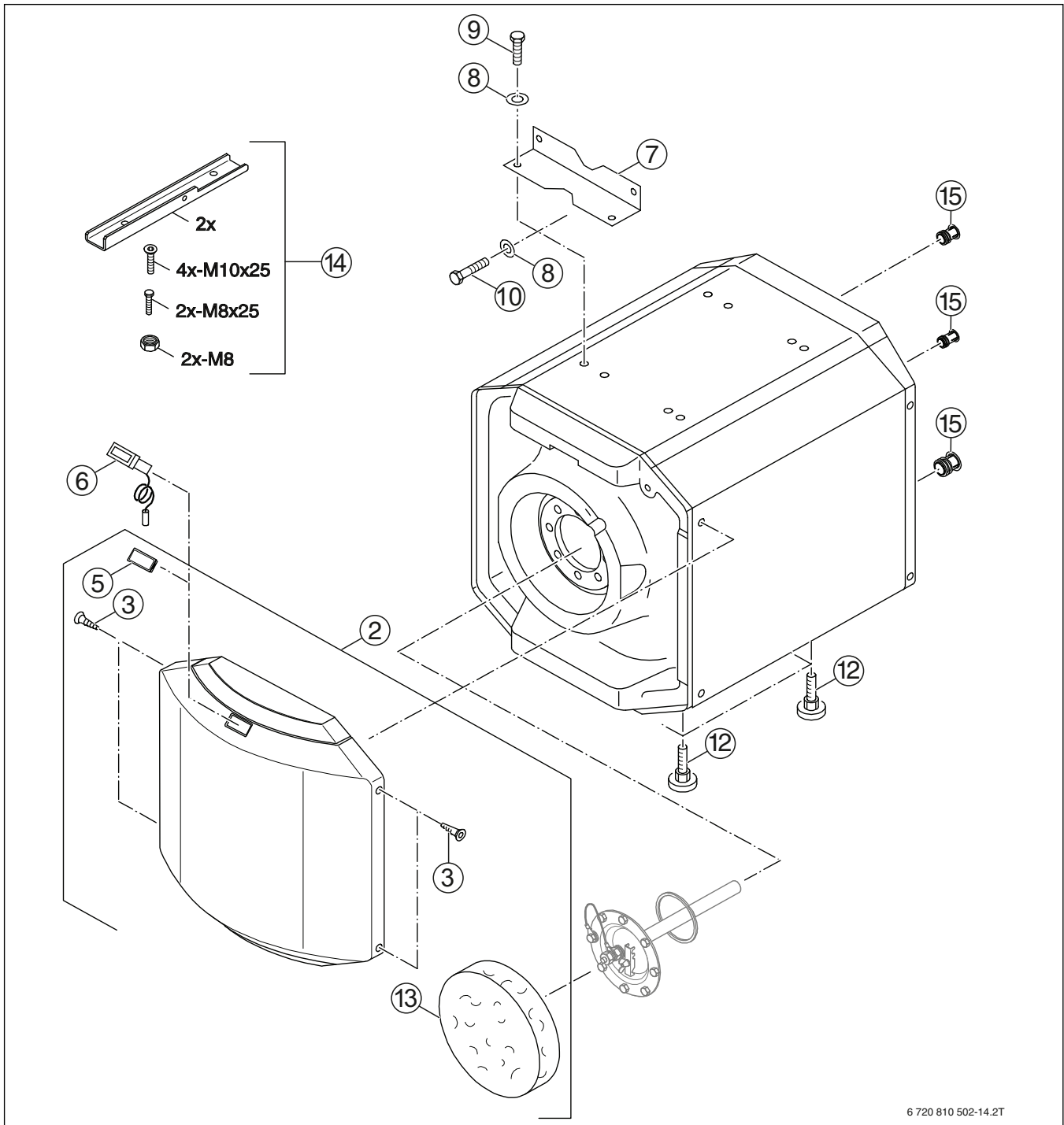

6 720 810 502-14.2T

Fig. 22 Spare parts for DHW tank Logalux LT160/1 - LT300/1 "US"

Item	Designation	Order no.	Comments
2	Front LT160/1 – LT300/1	63 029 650	
3	Sheet metal screw St 4.2x13 (10x)	7 747 027 696	
5	Blanking plate 28x61x6	3 869 300	
6	Thermometer 30...80 degrees C	5 236 200	
7	Angle bracket G115/S105	8 718 570 813 0	
8	Washer DIN125 10.5x2 (10x)	8 718 571 270 0	
9	Screw ISO4017 M10x30 A3K (10x)	7 747 022 050	
10	Hexagon screw ISO4014 M10x55 8.8 A3K	5 090 100	
12	Device feet M10x51 mm (Set of 4 pc.)	5 236 440	
13	Thermal insulation D260 inspection port	8 718 572 451 0	
14	Angle profile rails G215/LT160	5 261 230	Only for: LT160/1 NPT V2
14	Angle profile rails G215/LT200	5 261 232	Only for: LT200/1NPT V2
14	Angle profile rails G215/LT300	5 261 234	Only for: LT300/1 NPT V2
15	Sleeve R3/4x35	63 017 919	
15	Sleeve R1x35	63 017 920	
15	Sleeve R1 1/4x35	63 017 921	

Table 8 Spare parts for DHW tank Logalux LT160/1 – LT300/1 "US"

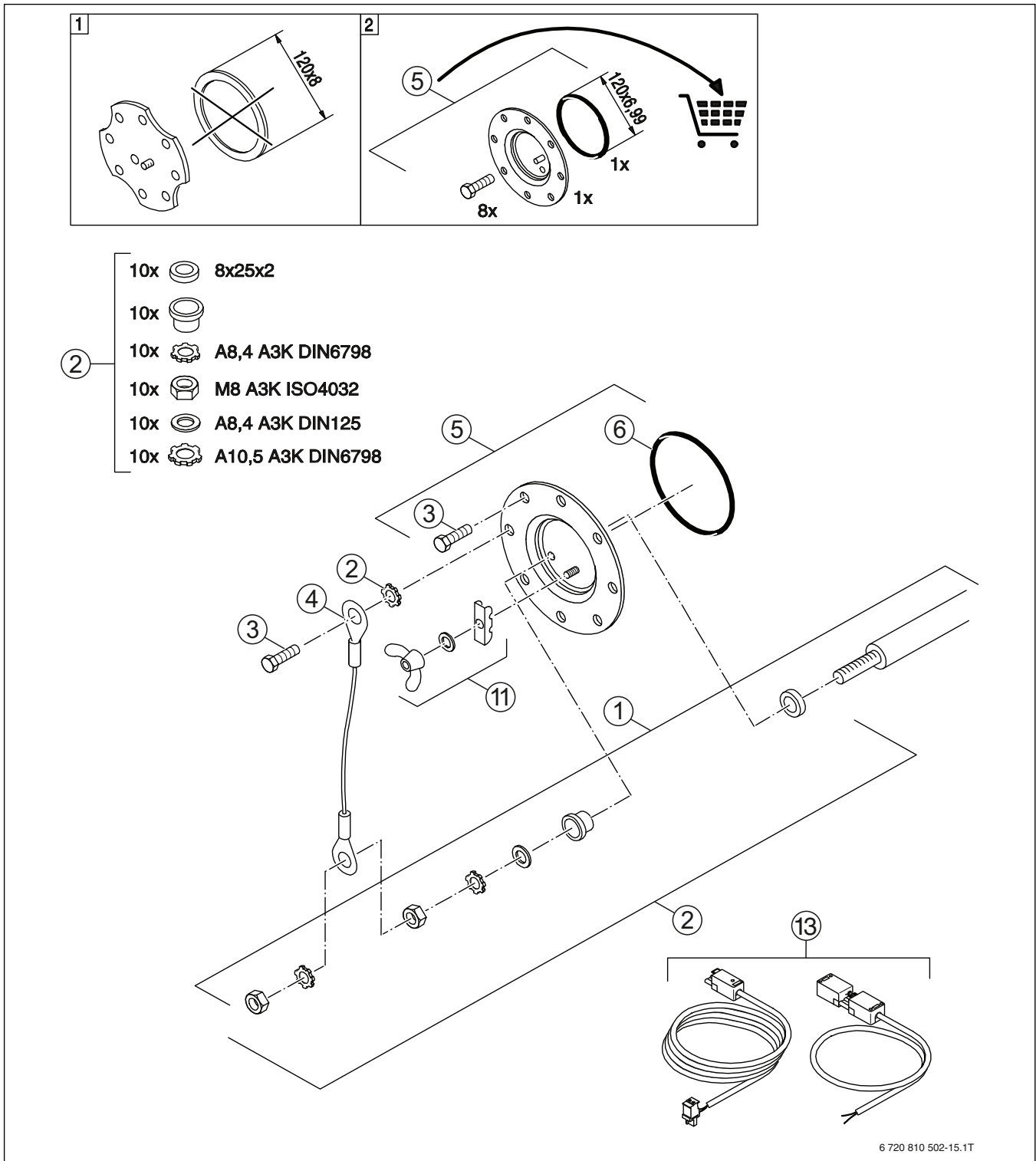

Fig. 23 Spare parts for DHW tank Logalux LT160/1 - LT300/1 "US"

Item	Designation	Order no.	Comments
1	Sacrificial anode D33x400 mm	8 718 571 568 0	Only for: LT160/1 NPT, LT160/1 NPT V1, LT160/1 NPT V2
1	Sacrificial anode D33x500 mm	8 718 571 569 0	Only for: LT200/1 NPT, LT200/1 NPT V1, LT200/1 NPT V2
1	Sacrificial anode D33x700 mm	8 718 571 570 0	Only for: LT300/1 NPT, LT300/1 NPT V1, LT300/1 NPT V2
2	Mounting kit, magn. anodes insulated 10 pc.	5 264 278	
3	Thread-forming screws M10x25 set (8x)	7 747 005 744	
4	Ground wire insulated for sacrificial anode	63 037 168	
5	Manhole cover D210 mm and stud bolt	63 014 370	Only for: LT160/1 NPT, LT160/1 NPT V1 (<06/2007) LT200/1 NPT, LT200/1 NPT V1 (<06/2007) LT300/1 NPT, LT300/1 NPT V1 (<06/2007)
5	Manhole cover DN120 LT/L	7 747 004 730	Only for: LT160/1 NPT V2 (>07/2007) LT160/1 NPT V2 (>07/2007) LT160/1 NPT V2 (>07/2007)
6	Sealing ring 120x152x10 mm	63 043 454	Only for: LT160/1 NPT, LT160/1 NPT V1 (<06/2007) LT200/1 NPT, LT200/1 NPT V1 (<06/2007) LT300/1 NPT, LT300/1 NPT V1 (<06/2007)
6	O-ring 120.02x6.99-N	8 718 572 538 0	Only for: LT160/1 NPT V2 (>07/2007) LT160/1 NPT V2 (>07/2007) LT160/1 NPT V2 (>07/2007)
11	Support contact sensor	63 038 417	
13	Sensor extension cable kit for LT300	5 118 760	Only for: LT300/1 NPT, LT300/1 NPT V1, LT300/1 NPT V2

Table 9 Spare parts for DHW tank Logalux LT160/1 – LT300/1 "US"

**United States and Canada**

Bosch Thermotechnology Corp.  
50 Wentworth Avenue  
Londonderry, NH 03053  
Tel. 603-552-1100  
Fax 603-965-7581  
[www.buderus.us](http://www.buderus.us)  
U.S.A.

Products manufactured by  
Bosch Thermotechnik GmbH  
Sophienstrasse 30-32  
D-35576 Wetzlar  
[www.bosch-thermotechnology.com](http://www.bosch-thermotechnology.com)

Bosch Thermotechnology Corp. reserves the right  
to make changes without notice due to continuing  
engineering and technological advances.

**Buderus**