

Job Name: _____

System Reference: _____ Date: _____



Indoor Unit: MSZ-GL24NA-U1



Wireless Remote Controller



Outdoor Unit: MUZ-GL24NA-U1

ACCESSORIES:

Indoor Unit

- Condensate Pump (BlueDiamond X87-711/721; 115/230V)
- Condensate Pump (Sauermann SI30-115/230; 115/230V)
- Anti-Allergy Enzyme Filter (MAC-408FT-E)
- Drain Pan Level Sensor (DPLS2)

Outdoor Unit

- Outdoor Mounting Pad (ULTRILITE1)
- Drain Pan Heater (MAC-642BH-U)
- 3-1/4" Mounting Base [Pair] (DSD-400P)
- Drain Pan Socket (MAC-851DS)
- Air Outlet Guide (MAC-886SG-E)
- Wall Mounting Bracket (QSWB2000M-1)

Controls

- Wireless Controller (MHK1)
- Wired Remote Controller PAR-32MAA (Requires MAC-333IF-E)
- Wireless Interface for kumo cloud™ (PAC-USWHS002-WF-1)
- Thermostat Interface (PAC-US444CN-1)

SPECIFICATIONS:

Rated Conditions (Capacity / Input)

Cooling ¹	Btu/h / W	22,400 / 1,800
Heating at 47° F ²	Btu/h / W	27,600 / 2,340

Capacity Range		Minimum	Maximum
Cooling ¹	Btu/h	8,200	31,400
Heating at 47° F ²	Btu/h	7,500	36,900
Heating at 17° F ³	Btu/h	-	24,600
Heating at 5° F ⁴	Btu/h	-	21,160

¹ Cooling | Indoor: 80° F (27° C) DB / 67° F (19° C) WB; Outdoor: 95° F (35° C) DB / 75° F (24° C) WB
² Heating at 47° F | Indoor: 70° F (21° C) DB / 60° F (16° C) WB; Outdoor: 47° F (8° C) DB / 43° F (6° C) WB
³ Heating at 17° F | Indoor: 70° F (21° C) DB / 60° F (16° C) WB; Outdoor: 17° F (-8° C) DB / 15° F (-9° C) WB
⁴ Heating at 5° F | Indoor: 70° F (21° C) DB / 60° F (16° C) WB; Outdoor: 5° F (-15° C) DB / 5° F (-15° C) WB
 * Rating Conditions per AHRI Standard:

Operating Conditions (Indoor Intake Air Temp.) (Max./ Min.)

Cooling ²	90° F (32° C) DB / 67° F (19° C) DB
Heating	80° F (27° C) DB / 70° F (21° C) DB

Operating Conditions (Outdoor Intake Air Temp.) (Max./ Min.)

Cooling ⁵	115 F (46° C) DB / 14° F (-10° C) DB
Heating	75° F (24° C) DB / -4° F (-20° C) DB**

⁵ Applications should be restricted to comfort cooling only; equipment cooling applications are not recommended for low ambient temperature conditions.
 ** System cuts out at -9° F (-27° C) to avoid thermistor error and automatically restarts at -4° F (-20° C).

AHRI Efficiency Ratings

SEER / HSPF	20.5 / 10.0
COP at 47° F / 17° F	3.46 / 2.65

Energy Star® Yes

ENERGY STAR products are third-party certified by an EPA-recognized Certification Body.

Specifications are subject to change without notice.

Electrical Power Requirements	208 / 230V, 1-Phase, 60 Hz
--------------------------------------	----------------------------

Minimum Circuit Ampacity (MCA)		
Indoor / Outdoor	A	1 / 17.1

Indoor Unit		
Blower Motor (ECM)	F.L.A.	0.76
Blower Motor Output	W	55
SHF / Moisture Removal		0.75 / 5.1 pt./h
Field Drainpipe Size O.D.	In.(mm)	5/8 (15)

Outdoor Unit		
Compressor		DC INVERTER-driven Twin Rotary
Fan Motor (ECM)	F.L.A.	0.93

Airflow Rate (Quiet - Lo - Med - Hi - Super Hi)			
Indoor (Cooling)	DRY	CFM	388-469-544-628-738
	WET		347-420-487-562-661
Indoor (Heating)	DRY		388-469-544-628-738
			1769 / 1701
Outdoor			

Sound Pressure Level (Quiet - Lo - Med - Hi - Super Hi)			
Indoor	Cooling	dB(A)	34-41-45-49-53
	Heating		32-41-45-49-52
Outdoor	Cooling		55
	Heating		55

External Dimensions		
Indoor (H x W x D)	In.(mm)	12-13/16 x 43-5/16 x 9-3/8 (325 x 1,100 x 238)
Outdoor (H x W x D)		34-5/8 x 33-1/16 x 13 (880 x 840 x 330)

Net Weight		
Indoor	Lbs.(kg)	37 (17)
Outdoor		119 (54)

External Finish	
Indoor	Munsell 1.0Y 9.2 / 0.2
Outdoor	Munsell No. 3Y 7.8 / 1.1

Refrigerant	R410A; 4 lb. 3 oz.
--------------------	--------------------

Refrigerant Piping (Flared)		
Liquid (High Pressure)	In.(mm)	3/8 (9.52)
Gas (Low Pressure)		5/8 (15.88)
Max. Total Refrigerant Pipe Length (Height Diff.)	Ft. (m)	50 (15)
Max. Total Refrigerant Pipe Length (Length.)		100 (30)

DIMENSIONS: MSZ-GL24NA-U1 & MUZ-GL24NA-U1

MSZ-GL24NA-U1

Unit: in. (mm)

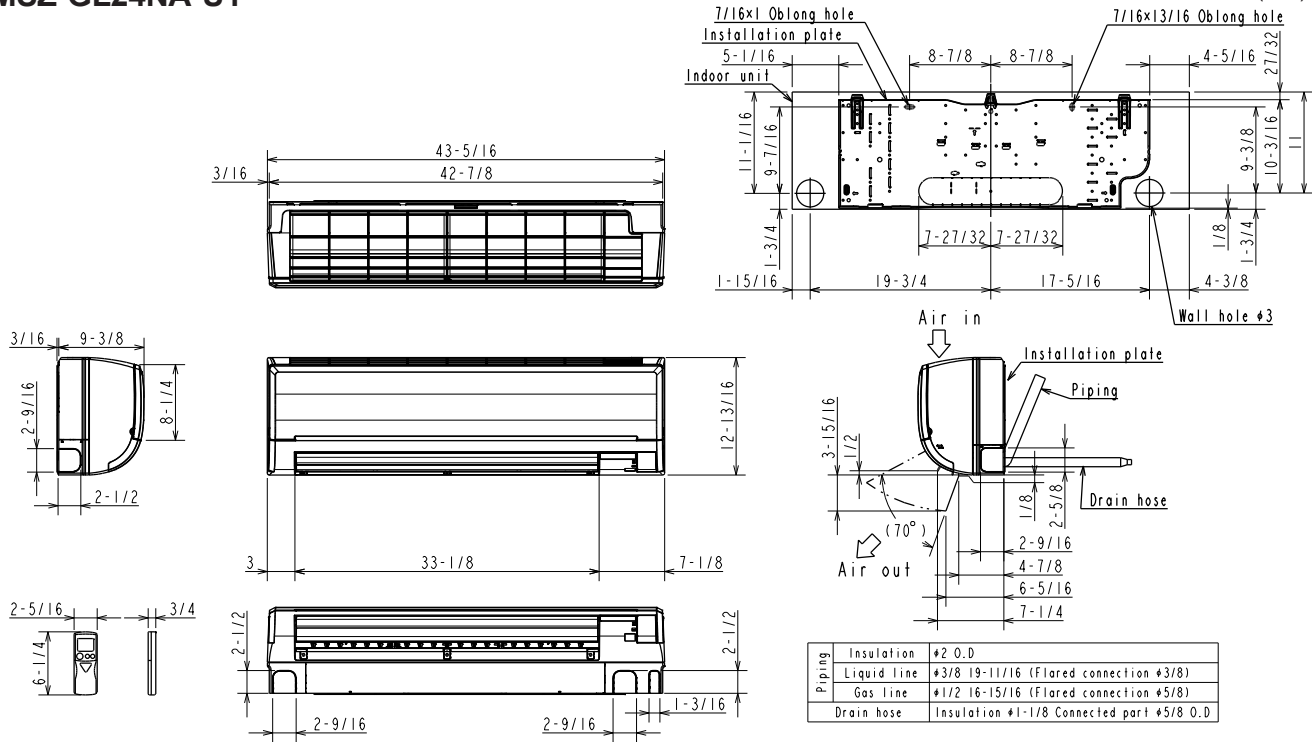

MUZ-GL24NA-U1

REQUIRED SPACE

Unit: in. (mm)

*1 20 in. (500 mm) or more when front and sides of the unit are clear

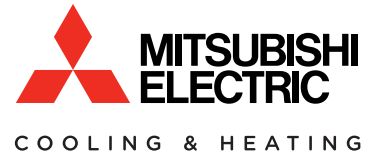
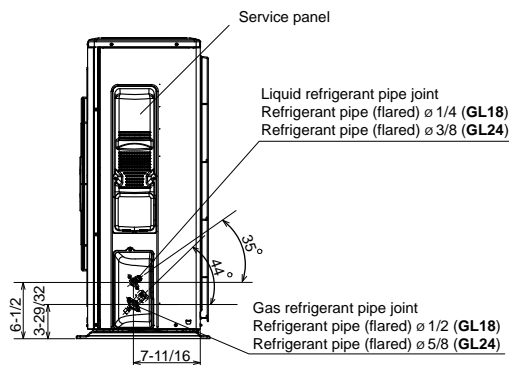
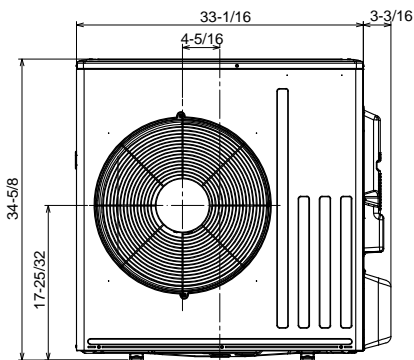
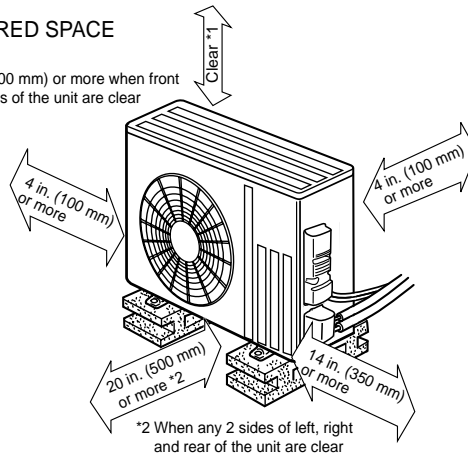
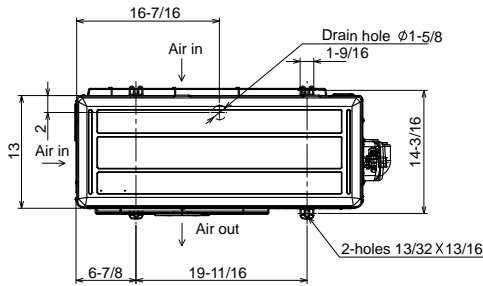

1340 Satellite Boulevard, Suwanee, GA 30024
Toll Free: 800-433-4822 www.mehvac.com

