

R-410A & R-22 SPLIT SYSTEM AC & HP

APPLICATION GUIDELINE AND SERVICE MANUAL

TABLE OF CONTENTS

UNIT IDENTIFICATION	3	Coil Removal	27
SAFETY CONSIDERATIONS	6	Aluminum Coil Removal	27
INTRODUCTION	6	Compressor Removal and Replacement	28
INSTALLATION GUIDELINE	6	System Clean-Up After Burnout	29
Residential New Construction	6	Evacuation	29
Add-On Replacement (Retrofit) - R-22 to R-410A	6	Troubleshooting with SuperHeat	30
Seacoast	6	Two Stage	
LOW-AMBIENT COOLING GUIDELINE	6	Non-communicating N4A7/N4H6	40
LONG LINE GUIDELINE	6	Operating Ambient	40
ACCESSORY DESCRIPTIONS	6	Airflow Selections (ECM Furnaces)	40
CABINET ASSEMBLY	7	Airflow Selection for Variable Speed Furnaces (non-communicating)	40
Labeling	8	Airflow Selection for FVM4X Fan Coils	
ELECTRICAL	9	(non-communicating)	40
Aluminum Wire	9	System function and Sequence	
Contactor	9	Of Operation (N4A7/N4H6)	40
Capacitor	9	Cooling	40
Cycle Protector	10	Heating	40
Crankcase Heater	10	Compressor Operation	40
Time-Delay Relay (TDR)	10	Quiet Shift	41
Pressure Switches	11	Quiet Shift-2 (non-communicating)	41
Defrost Thermostat	11	Defrost	41
Defrost Control Boards	12	Defrost Speedup	41
FAST # 1173636 / 1177927 / 1190281 DEFROST CONTROL	12	CHECK CHARGE	41
DEFROST CONTROL (Fast # 1174185)	14	Single-stage AC (*SA5, *SA6)	
System Function and Sequence of Operation (Fast # 1174185)	14	GENERAL SEQUENCE OF OPERATION - standard thermostat	42
Troubleshooting (Fast # 1174185)	15	AC control FUNCTIONS	
FAST# 1185790 DEFROST CONTROL	15	AND SEQUENCE OF OPERATION	42
Quiet Shift-2 (non-communicating)	15	SEQUENCE OF OPERATION	42
ECM Fan Motor (single stage equipment)	15	SINGLE-STAGE HEAT PUMP	
PSC Fan Motor	16	(*SH4, *SH5, *SH6)	
Compressor Plug	16	GENERAL SEQUENCE OF OPERATION - STANDARD THERMO-	
Low-Voltage Terminals	16	STAT	42
COPELAND SCROLL COMPRESSOR	16	HEAT PUMP SYSTEM FUNCTIONS	
LG SCROLL COMPRESSOR	17	AND SEQUENCE OF OPERATION	43
Characteristics of the LG Scroll Compressor	17	SEQUENCE OF OPERATION	43
COMPRESSOR TROUBLESHOOTING	18	DEFROST	43
Compressor Failures	18	DEFROST HOLD	44
Mechanical Failures	18	FORCED DEFROST	44
Electrical Failures	19	QUIET SHIFT-2	44
REFRIGERATION SYSTEM	20	LIQUID LINE SOLENOID ACCESSORY	44
Refrigerant	20	MAJOR COMPONENTS	45
Servicing Systems on Roofs With Synthetic Materials	20	TROUBLESHOOTING (Single-stage)	45
Brazing	21	TWO-STAGE *CA7, *CA9, *CH6, *CH9	51
Aluminum Brazing	21	Application Guidelines	51
Service Valves and Pumpdown	21	Model Plug	51
Liquid Line Filter Drier	23	Airflow Selections for *CA7, *CA9, *CH6, *CH9 Using Non-Com-	
Suction Line Filter Drier	24	municating Thermostats	51
Accumulator	24	GENERAL INFORMATION	51
Thermostatic Expansion Valve (TXV)	24	Defrost	51
Make Piping Connections	26	Quiet Shift-2 (Communicating models)	
REFRIGERATION SYSTEM REPAIR	27	(FAST # 1185237, 1186140)	52
Leak Detection	27		

Liquid-Line Solenoid Accessory 52

Check Charge 53

 Heating Check Chart Procedure 53

System Functions and Sequence of Operation

(*CA7, *CA9, *CH6, *CH9) 53

 Cooling and Heating Operation 53

 Communication and Status Function Lights For Communicating Control only, Green communications (COMM) Light 53

 Compressor Operation 53

 Fan Motor 54

 Time Delays 55

 Pressure Switches 55

 Muffler, Accumulator, Reversing Valve (RVS) 55

 Thermistors 55

 Control Box 56

TROUBLESHOOTING 57

 Troubleshooting circuit board FAST # 1185237, 1186140 57

 Systems Communication Failure 57

 Pressure Switch Protection 57

 Control Fault 57

 Brown-Out Protection 57

 230v Brown-Out Protection Defeated 57

 230V Line (Power Disconnect) Detection 57

 Compressor Voltage Sensing 57

 Contactor Shorted Detection 57

 Compressor Thermal Cutout - *CA7, *CA9, *CH6, *CH9 57

 Low or High Contactor Open / No 230V at Compressor Contactor - *CA7, *CA9, *CH6, *CH9 57

 Troubleshooting units for proper switching between low & high stages - *CA7, *CA9, *CH6, *CH9 58

 Unloader Test Procedure - *CA7, *CA9, *CH6, *CH9 58

 Temperature Thermistors 58

 Thermistor Sensor Comparison 58

 Failed Thermistor Default Operation 58

CARE AND MAINTENANCE 60

 Desert and Seacoast Locations 60

 Cleaning Coil 60

 Cleaning Outdoor Fan Motor and Blade 60

 Electrical Controls and Wiring 60

 Refrigerant Circuit 60

 Final Check-Out 61

INDEX OF TABLES 64

UNIT IDENTIFICATION

Troubleshooting Charts for Air Conditioners and Heat Pumps are provided in the appendix at back of this manual. They enable the service technician to use a systematic approach to locate the cause of a problem and correct system malfunctions. This section explains how to obtain the

model and serial number from the unit rating plate. These numbers are needed to service and repair the R-410A and R-22 air conditioner or heat pump. Model and serial numbers can be found on unit rating plate.

Table 1 – Air Conditioner and Heat Pump Model Number Nomenclature

OUTDOOR UNIT MODEL NUMBER IDENTIFICATION GUIDE											
Digit Position:	1	2	3	4	5, 6	7	8	9	10	11	12
Example Part Number:	N	4	A	3	18	L	K	A	1	0	1
BRANDING * = Mainline N = Entry											
REFRIGERANT 4 = R-410A X = R-410A											
TYPE A = Air Conditioner H = Heat Pump											
NOMINAL EFFICIENCY 3 = 13 SEER 4 = 14 SEER 5 = 15 SEER 6 = 16 SEER 7 = 17 SEER											
NOMINAL CAPACITY 18 = 18,000 BTUH = 1-1/2 tons 24 = 24,000 BTUH = 2 tons 30 = 30,000 BTUH = 2-1/2 tons 36 = 36,000 BTUH = 3 tons 42 = 42,000 BTUH = 3-1/2 tons 48 = 48,000 BTUH = 4 tons 60 = 60,000 BTUH = 5 tons											
FEATURES A = Standard Grille C = Coastal G = Coil Guard Grille L = Aluminum Coil											
VOLTAGE H = 208/230-3-60 K = 208-230-1-60 L = 460-3-60											
Sales Code											
Engineering Revision											
Extra Digit											
Extra Digit											

OUTDOOR UNIT MODEL NUMBER IDENTIFICATION GUIDE (single phase)											
Digit Position:	1	2	3	4	5, 6	7	8	9	10	11	12
Example Part Number:	*	C	A	9	24	G	K	A	2	0	0
BRANDING * = Mainline											
KEY CHARACTERISTIC C = Two stage communicating S = Single stage communicating											
TYPE A = Air Conditioner H = Heat Pump											
NOMINAL EFFICIENCY 5 = 15 SEER 6 = 16 SEER 7 = 17 SEER 8 = 18 SEER 9 = 19 SEER											
NOMINAL CAPACITY 24 = 24,000 BTUH = 2 tons 36 = 36,000 BTUH = 3 tons 48 = 48,000 BTUH = 4 tons 60 = 60,000 BTUH = 5 tons											
FEATURES G = Coil Guard Grille											
VOLTAGE K = 208-230-1-60											
Sales Code											
Engineering Revision											
Extra Digit											
Extra Digit											

OUTDOOR UNIT MODEL NUMBER IDENTIFICATION GUIDE (single phase)									
Digit Position:	1,2	3	4	5,6	7	8	9	10	11
Example Part Number:	WC	A	5	24	4	G	K	A	1
WC = Condensing Unit									
TYPE									
A = Air Conditioner H = Heat Pump									
SEER									
3 = 13 SEER 4 = 14 SEER 5 = 15 SEER									
NOMINAL CAPACITY									
18 = 18,000 BTUH = 1½ tons 24 = 24,000 BTUH = 2 tons 30 = 30,000 BTUH = 2½ tons 36 = 36,000 BTUH = 3 tons 42 = 42,000 BTUH = 3½ tons 48 = 48,000 BTUH = 4 tons 60 = 60,000 BTUH = 5 tons									
REFRIGERANT									
4 = R-410A									
FEATURE									
A = Standard Grille G = Coil Guard Grille									
VOLTAGE									
K = 208-230-1-60									
Sales Code									
Extra Digit									

SAFETY CONSIDERATIONS

Installation, service, and repair of these units should be attempted only by trained service technicians familiar with standard service instruction and training material.

All equipment should be installed in accordance with accepted practices and unit Installation Instructions, and in compliance with all national and local codes. Power should be turned off when servicing or repairing electrical components. Extreme caution should be observed when troubleshooting electrical components with power on. Observe all warning notices posted on equipment and in instructions or manuals.

WARNING

UNIT OPERATION AND SAFETY HAZARD

Failure to follow this warning could result in personal injury or equipment damage.

R-410A systems operate at higher pressures than standard R-22 systems. Do not use R-22 service equipment or components on R-410A equipment. Ensure service equipment is rated for R-410A.

Refrigeration systems contain refrigerant under pressure. Extreme caution should be observed when handling refrigerants. Wear safety glasses and gloves to prevent personal injury. During normal system operations, some components are hot and can cause burns. Rotating fan blades can cause personal injury. Appropriate safety considerations are posted throughout this manual where potentially dangerous techniques are addressed.

INTRODUCTION

This document provides required system information necessary to install, service, repair or maintain the family air conditioners and heat pumps using R-22 or R-410A refrigerant.

Refer to the unit specifications and technical support manuals for rating information, electrical data, required clearances, additional component part numbers and related pre-sale data. Installation Instructions are also available per specific models.

INSTALLATION GUIDELINE

Residential New Construction

Specifications for these units in the residential new construction market require the outdoor unit, indoor unit, refrigerant tubing sets, metering device, and filter drier listed in specification sheets and technical support manuals. DO NOT DEVIATE. Consult unit Installation Instructions for detailed information.

Add-On Replacement (Retrofit) - R-22 to R-410A

Specifications for these units in the add-on replacement/retrofit market require change-out of outdoor unit, metering device, and all capillary tube coils. Change-out of indoor coil is recommended. There can be no deviation.

1. If system is being replaced due to compressor electrical failure, assume acid is in system. If system is being replaced for any other reason, use approved acid test kit to determine acid level. If even low levels of acid are detected install factory approved, 100 percent activated alumina suction-line filter drier in addition to the factory supplied liquid-line filter drier. Remove the suction line filter drier as soon as possible, with a maximum of 72 hr.
2. Drain oil from low points or traps in suction-line and evaporator if they were not replaced.
3. Change out indoor coil or verify existing coil is listed in the specifications or AHRIdirectory.org.
4. Unless indoor unit is equipped with a R-410A approved metering device, change out metering device to factory supplied or field-accessory device specifically designed for R-410A.

5. Replace outdoor unit with R-410A outdoor unit.
6. Install factory-supplied liquid-line filter drier.

CAUTION

UNIT DAMAGE HAZARD

Failure to follow this caution may result in equipment damage or improper operation.

Never install suction-line filter drier in the liquid-line of an R-410A system.

7. If suction-line filter drier was installed for system clean up, operate system for 10 hr. Monitor pressure drop across drier. If pressure drop exceeds 3 psig, replace suction-line and liquid-line filter driers. Be sure to purge system with dry nitrogen and evacuate when replacing filter driers. Continue to monitor pressure drop across suction-line filter drier. After 10 hr of runtime, remove suction-line filter drier and replace liquid-line filter drier. Never leave suction-line filter drier in system longer than 72 hr (actual time).
8. Charge system. (See unit information plate.)

Seacoast

Coastal units are available in selected models and sizes of Air Conditioners and Heat Pumps. These units have protection to help resist the corrosive coastal environment. Features include:

- Epoxy coated coils
- Complete baked-on paint coverage (both sides of external sheet metal and grilles)
- Paint coated screws

Coastal environments are considered to be within 2 miles of the ocean. Salt water can be carried as far away as 2 miles from the coast by means of sea spray, mist or fog.

Line-of-sight distance from the ocean, prevailing wind direction, relative humidity, wet/dry time, and coil temperatures will determine the severity of corrosion potential in the coastal environment.

LOW-AMBIENT COOLING GUIDELINE

The minimum operating temperature for these units in cooling mode is 55°F/12.7°C outdoor ambient without additional accessories. Low ambient cannot be used with Communicating control. If Low ambient requirements are needed, use as non-communicating, and refer to specification sheets for proper accessories required. Wind baffles are required when operating in cooling mode at ambients below 55°F/12.7°C. Plans are shown in Low Ambient Pressure Kit instructions.

LONG LINE GUIDELINE

Refer to Split System Long Line Applications Guidelines for air conditioner and heat pump systems.

ACCESSORY DESCRIPTIONS

See the appropriate specification sheets and installation manuals for accessory information.

CABINET ASSEMBLY

Access Compressor Or Other Internal Cabinet Components

NOTE: It is not necessary to remove the top cover to gain access. Removing the top cover may cause grill panels, corner posts or coils to be damaged. It is recommended to protect the top cover from damage of tools, belt buckles, etc. while servicing from the top.

1. Should the unit height allow components to be accessed from the top of the unit, follow procedures for removing fan motor assembly. Access components through the top cap.
2. Large components may not be removed easily without having access from the top and side. Side access may allow procedures

such as brazing, cutting, and removal easier. Follow procedures below:

- a. Follow procedures to remove the fan motor assembly.
- b. Air conditioning units only, remove the screws from the top of the electrical control panel. (Heat pumps will not have screws holding the electrical control panel in place at the top once the control box cover has been removed.)
- c. Remove the base pan screws holding the control panel and lift off the unit.

Certain maintenance routines and repairs require removal of cabinet panels.

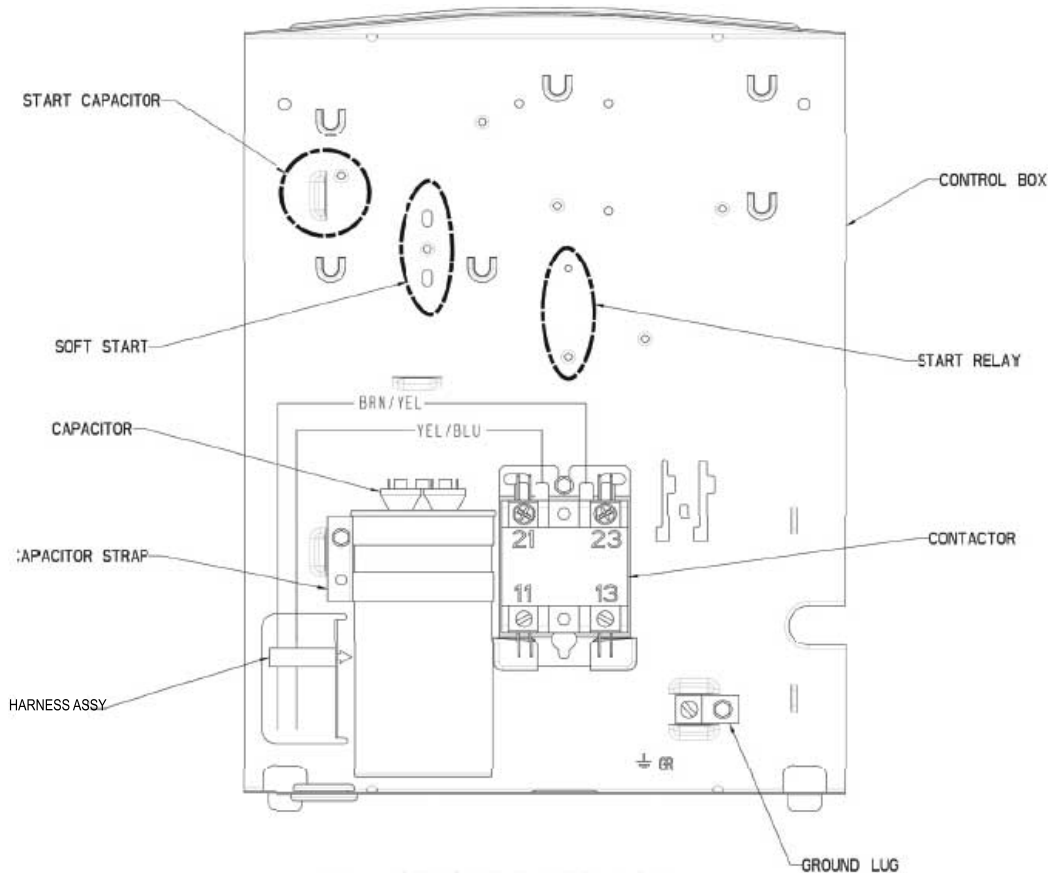

Fig. 1 – Typical AC Control Box

A210700

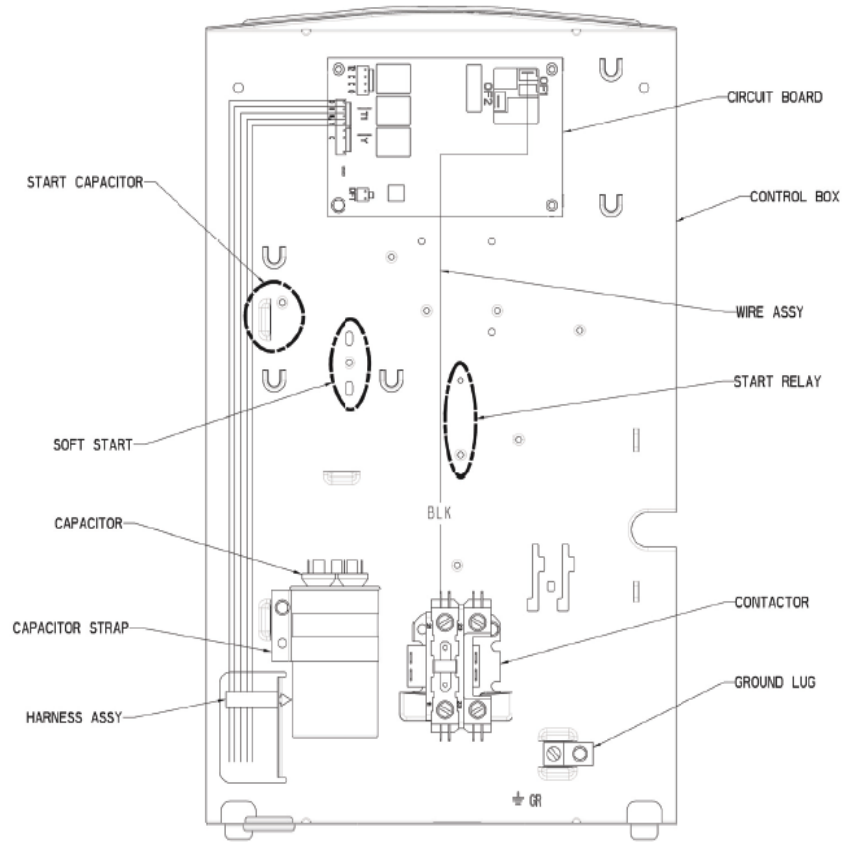

Fig. 2 – Typical HP Control Box

A210701

Labeling

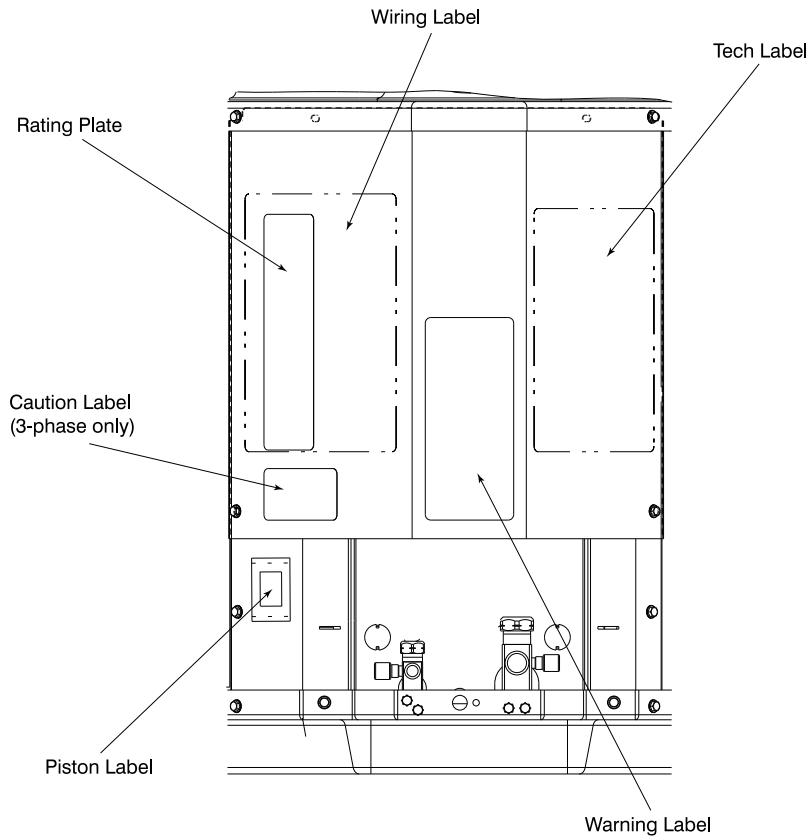

Fig. 3 – Typical Labeling

A150066

ELECTRICAL

WARNING

ELECTRICAL SHOCK HAZARD

Failure to follow this warning could result in personal injury or death. Exercise extreme caution when working on any electrical components. Shut off all power to system prior to troubleshooting. Some troubleshooting techniques require power to remain on. In these instances, exercise extreme caution to avoid danger of electrical shock. **ONLY TRAINED SERVICE PERSONNEL SHOULD PERFORM ELECTRICAL TROUBLESHOOTING.**

Aluminum Wire

CAUTION

UNIT OPERATION AND SAFETY HAZARD

Failure to follow this caution may result in equipment damage or improper operation.

Aluminum wire may be used in the branch circuit (such as the circuit between the main and unit disconnect), but only copper wire may be used between the unit disconnect and the unit.

Whenever aluminum wire is used in branch circuit wiring with this unit, adhere to the following recommendations.

Connections must be made in accordance with the National Electrical Code (NEC), using connectors approved for aluminum wire. The connectors must be UL approved (marked Al/Cu with the UL symbol) for the application and wire size. The wire size selected must have a current capacity not less than that of the copper wire specified, and must not create a voltage drop between service panel and unit in excess of 2 of unit rated voltage. To prepare wire before installing connector, all aluminum wire must be “brush-scratched” and coated with a corrosion inhibitor such as Pentrox A. When it is suspected that connection will be exposed to moisture, it is very important to cover entire connection completely to prevent an electrochemical action that will cause connection to fail very quickly. Do not reduce effective size of wire, such as cutting off strands so that wire will fit a connector. Proper size connectors should be used. Check all factory and field electrical connections for tightness. This should also be done after unit has reached operating temperatures, especially if aluminum conductors are used.

Contactors

The contactor provides a means of applying power to unit using low voltage (24v) from transformer in order to power contactor coil. Depending on unit model, you may encounter single- or double-pole contactors. Exercise extreme caution when troubleshooting as 1 side of line may be electrically energized. The contactor coil is powered by 24vac. If contactor does not operate:

1. With power off, check whether contacts are free to move. Check for severe burning or arcing on contact points.
2. With power off, use ohmmeter to check for continuity of coil. Disconnect leads before checking. A low resistance reading is normal. Do not look for a specific value, as different part numbers will have different resistance values.
3. Reconnect leads and apply low-voltage power to contactor coil. This may be done by leaving high-voltage power to outdoor unit off and turning thermostat to cooling. Check voltage at coil with voltmeter. Reading should be between 20v and 30v. Contactor should pull in if voltage is correct and coil is good. If contactor does not pull in, replace contactor.

4. With high-voltage power off and contacts pulled in, check for continuity across contacts with ohmmeter. A very low or 0 resistance should be read. Higher readings could indicate burned or pitted contacts which may cause future failures.

Capacitor

WARNING

ELECTRICAL SHOCK HAZARD

Failure to follow this warning could result in personal injury or equipment damage.

Capacitors can store electrical energy when power is off. Electrical shock can result if you touch the capacitor terminals and discharge the stored energy. Exercise extreme caution when working near capacitors. With power off, discharge stored energy by shorting across the capacitor terminals with a 15,000-ohm, 2-watt resistor.

NOTE: If bleed resistor is wired across start capacitor, it must be disconnected to avoid erroneous readings when ohmmeter is applied across capacitor.

WARNING

ELECTRICAL SHOCK HAZARD

Failure to follow this warning could result in personal injury or equipment damage.

Always check capacitors with power off. Attempting to troubleshoot a capacitor with power on can be dangerous. Defective capacitors may explode when power is applied. Insulating fluid inside is combustible and may ignite, causing burns.

Capacitors are used as a phase-shifting device to aid in starting certain single-phase motors. Check capacitors as follows:

NOTE: ECM motors do NOT use capacitors.

1. With power off, discharge capacitors as outlined above. Disconnect capacitor from circuit. Put ohmmeter on R X 10k scale. Using an analog ohmmeter, check each terminal to ground (use capacitor case). Discard any capacitor which measures 1/2 scale deflection or less. Place ohmmeter leads across capacitor and place on R X 10k scale. Meter should jump to a low resistance value and slowly climb to higher value. Failure of meter to do this indicates an open capacitor. If resistance stays at 0 or a low value, capacitor is internally shorted.
2. Capacitance testers are available which will read value of capacitor. If value is not within ± 10 percent value stated on capacitor, it should be replaced. If capacitor is not open or shorted, the capacitance value is calculated by measuring voltage across capacitor and current it draws.

WARNING

ELECTRICAL SHOCK HAZARD

Failure to follow this warning could result in personal injury or death. Exercise extreme caution when taking readings while power is on.

Use following formula to calculate capacitance:

Capacitance (mfd) = (2650 X amps)/volts

3. Remove any capacitor that shows signs of bulging, dents, or leaking. Do not apply power to a defective capacitor as it may explode.

Sometimes under adverse conditions, a standard run capacitor in a system is inadequate to start compressor. In these instances, a start assist device is used to provide an extra starting boost to compressor motor. This device is called a positive temperature coefficient (PTC) or start thermistor. It is a resistor wired in parallel with the run capacitor. As current flows through the PTC at start-up, it heats up. As PTC heats up, its resistance increases greatly until it effectively lowers the current through itself to an extremely low value. This, in effect, removes the PTC from the circuit.

After system shutdown, resistor cools and resistance value returns to normal until next time system starts. Thermistor device is adequate for most conditions, however, in systems where off cycle is short, device cannot fully cool and becomes less effective as a start device. It is an easy device to troubleshoot. Shut off all power to system.

Check thermistor with ohmmeter as described below. Shut off all power to unit. Remove PTC from unit. Wait at least 10 minutes for PTC to cool to ambient temperature.

Measure resistance of PTC with ohmmeter.

The cold resistance (R_T) of any PTC device should be approximately 100-180 percent of device ohm rating.

12.5-ohm PTC = 12.5-22.5 ohm resistance (beige color)

If PTC resistance is appreciably less than rating or more than 200 percent higher than rating, device is defective.

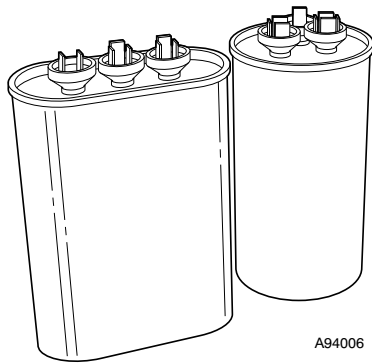

Fig. 4 – Capacitors

A94006

Cycle Protector

ICP thermostats have anti-cycle protection built in to protect the compressor. Should a non-ICP stat be utilized, it is recommended to add a cycle protector to the system. Solid-state cycle protector protects unit compressor by preventing short cycling. After a system shutdown, cycle protector provides for a 5 ± 2 -minute delay before compressor restarts. On normal start-up, a 5-minute delay occurs before thermostat closes. After thermostat closes, cycle protector device provides a 3-sec delay.

Cycle protector is simple to troubleshoot. Only a voltmeter capable of reading 24v is needed. Device is in control circuit, therefore, troubleshooting is safe with control power (24v) on and high-voltage power off.

With high-voltage power off, attach voltmeter leads across T1 and T3, and set thermostat so that Y terminal is energized. Make sure all protective devices in series with Y terminal are closed. Voltmeter should read 24v across T1 and T3. With 24v still applied, move voltmeter leads to T2 and T3. After 5 ± 2 minutes, voltmeter should read 24v, indicating control is functioning normally. If no time delay is encountered or device never times out, change control.

Crankcase Heater

Crankcase heater is a device for keeping compressor oil warm. By keeping oil warm, refrigerant does not migrate to and condense in compressor shell when the compressor is off. This prevents flooded starts which can damage compressor.

On units that have a single-pole contactor, the crankcase heater is wired in parallel with contactor contacts and in series with compressor. (See Fig. 5.) When contacts open, a circuit is completed from line side of contactor, through crankcase heater, through run windings of compressor, and to other side of line. When contacts are closed, there is no circuit through crankcase heater because both leads are connected to same side of line. This allows heater to operate when system is not calling for cooling. The heater does not operate when system is calling for cooling.

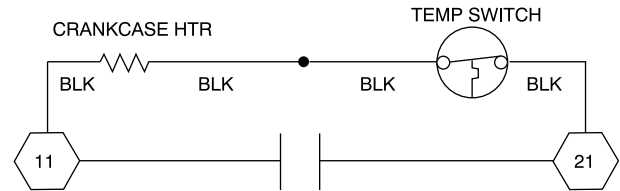

Fig. 5 – Wiring for Single-Pole Contactor

A97586

For 3-phase 460V units, the CCH is controlled by a temperature switch and relay. The relay is controlled by the temperature switch that is wired in series with the low voltage indoor transformer connections, R & C, from the low voltage harness assembly. If the OD ambient is above 85 F, the CCH switch is open and the relay will be de-energized. In this state, the CCH will not be energized. If the OD ambient goes below 65 F and doesn't rise above 85 F, the CCH switch is closed and the relay will be energized. In this state, the CCH will be energized when the compressor contactor is open.

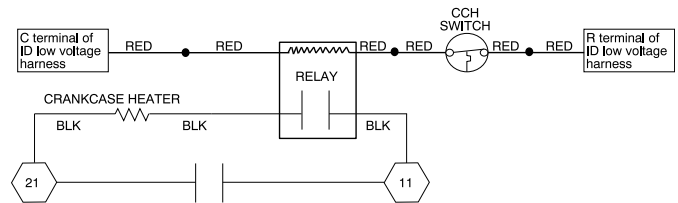

Fig. 6 – Wiring for 3-Phase 460 Volt

A170062

The crankcase heater is powered by high-voltage power of unit. Use extreme caution troubleshooting this device with power on. The easiest method of troubleshooting is to apply voltmeter across crankcase heater leads to see if heater has power. Do not touch heater. Carefully feel area around crankcase heater. If warm, crankcase heater is probably functioning. Do not rely on this method as absolute evidence heater is functioning. If compressor has been running, the area will still be warm.

With power off and heater leads disconnected, check across leads with ohmmeter. Do not look for a specific resistance reading. Check for resistance or an open circuit. Change heater if an open circuit is detected.

Time-Delay Relay (TDR)

The TDR is a solid-state control, recycle delay timer which keeps indoor blower operating for 90 sec after thermostat is satisfied. This delay enables blower to remove residual cooling in coil after compression shutdown, thereby improving efficiency of system. The sequence of operation is that on closure of wall thermostat and at end of a fixed on delay of 1 sec, fan relay is energized. When thermostat is satisfied, an off delay is initiated. When fixed delay of 90 ± 20 sec is completed, fan relay is de-energized and fan motor stops. If wall thermostat closes during this delay, TDR is reset and fan relay remains energized. TDR is a 24v device that operates within a range of 15v to 30v and draws about 0.5 amps. If the blower runs continuously instead of cycling off when the fan switch is set to AUTO, the TDR is probably defective and must be replaced.

Pressure Switches

Pressure switches are protective devices wired into control circuit (low voltage). They shut off compressor if abnormally high or low pressures are present in the refrigeration circuit. R-410A pressure switches are specifically designed to operate with R-410A systems. R-22 pressure switches must not be used as replacements for the R-410A air conditioner or heat pump. R-410A pressure switches are identified by a pink stripe down each wire.

Low-Pressure Switch (AC Only)

The low-pressure switch is located on suction line and protects against low suction pressures caused by such events as loss of charge, low airflow across indoor coil, dirty filters, etc. It opens on a pressure drop at about 50 psig for R-410A and about 27 for R-22. If system pressure is above this, switch should be closed. To check switch:

1. Turn off all power to unit.
2. Disconnect leads on switch.
3. Apply ohmmeter leads across switch. You should have continuity on a good switch.

NOTE: Because these switches are attached to refrigeration system under pressure, it is not advisable to remove this device for troubleshooting unless you are reasonably certain that a problem exists. If switch must be removed, remove and recover all system charge so that pressure gauges read 0 psi. Never open system without breaking vacuum with dry nitrogen.

! CAUTION

PERSONAL INJURY HAZARD

Failure to follow this caution may result in personal injury. Wear safety glasses, protective clothing, and gloves when handling refrigerant.

To replace switch:

1. Apply heat with torch to solder joint and remove switch.

! CAUTION

PERSONAL INJURY HAZARD

Failure to follow this caution may result in personal injury. Wear safety glasses when using torch. Have quenching cloth available. Oil vapor in line may ignite when switch is removed.

2. Braze in 1/4-in. flare fitting and screw on replacement pressure switch.

High-Pressure Switch (AC & HP)

The high-pressure switch is located in liquid line and protects against excessive condenser coil pressure. It opens around 610 to 670 psig for R-410A and 400 psig for R-22 (+/- 10 for both). Switches close at 298 (+/- 20) psig for R-22 and 420 or 470 (+/- 25) psig for R-410A. High pressure may be caused by a dirty condenser coil, failed fan motor, or condenser air re-circulation.

To check switch:

1. Turn off all power to unit.
2. Disconnect leads on switch.
3. Apply ohmmeter leads across switch. You should have continuity on a good switch.

NOTE: Because these switches are attached to refrigeration system under pressure, it is not advisable to remove this device for troubleshooting unless you are reasonably certain that a problem exists. If switch must be removed, remove and recover all system charge so that pressure gauges read 0 psi. Never open system without breaking vacuum with dry nitrogen.

! CAUTION

PERSONAL INJURY HAZARD

Failure to follow this caution may result in personal injury. Wear safety glasses, protective clothing, and gloves when handling refrigerant.

To replace switch:

1. Apply heat with torch to solder joint and remove switch.

! CAUTION

PERSONAL INJURY HAZARD

Failure to follow this caution may result in personal injury. Wear safety glasses when using torch. Have quenching cloth available. Oil vapor in line may ignite when switch is removed.

2. Braze in 1/4-in. flare fitting and replace pressure switch.

Loss of Charge Switch (HP Only)

Located on liquid line of heat pump only, the liquid line pressure switch functions similar to conventional low-pressure switch.

Because heat pumps experience very low suction pressures during normal system operation, a conventional low-pressure switch cannot be installed on suction line. This switch is installed in liquid line instead and acts as loss-of-charge protector. The liquid-line is the low side of the system in heating mode. It operates identically to low-pressure switch except it opens at 23 (+/- 5) psig for R-410A and 7 (+/- 5) psig for R-22 and closes at 55 (+/- 5) psig for R-410A and 22 (+/- 5) psig for R-22. Two-stage heat pumps have the low-pressure switch located on the suction line. The two-stage control board has the capability to ignore low-pressure switch trips during transitional (defrost) operation to avoid nuisance trips. Troubleshooting and removing this switch is identical to procedures used on other switches. Observe same safety precautions.

Defrost Thermostat

Defrost thermostat signals heat pump that conditions are right for defrost or that conditions have changed to terminate defrost. It is a thermally actuated switch clamped to outdoor coil to sense its temperature. Normal temperature range is closed at 32_ + 3°F and open at 65_ + 5°F. Defrost thermostats are used in non-communicating models, a coil temperature thermistor is used in Communicating units.

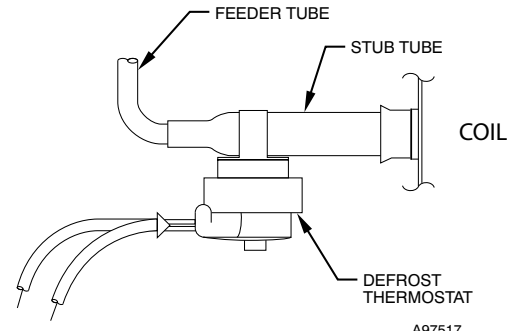

Fig. 7 – Defrost Thermostat Location

A97517

Check Defrost Thermostat

There is a liquid header with a distributor and feeder tube going into outdoor coil. At the end of 1 of the feeder tubes, there is a 3/8-in. OD stub tube approximately 2 in. (50.8 mm) long. (See Fig. 7.) The defrost thermostat should be located on stub tube. Note that there is only 1 stub tube used with a liquid header, and on most units it is the bottom circuit.

NOTE: The defrost thermostat must be located on the liquid side of the outdoor coil on the bottom circuit and as close to the coil as possible. For a copper stub tube, the DFT will have a copper cup. For an aluminum stub tube, the DFT will have an aluminum cup. Don't interchange material types.

Defrost Control Boards

Troubleshooting defrost control involves a series of simple steps that indicate whether or not board is defective.

NOTE: This procedure allows the service technician to check control board and defrost thermostat for defects. First, troubleshoot to make sure unit operates properly in heating and cooling modes. This ensures operational problems are not attributed to the defrost control board.

FAST # 1173636 / 1177927 / 1190281 DEFROST CONTROL

The FAST # 1173636 / 1177927 / 1190281 defrost control is used in all Performance heat pump models. Its features include selectable defrost intervals of 30, 60, 90 minutes, and standard defrost speed up capability. This section describes the sequence of operation and troubleshooting methods for this control.

Cooling Sequence of Operation (FAST # 1173636 / 1177927 / 1190281)

On a call for cooling, thermostat makes R-O, R-Y, and R-G. Circuit R-O energizes reversing valve switching it to cooling position. Circuit R-Y sends low voltage through the safeties and energizes the contactor, which starts the compressor and energizes the T1 terminal on the circuit board. This will energize the OF2 fan relay which starts the outdoor fan motor (ODF relay for 1190281).

When the cycle completes, R-Y is turned off. Compressor and outdoor fan should stop. With ICP thermostats, the O terminal remains energized in the cooling mode. If the mode is switched to heat or Off, the valve is de-energized. There is no compressor delay built into this control.

Heating Sequence of Operation

(FAST # 1173636 / 1177927 / 1190281)

On a call for heating, thermostat makes R-Y, and R-G. Circuit R-Y sends low voltage through the safeties and energizes the contactor, which starts the compressor and energizes the T1 terminal on the circuit board. The T1 terminal energizes the defrost logic. This will energize the OF2 fan relay start the outdoor motor (ODF relay for 1190281). The T1 terminal must be energized for defrost to function.

When the cycle is complete, R-Y is turned off and the compressor and outdoor fan should stop. There is no compressor delay built into this control.

Defrost Sequence (FAST # 1173636 / 1177927 / 1190281)

The defrost control is a time/temperature control that has field selectable settings of 30, 60, and 90 minutes. These represent the amount of time that must pass after closure of the defrost thermostat before the defrost sequence begins.

The defrost thermostat senses coil temperature throughout the heating cycle. When the coil temperature reaches the defrost thermostat setting of approximately 32°F it will close, which energizes the DFT terminal and begins the defrost timing sequence. When the DTF has been energized for the selected time, the defrost cycle begins, and the control shifts the reversing valve into cooling position, and turns the outdoor fan off. This shifts hot gas flow into the outdoor coil which melts the frost from the coil. The defrost cycle is terminated when defrost thermostat opens at approximately 65°F, or automatically after 10 minutes.

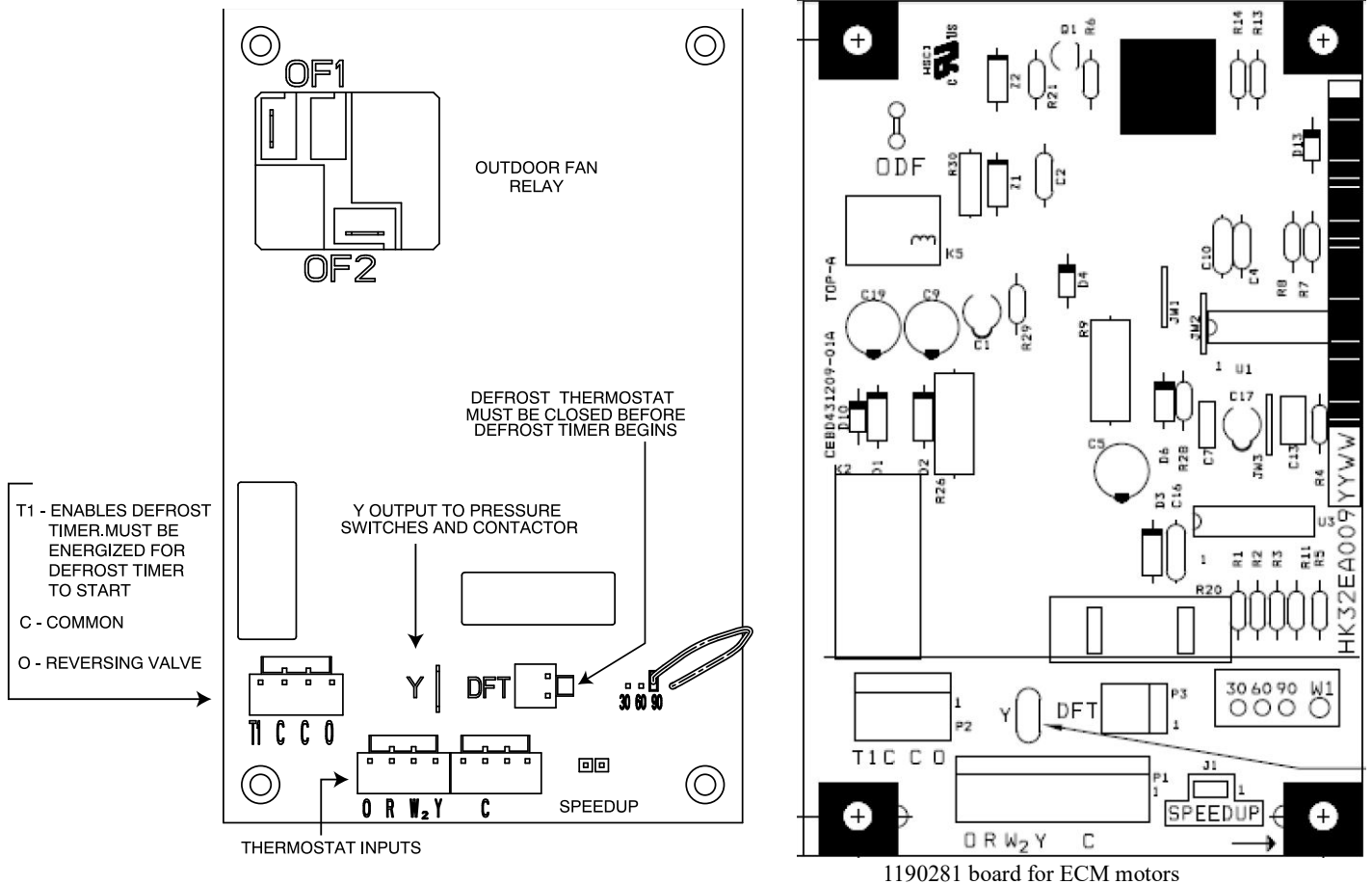

Fig. 8 – FAST # 1173636 / 1177927 / 1190281 Defrost Control

A1150020 / A170235

Troubleshooting (FAST # 1173636 / 1177927 / 1190281)**If outdoor unit will not run:**

1. Does the Y input has 24 volts from thermostat? If not, check thermostat or wire. If yes proceed to #2
2. The Y spade terminal on the circuit board should have 24 volts if Y input is energized. This output goes through the pressure switches and to the contactor. If 24 volts is present on the Y spade terminal, and the contactor is not closed, check voltage on contactor coil. If no voltage is present, check for opened pressure switch.
3. If voltage is present and contactor is open, contactor may be defective. Replace contactor if necessary.
4. If contactor is closed and unit will still not run, check wiring, capacitor and compressor

Defrost Speedup (FAST # 1173636 / 1177927 / 1190281)

To test the defrost function on these units, speed up pins are provided on the circuit board. To force a defrost cycle, the defrost thermostat must be closed, or the defrost thermostat pins must be jumpered. Follow the steps below to force a defrost cycle:

1. Jumper the DFT input
2. Short the speed up pins. This speeds up the defrost timer by a factor of 256. The longer the defrost interval setting, the longer the pins must be shorted to speed through the timing. For example, if interval is 90 min, the speed up will take $(90/256)\text{min} \times (60\text{seconds}/\text{minute}) = 21$ seconds max. This could be shorter depending on how much time has elapsed since the defrost thermostat closed.
3. Remove the short immediately when the unit shifts into defrost. Failure to remove the short immediately will result in a very short forced defrost cycle (the 10 minute timer will be sped through in 2 seconds)
4. When defrost begins, it will continue until the defrost thermostat opens or 10 minutes has elapsed.

NOTE: The T1 terminal on the defrost board powers the defrost timing function. This terminal must be energized before any defrost function will occur.

If defrost thermostat is stuck closed:

Whether the unit is in heating or cooling mode, it will run a defrost cycle for 10 minutes each time the compressor has been energized for the selected time interval. The board will terminate automatically after 10 minutes of defrost time regardless of defrost thermostat position.

If defrost thermostat is stuck open:

The unit will not defrost

NOTE: Unit will remain in defrost until defrost thermostat reopens at approximately 65°F coil temperature at liquid line or remainder of defrost cycle time.

5. Turn off power to outdoor unit and reconnect fan-motor lead to OF2 on control board after above forced-defrost cycle.

If unit will not defrost:

1. Perform the speedup function as described above to test the defrost function of the circuit board.
2. If the unit does not go into defrost after performing the speed up, check for 24 volts on the T1 terminal. This terminal powers the defrost circuit, and must be energized before any defrost function can occur. The T1 should be energized once the Y terminal is energized and the pressure switches are closed. Ensure the T1 wire is connected at the contactor, and that 24 volts is present on the T1 spade terminal.
3. If all voltages are present and unit will still not run defrost, remove thermostat pigtail harness from board and perform checks directly on input pins with jumper wires. The pigtail may have a bad connection or be mis-wired.

To fully troubleshoot defrost thermostat and control function (FAST # 1173636 / 1177927 / 1190281):

1. Turn thermostat to OFF. Shut off all power to outdoor unit.
2. Remove control box cover for access to electrical components and defrost control board.
3. Disconnect defrost thermostat leads from control board, and connect to ohmmeter. Thermostat leads are black, insulated wires connected to DFT and R terminals on control board. Resistance reading may be zero (indicating closed defrost thermostat), or Communicating (∞ for open thermostat) depending on outdoor temperature.
4. Jumper between DFT and R terminals on control board as shown in Fig. 8.
5. Disconnect outdoor fan motor lead from OF2. Tape lead to prevent grounding.
6. Turn on power to outdoor unit.
7. Restart unit in heating mode, allowing frost to accumulate on outdoor coil.
8. After a few minutes in heating mode, liquid line temperature at defrost thermostat should drop below closing set point of defrost thermostat of approximately 32°F. Check resistance across defrost thermostat leads using ohmmeter. Resistance of zero indicates defrost thermostat is closed and operating properly.
9. Short between the speed-up terminals using a thermostat screwdriver. This reduces the timing sequence to 1/256 of original time. (See Table 2.)

Table 2 – Defrost Control Speed-Up Timing Sequence

PARAMETER	MINIMUM (MINUTES)	MAXIMUM (MINUTES)	SPEED-UP (NOMINAL)
30-minute cycle	27	33	7 sec
60-minute cycle	56	66	14 sec
90-minute cycle	81	99	21 sec
10-minute cycle	9	11	2 sec
5-minutes	4.5	5.5	1 sec

CAUTION**UNIT DAMAGE HAZARD**

Failure to follow this caution may result in equipment damage or improper operation.

Exercise extreme caution when shorting speed-up pins. If pins are accidentally shorted to other terminals, damage to the control board will occur.

10. Unit is now operating in defrost mode. Check between C and W2 using voltmeter. Reading on voltmeter should indicate 24v. This step ensures defrost relay contacts have closed, energizing supplemental heat (W2) and reversing valve solenoid (O).
11. Unit should remain in defrost no longer than 10 minutes. Actual time in defrost depends on how quickly speed-up jumper is removed. If it takes 2 sec to remove speed-up jumper after unit has switched to defrost, the unit will switch back to heat mode.
12. After a few minutes, in defrost (cooling) operation, liquid line should be warm enough to have caused defrost thermostat contacts to open. Check resistance across defrost thermostat. Ohmmeter should read infinite resistance, indicating defrost thermostat has opened at approximately 65°F.
13. Shut off unit power and reconnect fan lead.
14. Remove jumper between DFT and R terminals. Reconnect defrost thermostat leads. Failure to remove jumper causes unit to switch to defrost every 30, 60, or 90 minutes and remain in defrost for full 10 minutes.

15. Replace control box cover. Restore power to unit.

If defrost thermostat does not check out following above items or incorrect calibration is suspected, check for defective thermostat as follows:

1. Follow items 1-5 above.
2. Route sensor or probe underneath coil (or other convenient location) using thermocouple temperature measuring device. Attach to liquid line near defrost thermostat. Insulate for more accurate reading.
3. Turn on power to outdoor unit.
4. Restart unit in heating.
5. Within a few minutes, liquid line temperature drops within a range causing defrost thermostat contacts to close. Temperature range is from 33°F to 27°F. Notice temperature at which ohmmeter reading goes from ∞ to zero ohms. Thermostat contacts close at this point.
6. Short between the speed-up terminals using a small slotted screwdriver.
7. Unit changes over to defrost within 21 sec (depending on timing cycle setting). Liquid line temperature rises to range where defrost thermostat contacts open. Temperature range is from 60°F to 70°F. Resistance goes from zero to ∞ when contacts are open.
8. If either opening or closing temperature does not fall within above ranges or thermostat sticks in 1 position, replace thermostat to ensure proper defrost operation.

NOTE: With timing cycle set at 90 minutes, unit initiates defrost within approximately 21 sec. When you hear the reversing valve changing position, remove screwdriver immediately. Otherwise, control will terminate normal 10-minute defrost cycle in approximately 2 sec.

DEFROST CONTROL (Fast # 1174185)

This defrost control is used in most Performance Series heat pumps with R-410A refrigerant. Its features include selectable defrost intervals of 30, 60, 90, & 120 minutes, Quiet Shift, compressor time delay, deluxe defrost speed up capability. This section describes the sequence of operation and trouble shooting methods for this control.

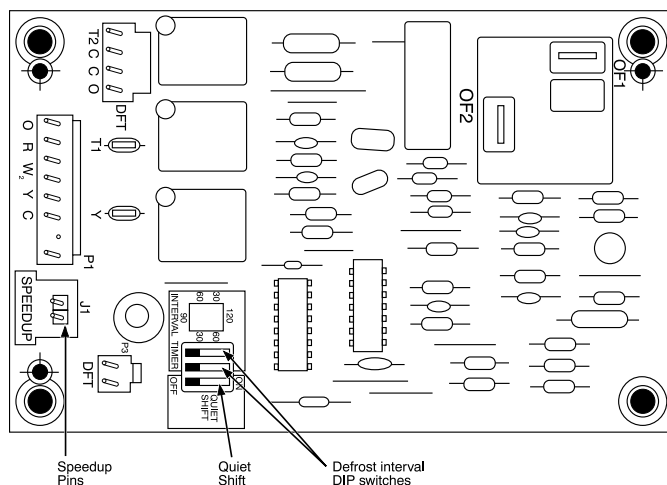

Fig. 9 – 1174185 Defrost Control

A05378

Quiet Shift (Fast # 1174185)

This control has the option of shutting down the compressor for 30 seconds going in and coming out of defrost. This is accomplished by turning DIP switch 3 to the ON position. Factory default is in the OFF position. Enabling this feature eliminates occasional noise complaints associated with switching into and out of defrost.

Five-Minute Compressor Delay (Fast # 1174185)

This control features a 5-minute time delay to protect the compressor from short cycling. The delay begins counting when the low voltage is interrupted, and at the end of heating or cooling cycle.

System Function and Sequence of Operation (Fast # 1174185)

On power-up (24 volts between R-C) the 5 minute cycle timer begins counting down. The compressor will not be energized until this timer is elapsed.

Cooling

On a call for cooling, thermostat makes R-O, R-Y, and R-G. Circuit R-O energizes reversing valve switching it to cooling position. Circuit R-Y sends low voltage through the safeties and energizes the T1 terminal on the circuit board. If the compressor has been off for 5 minutes, or power has not been cycled for 5 minutes, the OF2 relay and T2 terminal will energize. This will close the contactor, start the outdoor fan motor and compressor.

When the cycle is complete, R-Y is turned off and compressor and outdoor fan should stop. When using ICP thermostats, the reversing valve remains energized in the cooling mode until the thermostat is switched to heat, or the mode it turned off. The 5-minute time guard begins counting. Compressor will not come on again until this time delay expires. In the event of a power interruption, the time guard will not allow another cycle for 5 minutes.

Heating

On a call for heating, thermostat makes R-Y, and R-G. Circuit R-Y sends low voltage through the safeties and energizes the T1 terminal on the circuit board. T1 energizes the defrost logic circuit. If the compressor has been off for 5 minutes, or power has not been cycled for 5 minutes, the OF2 relay and T2 terminal will energize. This will close the contactor, start the outdoor fan motor and compressor.

When the cycle is complete, R-Y is turned off and the compressor and outdoor fan should stop. The 5 minute time guard begins counting. Compressor will not come on again until this time delay expires. In the event of a power interruption, the time guard will not allow another cycle for 5 minutes.

Defrost Sequence

The defrost control is a time/temperature control that has field selectable settings of 30, 60, 90 and 120 minutes. These represent the amount of time that must pass after closure of the defrost thermostat before the defrost sequence begins.

The defrost thermostat senses coil temperature throughout the heating cycle. When the coil temperature reaches the defrost thermostat setting of approximately 32 degrees F, it will close, which energizes the DFT terminal and begins the defrost timing sequence. When the DTF has been energized for the selected time, the defrost cycle begins. If the defrost thermostat opens before the timer expires, the timing sequence is reset.

Defrost cycle is terminated when defrost thermostat opens (~65 degrees) or automatically after 10 minutes.

Deluxe Defrost Speedup

To initiate a force defrost, speedup pins (J1) must be shorted with a flat head screwdriver for 5 seconds and RELEASED. If the defrost thermostat is open, a short defrost cycle will be observed (actual length depends on Quiet Shift switch position). When Quiet Shift is off, only a short 30 second defrost cycle is observed. With Quiet Shift ON, the speed up sequence is one minute; 30 second compressor off period followed by 30 seconds of defrost with compressor operation. When returning to heating mode, the compressor will turn off for an additional 30 seconds and the fan for 40 seconds.

If the defrost thermostat is closed, a complete defrost cycle is initiated. If the Quiet Shift switch is turned on, the compressor will be turned off for two 30 second intervals as explained previously.

Troubleshooting (Fast # 1174185)

If outdoor unit will not run:

1. Does the Y input have 24 volts from thermostat? If not, check thermostat or wire. If yes proceed to #2
2. The Y spade terminal should have 24 volts if Y input is energized. This output goes through the pressure switches and back to the T1 input to energize the time delay and defrost timing circuit. If the contactor is not closed, the time delay may still be active. Defeat time delay by shorting speed up pins for 1 second. Be sure not to short more than 1 second.
3. Once time delay has elapsed voltage on T2 should energize contactor with 24v. Check voltage on contactor coil. If no voltage is present, check for opened pressure switch.
4. If voltage is present and contactor is open, contactor may be defective. Replace contactor
5. If contactor is closed and unit will still not run, check capacitor and compressor.

If unit will not go into defrost:

1. Perform speedup function as described above to test the defrost function of the circuit board.
2. If the unit will go into defrost with the speed up, but will not on its own, the defrost thermostat may not be functioning properly. Perform the full defrost thermostat and board troubleshooting the same as described for the FAST# 1173636 / 1177927 control. Other than the Quiet shift (if selected), and the speedup timing, the troubleshooting process is identical.
3. If unit still will not run defrost, remove thermostat pigtail harness from board and perform checks directly on input pins with jumper wires. The pigtail may have a bad connection or be mis-wired.

FAST# 1185790 DEFROST CONTROL

This defrost control is used in most non-communicating Performance Series heat pumps with R-410A refrigerant and has all the same functionality, speedups, troubleshooting as the FAST# 1174185 except for the forced defrost timing when Quiet Shift-2 is enabled.

Quiet Shift-2 (non-communicating)

Quiet shift-2 is a field selectable defrost mode (factory set to OFF), which will reduce the occasional noise that could be heard at the start of defrost cycle and restarting of heating cycle. It is selected by placing DIP switch 3 on defrost board in the ON position.

When Quiet Shift-2 switch is placed in ON position, and defrost is initiated, the following sequence of operation will occur: The compressor will be de-energized for approximately 1 minute, then the reversing valve will be energized. A few seconds later, the compressor will be re-energized and the normal defrost cycle starts. Once defrost termination conditions have been met, the following sequence will occur: The compressor will be de-energized for approximately 1 minute, then the reversing valve will be de-energized. A few seconds later, the compressor will be re-energized and the normal heating cycle starts.

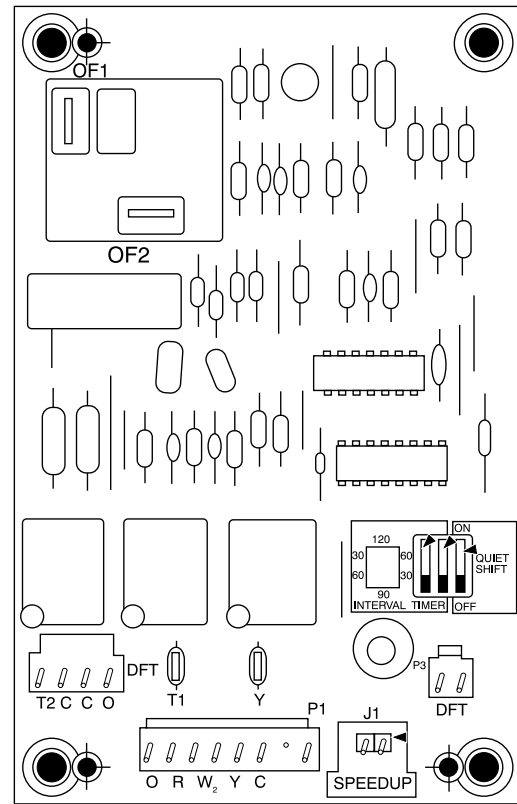

Fig. 10 – FAST# 1185790 Defrost Control

A05378A

ECM Fan Motor (single stage equipment)

Some single stage outdoor units will be equipped with ECM fan motors. For suspected ECM motor electrical failures, first check for loose or faulty electrical connections. ECM motors are not wired to the capacitor. A reference for the wires is listed in the table below:

Table 3 – ECM Fan Motor Wires

TERMINAL	DESCRIPTION	COLOR
1/4" Non insulated Q.C.	Speed, Common (low Voltage)	BRN/YEL
1/4" Insulated Q.C.	AC line (high voltage)	YEL
1/4" Non insulated Q.C.	Speed (low voltage)	BLU/YEL
#8 Non insulated ring	Ground	GRN/YEL
1/4" Insulated Q.C.	AC line (high voltage)	BLK

The low voltage wires should see 24VAC when the contactor is engaged. The high voltage wires should see 230VAC as long as 230VAC is being supplied to the field side of the contactor. The ECM motor will not operate unless both 24VAC and 230VAC are being supplied. Refer to the wiring diagram to determine where each wire should be connected to the contactor. If connections are secure, the motor is wired properly, proper voltages are present, and the ECM motor is still not operational, replace the ECM motor.

If utilizing a low ambient cooling kit, the ECM motor will not function properly. The ECM motor will need to be replaced with a PSC fan motor and fan blade specified in the accessory lists for the unit and wired per the wiring diagram.

If the outdoor ECM fan motor fails to start and run:

- Check the high-voltage supply. The unit need not be running to check high voltage, but the power must be on.
- If the 230vac is present, disconnect the blu/yel wire from ODF on the control board, and the brn/yel wire from the contactor coil. Set a voltmeter on an AC voltage scale and check across the ODF terminal on the control board and the coil terminal on the contactor. There should be a control signal reading of 24vac.

- First check voltage with the motor disconnected. If no control voltage is present, check control-board connections. If connections are good, replace the control board.
- If voltage is present, reconnect the motor and check again. Shut down the unit to reconnect the motor and restart the unit to complete this troubleshooting procedure. If control voltage is no longer present or motor fails to respond, check motor connections.
- If connections are good, replace the motor.

PSC Fan Motor

The fan motor rotates the fan blade that draws air through the outdoor coil to exchange heat between the refrigerant and the air. Motors are totally enclosed to increase reliability. This eliminates the need for a rain shield. For the correct position of fan blade assembly, the fan hub should be flush with the motor shaft. Replacement motors and blades may vary slightly.

⚠ WARNING

ELECTRICAL SHOCK HAZARD

Failure to follow this warning could result in personal injury or death. Turn off all power before servicing or replacing fan motor. Be sure unit main power switch is turned off.

The bearings are permanently lubricated; therefore, no oil ports are provided.

For suspected electrical failures, check for loose or faulty electrical connections, or defective fan motor capacitor. The fan motor is equipped with a thermal overload device in the motor windings which may open under adverse operating conditions. Allow time for the motor to cool so the device can reset. Further checking of the motor can be done with an ohmmeter. Set the scale on R X 1 position, and check for continuity between 3 leads. Replace motors that show an open circuit in any of the windings. Place 1 lead of the ohmmeter on each motor lead. At the same time, place the other ohmmeter lead on the motor case (ground). Replace any motor that shows resistance to ground, arcing, burning, or overheating.

Compressor Plug

The compressor electrical plug provides a quick-tight connection to compressor terminals. The plug completely covers the compressor terminals and the mating female terminals are completely encapsulated in plug. Therefore, terminals are isolated from any moisture so corrosion and resultant pitted or discolored terminals are reduced. The plug is oriented to relief slot in terminal box so cover cannot be secured if wires are not positioned in slot, assuring correct electrical connection at the compressor. The plug can be removed by simultaneously pulling while “rocking” plug. However, these plugs can be used only on specific compressors. The configuration around the fusite terminals is outlined on the terminal covers. The slot through which wires of plug are routed is oriented on the bottom and slightly to the left. The correct plug can be connected easily to compressor terminals and plug wires can easily be routed through slot terminal cover.

It is strongly recommended to replace the compressor plug should a compressor fail due to a suspected electrical failure. At a minimum, inspect plug for proper connection and good condition on any compressor replacement.

Low-Voltage Terminals

The low-voltage terminal designations, and their description and function, are used on all split-system condensers.

W—Energizes first-stage supplemental heat through defrost relay (wht).

R—Energizes 24-v power from transformer (red).

Y—Energizes contactor for first-stage cooling or first-stage heating for heat pumps (yel).

O—Energizes reversing valve on heat pumps (orn).

C—Common side of transformer (blk).

COPELAND SCROLL COMPRESSOR

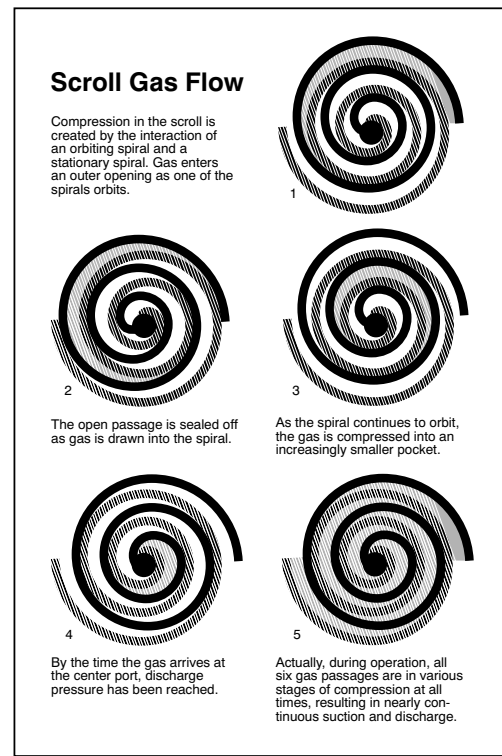

Fig. 11 – Scroll Compressor Refrigerant Flow

A90198

The compressors used in these products are specifically designed to operate with designated refrigerant and cannot be interchanged. The compressor is an electrical (as well as mechanical) device. Exercise extreme caution when working near compressors. Power should be shut off, if possible, for most troubleshooting techniques. Refrigerants present additional safety hazards.

⚠ CAUTION

PERSONAL INJURY HAZARD

Failure to follow this caution may result in personal injury.

Wear safety glasses, protective clothing, and gloves when handling refrigerant.

The scroll compressor pumps refrigerant through the system by the interaction of a stationary and an orbiting scroll. (See Fig. 11.) The scroll compressor has no dynamic suction or discharge valves, and it is more tolerant of stresses caused by debris, liquid slugging, and flooded starts. The compressor is equipped with an internal pressure relief port. The pressure relief port is a safety device, designed to protect against extreme high pressure. The relief port has an operating range between 550 to 625 psi differential pressure for R-410A and 350 to 450 psi differential pressure for R-22. Scrolls have a variety of shut down solutions, depending on model, to prevent backward rotation and eliminate the need for cycle protection.

LG SCROLL COMPRESSOR

The compressors used in these products are specifically designed to operate with designated refrigerants and cannot be interchanged.

LG produced scroll compressors are designed to operate and function as the typical orbiting scroll on a fixed scroll design. Refrigerant flow and compression is basically the same.

Characteristics of the LG Scroll Compressor:

Internal Motor Overload Protection (OLP): This is an inherent protection system sensing both motor winding temperature and motor current. This is designed to open the common wire on single phase units and stop the motor operation if motor high temperature or over current conditions exist. Trip of the OLP opens the common line.

Vacuum protection device: If the suction side of the compressor is blocked or limited, an extremely low vacuum situation is formed by the optimum efficiency of the scrolls. The high vacuum pressure causes the arc at the internal power terminal and cause tripping of the internal overload or breaker or damage to the compressor. This compressor is equipped with internal protection that opens if this high vacuum condition exists and bypasses high pressure gas to the low pressure and the internal overload may trip. In the case of refrigerant pump down, the unit can operate with pump down but this protection may not allow the refrigerant to be pumped down completely.

Internal Pressure Relief (IPR): The internal pressure relief is located between the high and low pressure of the compressor and is designed to open when the difference of the suction and discharge pressure is 500-550 psid. When the IPR valve opens, the high temperature gas bypasses into the motor area and will trip the motor OLP.

Quiet Shut Down Device: The LG scroll has a shut down device to efficiently minimize the shut down sound. The reversing sound is minimized by a check valve located in the discharge port of the scroll sets. This slows the equalization of the high side to low side upon shut down to prevent the scrolls from operating backwards.

Discharge Temperature Protection: The compressor discharge temperature may be monitored by a temperature sensor mounted on the top cap of the compressor. Wire diagrams may refer to this as a discharge temperature switch (DTS). This is to protect against excessively high scroll temperatures due to loss of charge or operating outside the compressor envelope. This temperature sensor opens to stop the compressor if temperatures exceed 239-257°F (115-125°C) and resets at 151-187°F (66-86°C). The DTS will break the Y signal in the 24 volt circuit if it trips open.

NOTE: The LG generation 2 compressor models will not have this temperature switch.

Test sensor wires for continuity, open above 239-257°F (115-125°C) and resets at 151-187°F (66-86°C).

If replacement is deemed necessary, perform the following to replace sensor:

1. Locate top cap and discharge temperature sensor



2. Carefully remove sensor cover

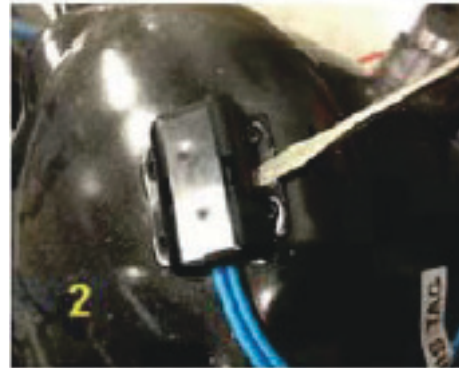

3. Expose the sensor holder



4. Slide out the sensor, slide in replacement and reinstall the cover



A12342

A12343

A12344

A12345

COMPRESSOR TROUBLESHOOTING

Compressor Failures

Compressor failures are classified in 2 broad failure categories; mechanical and electrical. Both types are discussed below.

Mechanical Failures

A compressor is a mechanical pump driven by an electric motor contained in a welded or hermetic shell. In a mechanical failure, motor or electrical circuit appears normal, but compressor does not function normally.

WARNING

ELECTRICAL SHOCK HAZARD

Failure to follow this warning could result in personal injury or death. Do not supply power to unit with compressor terminal box cover removed.

WARNING

ELECTRICAL SHOCK HAZARD

Failure to follow this warning could result in personal injury or death. Exercise extreme caution when reading compressor currents when high-voltage power is on. Correct any of the problems described below before installing and running a replacement compressor.

Locked Rotor

In this type of failure, compressor motor and all starting components are normal. When compressor attempts to start, it draws locked rotor current and cycles off on internal protection. Locked rotor current is measured by applying a clamp-on ammeter around common (blk) lead of compressor. Current drawn when it attempts to start is then measured. Locked rotor amp (LRA) value is stamped on compressor nameplate.

If compressor draws locked rotor amps and all other external sources of problems have been eliminated, compressor must be replaced. Because compressor is a sealed unit, it is impossible to determine exact mechanical failure. However, complete system should be checked for abnormalities such as incorrect refrigerant charge, restrictions, insufficient airflow across indoor or outdoor coil, etc., which could be contributing to the failure.

Runs, Does Not Pump

In this type of failure, compressor motor runs and turns compressor, but compressor does not pump refrigerant. A clamp-on amp meter on common leg shows a very low current draw, much lower than rated load amp (RLA) value stamped on compressor nameplate. Because no refrigerant is being pumped, there is no return gas to cool compressor motor. It eventually overheats and shuts off on its internal protection.

Noisy Compressor

Noise may be caused by a variety of internal and external factors. Careful attention to the “type” of noise may help identify the source. The following are some examples of abnormal conditions that may create objectionable noise:

1. A gurgling sound may indicate a liquid refrigerant floodback during operation. This could be confirmed if there is no compressor superheat. A compressor superheat of “0” degrees would indicate liquid refrigerant returning to the compressor. Most common reasons for floodback are: loss of evaporator blower, dirty coils, and improper airflow.
2. A rattling noise may indicate loose hardware. Inspect all unit hardware including the compressor grommets.
3. A straining (hard start) or vibration occurring at start up but clears quickly after could indicate an off cycle refrigerant migration issue.

Refrigerant migration can occur when a compressor is off and refrigerant vapor transfers from other areas of the system, settles into the compressor as it is attracted to the oil, and then condenses into the oil. Upon start up, the compressor draws suction from within itself first and lowers the boiling point of the refrigerant that is entrained in the oil. This can cause the liquid refrigerant and oil to boil into the compression area or liquid refrigerant to wipe off oil films that are critical for proper lubrication. Migration is worsened by greater temperature differentials and/or extra refrigerant in the system. Prevention of migration can be reduced by various options but some of the more common remedies is to verify proper charge and add a crankcase heater where this situation is suspected.

4. Operational vibration could indicate a charge issue. Verify charge and ensure proper piping and structural penetration insulation. Tubing that is too rigid to building rafters without proper insulation could transfer noise throughout the structure. On some occasions a sound dampener or mass weight (FAST part no. 1185726) placed on the vibrating tubing has been known to reduce this noise. Utilizing compressor split post grommets (see Fig. 13) may also reduce this vibration if piping cannot be remedied.
5. An operational high pitch frequency or “waa waa” sound that appears to resonate through the suction line could indicate a need to add more flex or muffling in the lines. This has been occasional in scroll compressor applications and is usually remedied by adding a field-fabricated suction line loop (see Fig. 14). Reciprocating compressors may have a noticeable discharge pulsation that could be remedied with a field installed discharge muffler. Recommend loop by continuous tubing with no more than 12 inches vertical and 6 inch horizontal loop.
6. An internal “thunking”, “thumping”, “grinding” or “rattling” noise could indicate compressor internal failures and may be verified by comparing the compressor amperage to what the compressor should be drawing according to a manufacturer’s performance data.
7. A whistling or squealing noise during operation may indicate a partial blockage of the refrigerant charge.
8. A whistle on shut down could indicate a partial leak path as refrigerant is equalizing from high to low side. On occasion, an in-line discharge check valve has prevented this sound.
9. If a compressor hums but won’t start it could indicate either a voltage or amperage issue. Verify adequate voltage and operational start components if installed. If it is drawing excessive amperage and voltage doesn’t appear to be the problem it may be assumed a locked condition. Ensure refrigerant has had ample time to equalize and boil out of the compressor before condemning.
10. When a heat pump switches into and out of defrost, a “swooshing” noise is expected due to the rapid pressure change within the system. However customers sometimes complain that the noise is excessive, or it is sometimes accompanied by a “groaning, or howling” noise. When receiving these complaints, Quiet Shift-2 (if available) may improve the noise, but will probably not eliminate it totally. Check that the defrost thermostat or thermistor is operating properly. Insulating the defrost sensing device may also help. If the howling or groaning noise is intermittent, replacing the reversing valve may or may not help.

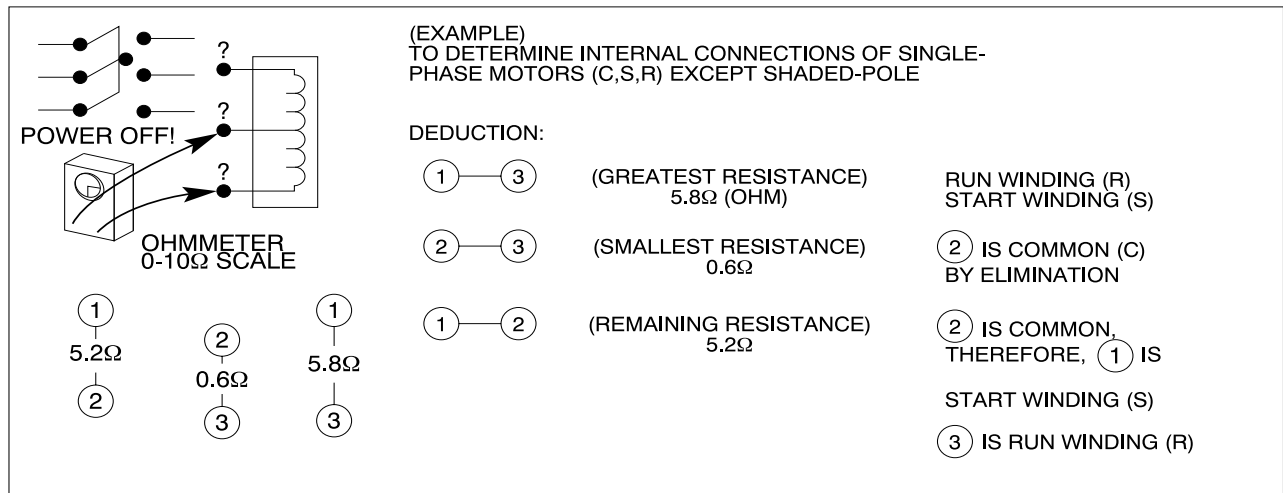

Fig. 12 – Identifying Compressor Terminals

A88344

11. Rattling that occurs during a shift into or out of defrost on a heat pump could indicate a pressure differential issue. This is usually a brief occurrence (under 60 seconds) and can be remedied by incorporating Quiet Shift-2, if available. This is a feature available in communicating heat pumps that shuts down the compressor during the defrost shift for approximately 1 minute allowing the pressures to equalize. It is enabled by either a dip switch setting on the defrost board, or in the wall control on Communicating systems. Verify proper system charge as well.

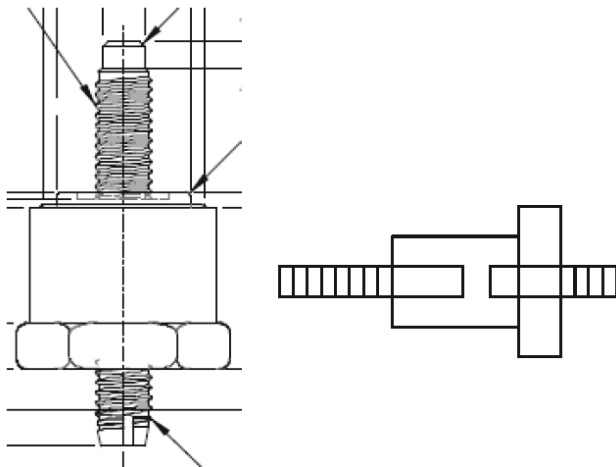
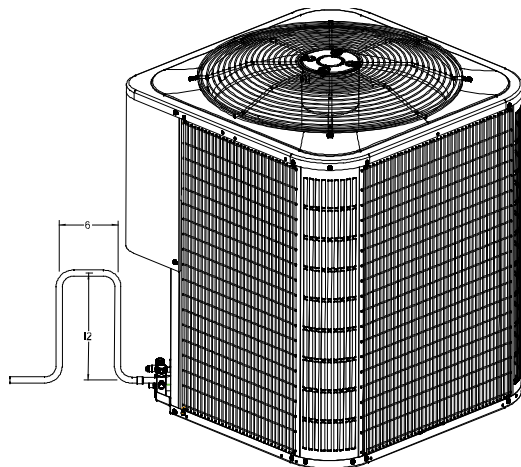

Fig. 13 – Split Post Grommet part number: 1172271

A07124



Note: Long radius elbows recommended

Fig. 14 – Suction Line Loop

A07123

Electrical Failures

The compressor mechanical pump is driven by an electric motor within its hermetic shell. In electrical failures, compressor does not run although external electrical and mechanical systems appear normal. Compressor must be checked electrically for abnormalities.

Before troubleshooting compressor motor, review this description of compressor motor terminal identification.

Single-Phase Motors

To identify terminals C, S, and R:

1. Turn off all unit power.
2. Discharge run and start capacitors to prevent shock.
3. Remove all wires from motor terminals.
4. Read resistance between all pairs of terminals using an ohmmeter on 0-10 ohm scale.
5. Determine 2 terminals that provide greatest resistance reading.

Through elimination, remaining terminal must be common (C). Greatest resistance between common (C) and another terminal indicates the start winding because it has more turns. This terminal is the start (S). The remaining terminal will be run winding (R).

NOTE: If compressor is hot, allow time to cool and internal line break to reset. There is an internal line break protector which must be closed.

All compressors are equipped with internal motor protection. If motor becomes hot for any reason, protector opens. Compressor should always be allowed to cool and protector to close before troubleshooting. Always turn off all power to unit and disconnect leads at compressor terminals before taking readings.

Most common motor failures are due to either an open, grounded, or short circuit. When a compressor fails to start or run, 3 tests can help determine the problem. First, all possible external causes should be eliminated, such as overloads, improper voltage, pressure equalization, defective capacitor(s), relays, wiring, etc. Compressor has internal line break overload, so be certain it is closed.

Open Circuit

WARNING

UNIT PERSONAL INJURY HAZARD

Failure to follow this warning could result in personal injury. Use caution when working near compressor terminals. Damaged terminals have the potential to cause personal injury. Never put face or body directly in line with terminals.

To determine if any winding has a break in the internal wires and current is unable to pass through, follow these steps:

1. Be sure all power is off.
2. Discharge all capacitors.
3. Remove wires from terminals C, S, and R.
4. Check resistance from C-R, C-S, and R-S using an ohmmeter on 0-1000 ohm scale.

Because winding resistances are usually less than 10 ohms, each reading appears to be approximately 0 ohm. If resistance remains at 1000 ohms, an open or break exists and compressor should be replaced.

CAUTION

UNIT DAMAGE HAZARD

Failure to follow this caution may result in equipment damage or improper operation. Be sure internal line break overload is not temporarily open.

Ground Circuit

To determine if a wire has broken or come in direct contact with shell, causing a direct short to ground, follow these steps:

1. Allow crankcase heaters to remain on for several hours before checking motor to ensure windings are not saturated with refrigerant.
2. Using an ohmmeter on R X 10,000 ohm scale or megohmmeter (follow manufacturer's instructions).
3. Be sure all power is off.
4. Discharge all capacitors.
5. Remove wires from terminals C, S, and R.
6. Place one meter probe on ground or on compressor shell. Make a good metal-to-metal contact. Place other probe on terminals C, S, and R in sequence.
7. Note meter scale.
8. If reading of 0 or low resistance is obtained, motor is grounded. Replace compressor.

Compressor resistance to ground should not be less than 1000 ohms per volt of operating voltage.

Example:

$$230 \text{ volts} \times 1000 \text{ ohms/volt} = 230,000 \text{ ohms minimum.}$$

Short Circuit

To determine if any wires within windings have broken through their insulation and made contact with other wires, thereby shorting all or part of the winding(s), be sure the following conditions are met.

1. Correct motor winding resistances must be known before testing, either from previous readings or from manufacturer's specifications.
2. Temperature of windings must be as specified, usually about 70°F.
3. Resistance measuring instrument must have an accuracy within ± 5-10 percent. This requires an accurate ohmmeter such as a Wheatstone bridge or null balance-type instrument.
4. Motor must be dry or free from direct contact with liquid refrigerant.

Make This Critical Test

(Not advisable unless above conditions are met)

1. Be sure all power is off.
2. Discharge all capacitors.
3. Remove wires from terminals C, S, and R.
4. Place instrument probes together and determine probe and lead wire resistance.
5. Check resistance readings from C-R, C-S, and R-S.
6. Subtract instrument probe and lead resistance from each reading.

If any reading is within ±20 percent of known resistance, motor is probably normal. Usually a considerable difference in reading is noted if a turn-to-turn short is present.

REFRIGERATION SYSTEM

Refrigerant

WARNING

UNIT OPERATION AND SAFETY HAZARD

Failure to follow this warning could result in personal injury or equipment damage.

R-410A refrigerant which has higher pressures than R-22 and other refrigerants. No other refrigerant may be used in this system. Gauge set, hoses, and recovery system must be designed to handle R-410A. If you are unsure consult the equipment manufacturer.

CAUTION

UNIT DAMAGE HAZARD

Failure to follow this caution may result in equipment damage or improper operation.

The compressor in a R-410A system uses a polyol ester (POE) oil. This oil is extremely hygroscopic, meaning it absorbs water readily. POE oils can absorb 15 times as much water as other oils designed for HCFC and CFC refrigerants. Take all necessary precautions to avoid exposure of the oil to the atmosphere.

In an air conditioning and heat pump system, refrigerant transfers heat from one place to another. The condenser is the outdoor coil in the cooling mode and the evaporator is the indoor coil.

In a heat pump, the condenser is the indoor coil in the heating mode and the evaporator is the outdoor coil.

In the typical air conditioning mode, compressed hot gas leaves the compressor and enters the condensing coil. As gas passes through the condenser coil, it rejects heat and condenses into liquid. The liquid leaves condensing unit through liquid line and enters metering device at evaporator coil. As it passes through metering device, it becomes a gas-liquid mixture. As it passes through indoor coil, it absorbs heat and the refrigerant moves to the compressor and is again compressed to hot gas, and cycle repeats.

Servicing Systems on Roofs With Synthetic Materials

POE (polyol ester) compressor lubricants are known to cause long term damage to some synthetic roofing materials. Exposure, even if immediately cleaned up, may cause embrittlement (leading to cracking) to occur in one year or more. When performing any service which may risk exposure of compressor oil to the roof, take appropriate precautions to protect roofing. Procedures which risk oil leakage include but are not limited to compressor replacement, repairing refrigerants leaks, replacing refrigerant components such as filter drier, pressure switch, metering device, coil, accumulator, or reversing valve.

Synthetic Roof Precautionary Procedure

1. Cover extended roof working area with an impermeable polyethylene (plastic) drop cloth or tarp. Cover an approximate 10 x 10 ft area.
2. Cover area in front of the unit service panel with a terry cloth shop towel to absorb lubricant spills and prevent run-offs, and protect drop cloth from tears caused by tools or components.
3. Place terry cloth shop towel inside unit immediately under component(s) to be serviced and prevent lubricant run-offs through the louvered openings in the base pan.
4. Perform required service.
5. Remove and dispose of any oil contaminated material per local codes.

Brazing

This section on brazing is not intended to teach a technician how to braze. There are books and classes which teach and refine brazing techniques. The basic points below are listed only as a reminder.

Definition: The joining and sealing of metals using a nonferrous metal having a melting point over 800°F/426.6°C.

Flux: A cleaning solution applied to tubing or wire before it is brazed. Flux improves the strength of the brazed connection.

When brazing is required in the refrigeration system, certain basics should be remembered. The following are a few of the basic rules.

1. Clean joints make the best joints. To clean:
 - Remove all oxidation from surfaces to a shiny finish before brazing.
 - Remove all flux residue with brush and water while material is still hot.
2. Silver brazing alloy is used on copper-to-brass, copper-to-steel, or copper-to-copper. Flux is required when using silver brazing alloy. Do not use low temperature solder.
3. Use flux carefully. Avoid excessive application and do not allow fluxes to enter into the system.
4. Brazing temperature of copper is proper when it is heated to a minimum temperature of 800°F and it is a dull red color in appearance.

Aluminum Brazing

This field repair procedure is intended for aluminum coil product group that have acquired mechanical damage. This procedure is limited to repairing self-tapping screw holes and punctures, not to exceed 0.182" along its largest axis if non circular, and 0.182" diameter if circular. Brazing kit p/n 1184905 is available from FAST Parts.

Coil replacement is needed if at least one of the following is present:

- Corrosion cracks and burst cracks
- A singular tube with more than 2 holes
- Holes that exceed .182" largest axis if non circular and .182" dia. if circular.

The key to brazing aluminum is watching the flame change in color. Any fuel gas/oxygen flame in the neutral state will produce a flame that is a shade of blue. As the aluminum heats up to temperature, you will see the flame change in color to red/orange.

The change in color indicates the base metal is at temperature ready for braze material. Continuing to apply heat will not change the color and will melt the base metal.

The braze alloys should not have direct contact with the flame. In cored wire filler metals, you will notice that the filler metal will melt away exposing the flux. The flux change in state is from white liquid, to dry white, to clear liquid. The change in state of flux coincides with the flame change in color. The addition of flux will minimize the flame change in color. The alloy is ready to apply when the flux is in the clear state.

Most aluminum alloys melt at 1200°F, and the braze materials melt between 905°F and 1080°F. The zinc alloys (ZA-1) melt at a lower temperature while alloys which have more aluminum content melt at a higher temperature.

Materials:

1. 78/22 braze alloy Channel Flux ZA-1, Harris AlGroove900 cored wire
2. Flux CX-60 Omni / Lucas product
3. Stainless steel wire brushes small handle / rotary brush
4. Turbo-Torch equipment

Aluminum Brazing Instructions:

1. Clean area to be brazed
 - Joint must be free of oil, grease, rust, corrosion, and refrigerant.
2. Wire brush to remove oxides from area
3. Flux area if required with the CX-60 flux. Cored wire alloys will not need fluxing.
 - Additional flux with cored filler will aid in dirty conditions
4. Depending on thickness of material, select an appropriate torch tip size.
 - Turbo torch standard nozzles work well for aluminum repair

NOTE: It is important to size the torch tip to the thickness of material. Example: too large a torch tip will melt the aluminum base metal before you are able to repair it.

5. Heat area until flux turns clear or you see flame change in color.
6. Continue to heat the joint and test by wiping the braze rod across the joint.
7. Once the alloy melts on the parent metal add alloy to repair the area. **Maintain joint temperature until repair is complete. Do not over heat. (withdraw torch as required)**
8. It is best to repair the area the first time. Reheating can cause failure to repair the area.
9. If reheating is necessary, let joint cool, wire brush, reapply flux. Reheat joint so flux melts and reapply braze material.

Service Valves and Pumpdown



WARNING

PERSONAL INJURY AND UNIT DAMAGE HAZARD

Failure to follow this warning could result in personal injury or equipment damage.

Never attempt to make repairs to existing service valves. Unit operates under high pressure. Damaged seats and o-rings should not be replaced. Replacement of entire service valve is required. Service valve must be replaced by properly trained service technician.

Service valves provide a means for holding original factory charge in outdoor unit prior to hookup to indoor coil. They also contain gauge ports for measuring system pressures and provide shutoff convenience for certain types of repairs. (See Fig. 15.)

Front-seating service valves are used in outdoor residential equipment. This valve has a service port that contains a Schrader fitting. The service port is always pressurized after the valve is moved off the front-seat position.

The service valves used in the outdoor units come from the factory front-seated. This means that the refrigerant charge is isolated from the line-set connection ports. All heat pumps that are equipped with and AccuRater[®] piston heating metering device are shipped with an adapter stub tube. This tube must be installed on the liquid service valve. After connecting the stub tube to the liquid service valve of a heat pump, the valves are ready for brazing. The interconnecting tubing (line set) can be brazed to the service valves using industry accepted methods and materials. Consult local codes.

Before brazing the line set to the valves, the belled ends of the sweat connections on the service valves must be cleaned so that no brass plating remains on either the inside or outside of the bell joint. To prevent damage to the valve and/or cap “O” ring, use a wet cloth or other acceptable heat-sinking material on the valve before brazing. To prevent damage to the unit, use a metal barrier between brazing area and unit.

After the brazing operation and the refrigerant tubing and evaporator coil have been evacuated, the valve stem can be turned counterclockwise until back-seats, which releases refrigerant into tubing and evaporator coil. The system can now be operated.

Back-seating service valves must be back-seated (turned counterclockwise until seated) before the service-port caps can be removed and hoses of gauge manifold connected. In this position, refrigerant has access from and through outdoor and indoor unit.

The service valve-stem cap is tightened to 20 ± 2 ft/lb torque and the service-port caps to 9 ± 2 ft/lb torque. The seating surface of the valve stem has a knife-set edge against which the caps are tightened to attain a metal-to-metal seal. If accessory pressure switches are used, the service valve must be cracked. Then, the knife-set stem cap becomes the primary seal.

The service valve cannot be field repaired; therefore, only a complete valve or valve stem and service-port caps are available for replacement.

If the service valve is to be replaced, a metal barrier must be inserted between the valve and the unit to prevent damaging the unit exterior from the heat of the brazing operations.

! CAUTION

PERSONAL INJURY HAZARD

Failure to follow this caution may result in personal injury.

Wear safety glasses, protective clothing, and gloves when handling refrigerant.

Pumpdown Procedure

Service valves provide a convenient shutoff valve useful for certain refrigeration-system repairs. System may be pumped down to make repairs on low side without losing complete refrigerant charge.

1. Attach pressure gauge to suction service-valve gauge port.
2. Front seat liquid-line valve.
3. Start unit in cooling mode. Run until suction pressure reaches 5 psig (35kPa). Do not allow compressor to pump to a vacuum.
4. Shut unit off. Front seat suction valve.

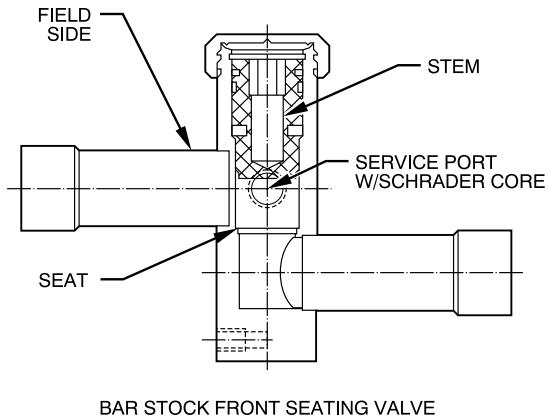

Fig. 15 – Suction Service Valve (Front Seating) Used in Base and Comfort ACs and HPs

A91447

NOTE: All outdoor unit coils will hold only factory-supplied amount of refrigerant. Excess refrigerant, such as in long-line applications, may

cause unit to relieve pressure through internal pressure-relief valve (indicated by sudden rise of suction pressure) before suction pressure reaches 5 psig (35kPa). If this occurs, shut unit off immediately, front seat suction valve, and recover remaining pressure.

Heating Piston (AccuRater®) - Heat Pumps Only

In most heat pumps, AccuRater pistons are used to meter refrigerant for heat pump heating mode only. All indoor coils are supplied with a bi-flow TXV for metering in the cooling mode. AccuRater piston has a refrigerant metering hole through it. The piston seats against the piston body in heating mode and meters the refrigerant in heating mode and allows refrigerant to flow around it in cooling mode.

There are 2 types of liquid line connections used. Flare connections are used in R-22 systems.

1. Shut off power to unit.
2. Pump unit down using pumpdown procedure described in this service manual.
3. Loosen nut and remove liquid line flare connection from AccuRater.
4. Pull retainer out of body, being careful not to scratch flare sealing surface. If retainer does not pull out easily, carefully use locking pliers to remove it.
5. Slide piston and piston ring out by inserting a small soft wire with small kinks through metering hole. Do not damage metering hole, sealing surface around piston cones, or fluted portion of piston.
6. Clean piston refrigerant metering hole.
7. Install a new retainer O-ring, retainer assembly, or Teflon washer before reassembling AccuRater.

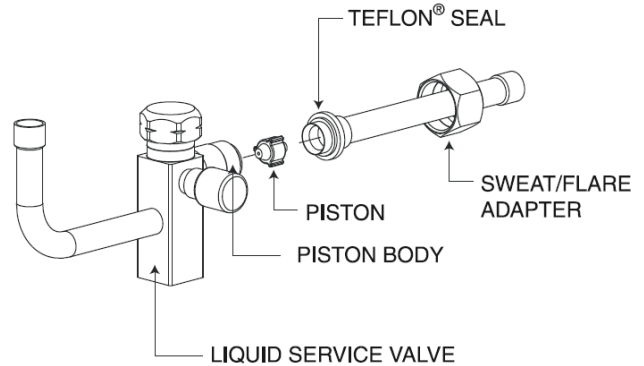

Fig. 16 – Front Seating Service Valve with Chatleff Connection Used in R-410A Heat Pumps.

A05226

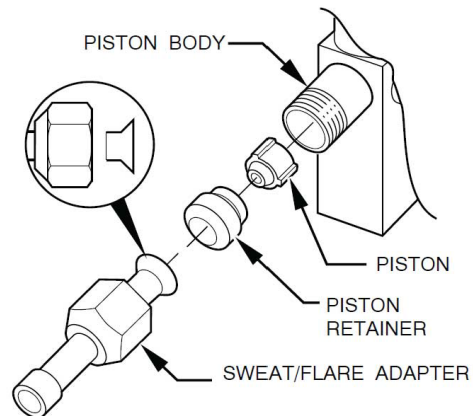

Fig. 17 – AccuRater Components (used in R-22 Heat Pumps)

A01019

NOTE: Some units have an OD TXV installed for heating expansion and do not require a piston. These units have a standard AC liquid service valve.

Reversing Valve

In heat pumps, changeover between heating and cooling modes is accomplished with a valve that reverses flow of refrigerant in between the two coils. This reversing valve device is easy to troubleshoot and replace. The reversing valve solenoid can be checked with power off with an ohmmeter. Check for continuity and shorting to ground. With control circuit (24v) power on, check for correct voltage at solenoid coil. Check for overheated solenoid.

With unit operating, other items can be checked, such as frost or condensate water on refrigerant lines.

The sound made by a reversing valve as it begins or ends defrost is a “whooshing” sound, as the valve reverses and pressures in system equalize. An experienced service technician detects this sound and uses it as a valuable troubleshooting tool.

Using a remote measuring device, check inlet and outlet line temperatures. DO NOT touch lines. If reversing valve is operating normally, inlet and outlet temperatures on appropriate lines should be close to each other. Any difference would be due to heat loss or gain across valve body. Temperatures are best checked with a remote reading electronic-type thermometer with multiple probes. Route thermocouple leads to inside of coil area through service valve mounting plate area underneath coil. Fig. 18 and Fig. 19 show test points (TP) on reversing valve for recording temperatures. Insulate points for more accurate reading.

If valve is defective:

1. Shut off all power to unit and remove charge from system.
2. Remove solenoid coil from valve body. Remove valve by cutting it from system with tubing cutter. Repair person should cut in such a way that stubs can be easily re-brazed back into system. Do not use hacksaw. This introduces chips into system that cause failure. After defective valve is removed, wrap it in wet rag and carefully unbrazed stubs. Save stubs for future use. Because defective valve is not overheated, it can be analyzed for cause of failure when it is returned.
3. Braze new valve onto used stubs. Keep stubs oriented correctly. Scratch corresponding matching marks on old valve and stubs and on new valve body to aid in lining up new valve properly. When brazing stubs into valve, protect valve body with wet rag to prevent overheating.
4. Use slip couplings to install new valve with stubs back into system. Even if stubs are long, wrap valve with a wet rag to prevent overheating.
5. After valve is brazed in, check for leaks. Evacuate and charge system. Check system in both modes several times for proper valve functions.

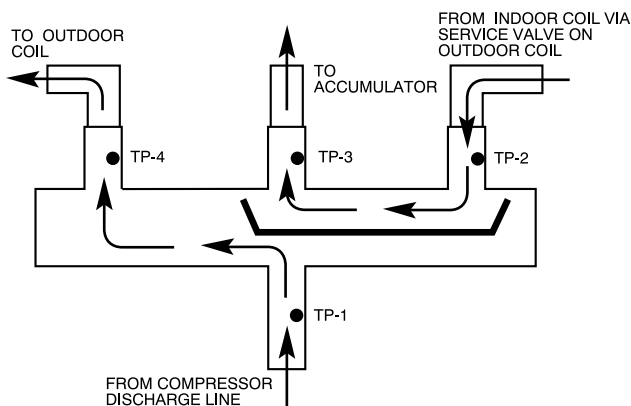

**Fig. 18 – Reversing Valve
(Cooling Mode or Defrost Mode, Solenoid Energized)**

A88342

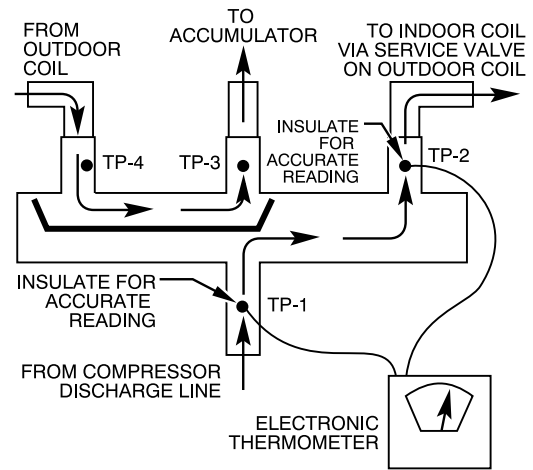

**Fig. 19 – Reversing Valve
(Heating Mode, Solenoid De-Energized)**

A88341

Liquid Line Filter Drier

Filter driers are specifically designed for R-22 or R-410A refrigerant. Only operate with the appropriate drier using factory authorized components.

It is recommended that the liquid line drier be installed at the indoor unit. Placing the drier near the TXV allows additional protection to the TXV as the liquid line drier also acts as a strainer.

Install Liquid-line Filter Drier Indoor - AC

! CAUTION

UNIT DAMAGE HAZARD

Failure to follow this caution may result in equipment damage or improper operation.

To avoid performance loss and compressor failure, installation of filter drier in liquid line is required.

! CAUTION

UNIT DAMAGE HAZARD

Failure to follow this caution may result in equipment damage or improper operation.

To avoid filter drier damage while brazing, filter drier must be wrapped in a heat-sinking material such as a wet cloth.

Refer to Fig. 20 and install filter drier as follows:

1. Braze 5-in. liquid tube to the indoor coil.
2. Wrap filter drier with damp cloth.
3. Braze filter drier to above 5” liquid tube. Flow arrow must point towards indoor coil.
4. Connect / braze liquid refrigerant tube to filter drier.

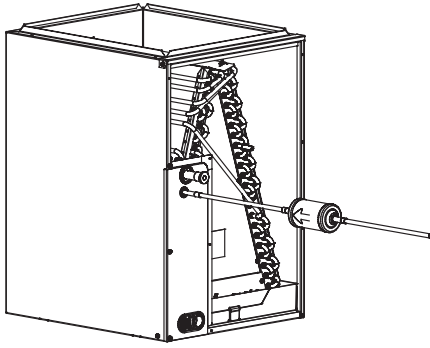

Fig. 20 – Liquid Line Filter Drier - AC

A05178

Install Liquid-line Filter Drier Indoor - HP

Refer to Fig. 21 and install filter drier as follows:

1. Braze 5 in. liquid tube to the indoor coil.
2. Wrap filter drier with damp cloth.
3. Braze filter drier to 5 in. long liquid tube from step 1.
4. Connect / braze liquid refrigerant tube to filter drier.

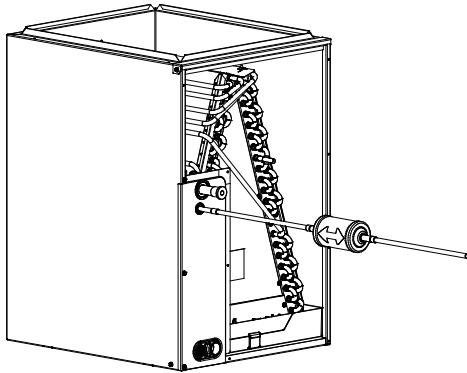

Fig. 21 – Liquid Line Filter Drier - HP

A05227

Suction Line Filter Drier

The suction line drier is specifically designed to operate with R-410A, use only factory authorized components. Suction line filter drier is used in cases where acid might occur, such as burnout. Heat pump units must have the drier installed between the compressor and accumulator only. Remove after 10 hours of operation. Never leave suction line filter drier in a system longer than 72 hours (actual time).

Accumulator

The accumulator is specifically designed to operate with R-410A or R-22 respectfully; use only factory-authorized components. Under some light load conditions on indoor coils, liquid refrigerant is present in suction gas returning to compressor. The accumulator stores liquid and allows it to boil off into a vapor so it can be safely returned to compressor. Since a compressor is designed to pump refrigerant in its gaseous state, introduction of liquid into it could cause severe damage or total failure of compressor.

The accumulator is a passive device which seldom needs replacing. Occasionally its internal oil return orifice or bleed hole may become plugged. Some oil is contained in refrigerant returning to compressor. It cannot boil off in accumulator with liquid refrigerant. The bleed hole allows a small amount of oil and refrigerant to enter the return line where velocity of refrigerant returns it to compressor. If bleed hole plugs, oil is trapped in accumulator, and compressor will eventually fail from lack of lubrication. If bleed hole is plugged, accumulator must be changed. The accumulator has a fusible element located in the bottom end bell. (See Fig. 22.) This fusible element will melt at 430°F//221°C and vent the refrigerant if this temperature is reached either internal or external to the system. If fuse melts, the accumulator must be replaced.

To change accumulator:

1. Shut off all power to unit.
2. Recover all refrigerant from system.
3. Break vacuum with dry nitrogen. Do not exceed 5 psig.

NOTE: Coil may be removed for access to accumulator. Refer to appropriate sections of Service Manual for instructions.

! CAUTION

PERSONAL INJURY HAZARD

Failure to follow this caution may result in personal injury.

Wear safety glasses, protective clothing, and gloves when handling refrigerant.

4. Remove accumulator from system with tubing cutter.
5. Tape ends of open tubing.
6. Scratch matching marks on tubing studs and old accumulator. Scratch matching marks on new accumulator. Unbraze stubs from old accumulator and braze into new accumulator.
7. Thoroughly rinse any flux residue from joints and paint with corrosion-resistant coating such as zinc-rich paint.
8. Install factory authorized accumulator into system with copper slip couplings.
9. Evacuate and charge system.

Pour and measure oil quantity (if any) from old accumulator. If more than 20 percent of oil charge is trapped in accumulator, add new POE oil to compressor to make up for this loss.

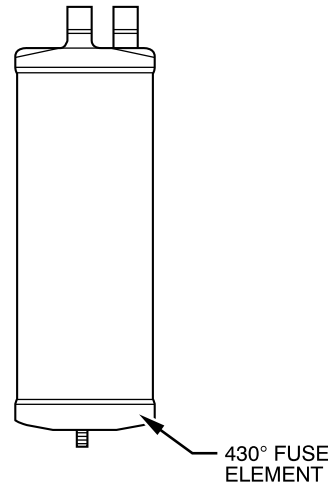

Fig. 22 – Accumulator

A88410

Thermostatic Expansion Valve (TXV)

All (post-2006) furnace coils, most fan coils, and a few heat pumps have a factory installed thermostatic expansion valve (TXV). The TXV will be a bi-flow, hard-shutoff with an external equalizer and a balance port pin. A hard shut-off TXV does not have a bleed port. Therefore, minimal equalization takes place after shutdown. TXVs are specifically designed to operate with R-410A or R-22 refrigerant, use only factory authorized TXV's. **Do not interchange R-410A and R-22 TXVs.**

TXV Operation

The TXV is a metering device that is used in air conditioning and heat pump systems to adjust to changing load conditions by maintaining a preset superheat temperature at the outlet of the evaporator coil. The volume of refrigerant metered through the valve seat is dependent upon the following:

1. Superheat temperature is sensed by cap tube sensing bulb on suction tube at outlet of evaporator coil. This temperature is converted into pressure by refrigerant in the bulb pushing downward on the diaphragm which opens the valve via the pushrod(s).
2. The suction pressure at the outlet of the evaporator coil is transferred via the external equalizer tube to the underside of the diaphragm. This is needed to account for the indoor coil pressure drop. Residential coils typically have a high pressure drop, which requires this valve feature.
3. The pin is spring loaded, which exerts pressure on the underside of the diaphragm. Therefore, the bulb pressure works against the spring pressure and evaporator suction pressure to open the valve. If the load increases, the temperature increases at the bulb, which increases the pressure on the top side of the diaphragm. This opens the valve and increases the flow of refrigerant. The increased refrigerant flow causes the leaving evaporator temperature to decrease. This lowers the pressure on the diaphragm and closes the pin. The refrigerant flow is effectively stabilized to the load demand with negligible change in superheat.

Install TXV

The thermostatic expansion valve is specifically designed to operate with a refrigerant type. Do not use an R-22 TXV on a R-410A system, and do not use a R-410A valve on an R-22 system. Refer to specification sheets for the appropriate TXV kit number.

CAUTION

UNIT OPERATION HAZARD

Failure to follow this caution may result in equipment damage or improper operation.

All indoor coil units must be installed with a hard shut off R-410A TXV metering device.

IMPORTANT: The TXV should be mounted as close to the indoor coil as possible and in a vertical, upright position. Avoid mounting the inlet tube vertically down. The valve is more susceptible to malfunction due to debris if inlet tube is facing down. A factory-approved filter drier must be installed in the liquid line at the indoor unit.

Installing TXV in Place of Piston in a Rated Indoor Coil (pre-2006)

1. Pump system down to 2 psig, if possible, and recover refrigerant.
2. Remove hex nut from piston body. Use backup wrench on fan coils.
3. Remove and discard factory-installed piston. Be sure Teflon seal is in place.
4. Reinstall hex nut. Finger tighten nut plus 1/2 turn.

NOTE: If the piston is not removed from the body, TXV will not function properly.

CAUTION

EQUIPMENT DAMAGE HAZARD

Failure to follow this caution may result in equipment damage or improper operation.

Use a brazing shield and wrap TXV with wet cloth or use heat sink material

5. Install TXV on indoor coil liquid line. Sweat swivel adapter to inlet of indoor coil and attach to TXV outlet. Use backup wrench to avoid damage to tubing or valve. Sweat inlet of TXV, marked "IN" to liquid line. Avoid excessive heat which could damage valve.
6. Install vapor elbow with equalizer adapter to suction tube of line set and suction connection to indoor coil. Adapter has a 1/4-in. male connector for attaching equalizer tube.
7. Connect equalizer tube of TXV to 1/4-in. equalizer fitting on vapor line adapter.
8. Attach TXV bulb to horizontal section of suction line using clamps provided. Insulate bulb with field-supplied insulation tape. See Fig. 23 for correct positioning of sensing bulb.
9. Proceed with remainder of unit installation.

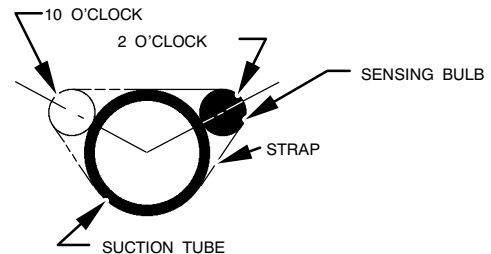

Fig. 23 – Position of Sensing Bulb

A08083

1. Pump system down to 2 psig, if possible, and recover refrigerant.
2. Remove coil access panel and fitting panel from front of cabinet.
3. Remove TXV support clamp using a 5/16-in. nut driver. Save the clamp.
4. Remove R-22 TXV using a backup wrench on flare connections to prevent damage to tubing.
5. Using wire cutters, cut equalizer tube off flush with vapor tube inside cabinet.
6. Remove bulb from vapor tube inside cabinet.
7. Braze equalizer stub-tube closed. Use protective barrier as necessary to prevent damage to drain pan.

IMPORTANT: Route the equalizer tube of TXV through suction line connection opening in fitting panel prior to replacing fitting panel around tubing.

8. Install TXV with 3/8-in. copper tubing through small hole in service panel. Use wrench and backup wrench, to avoid damage to tubing or valve, to attach TXV to distributor.
9. Reinstall TXV support clamp (removed in item 3).
10. Attach TXV bulb to vapor tube inside cabinet, in same location as original was when removed, using supplied bulb clamps (nylon or copper). See Fig. 23 for correct positioning of sensing bulb.
11. Route equalizer tube through suction connection opening (large hole) in fitting panel and install fitting panel in place.
12. Sweat inlet of TXV, marked "IN" to liquid line. Avoid excessive heat which could damage valve.
13. Install vapor elbow with equalizer adapter to vapor line of line set and vapor connection to indoor coil. Adapter has a 1/4-in. male connector for attaching equalizer tube.

14. Connect equalizer tube of TXV to 1/4-in. equalizer fitting on vapor line adapter. Use backup wrench to prevent damage to equalizer fitting.
15. Proceed with remainder of unit installation.

Replacing TXV on Indoor Coil (post-2006)

1. Pump system down to 2 psig, if possible, and recover refrigerant.
2. Remove coil access panel and fitting panel from front of cabinet.
3. Remove TXV support clamp using a 5/16-in. nut driver. Save the clamp (N coils only).
4. Remove TXV using a backup wrench on connections to prevent damage to tubing.
5. Remove equalizer tube from suction line of coil.
Note: Some coils may have a mechanical connection. If coil has a braze connection, use file or tubing cutter to cut brazed equalizer line approximately 2 inches above suction tube.
6. Remove bulb from vapor tube inside cabinet.
7. Install the new TXV using a wrench and backup wrench to avoid damage to tubing or valve to attach TXV to distributor.

Replacing TXV on an Indoor Coil (pre-2006)

8. Reinstall TXV support clamp (removed in item 3). (N coils only.)
9. Attach equalizer tube to suction line. If coil has mechanical connection, then use wrench and back up wrench to attach. If coil has brazed connection, use file or tubing cutters to remove mechanical flare nut from equalizer line. Then use coupling to braze the equalizer line to stub (previous equalizer line) in suction line.
10. Attach TXV bulb to vapor tube inside cabinet, in same location as original was when removed, using supplied bulb clamps (nylon or copper). See Fig. 23 for correct positioning of sensing bulb.
11. Route equalizer tube through suction connection opening (large hole) in fitting panel and install fitting panel in place.
12. Sweat inlet of TXV, marked "IN" to liquid line. Avoid excessive heat which could damage valve.
13. Proceed with remainder of unit installation.

Make Piping Connections

! WARNING

PERSONAL INJURY AND ENVIRONMENTAL HAZARD

Failure to follow this warning could result in personal injury or death. Relieve pressure and recover all refrigerant before system repair or final unit disposal. Use all service ports and open all flow-control devices, including solenoid valves.

! CAUTION

ELECTRICAL OPERATION HAZARD

Failure to follow this caution may result in equipment damage or improper operation. Do not leave system open to atmosphere any longer than minimum required for installation. POE oil in compressor is extremely susceptible to moisture absorption. Always keep ends of tubing sealed during installation.

! CAUTION

UNIT DAMAGE HAZARD

Failure to follow this caution may result in equipment damage or improper operation. If ANY refrigerant tubing is buried, provide a 6 in. vertical rise at service valve. Refrigerant tubing lengths up to 36 in. may be buried without further special consideration. Do not bury lines longer than 36 in.

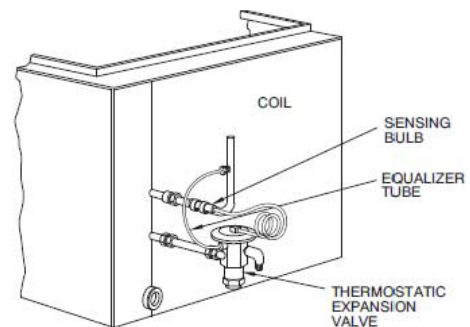

Fig. 24 – Typical TXV Installation

A91277

REFRIGERATION SYSTEM REPAIR

Leak Detection

New installations should be checked for leaks prior to complete charging. If a system has lost all or most of its charge, system must be pressurized again to approximately 150 psi minimum and 375 psi maximum. This can be done by adding refrigerant using normal charging procedures or by pressurizing system with nitrogen (less expensive than refrigerant). Nitrogen also leaks faster than refrigerants. Nitrogen cannot, however, be detected by an electronic leak detector. (See Fig. 25.)

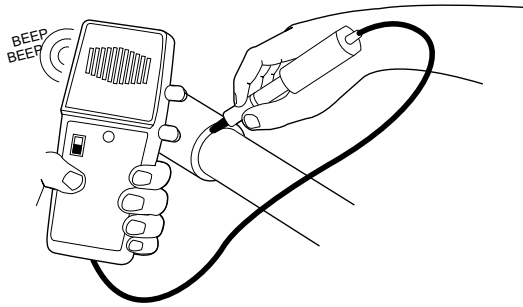

Fig. 25 – Electronic Leak Detection

A95422

! WARNING

PERSONAL INJURY AND UNIT DAMAGE HAZARD

Failure to follow this warning could result in personal injury or death. Due to the high pressure of nitrogen, it should never be used without a pressure regulator on the tank.

Assuming that a system is pressurized with either all refrigerant or a mixture of nitrogen and refrigerant, leaks in the system can be found with an electronic leak detector that is capable of detecting specific refrigerants.

If system has been operating for some time, first check for a leak visually. Since refrigerant carries a small quantity of oil, traces of oil at any joint or connection is an indication that refrigerant is leaking at that point.

A simple and inexpensive method of testing for leaks is to use soap bubbles. (See Fig. 26.) Any solution of water and soap may be used. Soap solution is applied to all joints and connections in system. A small pinhole leak is located by tracing bubbles in soap solution around leak. If the leak is very small, several minutes may pass before a bubble will form. Popular commercial leak detection solutions give better, longer-lasting bubbles and more accurate results than plain soapy water. The bubble solution must be removed from the tubing and fittings after checking for leaks as some solutions may corrode the metal.

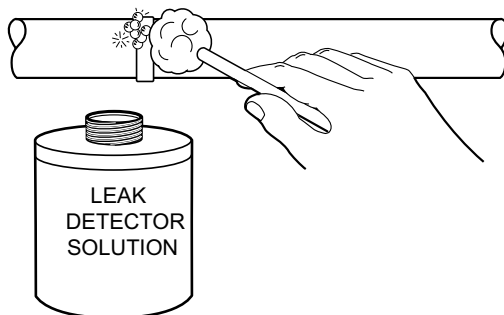

Fig. 26 – Bubble Leak Detection

A95423

You may use an electronic leak detector designed for specific refrigerant to check for leaks. (See Fig. 25.) This unquestionably is the most efficient and easiest method for checking leaks. There are various types

of electronic leak detectors. Check with manufacturer of equipment for suitability. Generally speaking, they are portable, lightweight, and consist of a box with several switches and a probe or sniffer. Detector is turned on and probe is passed around all fittings and connections in system. Leak is detected by either the movement of a pointer on detector dial, a buzzing sound, or a light.

In all instances when a leak is found, system charge must be recovered and leak repaired before final charging and operation. After leak testing or leak is repaired, replace liquid line filter drier, evacuate system, and recharge with correct refrigerant quantity.

Coil Removal

Coils are easy to remove if required for compressor removal, or to replace coil.

1. Shut off all power to unit.
2. Recover refrigerant from system through service valves.
3. Break vacuum with nitrogen.
4. Remove top cover. (See Remove Top Cover in Cabinet section of the manual.)
5. Remove screws in base pan to coil grille.
6. Remove coil grille from unit.
7. Remove screws on corner post holding coil tube sheet.

! WARNING

FIRE HAZARD

Failure to follow this warning could result in personal injury or equipment damage.

Cut tubing to reduce possibility of personal injury and fire.

8. Use a small tubing cutter to cut the liquid and vapor lines at both sides of coil. Cut in convenient location for easy reassembly with copper slip couplings.
9. Lift coil vertically from basepan and carefully place aside.
10. Reverse procedure to reinstall coil.
11. Replace filter drier, evacuate system, recharge, and check for normal systems operation.

Aluminum Coil Removal

For all aluminum coils, the coil has two or four (depending on the size of the unit) fin isolators on the top of the coil as shown in Fig. 27. These must be reinstalled onto the replacement coil.

! CAUTION

UNIT DAMAGE HAZARD

Failure to follow this caution may result in premature corrosion failure of the aluminum coil.

During coil replacement, when brazing the new coil into the unit, a guard is needed so copper-to-copper joint braze spatter does not reach any aluminum parts. This could cause pitting and premature failure due to corrosion.

Fabricate a metal braze shield of approximately 8" x 8" to protect aluminum components when brazing (Fig 28).

The orientation of the fin isolator is shown in Fig. 29. There is a threaded mechanical fitting on the liquid distributor. This connection is not field serviceable and should not be disturbed.

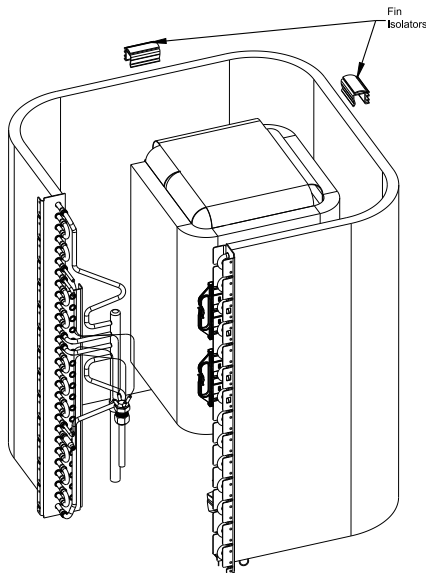

Fig. 27 – Fin Isolator Location

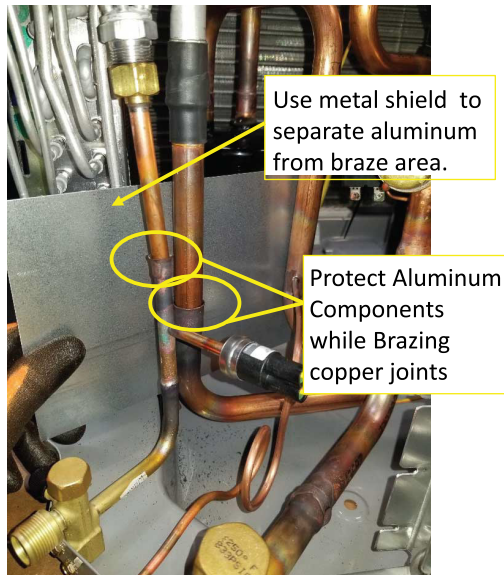
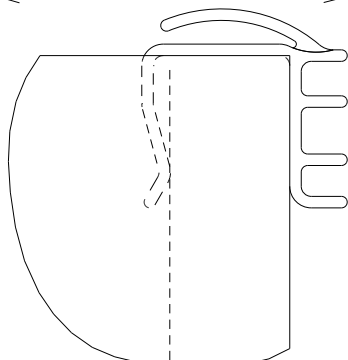

Fig. 28 – Use Braze Shield to Protect Aluminum

INSIDE OF UNIT ← → OUTSIDE OF UNIT



Orientation of Fin Isolator
Position Approx. in Middle of Coil
Typically 2 places mini & small base units
Typically 4 places med & large base units

Fig. 29 – Fin Isolator Orientation

The copper stub tube connection to the liquid service valve needs to be un-brazed for coil removal. (See Fig. 30.)

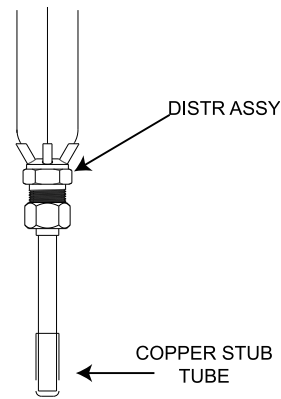

Fig. 30 – Copper Stub Tube Connection

A13188

Compressor Removal and Replacement
Once it is determined that compressor has failed and the reason established, compressor must be replaced.

A13187A

! CAUTION

PERSONAL INJURY HAZARD
Failure to follow this caution may result in personal injury.
Turn off all power to unit before proceeding. Wear safety glasses, protective clothing, and gloves when handling refrigerant. Acids formed as a result of motor burnout can cause burns.

! CAUTION

PERSONAL INJURY HAZARD
Failure to follow this caution may result in personal injury.
Wear safety glasses, protective clothing, and gloves when handling refrigerant and when using brazing torch.

1. Shut off all power to unit.
2. Remove and recover all refrigerant from system until pressure gauges read 0 psi. Use all service ports. Never open a system under a vacuum to atmosphere. Break vacuum with dry nitrogen holding charge first. Do not exceed 5 psig.
3. Disconnect electrical leads from compressor. Disconnect or remove crankcase heater and remove compressor hold-down bolts.
4. Cut compressor from system with tubing cutter. Do not use brazing torch for compressor removal. Oil vapor may ignite when compressor is disconnected.
5. Scratch matching marks on stubs in old compressor. Make corresponding marks on replacement compressor.
6. Use torch to remove stubs from old compressor and to reinstall them in replacement compressor.
7. Use copper couplings to tie compressor back into system.
8. Replace filter drier, evacuate system, recharge, and check for normal system operation.

A190396

A13186A

! CAUTION

UNIT DAMAGE HAZARD

Failure to follow this caution may result in equipment damage or improper operation.

Do not leave system open to atmosphere. Compressor oil is highly susceptible to moisture absorption.

System Clean-Up After Burnout

Some compressor electrical failures can cause motor to burn. When this occurs, by-products of burn, which include sludge, carbon, and acids, contaminate system. Test the oil for acidity using POE oil acid test to determine burnout severity. If burnout is severe enough, system must be cleaned before replacement compressor is installed. The 2 types of motor burnout are classified as mild or severe.

In mild burnout, there is little or no detectable odor. Compressor oil is clear or slightly discolored. An acid test of compressor oil will be negative. This type of failure is treated the same as mechanical failure. Liquid-line strainer should be removed and liquid-line filter drier replaced.

In a severe burnout, there is a strong, pungent, rotten egg odor. Compressor oil is very dark. Evidence of burning may be present in tubing connected to compressor. An acid test of compressor oil will be positive. Follow these additional steps:

1. TXV must be cleaned or replaced.
2. Drain any trapped oil from accumulator if used.
3. Remove and discard liquid-line strainer and filter drier.
4. After system is reassembled, install liquid and suction-line R-410A filter driers.

NOTE: On heat pumps, install suction line drier between compressor and accumulator.

5. Operate system for 10 hr. Monitor pressure drop across drier. If pressure drop exceeds 3 psig replace suction-line and liquid-line filter driers. Be sure to purge system with dry nitrogen when replacing filter driers. If suction line driers must be replaced, retest pressure drop after additional 10 hours (run time). Continue to monitor pressure drop across suction line filter drier. After 10 hr of run time, remove suction-line filter drier and replace liquid-line filter drier. Never leave suction-line filter drier in system longer than 72 hr (run time).
6. Charge system. (See unit information plate.)

! CAUTION

UNIT DAMAGE HAZARD

Failure to follow this caution may result in equipment damage or improper operation.

Only suction line filter driers should be used for refrigerant and oil clean up. Use of non-approved products could limit system life and void unit warranty.

Evacuation

Proper evacuation of the system will remove non-condensibles and assure a tight, dry system before charging. The two methods used to evacuate a system are the deep vacuum method and the triple evacuation method.

Deep Vacuum Method

The deep vacuum method requires a vacuum pump capable of pulling a vacuum of 500 microns and a vacuum gauge capable of accurately measuring this vacuum depth. The deep vacuum method is the most positive way of assuring a system is free of air and moisture. (See Fig. 31.)

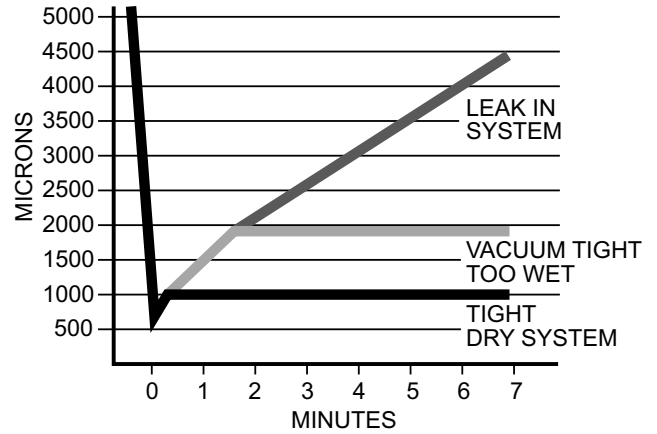

Fig. 31 – Deep Vacuum Graph

A95424

Triple Evacuation Method

The triple evacuation method should be used when vacuum pump is only capable of pumping down to 28 in. of mercury vacuum and system does not contain any liquid water. Refer to Fig. 32 and proceed as follows:

1. Pump system down to 28 in. of mercury and allow pump to continue operating for an additional 15 minutes.
2. Close service valves and shut off vacuum pump.
3. Connect a nitrogen cylinder and regulator to system and open until system pressure is 2 psig.
4. Close service valve and allow system to stand for 1 hr. During this time, dry nitrogen will be able to diffuse throughout the system absorbing moisture.
5. Repeat this procedure as indicated in Fig. 32. System will then be free of any contaminants and water vapor.

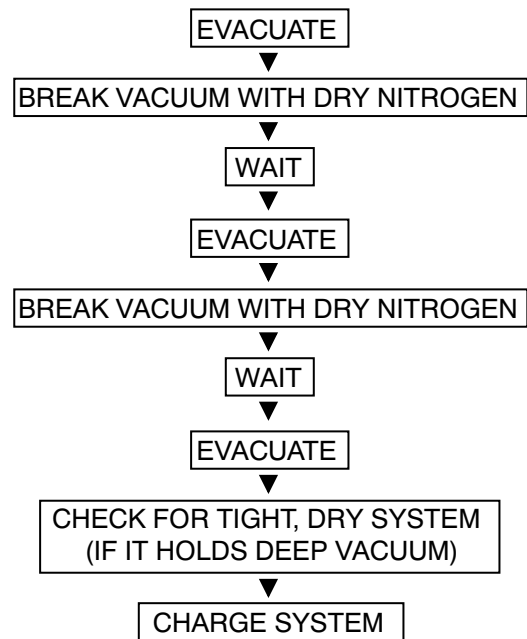

Fig. 32 – Triple Evacuation Method

A95425

Troubleshooting with SuperHeat

This troubleshooting routine was developed to diagnose cooling problems using superheat in TXV systems. It is effective on heat pumps in cooling mode as well as air conditioners. The system must utilize a TXV as the expansion device in cooling mode.

Basic Diagnostics

NOTE: When checking refrigerant charge and troubleshooting operating systems, the indoor airflow has significant effect on the determination. If you are at this stage, it is assumed you have already checked the subcooling once and believe the charge is correct. From this point, the airflow must be verified prior to proceeding, hence step 1 below.

1. Check or verify proper indoor airflow
 - Indoor air filter
 - Duct dampers and supply registers are open
 - Indoor coil for debris
2. Check subcooling at OD unit liquid service valve
 - Outdoor airflow (debris on coil, etc.)
 - Set the subcooling at value listed on rating plate if standard lineset
 - Set the subcooling at the maximum of 10°F or value listed on rating plate if a long line application
3. Check superheat at OD unit vapor service valve.
 - If low (< 2°F), proceed to Low SuperHeat section.
 - If between 2 and 20°F/11°C valve is probably operating properly.
 - If greater than 20°F/11°C, perform Pseudo Evaporator SuperHeat Instructions check as follows:
 - Check refrigerant pressure at vapor service valve and refrigerant temperature at outlet of evaporator.
 - Use suction line geometry (diameter and equivalent length), unit capacity and Tables 4 and 5 to determine suction pressure drop.
 - For standard lineset diameters (vapor service valve diameters and larger) and lengths (less than 80 ft), generally no pressure adjustment per Table 5 or Table 6) is required.
 - or longer (greater than 80 ft) and small diameter linesets (less than service valve size), correct pressure (add to gauge pressure reading) per Tables 5 and Table 6.
 - If Pseudo Superheat is greater than 15, proceed to High SuperHeat section.
 - If Pseudo Evaporator Superheat is between 2 and 15, TXV appears to be functioning properly.
 - If operation erratic (hunting), proceed to Hunting Superheat °F Superheat in repetition section.

NOTE: Hunting is when the valve superheat swings more than 10.

Low Superheat with Normal or Low Suction Pressure

NOTE: Normal or low suction pressure is considered for R-22: < 80 psig, R-410A: < 135 psig

1. Re-check airflow and then check sensing bulb tightness, orientation on vapor tube and is properly wrapped.
 - If OK proceed to Step 2
2. Check superheat at vapor service valve and Pseudo Evaporator Superheat.
 - If both are less than 2°F, TXV likely not controlling properly, i.e. stuck open -> REPLACE VALVE
 - If superheat is higher than 15°F, proceed to Step 3
3. Perform TXV function check.
 - With system running, place sensing bulb in ice bath for ~1 minute -> superheat should increase.
 - If no response, Replace Valve
 - If OK proceed to Step 4
4. Check for even temperature distribution at outlet of each circuit of evaporator

- If greater than 15°F between circuits, distributor or coil has a restriction.
- If OK proceed to Step 5

Low Superheat with High Suction Pressure

NOTE: High suction pressure is considered for R-22: > ~80 psig, R-410A: > ~135 psig. An application issue or other system component failure typically causes this condition.

5. R-22 Systems: Check that proper valve used (not an R-410A valve)
 - If OK proceed to Step 6
6. Check airflow, sensing bulb tightness, orientation on vapor tube and ensure bulb is properly wrapped.
 - If OK proceed to Step 7
7. Check that compressor is pumping properly

NOTE: Loose Rules of Thumb: Is discharge saturated ~20°F higher than ambient temperature? Is discharge superheat between 15 and 50?

- If OK proceed to Step 8
- 8. Recheck Airflow and Subcooling.
 - If OK proceed to Replace Valve

High Superheat with Normal or Low Pressure

NOTE: Normal or low suction pressure is considered: R-22 < 80 psig, R-410A < 135 psig.

9. Check for restriction in liquid line (kinked line, filter drier restricted, etc.)
 - If OK proceed to Step 10
10. Check for restriction in suction line (kink, restricted suction filter drier etc.)
 - If OK proceed to Step 11
11. Check power element cap tube is not broken
 - If OK proceed to Step 12
12. Check that equalizer tube is not kinked or plugged
 - If OK proceed to Step 13
13. Check that inlet screen (R-22 systems) is not restricted
 - If OK proceed to Step 14
14. Replace Valve

High Superheat with Normal or High Suction Pressure

NOTE: Normal to High suction pressure is considered for R-22: > ~65 psig, R-410A: > ~110 psig. An application issue or other system component failure typically causes this condition.

15. Check airflow, sensing bulb tightness, orientation on vapor tube and ensure bulb is properly wrapped.
 - If OK proceed to Step 16
16. R-410A Systems: Make sure proper valve is used (Not R-22)
 - If OK proceed to Step 17
17. Check for even temperature distribution at outlet of each circuit of evaporator
 - If OK proceed to Step 18
18. Check for high evaporator load: Return Air Leaks, high indoor wet bulb and/or dry bulb temp, undersized system, etc.
 - If OK proceed to Step 19
19. Check that compressor is pumping properly
- Loose Rule of Thumb: Is discharge saturated ~20°F higher than ambient temperature? Is discharge superheat between 15°F and 50°F?

Hunting Superheat

NOTE: Hunting is when the valve superheat swings more than 10°F Superheat in repetition. This is typically an application issue.

20. Check for obvious kinked or pinched distributor (capillary) tubes causing imbalance to the circuiting.
 - If OK proceed to Step 21
21. Check that proper size valve is used per Product Literature.
 - If OK proceed to Step 22
22. Check airflow, sensing bulb tightness, orientation on vapor tube and ensure bulb is properly wrapped.
 - If OK proceed to Step 23
23. Check for even temperature distribution ($\pm 5^\circ$ difference) at outlet of each circuit of evaporator and for even air distribution over all evaporator slabs.
 - If OK proceed to Step 24.
24. Move sensing bulb further down suction line.
 - If problem not corrected, replace valve

Pseudo Evaporator Superheat Instructions

The Pseudo Evaporator Superheat calculates the superheat at the outlet of the evaporator with known and available information. Because there generally is not a pressure port on the vapor line at the indoor coil, this procedure allows the service personnel to evaluate the evaporator superheat with the vapor pressure port at the outdoor unit.

The method requires the following information:

- Suction line temperature at the outlet of the evaporator (°F).

- Suction line pressure at the outdoor unit (psig).
- Outdoor nominal unit size (btuh).
- Suction line equivalent line length (ft).
- Suction line pressure drop from tables (Table 5 and Table 6).
- Pressure-Temperature relationship for refrigerant used (P-T Chart).

If system uses a vapor line the same size as vapor service valve fitting or larger AND the line set equivalent length is 80 feet or less, the pressure drop in vapor line of line set can be ignored.

1. Take suction line temperature at outlet of evaporator at indoor unit.
2. Take suction service valve pressure at OD unit.
3. Determine lineset vapor line equivalent length and tube diameter.
4. Determine suction line pressure drop from Table 5 (R-410A) or Table 6 (R-22).
5. Calculate Pseudo Evaporator Superheat.
 - Add the suction line pressure drop to the pressure reading obtained at suction service valve.

NOTE: For nominal and larger diameter vapor lines with standard length linesets (vapor line same size as service valve fitting size and larger with equivalent length less than 80 ft) the pressure drop can be ignored – use vapor service valve pressure and evaporator outlet temperature to calculate superheat

- Determine saturated evaporator temperature from a refrigerant pressure temperature relationship chart (PT chart).
- Subtract saturated evaporator from evaporator suction line temperature to obtain evaporator superheat.

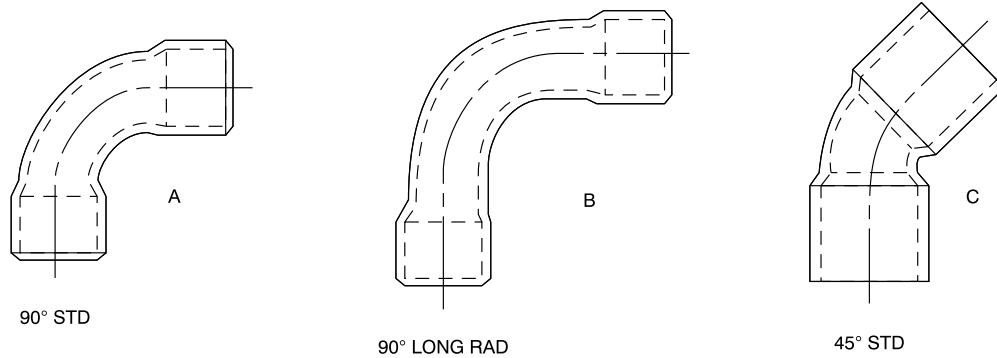

Fig. 33 – Tube Fitting Geometry
Table 4 – Fitting Losses in Equivalent Feet

A01058

TUBE SIZE OD (IN.)	90° STD (A)	90° LONG RAD (B)	45° STD (C)
1/2	1.2	0.8	0.6
5/8	1.6	1.0	0.8
3/4	1.8	1.2	0.9
7/8	2.0	1.4	1.0
1-1/8	2.6	1.7	1.3

Table 5 – R-410A System Suction Pressure Drop

Nominal Size (Btuh)	Suction Line OD (in.)	Pressure Drop (psi/100 ft)	Suction Velocity fpm	R-410A Suction Line Pressure Drop (psig)									
				Total Equivalent Line Length (ft)									
				20	80	50	100	125	150	175	200	225	
18000	1/2	9.9	1649	2	5	8	10	12	15	17	20	22	25
	5/8	3.1	1018	1	2	2	3	4	5	5	6		8
	3/4	1.2	678	0	1	1	1	1	2	2	2	3	3
24000	1/2	16.7	2199	3	8	13	17	21	25	29	33	38	42
	5/8	5.2	1357	1	3	4	5	7	8	9	10	12	13
	3/4	2.0	904	0	1	2	2	2	3	3	4	4	5
	7/8	1.0	678	0	0	1	1	1	1	2	2	2	2
30000	5/8	7.8	1696	2	4	6	8	10	12	14	16	18	20
	3/4	2.9	1130	1	1	2	3	4	4	5	6	7	7
	7/8	1.5	848	0	1	1	1	2	2	3	3	3	4
36000	5/8	10.9	2036	2	5	9	11	14	16	19	22	24	27
	3/4	4.1	1356	1	2	3	4	5	6	7	8	9	10
	7/8	2.0	1017	0	1	2	2	3	3	4	4	5	5
42000	5/8	14.1	2375	3	7	11	14	18	21	25	28	32	35
	3/4	5.4	1582	1	3	4	5	7	8	9	11	12	14
	7/8	2.7	1187	1	1	2	3	3	4	5	5	6	7
	1 1/8	0.8	696	0	0	1	1	1	1	1	2	2	2
48000	3/4	6.9	1808	1	3	6	7	9	10	12	14	16	17
	7/8	3.5	1357	1	2	3	3	4	5	6	7	8	9
	1 1/8	1.0	796	0	0	1	1	1	1	2	2	2	2
60000	3/4	10.4	2260	2	5	8	10	13	16	18	21	23	26
	7/8	5.2	1696	1	3	4	5	6	8	9	10	12	13
	1 1/8	1.4	995	0	1	1	1	2	2	3	3	3	3

■ = Line set application not recommended

Example 1

While on a service call, after checking for proper indoor and outdoor airflow, Tom finds the following pressures and temperatures at the service valves of a R-410A air conditioner:

- Liquid line pressure = 340 psig
- Liquid line temperature = 97°F
- Suction line pressure = 125 psig
- Suction line temperature = 70°F

Using a R-410A PT chart, the subcooling is determined to be 8°F, which is within ± 3 of the 10°F listed on the rating plate. Tom believes the charge is correct. He calculates the superheat to be approximately 27°F superheat. The apparently high superheat has Tom concerned.

Tom uses the Pseudo Evaporator Superheat method to check the TXV performance. The system is a 3-ton R-410A air conditioner with 75 feet equivalent length of 3/4" suction line. Based on Table 5, the system has approximately 3-psig pressure drop in the vapor line. Per the instructions, he takes the suction line temperature at the outlet of the evaporator and finds it to be 53°F. Tom adds 3 psig to the 125-psig suction pressure at the outdoor unit to get 128 psig evaporator pressure. The saturated pressure of 128 equates to 44°F. Tom calculates the evaporator superheat to be (53°F - 44°F =) 9°F. The TXV appears to be operating properly.

NOTE: The additional superheat at the compressor is due principally to heat gain in the 75 feet of suction line with a minor contribution by the pressure drop. Because the suction line of the lineset was the same size as the vapor service valve fitting and less than 80 feet, Tom could have ignored the pressure drop in the suction line and obtained the evaporator superheat by using the vapor service valve pressure of 125 psig (saturated temperature = 43°F) and the evaporator outlet temperature of 53°F. The evaporator superheat is calculated to be (53°F - 43°F =) 10 °F.

Table 6 – R-22 System Suction Pressure Drop

Nominal Size (Btuh)	Line OD (in.)	Pressure Drop (psi/100 ft)	Suction Velocity Fpm	R-22 Suction Line Pressure Drop (psig)									
				Total Equivalent Line Length (ft)									
				20	50	80	100	125	150	175	200	225	250
18000	5/8	13.6	2563	3	7	11	14	17	20	24	27	31	34
	5/8	4.0	1539	1	2	3	4	5	6	7	8	9	10
	3/4	1.5	1025	0	1	1	1	2	2	3	3	3	4
	7/8	0.8	769	0	0	1	1	1	1	1	2	2	2
24000	5/8	6.7	2052	1	3	5	7	8	10	12	13	15	17
	3/4	2.5	1367	1	1	2	3	3	4	4	5	6	6
	7/8	1.3	1026	0	1	1	1	2	2	2	3	3	3
30000	5/8	10.1	2565	2	5	8	10	13	15	18	20	23	25
	3/4	3.8	1708	1	2	3	4	5	6	7	8	9	9
	7/8	1.9	1282	0	1	2	2	2	3	3	4	4	5
36000	3/4	5.3	2050	1	3	4	5	7	8	9	11	12	13
	7/8	2.6	1538	1	1	2	3	3	4	5	5	6	7
	1 1/8	0.7	902	0	0	1	1	1	1	1	1	2	2
42000	3/4	7.0	2392	1	3	6	7	9	10	12	14	16	17
	7/8	3.5	1795	1	2	3	3	4	5	6	7	8	9
	1 1/8	1.0	1053	0	0	1	1	1	1	2	2	2	2
48000	3/4	8.9	2733	2	4	7	9	11	13	16	18	20	22
	7/8	4.4	2051	1	2	4	4	6	7	8	9	10	11
	1 1/8	1.2	1203	0	1	1	1	2	2	2	2	3	3
60000	7/8	6.7	2564	1	3	5	7	8	10	12	13	15	17
	1 1/8	1.8	1504	0	1	1	2	2	3	3	4	4	5
	1 3/8	0.7	987	0	0	1	1	1	1	1	1	2	2

☐ = Line set application not recommended

Example 2

Jason is servicing a 5-ton R-22 air conditioner with 7/8” suction line. As part of his basic inspection he believes he has normal airflow because the air filters are clean, ductwork appears to be properly sized and in good shape and the evaporator coil is clean. He then checks the superheat and subcooling at the outdoor unit service valves. Taking pressures and temperatures he finds the following:

- Liquid line pressure = 260 psig
- Liquid line temperature = 110°F
- Suction line pressure = 60 psig
- Suction line temperature = 65°F

Using an R-22 PT relationship, Jason calculates the subcooling to be approximately 10°F with 30°F superheat. Because the subcooling is correct but the superheat appears to be high, he is concerned and decides to perform the Pseudo Evaporator Superheat check.

Examining the lineset, Jason finds approximately 145 ft of suction line with 4 long radius elbows. Per Fig. 34 and Table 6, each fitting has an equivalent length of 1.4 ft. The total equivalent length of the suction line is $(145' + (4 * 1.4')) \approx 150$ ft. Based on Table 5, Jason determines there should be 10-psig pressure-drop in the suction line.

Jason now takes the suction line temperature at the outlet of the evaporator and obtains 51°F. Per the instructions, Jason adds the 10-psig pressure-drop to the 60-psig pressure at the outdoor unit to get 70-psig at the evaporator. Saturated pressure of 70-psig equates to approximately 41°F. Jason determines the Evaporator superheat to be $(51°F - 41°F =) 10°F$. Jason concludes the TXV is functioning properly.

NOTE: In this situation, both the pressure drop and the heat gain in the suction line are significant contributions to the superheat at the service valve. The pressure drop contributes approximately 7°F superheat and the heat gain in the suction line contributes 13°F.

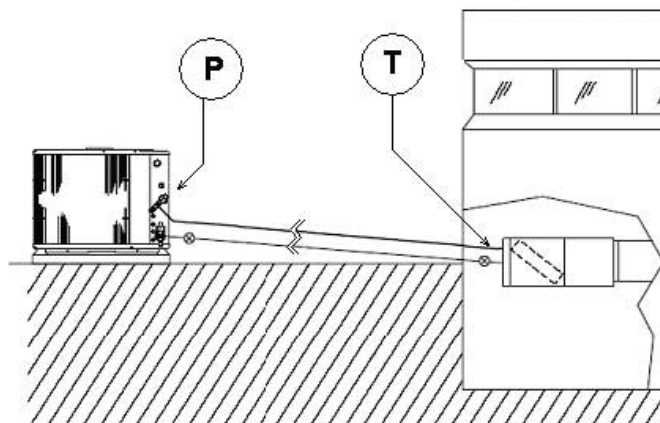

Fig. 34 – Pseudo Evaporator Superheat Pressure and Temperature Measurement Locations

Table 7 – R-410A Refrigerant Pressure Temperature Chart

PSIG	°F	PSIG	°F	PSIG	°F	PSIG	°F	PSIG	°F	PSIG	°F
12	-38.2	118	39.9	224	76.9	330	102.9	436	123.3	542	140.2
14	-35.3	120	40.8	226	77.4	332	103.3	438	123.6	544	140.5
16	-32.5	122	41.6	228	78.0	334	103.7	440	124.0	546	140.8
18	-29.9	124	42.5	230	78.5	336	104.1	442	124.3	548	141.1
20	-27.3	126	43.3	232	79.1	338	104.6	444	124.7	550	141.4
22	-24.9	128	44.2	234	78.7	340	105.0	446	125.0	554	141.9
24	-22.6	130	45.0	236	80.2	342	105.4	448	125.3	558	142.5
26	-20.4	132	45.8	238	80.7	344	105.8	450	125.7	560	142.8
28	-18.3	134	46.6	240	81.3	346	106.2	452	126.0	564	143.4
30	-16.2	136	47.5	242	81.8	348	106.6	454	126.4	568	143.9
32	-14.2	138	48.2	244	82.4	350	107.0	456	126.7	570	144.2
34	-12.3	140	49.0	246	82.9	352	107.5	458	127.0	574	144.8
36	-10.4	142	49.8	248	83.4	354	107.9	460	127.4	578	145.3
38	-8.6	144	50.6	250	83.9	356	108.3	462	127.7	580	145.6
40	-6.9	146	51.4	252	84.5	358	108.7	464	128.0	584	146.2
42	-5.1	148	52.1	254	85.0	360	109.1	466	128.4	588	146.7
44	-3.5	150	52.9	256	85.5	362	109.5	468	128.7	590	147.0
46	-1.9	152	53.6	258	86.0	364	109.9	4710	129.0	594	147.5
48	-0.3	154	54.4	260	86.5	366	110.3	472	129.4	598	148.1
50	1.3	156	55.1	262	87.0	368	110.7	474	129.7	600	148.4
52	2.8	158	55.8	264	87.5	370	111.1	476	130.0	604	148.9
54	4.2	160	56.5	268	88.0	372	111.5	478	130.3	606	149.2
56	5.7	162	57.3	268	88.5	374	111.9	480	130.7	608	149.4
58	7.1	164	58.0	270	89.0	376	112.2	482	131.0	610	151.3
60	8.5	166	58.7	272	89.5	378	112.6	484	131.3	612	150.0
62	9.8	168	59.4	274	60.0	380	113.0	486	131.6	614	150.2
64	11.1	170	60.1	278	90.5	382	113.4	488	131.9	616	150.5
66	12.4	172	60.7	278	91.0	384	113.8	490	132.3	618	150.7
68	13.7	174	61.4	280	91.5	386	114.2	492	132.6	620	151.0
70	15.0	176	62.1	282	92.0	388	114.6	494	132.9	624	151.5
72	16.2	178	62.8	284	92.4	390	114.9	496	133.2	626	151.8
74	17.4	180	63.4	286	92.9	392	115.3	498	133.5	628	152.1
76	18.6	182	64.1	288	93.4	394	115.7	500	133.8	630	152.3
78	19.8	184	64.7	290	93.9	396	116.1	502	134.1	634	152.8
80	20.9	186	65.4	292	94.3	398	116.4	504	134.5	636	153.1
82	22.0	188	66.0	294	94.8	400	116.8	506	134.8	638	153.3
84	23.2	190	66.7	296	95.3	402	117.2	508	135.1	640	153.6
86	24.3	192	67.3	298	95.7	404	117.5	510	135.4	644	154.1
88	25.3	194	67.9	300	96.2	406	117.9	512	135.7	646	154.3
90	26.4	196	68.6	302	96.7	408	118.3	514	136.0	648	154.6
92	27.4	198	69.2	304	97.1	410	118.6	516	136.3	650	154.8
94	28.5	200	69.8	306	97.6	412	119.0	518	136.6	654	161.8
96	29.5	202	70.4	308	98.0	414	119.4	520	136.9	656	155.6
98	30.5	204	71.0	310	98.5	416	119.7	522	137.2	658	155.8
100	31.5	206	71.6	312	98.9	418	120.1	524	137.5	660	158.3
102	32.5	208	72.2	314	99.4	420	120.5	526	137.8	664	156.6
104	33.4	210	72.8	316	99.8	422	120.8	528	138.1	666	156.8
106	34.4	212	73.4	318	100.2	424	121.2	530	138.4	668	157.1
108	35.3	214	74.0	320	100.7	426	121.5	532	138.7	670	157.3
110	36.3	216	74.6	322	101.1	428	121.9	534	139.0	574	157.7
112	37.2	218	75.1	324	101.6	430	122.2	536	139.3	676	158.0
114	38.1	220	75.7	326	102.0	432	122.6	536	139.6	Critical Point	
116	39.0	222	76.3	328	102.4	434	122.9	540	139.9	705	163.0

Table 8 – R-22 Refrigerant Pressure Temperature Relationship

PSIG	°F	PSIG	°F	PSIG	°F	PSIG	°F	PSIG	°F	PSIG	°F	PSIG	°F
7	-25.9	71	41.7	135	76.2	199	101.1	263	120.9	327	137.5	391	152.0
8	-24.0	72	42.3	136	76.7	200	101.4	264	121.1	328	137.8	392	152.2
9	-22.1	73	43.0	137	77.1	201	101.7	265	121.4	329	138.0	393	152.4
10	-20.4	74	43.7	138	77.6	202	102.1	266	121.7	330	138.2	394	152.6
11	-18.7	75	44.3	139	78.0	203	102.4	267	122.0	331	138.5	395	152.8
12	-17.0	76	45.0	140	78.4	204	102.8	268	122.3	332	138.7	396	153.1
13	-15.4	77	45.6	141	78.9	205	103.1	269	122.5	333	139.0	397	153.3
14	-13.8	78	46.2	142	79.3	206	103.4	270	122.8	334	139.2	398	153.5
15	-12.3	79	46.9	143	79.7	207	103.8	271	123.1	335	139.4	399	153.7
16	-10.8	80	47.5	144	80.2	208	104.1	272	123.4	336	139.7	400	153.9
17	-9.3	81	48.1	145	80.6	209	104.4	273	123.6	337	139.9	401	154.1
18	-7.9	82	48.7	146	81.0	210	104.8	274	123.9	338	140.2	402	154.3
19	-6.5	83	49.4	147	81.4	211	105.1	275	124.2	339	140.4	403	154.5
20	-5.2	84	50.0	148	81.8	212	105.4	276	124.5	340	140.6	404	154.7
21	-3.9	85	50.6	149	82.3	213	105.7	277	124.7	341	140.9	405	154.9
22	-1.6	86	51.2	150	82.7	214	106.1	278	125.0	342	141.1	406	155.1
23	-1.3	87	51.8	151	83.1	215	106.4	279	125.3	343	141.3	407	155.3
24	0.0	88	52.4	152	83.5	216	106.7	280	125.5	344	141.6	408	155.6
25	1.2	89	52.9	153	83.9	217	107.0	281	125.8	345	141.8	409	155.8
26	2.4	90	53.5	154	84.3	218	107.4	282	126.1	346	142.0	410	156.0
27	3.6	91	54.1	155	84.7	219	107.7	283	126.4	347	142.3	411	156.2
28	4.7	92	54.7	156	85.1	220	108.0	284	126.6	348	142.5	412	156.4
29	5.8	93	55.2	157	85.5	221	108.3	285	126.9	349	142.7	413	156.6
30	6.9	94	55.8	158	85.9	222	108.6	286	127.2	350	142.9	414	156.8
31	8.0	95	56.4	159	86.3	223	108.9	287	127.4	351	143.2	415	157.0
32	9.1	96	56.9	160	86.7	224	109.3	288	127.7	352	143.4	416	157.2
33	10.2	97	57.5	161	87.1	225	109.6	289	127.9	353	143.6	417	157.4
34	11.2	98	58.0	162	87.5	226	109.9	290	128.2	354	143.9	418	157.6
35	12.2	99	58.6	163	87.9	227	110.2	291	128.5	355	144.1	419	157.8
36	13.2	100	59.1	164	88.3	228	110.5	292	128.7	356	144.3	420	158.0
37	14.2	101	59.7	165	88.7	229	110.8	293	129.0	357	144.5	421	158.2
38	15.2	102	60.2	166	89.1	230	111.1	294	129.3	358	144.8	422	158.4
39	16.2	103	60.7	167	89.5	231	111.4	295	129.5	359	145.0	423	158.6
40	17.1	104	61.3	168	89.9	232	111.8	296	129.8	360	145.2	424	158.8
41	18.1	105	61.8	169	90.2	233	112.1	297	130.0	361	145.4	425	159.0
42	19.0	106	62.3	170	90.6	234	112.4	298	130.3	362	145.7	426	159.2
43	19.9	107	62.8	171	91.0	235	112.7	299	130.6	363	145.9	427	159.4
44	20.8	108	63.3	172	91.4	236	113.0	300	130.8	364	146.1	428	159.6
45	21.7	109	63.9	173	91.8	237	113.3	301	131.1	365	146.3	429	159.8
46	22.6	110	64.4	174	92.1	238	113.6	302	131.3	366	146.6	430	160.0
47	23.5	111	64.9	175	92.5	239	113.9	303	131.6	367	146.8	431	160.2
48	24.3	112	65.4	176	92.9	240	114.2	304	131.8	368	147.0	432	160.4
49	25.2	113	65.9	177	93.2	241	114.5	305	132.1	369	147.2	433	160.6
50	26.0	114	66.4	178	93.6	242	114.8	306	132.3	370	147.5	434	160.8
51	26.8	115	66.9	179	94.0	243	115.1	307	132.6	371	147.7	435	161.0
52	27.6	116	67.4	180	94.3	244	115.4	308	132.8	372	147.9	436	161.2
53	28.4	117	67.9	181	94.7	245	115.7	309	133.1	373	148.1	437	161.4
54	29.2	118	68.4	182	95.1	246	116.0	310	133.3	374	148.3	438	161.6
55	30.0	119	68.8	183	95.4	247	116.3	311	133.6	375	148.6	439	161.8
56	30.8	120	69.3	184	95.8	248	116.6	312	133.8	376	148.8	440	162.0
57	31.6	121	69.8	185	96.2	249	116.8	313	134.1	377	149.0	441	162.2
58	32.4	122	70.3	186	96.5	250	117.1	314	134.3	378	149.2	442	162.3
59	33.1	123	70.7	187	96.9	251	117.4	315	134.6	379	149.4	443	162.5
60	33.9	124	71.2	188	97.2	252	117.7	316	134.8	380	149.6	444	162.7
61	34.6	125	71.7	189	97.6	253	118.0	317	135.1	381	149.9	445	162.9
62	35.4	126	72.2	190	97.9	254	118.3	318	135.3	382	150.1	446	163.1
63	36.1	127	72.6	191	98.3	255	118.6	319	135.6	383	150.3	447	163.3
64	36.8	128	73.1	192	98.6	256	118.9	320	135.8	384	150.5	448	163.5
65	37.5	129	73.5	193	99.0	257	119.2	321	136.1	385	150.7	449	163.7
66	38.2	130	74.0	194	99.3	258	119.4	322	136.3	386	150.9	450	163.9
67	38.9	131	74.5	195	99.7	259	119.7	323	136.6	387	151.1		
68	39.6	132	74.9	196	100.0	260	120.0	324	136.8	388	151.4		
69	40.3	133	75.4	197	100.4	261	120.3	325	137.0	389	151.6		
70	41.0	134	75.8	198	100.7	262	120.6	326	137.3	390	151.8		
												Critical	
												709	205.1

Table 9 – Puron Subcooling Chart

Liq Press PSIG	P-T (°F)	Liquid Line Temperature (°F)									
		Subcooling (°F)									
		2	4	6	8	10	12	14	16	18	20
200	70	68	66	64	62	60	58	56	54	52	50
210	73	71	69	67	65	63	61	59	57	55	53
220	76	74	72	70	68	66	64	62	60	58	56
230	79	77	75	73	71	69	67	65	63	61	59
240	82	80	78	76	74	72	70	68	66	64	62
250	84	82	80	78	76	74	72	70	68	66	64
260	87	85	83	81	79	77	75	73	71	69	67
270	89	87	85	83	81	79	77	75	73	71	69
280	92	90	88	86	84	82	80	78	76	74	72
290	94	92	90	88	86	84	82	80	78	76	74
300	96	94	92	90	88	86	84	82	80	78	76
310	99	97	95	93	91	89	87	85	83	81	79
320	101	99	97	95	93	91	89	87	85	83	81
330	103	101	99	97	95	93	91	89	87	85	83
340	105	103	101	99	97	95	93	91	89	87	85
350	107	105	103	101	99	97	95	93	91	89	87
360	109	107	105	103	101	99	97	95	93	91	89
370	111	109	107	105	103	101	99	97	95	93	91
380	113	111	109	107	105	103	101	99	97	95	93
390	115	113	111	109	107	105	103	101	99	97	95
400	117	115	113	111	109	107	105	103	101	99	97
410	119	117	115	113	111	109	107	105	103	101	99
420	121	119	117	115	113	111	109	107	105	103	101
430	122	120	118	116	114	112	110	108	106	104	102
440	124	122	120	118	116	114	112	110	108	106	104
450	125	124	122	120	118	116	114	112	110	108	106
460	127	125	123	121	119	117	115	113	111	109	107
470	129	127	125	123	121	119	117	115	113	111	109
480	131	129	127	125	123	121	119	117	115	113	111
490	132	130	128	126	124	122	120	118	116	114	112
500	134	132	130	128	126	124	122	120	118	116	114
510	135	133	131	129	127	125	123	121	119	117	115
520	137	135	133	131	129	127	125	123	121	119	117
530	139	137	135	133	131	129	127	125	123	121	119
540	140	138	136	134	132	130	128	126	124	122	120
550	141	139	137	135	133	131	129	127	125	123	121
560	143	141	139	137	135	133	131	129	127	125	123
570	144	142	140	138	136	134	132	130	128	126	124
580	146	144	142	140	138	136	134	132	130	128	126
590	147	145	143	141	139	137	135	133	131	129	127
600	149	147	145	143	141	139	137	135	133	131	129
610	150	148	146	144	142	140	138	136	134	132	130

Table 10 – R-410A Superheat Chart

Vap Press (PSIG)	P - T (°F)	Vapor Line Temperature (°F)														
		Superheat (°F)														
		2	4	6	8	10	12	14	16	18	20	22	24	26	28	30
80	21	23	25	27	29	31	33	35	37	39	41	43	45	47	49	51
82	22	24	26	28	30	32	34	36	38	40	42	44	46	48	50	52
84	23	25	27	29	31	33	35	37	39	41	43	45	47	49	51	53
86	24	26	28	30	32	34	36	38	40	42	44	46	48	50	52	54
88	25	27	29	31	33	35	37	39	41	43	45	47	49	51	53	55
90	26	28	30	32	34	36	38	40	42	44	46	48	50	52	54	56
92	27	29	31	33	35	37	39	41	43	45	47	49	51	53	55	57
94	28	31	33	35	37	39	41	43	45	47	49	51	53	55	57	59
96	29	32	34	36	38	40	42	44	46	48	50	52	54	56	58	60
98	30	33	35	37	39	41	43	45	47	49	51	53	55	57	59	61
100	31	34	36	38	40	42	44	46	48	50	52	54	56	58	60	62
102	32	35	37	39	41	43	45	47	49	51	53	55	57	59	61	63
104	33	36	38	40	42	44	46	48	50	52	54	56	58	60	62	64
106	34	37	39	41	43	45	47	49	51	53	55	57	59	61	63	65
108	35	37	39	41	43	45	47	49	51	53	55	57	59	61	63	65
110	36	38	40	42	44	46	48	50	52	54	56	58	60	62	64	66
112	37	39	41	43	45	47	49	51	53	55	57	59	61	63	65	67
114	38	40	42	44	46	48	50	52	54	56	58	60	62	64	66	68
116	39	41	43	45	47	49	51	53	55	57	59	61	63	65	67	69
118	40	42	44	46	48	50	52	54	56	58	60	62	64	66	68	70
120	41	43	45	47	49	51	53	55	57	59	61	63	65	67	69	71
122	42	44	46	48	50	52	54	56	58	60	62	64	66	68	70	72
124	43	45	47	49	51	53	55	57	59	61	63	65	67	69	71	73
126	44	46	48	50	52	54	56	58	60	62	64	66	68	70	72	74
128	44	46	48	50	52	54	56	58	60	62	64	66	68	70	72	74
130	45	47	49	51	53	55	57	59	61	63	65	67	69	71	73	75
132	46	48	50	52	54	56	58	60	62	64	66	68	70	72	74	76
134	47	49	51	53	55	57	59	61	63	65	67	69	71	73	75	77
136	48	50	52	54	56	58	60	62	64	66	68	70	72	74	76	78
138	48	50	52	54	56	58	60	62	64	66	68	70	72	74	76	78
140	49	51	53	55	57	59	61	63	65	67	69	71	73	75	77	79
142	50	52	54	56	58	60	62	64	66	68	70	72	74	76	78	80
144	51	53	55	57	59	61	63	65	67	69	71	73	75	77	79	81
146	52	54	56	58	60	62	64	66	68	70	72	74	76	78	80	82
148	52	54	56	58	60	62	64	66	68	70	72	74	76	78	80	82
150	53	55	57	59	61	63	65	67	69	71	73	75	77	79	81	83
152	54	56	58	60	62	64	66	68	70	72	74	76	78	80	82	84
154	55	57	59	61	63	65	67	69	71	73	75	77	79	81	83	85
156	55	57	59	61	63	65	67	69	71	73	75	77	79	81	83	85
158	56	58	60	62	64	66	68	70	72	74	76	78	80	82	84	86
160	57	59	61	63	65	67	69	71	73	75	77	79	81	83	85	87
162	58	60	62	64	66	68	70	72	74	76	78	80	82	84	86	88

Table 11 – R-22 Subcooling Chart

Liquid Press (PSIG)	P-T (°F)	R-22 Liquid Line Temperature (°F)												
		Subcooling (°F)												
		2	4	6	8	10	12	14	16	18	20	22	24	26
120	70	68	66	64	62	60	58	56	54	52	50	48	46	44
125	72	70	68	66	64	62	60	58	56	54	52	50	48	46
130	74	72	70	68	66	64	62	60	58	56	54	52	50	48
135	76	74	72	70	68	66	64	62	60	58	56	54	52	50
140	79	77	75	73	71	69	67	65	63	61	59	57	55	53
145	81	79	77	75	73	71	69	67	65	63	61	59	57	55
150	83	81	79	77	75	73	71	69	67	65	63	61	59	57
155	85	83	81	79	77	75	73	71	69	67	65	63	61	59
160	87	85	83	81	79	77	75	73	71	69	67	65	63	61
165	89	87	85	83	81	79	77	75	73	71	69	67	65	63
170	91	89	87	85	83	81	79	77	75	73	71	69	67	65
175	93	91	89	87	85	83	81	79	77	75	73	71	69	67
180	95	93	91	89	87	85	83	81	79	77	75	73	71	69
185	96	94	92	90	88	86	84	82	80	78	76	74	72	70
190	98	96	94	92	90	88	86	84	82	80	78	76	74	72
195	100	98	96	94	92	90	88	86	84	82	80	78	76	74
200	102	100	98	96	94	92	90	88	86	84	82	80	78	76
205	103	101	99	97	95	93	91	89	87	85	83	81	79	77
210	105	103	101	99	97	95	93	91	89	87	85	83	81	79
215	107	105	103	101	99	97	95	93	91	89	87	85	83	81
220	108	106	104	102	100	98	96	94	92	90	88	86	84	82
225	110	108	106	104	102	100	98	96	94	92	90	88	86	84
230	111	109	107	105	103	101	99	97	95	93	91	89	87	85
235	113	111	109	107	105	103	101	99	97	95	93	91	89	87
240	114	112	110	108	106	104	102	100	98	96	94	92	90	88
245	116	114	112	110	108	106	104	102	100	98	96	94	92	90
250	117	115	113	111	109	107	105	103	101	99	97	95	93	91
255	119	117	115	113	111	109	107	105	103	101	99	97	95	93
260	120	118	116	114	112	110	108	106	104	102	100	98	96	94
265	121	119	117	115	113	111	109	107	105	103	101	99	97	95
270	123	121	119	117	115	113	111	109	107	105	103	101	99	97
275	124	122	120	118	116	114	112	110	108	106	104	102	100	98
280	126	124	122	120	118	116	114	112	110	108	106	104	102	100
285	127	125	123	121	119	117	115	113	111	109	107	105	103	101
290	128	126	124	122	120	118	116	114	112	110	108	106	104	102
295	129	127	125	123	121	119	117	115	113	111	109	107	105	103
300	131	129	127	125	123	121	119	117	115	113	111	109	107	105
305	132	130	128	126	124	122	120	118	116	114	112	110	108	106
310	133	131	129	127	125	123	121	119	117	115	113	111	109	107
315	135	133	131	129	127	125	123	121	119	117	115	113	111	109
320	136	134	132	130	128	126	124	122	120	118	116	114	112	110
325	137	135	133	131	129	127	125	123	121	119	117	115	113	111
330	138	136	134	132	130	129	126	124	122	120	118	116	114	112

Table 12 – R-22 Superheat Chart

		R-22 Vapor Line Temperature (°F)														
Vap Press (PSIG)	P - T (°F)	Superheat (°F)														
		2	4	6	8	10	12	14	16	18	20	22	24	26	28	30
50	26	28	30	32	34	36	38	40	42	44	46	48	50	52	54	56
51	27	29	31	33	35	37	39	41	43	45	47	49	51	53	55	57
52	28	30	32	34	36	38	40	42	44	46	48	50	52	54	56	58
53	28	30	32	34	36	38	40	42	44	46	48	50	52	54	56	58
54	29	31	33	35	37	39	41	43	45	47	49	51	53	56	57	59
55	30	32	34	36	38	40	42	44	46	48	50	52	54	56	58	60
56	31	33	35	37	39	41	43	45	47	49	51	53	55	57	59	61
57	32	34	36	38	40	42	44	46	48	50	52	54	56	58	60	62
58	32	34	36	38	40	42	44	46	48	50	52	54	56	58	60	62
59	33	35	37	39	41	43	45	47	49	51	53	55	57	59	61	63
60	34	36	38	40	42	44	46	48	50	52	54	56	58	60	62	64
61	35	37	39	41	43	45	47	49	51	53	55	57	59	61	63	65
62	35	37	39	41	43	45	47	49	51	53	55	57	59	61	63	65
63	36	38	40	42	44	46	48	50	52	54	56	58	60	62	64	66
64	37	39	41	43	45	47	49	51	53	55	57	59	61	63	65	67
65	38	40	42	44	46	48	50	52	54	56	58	60	62	64	66	68
66	38	40	42	44	46	48	50	52	54	56	58	60	62	64	66	68
67	39	41	43	45	47	49	51	53	55	57	59	61	63	65	67	69
68	40	42	44	46	48	50	52	54	56	58	60	62	64	66	68	70
69	40	42	44	46	48	50	52	54	56	58	60	62	64	66	68	70
70	41	43	45	47	49	51	53	55	57	59	61	63	65	67	69	71
71	42	44	46	48	50	52	54	56	58	60	62	64	66	68	70	72
72	42	44	46	48	50	52	54	56	58	60	62	64	66	68	70	72
73	43	45	47	49	51	53	55	57	59	61	63	65	67	69	71	73
74	44	46	48	50	52	54	56	58	60	62	64	66	68	70	72	74
75	44	46	48	50	52	54	56	58	60	62	64	66	68	70	72	74
76	45	47	49	51	53	55	57	59	61	63	65	67	69	71	73	75
77	46	48	50	52	54	56	58	60	62	64	66	68	70	72	74	76
78	46	48	50	52	54	56	58	60	62	64	66	68	70	72	74	76
79	47	49	51	53	55	57	59	61	63	65	67	69	71	73	75	77
80	48	50	52	54	56	58	60	62	64	66	68	70	72	74	76	78
81	48	50	52	54	56	58	60	62	64	66	68	70	72	74	76	78
82	49	51	53	55	57	59	61	63	65	67	69	71	73	75	77	79
83	50	52	54	56	58	60	62	64	66	68	70	72	74	76	78	80
84	50	52	54	56	58	60	62	64	66	68	70	72	74	76	78	80
85	51	53	55	57	59	61	63	65	67	69	71	73	75	77	79	81
86	51	53	55	57	59	61	63	65	67	69	71	73	75	77	79	81
87	52	54	56	58	60	62	64	66	68	70	72	74	76	78	80	82
88	53	55	57	59	61	63	65	67	69	71	73	75	77	79	81	83
89	53	55	57	59	61	63	65	67	69	71	73	75	77	79	81	83
90	54	56	58	60	62	64	66	68	70	72	74	76	78	80	82	84
91	54	56	58	60	62	64	66	68	70	72	74	76	78	80	82	84
92	55	57	59	61	63	65	67	69	71	73	75	77	79	81	83	85

Two Stage Non-communicating N4A7/N4H6

These units are non-communicating and utilize 2-stage scroll technology. These units require variable speed furnaces that are compatible with two-stage operation (such as F/G8MVL) or newer model variable speed fan coils (FVM4X). Variable speed fan coils prior to the FVM4X will NOT be rated with the new Performance series two-stage units as they are not capable of meeting the air flow requirements necessary for rating. These are designed to operate with basic 24 volt thermostat inputs.

Operating Ambient

The minimum outdoor operating ambient in cooling mode is 55°F/ 12.78°C, and the maximum outdoor operating ambient in cooling mode is 125°F / 51.67°C when operating voltage is 230v. For 208v applications, the maximum outdoor ambient is 120°F / 48.9°C.

NOTE: Units operating at high stage operation, 208v (or below) line voltage and at an outdoor ambient of 120°F (or greater), may experience compressor trip.

NOTE: This product is not approved for low ambient cooling at this time, and no low ambient kit is available.

Airflow Selections (ECM Furnaces)

The ECM Furnaces provide blower operation to match the capacities of the compressor during high and low stage cooling operation. Tap selections on the furnace control board enable the installing technician to select the proper airflows for each stage of cooling. Below is a brief summary of the furnace airflow configurations

1. The Y2 call for high stage cooling energizes the “Cool” tap on the control board. The grey wire from cool tap is connected to tap 5 on the motor. Refer to the furnace Product Data to find the corresponding airflow. If the airflow setting for high cooling needs to be switched from tap 5 to a different tap, jumper a connection from the cool tap to the desired tap so that the Y2 signal is communicated via the cool tap to the desired speed tap.
2. The Y1 call for low stage cooling energizes the “Fan” tap on the control board. The red wire from the fan tap is connected to tap 1 on the motor. Refer to the furnace Product Data to find the corresponding airflow. If the airflow setting for low cooling needs to be switched from tap 1 to a different tap, jumper a connection from the Fan tap to the desired tap so that the Y1 signal is communicated via the Fan tap to the desired speed tap. The Y1 setting will also govern the continuous fan airflow for the furnace.

Refer to the literature for the furnace for further details.

Airflow Selection for Variable Speed Furnaces (non-communicating)

The variable speed furnaces provide blower operation to match the capacities of the compressor during high and low stage cooling operation. The furnace control board allows the installing technician to select the proper airflows for each stage of cooling. Below is a summary of required adjustments. See furnace installation instructions for more details:

1. Turn SW1-5 ON for 400 CFM/ton airflow or OFF for 350 CFM/ton airflow. Factory default is OFF.
2. The A/C DIP switch setting determines airflow during high stage cooling operation. Select the A/C DIP switch setting corresponding to the available airflow shown in the furnace Installation Instructions that most closely matches the required airflow shown in the air conditioning Product Data for HIGH speed.
3. The CF DIP switch setting determines airflow during low stage cooling operation. Select the CF DIP switch setting corresponding to the available airflow shown in the furnace installation instructions that most closely matches the required airflow shown

in the air conditioning Product Data for LOW speed. If a higher or lower continuous fan speed is desired, the continuous fan speed can be changed using the fan switch on the thermostat. Refer to the furnace Installation Instructions for details of how to use this feature.

Airflow Selection for FVM4X Fan Coils (non-communicating)

The FVM4X provides high and low-stage blower operation to match the capacities of the compressor at high and low-stage.

To select recommended airflow, refer to the FVM4X Installation Instructions. The FVM4X utilizes an Easy Select control board that allows the installing technician to select proper airflows. This fan coil has an adjustable blower-off delay factory set at 90 sec. for high- and low-stage blower operation.

System function and Sequence Of Operation (N4A7/N4H6)

NOTE: Defrost control board is equipped with 5 minute lockout timer that is initiated upon any interruption of power.

Turn on power to indoor and outdoor units. Transformer is energized.

These models utilize a 2-stage indoor thermostat. With a call for first (low) stage cooling or heating, the outdoor fan and low-stage compressor are energized. If low-stage cannot satisfy cooling or heating demand, high-stage is energized by the second (high) stage of the indoor thermostat. After the second stage is satisfied, the unit returns to low-stage operation until second stage is required again. When both, first and second stage cooling or heating are satisfied, the compressor will shut off.

Cooling

With first stage cooling, Y and O are powered on; and with second stage cooling, Y2, Y and O are powered on. The O energizes the reversing valve, switching it to cooling position. The Y signal sends low voltage through the safeties and energizes the T1 terminal on the circuit board. If the compressor has been off for 5 minutes, or power has not been cycled for 5 minutes, the OF2 relay and T2 terminal will energize. This will close the contactor and start the outdoor fan motor and compressor. When the cycle is complete, Y is turned off, stopping the compressor and outdoor fan. The 5 minute time guard begins counting. Compressor will not come on until this delay expires. In the event of a power interruption, the time guard will not allow another cycle for 5 minutes.

Heating

With first stage heating, Y is powered on; with second stage heating, Y2 and Y are powered on. The Y signal sends low voltage through the safeties and energizes the T1 terminal on the circuit board. If the compressor has been off for 5 minutes or power has not been cycled for 5 minutes, the OF2 relay and T2 terminal will energize. This will close the contactor and start the outdoor fan motor and compressor.

When the cycle is complete, Y is turned off, stopping the compressor and outdoor fan. The 5 minute time guard begins counting. Compressor will not come on until this delay expires. In the event of a power interruption, the time guard will not allow another cycle for 5 minutes.

Compressor Operation

The basic scroll design has been modified with the addition of an internal unloading mechanism that opens a by-pass port in the first compression pocket, effectively reducing the displacement of the scroll. The opening and closing of the by-pass port is controlled by an internal electrically operated solenoid. The modulated scroll uses a single step of unloading to go from full capacity to approximately 67% capacity.

A single speed, high efficiency motor continues to run while the scroll modulates between the two capacity steps. Modulation is achieved by venting a portion of the gas in the first suction pocket back to the low

side of the compressor, thereby reducing the effective displacement of the compressor.

Full capacity is achieved by blocking these ports, thus increasing the displacement to 100%. A DC solenoid in the compressor controlled by a rectified 24 volt AC signal in the external solenoid plug moves the slider ring that covers and uncovers these ports.

The port covers are arranged in such a manner that the compressor operates at approximately 67% capacity when the solenoid is not energized and 100% capacity when the solenoid is energized. The loading and unloading of the two step scroll is done "on the fly" without shutting off the motor between steps.

NOTE: 67% compressor capacity translates to approximately 75% cooling or heating capacity at the indoor coil.

The compressor will always start unloaded and stay unloaded for five seconds even when the thermostat is calling for high stage capacity.

Quiet Shift

Quiet shift is a field selectable defrost mode (factory set to OFF), which will eliminate occasional noise that could be heard at the start of defrost cycle and restarting of heating cycle. It is selected by placing DIP switch 3 on defrost board (see Fig. 35) in the ON position.

When Quiet Shift switch is placed in ON position, and a defrost is initiated, the following sequence of operation will occur. Reversing valve will energize, compressor will turn off for 30 seconds, and then turn back on to complete defrost. At the start of heating after conclusion of defrost, reversing valve will de-energize, compressor will turn off for another 30 seconds, and the fan will turn off for 40 seconds, before starting in the heating mode.

FAST# 1185790 Defrost Control

This defrost control is used in some non-communicating heat pumps and has all the same functionality, speedups, and troubleshooting as the FAST# 1174185 except for the forced defrost timing when Quiet Shift-2 is enabled.

Quiet Shift-2 (non-communicating)

Quiet shift-2 is a field selectable defrost mode (factory set to OFF), which will reduce the occasional noise that could be heard at the start of defrost cycle and restarting of heating cycle. It is selected by placing DIP switch 3 on defrost board in the ON position.

When Quiet Shift-2 switch is placed in ON position, and defrost is initiated, the following sequence of operation will occur: The compressor will be de-energized for approximately 1 minute, then the reversing valve will be energized. A few seconds later, the compressor will be re-energized and the normal defrost cycle starts. Once defrost termination conditions have been met, the following sequence will occur: The compressor will be de-energized for approximately 1 minute, then the reversing valve will be de-energized. A few seconds later, the compressor will be re-energized and the normal heating cycle starts.

Defrost

The defrost control is a time/temperature control which has field selectable settings of 30, 60, 90, or 120 minutes, factory set to 90 minutes. These settings represent the amount of time that must pass after closure of the defrost thermostat before the defrost sequence begins.

The defrost thermostat senses coil temperature throughout the heating cycle. When the coil temperature reaches the defrost thermostat setting of approximately 32°F / 0°C, it will close, which energizes the DFT terminal and begins the defrost timing sequence. When the DFT has been energized for the selected time, the defrost cycle begins. Defrost cycle is terminated when defrost thermostat opens at approximately 65° / 18.3°C, or automatically after 10 minutes.

Defrost Speedup

To initiate a forced defrost, speedup pins (J1) must be shorted with a flat head screwdriver for 5 seconds and **RELEASED**. If the defrost thermostat is open, a short defrost cycle will be observed (actual length depends on Quiet Shift switch position). When Quiet Shift is off, only a short 30 second defrost cycle is observed. With Quiet Shift ON, the speedup sequence is one minute; 30 second compressor off period followed by 30 seconds of defrost with compressor operation. When returning to heating mode, the compressor will turn off for an additional 30 seconds and the fan for 40 seconds.

If the defrost thermostat is closed, a complete defrost cycle is initiated. If the Quiet Shift switch is turned on, the compressor will be turned off for two 30 second intervals as explained previously.

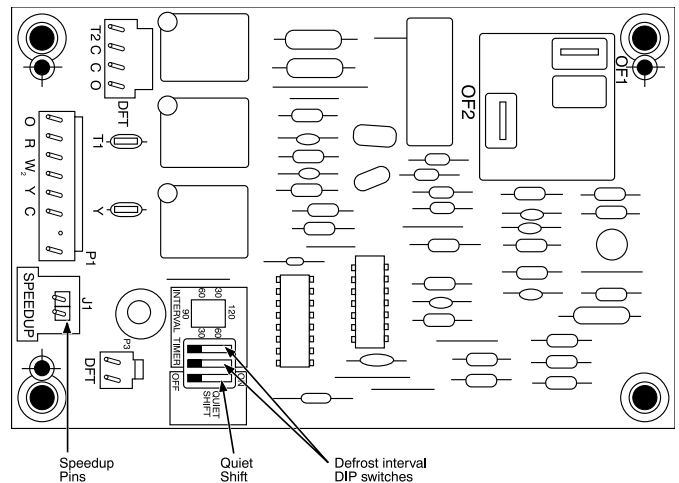

Fig. 35 – Defrost Control

A05378

CHECK CHARGE

(See Charging Tables 10 & 12)

Factory charge amount and desired subcooling are shown on unit rating plate. Charging method is shown on information plate inside unit. To properly check or adjust charge, conditions must be favorable for subcooling charging. Favorable conditions exist when the outdoor temperature is between 70°F / 21.11°C and 100°F / 37.78°C, and the indoor temperature is between 70°F / 21.11°C and 80°F / 26.67°C. Follow the procedure below:

Unit is factory charged for 15ft (4.57 m) of lineset. Adjust charge by adding or removing 0.6 oz/ft of 3/8 liquid line above or below 15ft (4.57 m) respectively.

For standard refrigerant line lengths (80 ft/24.38 m or less), allow system to operate in cooling mode at least 15 minutes. If conditions are favorable, check system charge by subcooling method. If any adjustment is necessary, adjust charge slowly and allow system to operate for 15 minutes to stabilize before declaring a properly charged system.

If the indoor temperature is above 80°F / 26.67°C, and the outdoor temperature is in the favorable range, adjust system charge by weight based on line length and allow the indoor temperature to drop to 80°F / 26.67°C before attempting to check system charge by subcooling method as described above.

If the indoor temperature is below 77°F / 21.11°C, or the outdoor temperature is not in the favorable range, adjust charge for line set length above or below 15ft (4.57 m) only. Charge level should then be appropriate for the system to achieve rated capacity. The charge level could then be checked at another time when the both indoor and outdoor temperatures are in a more favorable range.

NOTE: If line length is beyond 80 ft (24.38 m) or greater than 20 ft (6.10 m) vertical separation, See Long Line Guideline for special charging requirements.

Single-stage AC (*SA5, *SA6) GENERAL SEQUENCE OF OPERATION - standard thermostat

Turn on power to indoor and outdoor units. Transformer is energized.

On a call for cooling, thermostat makes circuits R-Y and R-G. Circuit R-Y energizes contactor, starting outdoor fan motor and compressor circuit. R-G energizes indoor unit blower relay, starting indoor blower motor on high speed.

NOTE: To achieve the rated system performance, the indoor unit or the thermostat must be equipped with a time delay relay circuit.

When thermostat is satisfied, its contacts open, de-energizing contactor and blower relay. Compressor and motors stop. If indoor unit is equipped with a time-delay relay circuit, the indoor blower will run an additional 90 sec to increase system efficiency.

AC control FUNCTIONS AND SEQUENCE OF OPERATION

The outdoor unit control system has special functions. The following is an overview of the control functions.

SEQUENCE OF OPERATION

Cooling Operation

This product utilizes either a standard indoor thermostat or Observer[†] Communicating Wall Control. With a call for cooling, the outdoor fan and compressor are energized. When the cooling demand is satisfied, the compressor and fan will shut off.

NOTE: The outdoor fan motor will continue to operate for one minute after compressor shuts off, when the outdoor ambient is greater than or equal to 100°F / 37.78°C.

Communication and Status Function Lights

Green Communications (COMM) Light (Communicating Control only):

A green LED (COMM light) on the outdoor board indicates successful communication with the other system products. The green LED will remain OFF until communications is established. Once a valid command is received, the green LED will turn ON continuously. If no communication is received within 2 minutes, the LED will be turned OFF until the next valid communication.

Amber Status Light

An amber colored STATUS light is used to display the operation mode and fault codes as specified in the troubleshooting section. See Table 3 for codes and definitions.

NOTE: Only one fault code will be displayed on the outdoor unit control board (the most recent, with the highest priority).

Crankcase Heater Operation

The crankcase heater (when applicable) is energized during the off cycle below 65°F / 18.33°C.

Outdoor Fan motor Operation

The outdoor unit control energizes outdoor fan any time the compressor is operating. The outdoor fan remains energized for 15 minutes if a pressure switch or compressor thermal protector should open. Outdoor fan motor will continue to operate for one minute after the compressor shuts off when the outdoor ambient is greater than or equal to 100°F / 37.78°C.

Time Delays

The unit time delays include:

- Five minute time delay to start cooling operation when there is a call from the thermostat or communicating wall control.
- When operating the unit with 2 wires, this delay is shortened to 10 seconds.

- Five minute compressor recycle delay on return from a brown out condition
- Two minute time delay to return to standby operation from last valid communications (with communicating only)
- One minute time delay of outdoor fan at termination of cooling mode when outdoor ambient is greater than or equal to 100°F / 37.78°C.

Utility Interface

With Non-Communicating Thermostats

Utility curtailment will only work when the unit is operating with a non-communicating thermostat.

When the utility curtailment interface is applied with a non-communicating thermostat, the utility relay should be wired in series with the Y input.

Low Ambient Cooling

When this unit is required to operate below 55° / 12.78°C to a minimum of 0°F / -17.78°C outdoor temperature, provisions must be made for low ambient operation.

Low ambient applications **require** the installation of accessory kits:

- Low Ambient Pressure Switch Kit
- Evaporator Freeze Thermostat
- Hard Start kit
- Crankcase Heater

Support feet are recommended for low ambient cooling. See Product Specification sheet for kit part numbers on appropriate unit size and series unit.

For low ambient cooling with the Observer[†] Communicating Wall Control the cooling lockout must be set to “Off” in the Wall Control setup.

Liquid Line Solenoid

When operating in communicating mode the standard thermostat terminals will not function. A terminal on the non-communicating thermostat bus labeled “LS” on the AC control board is provided for wiring liquid line solenoids when in communicating mode. For operation in communicating mode wire solenoid valve kit NASA401LS across LS and C terminals. For operation in non-communicating mode wire solenoid valve kit NASA401LS across C and Y terminals.

SINGLE-STAGE HEAT PUMP (*SH4, *SH5, *SH6) GENERAL SEQUENCE OF OPERATION - STANDARD THERMOSTAT

Turn on power to indoor and outdoor units. Transformer is energized with power supplied.

Cooling

On a call for cooling, a standard thermostat (non-communicating) makes circuits R-O and R-Y and R-G. Circuit R-O energizes reversing valve, switching it to cooling position. Circuit R-Y energizes contactor, starting outdoor fan motor and compressor circuit. R-G energizes indoor unit blower relay, starting indoor blower motor on high speed.

When a standard thermostat (non-communicating) is satisfied, its contacts open, de-energizing contactor and blower relay. Compressor and motors should stop.

NOTE: If indoor unit is equipped with a time-delay relay circuit, the indoor blower will run an additional 90 seconds to increase system efficiency.

Heating

On a call for heating a standard thermostat (non-communicating) makes circuits R-Y and R-G. Circuit R-Y energizes contactor, starting outdoor fan motor and compressor. Circuit R-G energizes indoor blower relay, starting blower motor on high speed.

Should temperature continue to fall, R-W2 is made through second-stage room thermostat. Circuit R-W2 energizes a relay, bringing on first bank of supplemental electric heat and providing electrical potential to second heater relay (if used). If outdoor temperature falls below setting of outdoor thermostat (factory installed), contacts close to complete circuit and bring on second bank of supplemental electric heat.

When thermostat is satisfied, its contacts open, de-energizing contactor and relay. All heaters and motors should stop after all fan off delays.

HEAT PUMP SYSTEM FUNCTIONS AND SEQUENCE OF OPERATION

The outdoor unit control system has special functions. The following is an overview of the control functions.

SEQUENCE OF OPERATION

Cooling & Heating Operation

This product utilizes either a standard indoor thermostat or Observer[†] Communicating Wall Control. With a call for cooling, the outdoor fan, reversing valve, and compressor are energized. When the cooling demand is satisfied, the compressor and fan will shut off. The reversing valve will remain energized until the control board power is removed or a call for heating is initiated.

NOTE: The outdoor fan motor will continue to operate for one minute after compressor shuts off, when the outdoor ambient is greater than or equal to 100° / 37.78°C.

With a call for heating, the outdoor fan and compressor are energized. The reversing valve is de-energized in the heating mode.

Communication and Status Function Lights

Green Communications (COMM) Light (Communicating Control only):

A green LED (COMM light) on the outdoor board (see Fig. 36) indicates successful communication with the other system products. The green LED will remain OFF until communications is established. Once a valid command is received, the green LED will turn ON continuously. If no communication is received within 2 minutes, the LED will be turned OFF until the next valid communication.

Amber Status Light

An amber colored STATUS light is used to display the operation mode and fault codes as specified in the troubleshooting section. See Table 13 for codes and definitions.

NOTE: Only one fault code will be displayed on the outdoor unit control board (the most recent, with the highest priority).

Crankcase Heater Operation

The crankcase heater (when applicable) is energized during the off cycle below 65° / 18.83°C.

Outdoor Fan motor Operation

The outdoor unit control energizes outdoor fan any time the compressor is operating (except defrost and intermittently during low ambient cooling). The outdoor fan remains energized for 15 minutes if a pressure switch or compressor thermal protector should open. Outdoor fan motor will continue to operate for one minute after the compressor shuts off when the outdoor ambient is greater than or equal to 100°F / 37.78°C.

Time Delays

The unit time delays include:

- Five minute time delay to start cooling or heating operation when there is a call from the thermostat. (To bypass this feature in a non-communicating system, momentarily short and release forced defrost pins.
- Five minute compressor recycle delay on return from a brown out condition
- Two minute time delay to return to standby operation from last valid communications (with Observer[†] communicating wall control only)

- One minute time delay of outdoor fan at termination of cooling mode when outdoor ambient is greater than or equal to 100°F / 37.78°C.
- Fifteen second delay at termination of defrost before the auxiliary heat (W2) is de-energized.
- Twenty second delay at termination of defrost before the outdoor fan is energized.
- Seventy and sixty second compressor delays when Quiet Shift-2 enabled.

Utility Interface

With Non-Communicating Thermostats

Utility curtailment will only work when the unit is operating with a non-communicating thermostat.

When the utility curtailment interface is applied with a non-communicating thermostat, the utility relay should be wired between R & Y.

Low Ambient Cooling

When this unit is required to operate below 55°F / 12.78°C to a minimum of 0°F / -17.78°C outdoor temperature, provisions must be made for low ambient operation.

Low ambient applications **require** the installation of accessory kits:

- Non-communicating thermostat
- Low Ambient Pressure Switch Kit
- Evaporator Freeze Thermostat
- Hard Start kit
- Crankcase Heater
- Field Supplied Isolation Relay

Support feet are recommended for low ambient cooling. See Product Specification sheet for kit part numbers on appropriate unit size and series unit.

DEFROST

This control offers 4 possible defrost interval times: 30, 60, 90 or 120 minutes. They are selected by dip switches on the control board, or in the Observer[†] Communicating Wall Control (if used). The Observer Communicating Wall Control selection overrides the control board dip switch settings.

Auto defrost is available with Observer Communicating Wall Control only and it must be enabled in the Wall Control. Auto defrost adjusts the defrost interval time based on the last defrost time as follows:

- When defrost time is < 3 minutes, the next defrost interval = 120 minutes
- When defrost time is 3-5 minutes, the next defrost interval = 90 minutes
- When defrost time is 5-7 minutes, the next defrost interval = 60 minutes
- When defrost time is > 7 minutes, the next defrost interval = 30 minutes

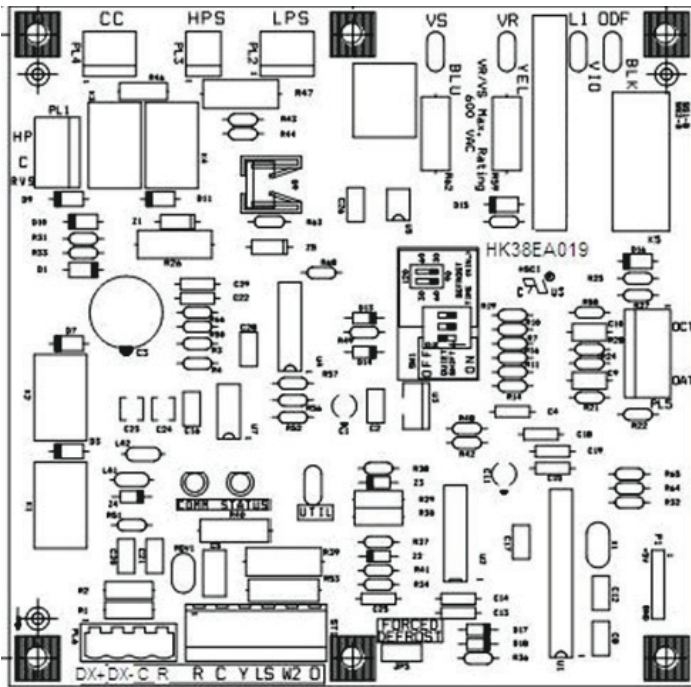

Fig. 36 – Heat Pump Single Stage Control Board

HK38EA019

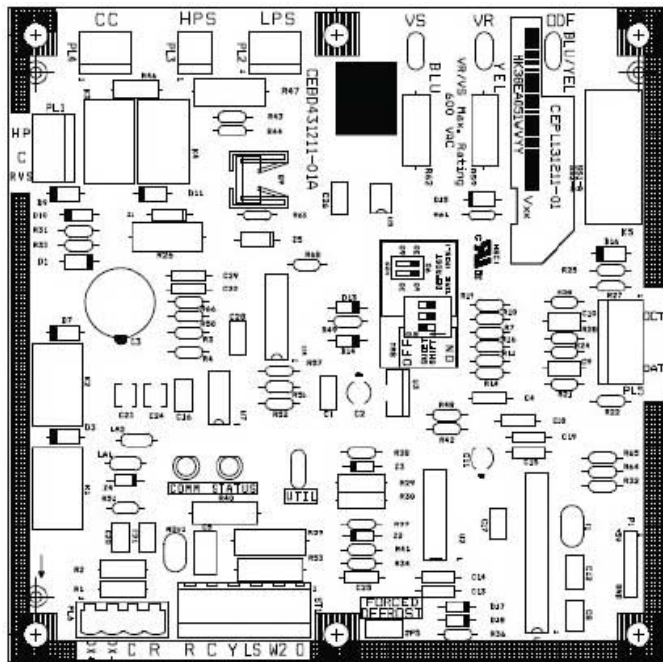

Fig. 37 – Control Board 1190261 (for units with ECM Fan Motor)

CEPL131211

The control board accumulates compressor run time. As the accumulated run time approaches the selected defrost interval time, the control board monitors the coil temperature sensor for a defrost demand. If a defrost demand exists, a defrost cycle will be initiated at the end of the selected time interval. A defrost demand exists when the coil temperature is at or below 32°F / 0°C for 4 minutes during the interval.

The defrost cycle is terminated when the coil temperature reaches 65°F / 18.33°C or 10 minutes has passed.

If the coil temperature does not reach 32°F / 0°C within the interval, the interval timer will be reset and start over.

NOTE:

- Upon initial power up the first defrost interval is defaulted to 30 minutes. Remaining intervals are at selected times.

- Defrost is only allowed to occur below 50°F / 10°C outdoor ambient temperature.
- The Quiet Shift-2 compressor on/off delays, as described below, will be included in a forced defrost if Quiet Shift-2 is enabled.

DEFROST HOLD

In a non-communicating system, if the thermostat becomes satisfied before the defrost cycle is terminated, the control will "hold" in defrost mode and finish the defrost cycle on the next call for heat. Defrost hold is not needed in a communicating system because the Wall Control will complete the defrost cycle before shutting down the system.

FORCED DEFROST

Forced defrost can be initiated manually in a non-communicating system, or by communicated command from a Wall Control. The board contains a 2-pin header labeled FORCED DEFROST (See Figure 13). To initiate a forced defrost:

- Manually, short FORCED DEFROST pins for 5 seconds then release
- If coil temp is at defrost temp of 32°F / 0°C, and outdoor air temperature is below 50°F / 10°C a full defrost sequence will occur
- If the coil temp or outdoor air temperature do not meet the above requirements, an abbreviated 30 second defrost will occur

QUIET SHIFT-2

Quiet Shift-2 is a field-selectable defrost mode which may eliminate occasional noise that could be heard at the start and finish of the defrost cycle. For installations using a standard 2-stage thermostat, this feature must be enabled by selecting the 3rd position dip switch on the outdoor control board. For installations using an Observer[†] Wall Control, this feature must be enabled at the Wall Control. When activated, the following sequence of operation occurs: **Defrost Initiation** - the compressor is de-energized for 70 seconds. During this 70 second compressor off time, the reversing valve will be energized. Once the 70 second compressor off time has been reached, the compressor will be energized then the outdoor fan will be de-energized at which time the normal defrost cycle begins. **Defrost Termination** - the outdoor fan will be energized shortly before the compressor is de-energized for 60 seconds. During the compressor 60 second off time, the reversing valve will be deenergized. Once the 60 second compressor off time has been completed, the compressor will be energized at which time the system will be in normal heat mode.

LIQUID LINE SOLENOID ACCESSORY

In heat pump long line applications, a liquid line solenoid is required to control refrigerant migration in the heating mode. The solenoid should be installed near the outdoor unit with the arrow facing the outdoor unit. This is the direction of flow control. See Long Line Application Guideline for details.

Accessory Liquid Solenoid with Observer[†] Communicating Wall Control: When using the Observer Communicating Wall Control, a liquid line solenoid output labeled LS is provided. Connect the solenoid as shown in the wiring label diagram. This is a 24vac output that is energized whenever the compressor is energized. It closes in the compressor-off mode to prevent refrigerant migration into the unit through the liquid line.

Accessory Liquid Solenoid with Non-Communicating Thermostat: The liquid solenoid is connected to the Y and C terminal connections. The liquid solenoid closes in the compressor-off mode to prevent refrigerant migration into the unit through the liquid line.

MAJOR COMPONENTS

Control Board

The Heat Pump control board controls the following functions:

- Compressor contactor operation
- Outdoor fan motor operation
- Reversing valve operation
- Defrost operation
- Compressor external protection
- Pressure switch monitoring
- Time delays

Field Connections

When using the Observer[†] Communicating Wall Control, 4 field wires are required. On single-stage units they are connected to the factory wires already wired to the DX+DX-CR terminal (see Fig. 36). Unit as provided by manufacturer is set up for the Observer Communicating Wall Control.

When used with a standard non-communicating thermostat, 5 field wires are required to be connected to R, Y, W2, O and C. Disconnect factory provided wires from DX+, DX-, C, and R terminals. Using factory provided wires, connect to R, Y, W2, O and C terminals on the control board. Connect field 24V wires to factory provided wires now connected to R, Y, W2, O and C and unused factory provided wires.

When using Observer[†] communication wall control only, the 24vac LS (liquid solenoid) output terminal is energized for the liquid solenoid accessory. The connection is located at the side of the control board just below the DX+DX-CR connector.

Compressor Internal Relief

The compressor is protected by an internal pressure relief (IPR) which relieves discharge gas into the compressor shell when differential between suction and discharge pressure exceeds 550-625 psi. The compressor is also protected by an internal overload attached to motor windings.

TROUBLESHOOTING (Single-stage)

Systems Communication Failure

If communication between Wall Control, and condensing unit is lost, the outdoor control will flash the appropriate fault code. (See Table 13) Check the wiring to the Wall Control, indoor and outdoor units.

Pressure Switch Protection

The outdoor unit is equipped with high- and low-pressure switches. If the control senses the opening of a high or low-pressure switch, it will de-energize the compressor contactor, keep the outdoor fan operating for 15 minutes and display the appropriate fault code. (See table 13)

After a 15 minute delay, if there is still a call for cooling, and the LPS or HPS is reset, the compressor contactor is energized. If the LPS or HPS has not closed after a 15 minute delay, the outdoor fan is turned off. If the open switch closes anytime after the 15-minute delay, then the unit will resume operation with a call for cooling.

If the LPS or HPS trips for five consecutive cycles, then unit operation is locked out for 4 hours and the appropriate fault code (See table 13) is displayed.

In the event of a high-pressure switch trip or high-pressure lockout, check the refrigerant charge, outdoor fan operation and outdoor coil (in cooling) for airflow restrictions, or indoor airflow in heating.

In the event of a low-pressure switch trip or low-pressure lockout, check the refrigerant charge and indoor airflow (cooling) and for HP, outdoor fan operation and outdoor coil in heating.

Control Fault

If the outdoor unit control board has failed, the control will flash the appropriate fault code. (See table 13) The control board should be replaced.

24v Brown Out Protection

If the control voltage is less than 15.5 volts for at least 4 seconds, the compressor contactor and fan relay are de-energized. Compressor and fan operation are not allowed until control voltage is a minimum of 17.5 volts. The control will flash the appropriate fault code. (See table 13) Verify the control voltage is in the allowable range of 18-30 volts.

Compressor Voltage Sensing

The input terminals labeled VR and VS on the control board (see Fig. 36) are used to detect compressor voltage status, and alert the user of potential problems. The control continuously monitors the high voltage on the run capacitor of the compressor motor. Voltage should be present any time the compressor contactor is energized, and voltage should not be present when the contactor is de-energized.

Compressor Thermal Cutout Or Loss of 230v Power

If the control senses the compressor voltage after start-up, and is then absent for 10 consecutive seconds while cooling demand exists, it will de-energize the compressor contactor, keep the outdoor fan operating for 15 minutes (if 230v power present) and display the appropriate fault code. (See table 13) Possible causes are compressor internal overload trip or loss of high voltage (230V) to compressor without loss of control voltage.

After a 15 minute delay, if there is still a call for cooling, the compressor contactor is energized. If the thermal protector has not re-set, the outdoor fan is turned off. If the call for cooling continues, the control will energize the compressor contactor every 15 minutes. If the thermal protector closes, (at the next 15 minute interval check), the unit will resume operation.

If the thermal cutout trips for three consecutive cycles, then unit operation is locked out for 4 hours and the appropriate fault code (See Table 13) is displayed.

Contactor Shorted Detection

If there is compressor voltage sensed when there is no demand for compressor operation, the contactor may be stuck closed. The control will flash the appropriate fault code. Check the contactor and control box wiring.

No 230v At Compressor

If the compressor voltage is not sensed when the compressor should be starting, the contactor may be stuck open or the unit disconnect or circuit breaker may be open. The control will flash the appropriate fault code. Check the contactor, unit disconnect or circuit breaker and control box wiring.

Temperature Thermistors

Thermistors are electronic devices which sense temperature. As the temperature increases, the resistance decreases. Thermistors are used to sense outdoor air (OAT) and coil temperature (OCT). Refer to Fig. 38 for resistance values versus temperature.

If the outdoor air or coil thermistor should fail, the control will flash the appropriate fault code. (See table 13).

IMPORTANT: IMPORTANT: The outdoor air thermistor and coil thermistor are factory mounted in the correct locations. Do not re-locate thermistor sensors.

Thermistor Sensor Comparison

The control continuously monitors and compares the outdoor air temperature sensor and outdoor coil temperature sensor to ensure proper operating conditions. The comparison is:

- In cooling if the outdoor air sensor indicates $\{ \} 10^{\circ}\text{F} / -12.22^{\circ}\text{C}$ warmer than the coil sensor (or) the outdoor air sensor indicates $\{ \} 20^{\circ}\text{F} / -6.67^{\circ}\text{C}$ cooler than the coil sensor, the sensors are out of range.
- In heating if the outdoor air sensor indicates $\{ \} 35^{\circ}\text{F} / 1.67^{\circ}\text{C}$ warmer than the coil sensor (or) the outdoor air sensor indicates $\{ \} 10^{\circ}\text{F} / -12.22^{\circ}\text{C}$ cooler than the coil sensor, the sensors are out of range.

If the sensors are out of range, the control will flash the appropriate fault code. (See Table 13).

The thermistor comparison is not performed during low ambient cooling or defrost operation.

Failed Thermistor Default Operation

Factory defaults have been provided in the event of failure of outdoor air thermistor and/or coil thermistor.

If the OAT sensor should fail, low ambient cooling will not be allowed and the one-minute outdoor fan off delay will not occur. Defrost will be initiated based on coil temperature and time.

If the OCT sensor should fail, low ambient cooling will not be allowed. Defrost will occur at each time interval during heating operation, but will terminate after 5 minutes.

If there is a thermistor out of range error, defrost will occur at each time interval during heating operation, but will terminate after 5 minutes.

Thermistor Curve: The resistance vs. temperature chart shown in Figure 38 enables the technician to check the outdoor air and outdoor coil thermistors for proper resistance. Unplug the thermistor assembly from the circuit board and measure resistance across each thermistor. For example, if the outdoor temperature is $60^{\circ}\text{F} / 15.56^{\circ}\text{C}$, the resistance reading across the outdoor air thermistor should be around 16,000 Ohms.

Status Codes

Table 12 shows the status codes flashed by the amber status light. Most system problems can be diagnosed by reading the status code as flashed by the amber status light on the control board.

The codes are flashed by a series of short and long flashes of the status light. The short flashes indicate the first digit in the status code, followed by long flashes indicating the second digit of the error code. The short flash is 0.25 second ON and the long flash is 1.0 second ON. Time

between flashes is 0.25 second. Time between short flash and first long flash is 1.0 second. Time between code repeating is 2.5 seconds with LED OFF.

Count the number of short and long flashes to determine the appropriate flash code. Table 13 gives possible causes and actions related to each error.

Example: 3 short flashes followed by 2 long flashes indicates a 32 code. Table 13 shows this to be low pressure switch open.

Table 13 – Status Codes

OPERATION	FAULT	AMBER LED FLASH CODE	Possible Cause and Action
Standby – no call for unit operation	None	On solid, no flash	Normal operation - with communicating Control
Standby – no call for unit operation	None	Off	Normal operation - No call for cooling with 2-wire connection or indoor unit not powered.
Cooling Operation	None	1, pause	Normal operation
	System Communications Failure	16	Communication with wall control lost. Check wiring to wall control, indoor and outdoor units
	High Pressure Switch Open	31	High pressure switch trip. Check refrigerant charge, outdoor fan operation and coils for airflow restrictions.
	Low Pressure Switch Open	32	Low pressure switch trip. Check refrigerant charge and indoor air flow
	Control Fault	45	Outdoor unit control board has failed. Control board needs to be replaced.
	Brown Out (24 v)	46	The control voltage is less than 15.5v for at least 4 seconds. Compressor and fan operation not allowed until control voltage is a minimum of 17.5v. Verify control voltage.
	Outdoor Air Temp Sensor Fault	53	Outdoor air sensor not reading or out of range. Ohm out sensor and check wiring
	Outdoor Coil Sensor Fault	55	Coil sensor not reading or out of range. Ohm out sensor and check wiring
	Thermistors out of range	56	Improper relationship between coil sensor and outdoor air sensor. Ohm out sensors and check wiring.
	Thermal Cutout	72	Compressor voltage sensed after start-up, then absent for 10 consecutive seconds while cooling demand exists. Possible causes are internal compressor overload trip or loss of high voltage to compressor without loss of control voltage. The control will continue fan operation and wait 15 minutes to attempt a restart. Fault will clear when restart is successful, or low voltage power is cycled.
	Contactors Shorted	73	Compressor voltage sensed when no demand for compressor operation exists. Contactor may be stuck closed or there is a wiring error.
	No 230V at Compressor	74	Compressor voltage not sensed when compressor should be starting. Disconnect may be open or contactor may be stuck open or there is a wiring error.
	Thermal Lockout	82	Thermal cutout occurs in three consecutive cycles. Unit operation locked out for 4 hours or until 24v power recycled.
	Low Pressure Lockout	83	Low pressure switch trip has occurred during 3 consecutive cycles. Unit operation locked out for 4 hours or until 24v power recycled.
	High Pressure Lockout	84	High pressure switch trip has occurred during 3 consecutive cycles. Unit operation locked out for 4 hours or until 24v power recycled.

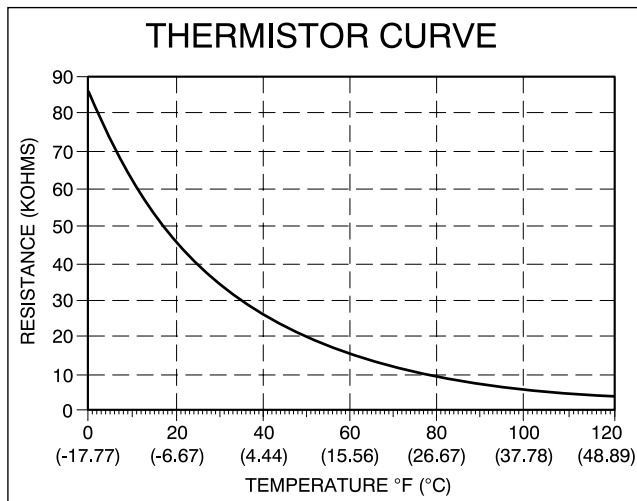

Fig. 38 – Resistance vs Temperature Chart

A08054

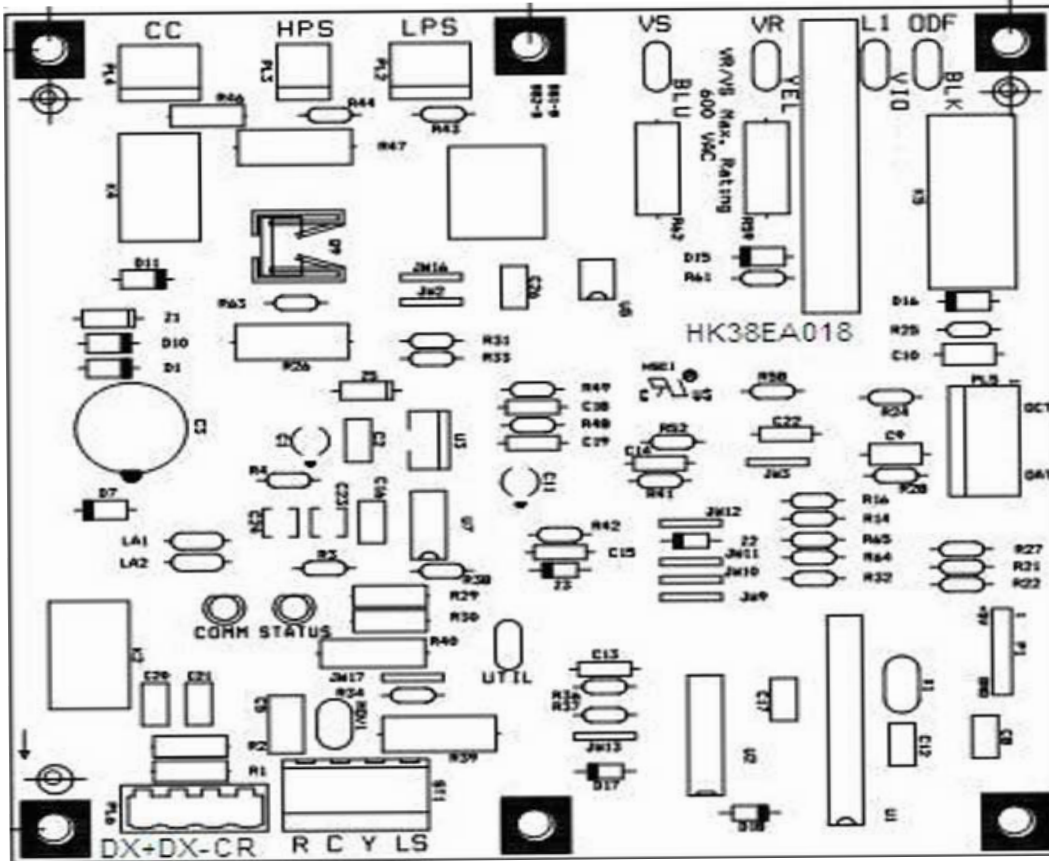

Fig. 39 – Fig. AC Single Stage Control Board

HK38EA018

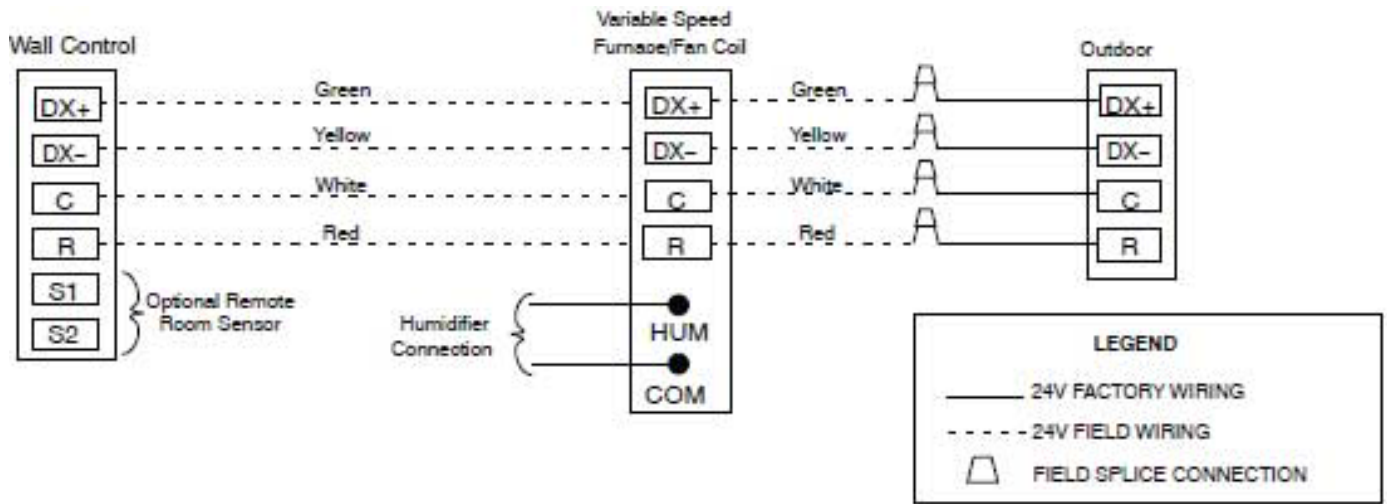

Fig. 40 – Observer Communicating Wall Control Four-Wire Connection Wiring Diagrams
 (See Thermostat Installation Instructions for specific unit combinations)

A221552

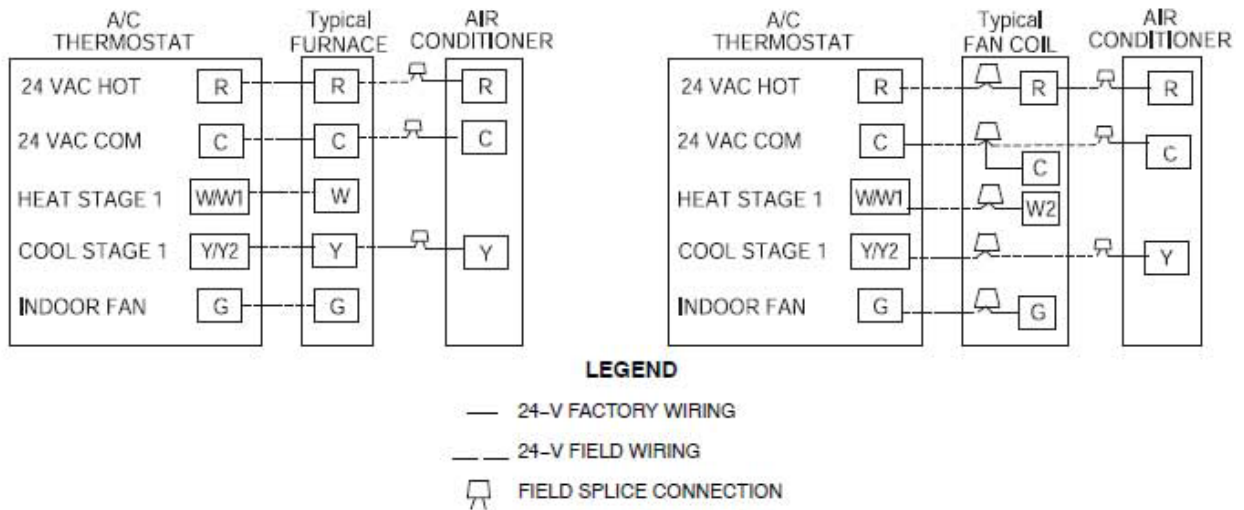

Fig. 41 – Non-Communicating Standard Thermostat 3-Wire 24V Circuit Connections
 (See Thermostat Installation Instructions for Specific Unit combinations)

A230006

! CAUTION

ELECTRICAL OPERATION HAZARD

Failure to follow this caution may result in equipment damage or improper operation.

A minimum of three wire thermostat wiring is required for the system to operate.

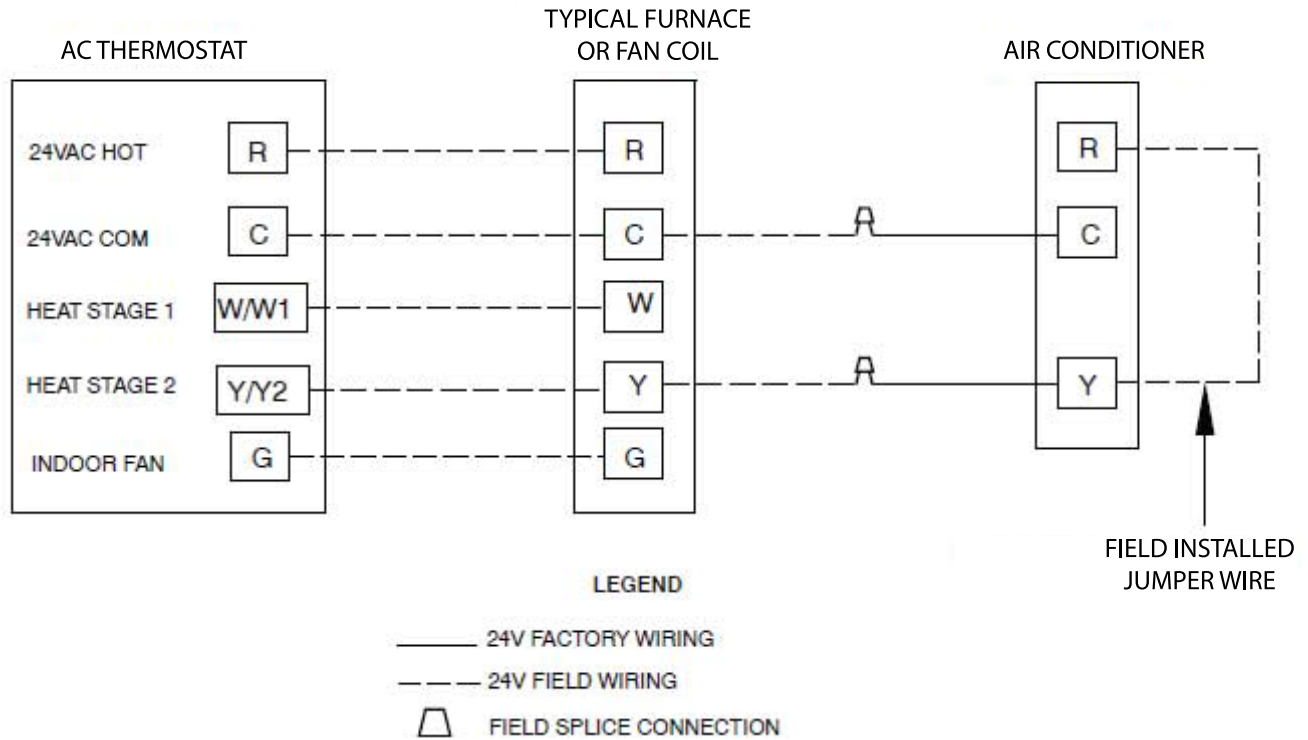

Fig. 42 – Non-Communicating Standard Thermostat 2-Wire 24V Circuit Connections

A230008

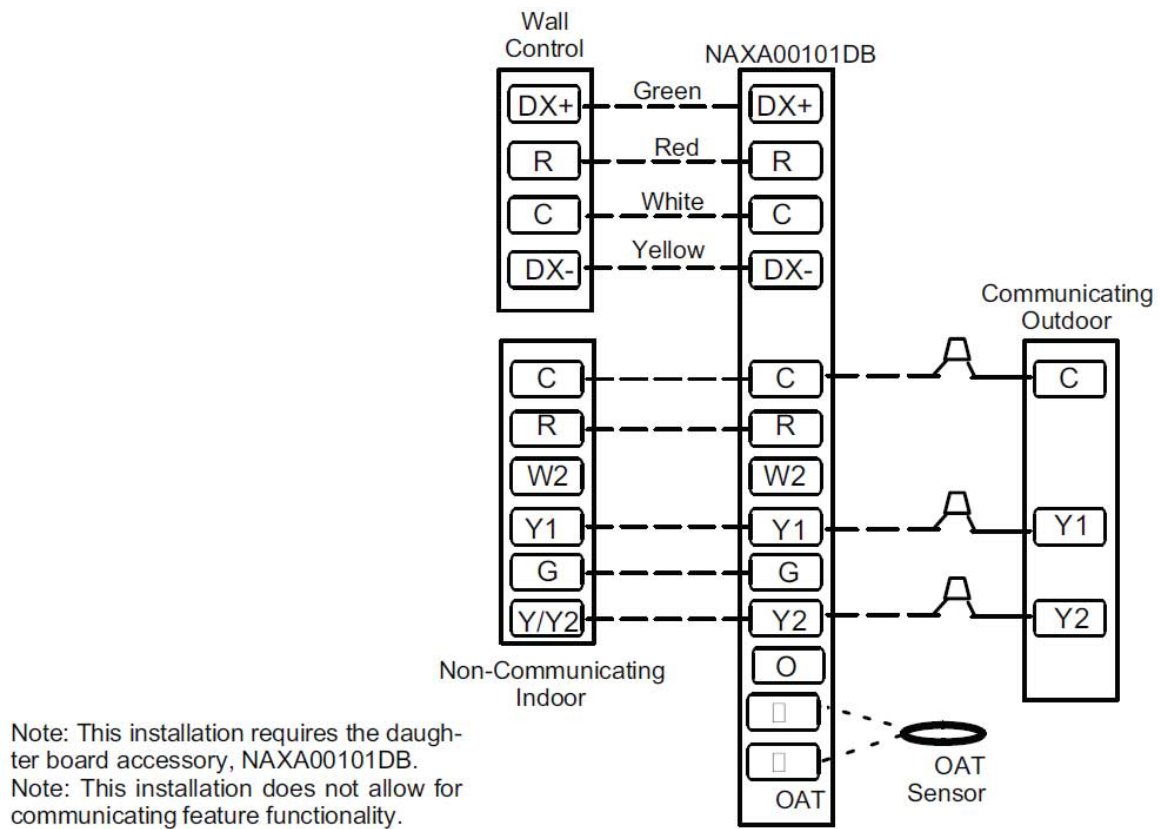

Fig. 43 – Non-Communicating Indoor with Observer } Communicating Wall Control

A221551

TWO-STAGE *CA7, *CA9, *CH6, *CH9

Application Guidelines

ICP designed and tested the two-stage air conditioner and heat pump products with R-410A refrigerant to operate at a minimum outdoor operating ambient in cooling mode at 55°F / 12.8°C and the maximum outdoor operating ambient in cooling is 125°F / 51.6°C. The maximum outdoor operating ambient in heating mode is 66°F / 18.9°C. Continuous operation in heating mode is approved to -30°F / -34.4°C. Thermostat options for the two stage units are as follows:

- C, Dx-, Dx+, R four-wire connections for Communicating wall control.
- W,Y1,Y2, and O wire connections for standard, non-communicating thermostat.

*CA7, *CA9, *CH6, and *CH9 units can run, and are matched with, both Observer® communicating wall control and non-communicating 2-stage indoor fan coils and furnaces. Only unit combinations listed in the two-stage specifications, technical support manuals, or AHRIdirectory.org are recommended.

Line sets for two stage units are similar to the single stage units. However, some restrictions may apply to specific combinations in long line applications. Refer to the Split System Long Line Applications Guidelines for further information.

The Tennessee Valley Authority (TVA) requires that electric strip heat have a lockout feature. This is achieved through Observer® communicating wall control must be used on all TVA approved units.

Model Plug

Each control board contains a model plug. The correct model plug must be installed in order for the system to operate properly. (See Table 14.)

The model plug is used to identify the type and size of unit to the control. On *CH6 models, the model plug is also used to determine the start sequence timing for each individual model.

On new units, the model and serial numbers are inputted into the board's memory at the factory. If a model plug is lost or missing at initial installation, the unit will operate according to the information input at the factory and the appropriate error code will flash temporarily. A FAST Parts replacement board contains no model and serial information. If the factory control board fails, the model plug must be transferred from the original board to the replacement board for the unit to operate.

NOTE: The model plug takes priority over factory model information input at the factory. If the model plug is removed after initial power up, the unit will operate according to the last valid model plug installed, and flash the appropriate fault code temporarily.

Table 14 – Model Plug Information

MODEL NUMBER	MODEL PLUG NUMBER	PIN RESISTANCE (K-ohms)	
		Pins 1-4	Pins 2-3
*CH624	HK70EZ041	18	91
*CH636	HK70EZ043	18	150
*CH648	HK70EZ045	18	220
*CH660	HK70EZ047	18	360
*CH924	HK70EZ010	5.1	120
*CH936	HK70EZ012	5.1	180
*CH948	HK70EZ014	5.1	270
*CH960	HK70EZ016	11	5.1
*CA924	HK70EZ009	5.1	91
*CA936	HK70EZ011	5.1	150
*CA948	HK70EZ013	5.1	220
*CA960	HK70EZ015	5.1	360
*CA624	HK70EZ040	18	75
*CA636	HK70EZ042	18	120
*CA648	HK70EZ044	18	180
*CA660	HK70EZ046	18	270

Airflow Selections for *CA7, *CA9, *CH6, *CH9 Using Non-Communicating Thermostats

Airflow Selection for FVM4 Fan Coils for *CA7, *CA9, *CH6, *CH9 Using Non-Communicating Thermostats

The FVM4 provides high- and low-stage blower operation to match the capacities of compressor at high- and low-stage. To select recommended airflow, refer to FVM4 Installation Instructions. The FVM4 utilizes an Easy Select control board that allows the installing technician to select proper airflows. For adjustments to control board, select appropriate HP SIZE and CFM ADJUST setting. This fan coil has an adjustable blower off delay factory set at 90 sec for high- and low-stage blower operation.

For other combinations of equipment consult specifications, technical support manuals, or AHRIdirectory.org.

GENERAL INFORMATION

Defrost

This control offers 5 possible defrost interval times: 30, 60, 90, 120 minutes, or AUTO.

With non-communicating thermostats, these are selected by dip switches on the unit control board. With Communicating thermostats, the Communicating control wall control. The Communicating control selection overrides the control board dip switch settings.

AUTO defrost adjusts the defrost interval time based on the last defrost time as follows:

- When defrost time <3 minutes, the next defrost interval=120 minutes.
- When defrost time 3-5 minutes, the next defrost interval=90 minutes.
- When defrost time 5-7 minutes, the next defrost interval=60 minutes.
- When defrost time >7 minutes, the next defrost interval=30 minutes.

The control board accumulates compressor run time. As the accumulated run time approaches the selected defrost interval time, the control board monitors the coil temperature sensor for a defrost demand. If a defrost demand exists, a defrost cycle will be initiated at the end of the selected time interval. A defrost demand exists when the coil temperature is at or below 32°F for 4 minutes during the interval.

The defrost cycle is terminated when the coil temperature reaches 65°F or 10 minutes has passed.

On *CH6 models, defrost will occur in low- or high-stage as demanded by the thermostat or wall control regardless of OAT.

On *CH9 models, when OAT is >25°F / -3.9°C, defrost will occur in low- or high-stage as demanded by the thermostat or wall control.

On *CH9 models, if OAT is ≤25°F / -3.9°C, defrost will occur in high-stage only, regardless of thermostat or wall control demand, and will terminate at 50°F / coil temperature with a minimum of 2.5 minutes in defrost.

If the coil temperature does not reach 32°F / 0°C within the interval, the interval timer will be reset and start over.

- Upon initial power up the first defrost interval is defaulted to 30 minutes. Remaining intervals are at selected times.
- Defrost is only allowed to occur below 50°F / 10°C outdoor ambient temperature.

The outdoor fan output (ODF) will remain off for 20 seconds after termination. This delay will allow time for the system to capture the heat from the outdoor coil and reduce the “steam cloud” effect that may occur on transition from defrost to the heating cycle. The outdoor fan output OFF delay of 20 seconds may be defeated to enable the fan to energize immediately at the time of termination and 12 seconds prior to the reversing valve de-energizing, through forced defrost pins as follows:

- The ODF fan delay defeat can be toggled by shorting the forced defrost pins for >15 seconds while in the standby mode (status LED on solid). The LED will start to flash when the toggle has taken place.
- Status code 4 shows the fan delay defeat is active (no delay)
- Status code 3 shows that it is not active (20 second delay)

The code will continue to be displayed until after the short is removed. Once the short is removed, there is a 5 second wait before the code is canceled. The code that is flashing will finish before going back to solid LED. The control is shipped with the ODF fan delay defeat NOT active. The change in status is remembered until toggled to a new status. A power down / power up sequence will not reset the status. It may be necessary to do the toggle twice to cycle to the desired state of defeat.

Defrost Hold

In a non-communicating system, if the thermostat becomes satisfied (Y1 or Y1 and Y2) before the defrost cycle is terminated, the control will “hold” in defrost mode and finish the defrost cycle on the next call for heat.

With Communicating control, defrost hold is not needed in a Communicating system because the wall control will complete the defrost cycle before shutting down the system.

Forced Defrost

With non-communicating control, forced defrost can be initiated by manually shorting the 2-pin header labeled FORCED DEFROST (see Fig 46) on the control board for 5 seconds then releasing.

With Communicating control, forced defrost is initiated with the wall control.

On all models, during a Forced Defrost:

- If coil temperature is at defrost temperature of 32°F / 0°C, and outdoor air temperature is below 50°F / 10°F, a full defrost sequence will occur.
- If coil temperature or outdoor air temperature does not meet the above requirements, an abbreviated 30 second defrost will occur.
- Both Quiet Shift and Quiet Shift-2 compressor ON/OFF delays will be included in a forced defrost if either are enabled.

Quiet Shift-2 (Communicating models) (FAST # 1185237, 1186140)

Quiet Shift-2 is a field selectable defrost mode which may eliminate occasional noise that could be heard at the start and finish of the defrost cycle.

On a non-communicating system, this feature must be enabled by selecting the 3rd position of the 3-position dip switch on the outdoor control board. For Communicating systems, it must be enabled at the wall control. When activated, the following sequence of operation occurs:

Defrost Initiation – The compressor is de-energized for 70 seconds. During this 70 second compressor off time, the reversing valve will be energized. Once the 70 second compressor off time has been reached, the compressor will be energized then the outdoor fan will be de-energized at which time the normal defrost cycle begins.

Defrost Termination – the outdoor fan will be energized shortly before the compressor is de-energized for 60 seconds. During the compressor 60 second off time, the reversing valve will be de-energized. Once the 60 second compressor off time has been completed, the compressor will be energized at which time the system will be in normal heat mode.

Liquid-Line Solenoid Accessory

In heat pump long-line applications, a liquid-line solenoid is required to control refrigerant migration in the heating mode. The solenoid should be installed near the outdoor unit with the arrow facing the outdoor unit. This is the direction of flow control. See Split System Long Line Applications Guidelines for long-line application details.

Accessory Liquid Solenoid with Communicating Control:

When using the Communicating control, the liquid-line solenoid output is provided at the Y1 connection. Connect the solenoid as shown in the wiring label diagram. This is a 24vac output that is energized whenever the compressor is energized. It closes, in the compressor off mode, to prevent refrigerant migration into the unit through the liquid-line.

On Models with Accessory Liquid Solenoid Using a Non-Communicating Thermostat:

The liquid solenoid is connect to the Y1 and C terminal connections. The liquid solenoid closes, in the compressor off mode, to prevent refrigerant migration into the unit through the liquid-line.

Check Charge

All Two-Stage units must be charged in high stage only.

(See Charging Tables 8 & 10)

Factory charge amount and desired subcooling are shown on unit rating plate. Charging method is shown on information plate inside unit. To properly check or adjust charge, conditions must be favorable for subcooling charging. Favorable conditions exist when the outdoor temperature is between 70°F and 100°F (21.11°C and 37.78°C), and the indoor temperature is between 70°F and 80°F (21.11°C and 26.67°C). Follow the procedure below:

Unit is factory charged for 15ft (4.57 m) of lineset. Adjust charge by adding or removing 0.6 oz/ft of 3/8 liquid line above or below 15ft (4.57 m) respectively.

For standard refrigerant line lengths (80 ft/24.38 m or less), allow system to operate in cooling mode at least 15 minutes. If conditions are favorable, check system charge by subcooling method. If any adjustment is necessary, adjust charge slowly and allow system to operate for 15 minutes to stabilize before declaring a properly charged system.

If indoor temperature is above 80°F (26.67°C), and outdoor temperature is in the favorable range, adjust system charge by weight based on line length and allow indoor temperature to drop to 80°F (26.67°C) before attempting to check system charge using subcooling method described above.

If the indoor temperature is below 70°F (21.11°C), or the outdoor temperature is not in the favorable range, adjust charge for line set length above or below 15ft (4.57 m) only. Charge level should then be appropriate for the system to achieve rated capacity. The charge level could then be checked at another time when the both indoor and outdoor temperatures are in a more favorable range.

NOTE: If line length is beyond 80 ft (24.38 m) or greater than 20 ft (6.10 m) vertical separation, see Split System Long Line Applications Guidelines for special charging requirements.

Heating Check Chart Procedure

To check system operation during heating cycle, refer to the Tech Label on outdoor unit. This chart indicates whether a correct relationship exists between system operating pressure and air temperature entering indoor and outdoor units. If pressure and temperature do not match on chart, system refrigerant charge may not be correct. Do not use chart to adjust refrigerant charge.

NOTE: When charging is necessary during heating season, charge must be weighed in accordance with unit rating plate, ± 0.6 oz./ft. of 3/8-in. liquid-line above or below 15 ft., respectively.

EXAMPLE:

To calculate additional charge required for a 25-ft. line set:
25 ft. - 15 ft. = 10 ft. X 0.6 oz./ft. = 6 oz. of additional charge.

System Functions and Sequence of Operation (*CA7, *CA9, *CH6, *CH9)

The outdoor unit control system has special functions. The following is an overview of the two-stage control functions:

Cooling and Heating Operation

The *CA7, *CA9, *CH6, and *CH9 model utilizes either a standard 2-stage indoor thermostat or Communication wall control. With a call for first stage cooling, the outdoor fan, reversing valve, and low stage compressor are energized. If low-stage cannot satisfy cooling demand, high-stage cooling is energized by the second stage of indoor thermostat or wall control. After second stage is satisfied, the unit returns to low-stage operation until first stage is satisfied or until second stage is required again. When both first stage and second stage cooling are satisfied, the compressor will shut off. The reversing valve will remain energized until the control board power is removed or a call for heating is initiated. With a call for heating, the outdoor fan and compressor are

energized. The compressor will operate in high or low stage operation, as needed to meet the heating demand. When the heating demand is satisfied, the compressor and fan will shut off. The reversing valve is de-energized in the heating mode.

NOTE: When two-stage unit is operating at low-stage, system vapor (suction) pressure will be higher than a standard single-stage system or high-stage operation.

NOTE: Outdoor fan motor will continue to operate for one minute after compressor shuts off, when outdoor ambient is greater than or equal to 100°F. This reduces pressure differential for easier starting on next cycle.

NOTE: If unit has not operated within the past 12 hours, or following a unit power-up, upon the next thermostat high- or low-stage demand, unit operates for a minimum of 5 minutes in high-stage.

On models with non-communicating systems, with first stage of cooling, Y1 and O are powered on; and with second stage of cooling, Y1, Y2, and O are on. For these systems, with first stage of heating Y1 is on and for second stage of heating, Y1 and Y2 are on. When the reversing valve is energized, O is powered on.

Communication and Status Function Lights For Communicating Control only, Green communications (COMM) Light

A green LED (**COMM light**) on the outdoor board indicates successful communication with the other system products. The green LED will remain OFF until communication is established. Once a valid command is received, the green LED will turn ON continuously. If no communication is received within 2 minutes, the LED will be turned OFF until the next valid communication.

Amber Status Light

An amber colored **STATUS light** is used to display the operation mode and fault codes as specified in the troubleshooting section. See Table 17 for codes and definitions.

NOTE: Only one code will be displayed on the outdoor unit control board (the most recent, with the highest priority).

Compressor Operation

The basic scroll design has been modified, adding an internal unloading mechanism that opens a bypass port in the first compression pocket, effectively reducing the displacement of the scroll. Opening and closing of the bypass port is controlled by an internal electrical solenoid.

The modulated scroll uses a single step of unloading to go from full capacity to approximately 67% capacity. A single speed, high efficiency motor continues to run while the scroll modulates between the two capacity steps. Modulation is achieved by venting a portion of the gas in the first suction pocket back to the low side of the compressor, thereby reducing the effective displacement of the compressor. Full capacity is achieved by blocking these ports, thus increasing the displacement to 100%. A DC solenoid in the compressor controlled by a rectified 24 volt AC signal in the external solenoid plug moves the slider ring that covers and uncovers these ports. The port covers are arranged in such a manner that the compressor operates at approximately 67% capacity when the solenoid is not energized and 100% capacity when the solenoid is energized.

The loading and unloading of the two step scroll is done “on the fly” without shutting off the motor between steps.

NOTE: 67% compressor capacity translates to approximately 75% cooling or heating capacity at the indoor coil. The compressor will always start unloaded and stay unloaded for five seconds even when the thermostat is calling for high stage.

Fan Motor

Fan motor rotates the fan blade that either draws or blows air through outdoor coil to exchange heat between refrigerant and air. Motors are totally enclosed to increase reliability. This also eliminates need for rain shield.

WARNING

ELECTRICAL SHOCK HAZARD

Failure to follow this warning could result in personal injury or death. Turn off all power to unit before servicing or replacing fan motor. Be sure unit main power switch is turned off.

The bearings are permanently lubricated; therefore, no oil ports are provided.

For suspected electrical failures, check for loose or faulty electrical connections, or defective fan-motor capacitor. Fan motor is equipped with thermal overload device in motor windings which may open under adverse operating conditions. Allow time for motor to cool so device can reset. Further checking of motor can be done with an ohmmeter. Set scale on R X 1 position; check for continuity between three leads. Replace motors that show an open circuit in any of the windings. Place 1 lead of ohmmeter on each motor lead. At same time, place other ohmmeter lead on motor case (ground). Replace any motor that shows resistance to ground, signs of arcing, burning, or overheating.

Located above the compressor is a single-speed fan motor and fan. The *CA9 and *CH9 air conditioner and heat pump models use the ECM variable speed fan motor.

The outdoor Integral Control Motor (ECM), is a variable-speed motor which operates from 450 to 850 rpm. The motor is a dc permanent magnet-type motor with the electronic controls integrated into its rear cover. The control package includes a small diode bridge, capacitors, and power switching devices. It converts ac to dc power and switches the dc power to the motor windings on and off at various rates to control the motor speed. The speed at which the motor windings are thus commutated is determined by a pulse width modulated (PWM) signal which is received from the control board on the motor control lines.

The PWM signal is created by turning a DC signal on and off once within a given period of time. The signal on time relative to the signal total period defines the percent of the PWM. For example, if the period is 5 sec and the control power is turned on for 1 sec then off, the signal will remain off for 4 sec before turning on again to start the next cycle. The PWM is called a 20 percent duty cycle signal. If the on time is increased to 4 sec of the 5 sec period, the PWM is called an 80 percent duty cycle. The ECM reads the PWM signal and increases the motor speed linearly from minimum speed to maximum speed with the percent duty cycle value of the supplied PWM signal.

Outdoor Fan Motor Operation

There are two different types of motors used in the Communicating 2-stage outdoor units. The *CH6 models use a PSC type fan motor, and the speed does not change between high and low speed operation.

On *CH9 models, an ECM fan motor is used to achieve higher efficiency ratings of the system. The outdoor unit control energizes outdoor fan anytime compressor is operating, except for defrost or low-ambient cooling. The outdoor fan remains energized if a pressure switch or compressor overload should open. The outdoor fan motor will continue to operate for one minute after the compressor shuts off when the outdoor ambient is greater than or equal to 100°F/37.7°C. This reduces pressure differential for easier starting on next cycle. On *CA7 and *CH6 models, the outdoor fan remains energized during the 1-minute compressor staging time delay.

On *CA7 and *CH6 models, the outdoor fan motor is a PSC type. A fan relay on the control board turns the fan off and on by opening and

closing a high voltage circuit to the motor. It does not change speeds between low and high stage operation.

On *CA9 and *CH9 models, the outdoor fan is an ECM type. The motor control is continuously powered with high voltage. The motor speed is determined by electrical pulses provided by the PWM outputs on the control board. The ECM motor RPM adjusts to outdoor conditions as described

in Table 15. The PWM output can be measured with a volt meter set to DC volts.

In low ambient cooling (below 55°F/12.7°C), the control board cycles the fan off and on.

**Table 15 – Outdoor Fan Motor PWM
Outdoor Temp (DC volts, Tolerance +/- 2%)**

Model	Low Stage	High Stage	Low & High Stage
	(OAT)104°F / 40°C	(OAT)104°F / 40°C	(OAT)104°F / 40°C
*CH924	8.72	9.35	11.90
*CH936	9.06	10.23	11.90
*CH948	9.91	11.04	11.90
*CH960	10.83	11.70	11.90
*CA924	9.57	10.88	11.90
*CA936	9.06	10.23	11.90
*CA948	9.91	11.04	11.90
*CA960	10.83	11.70	11.90

NOTE: For *CH9 models in low-ambient cooling, the PWM output for both high- and low-stage equals the value for low-stage operation below 55°F (12.8°C).

ECM Fan Motor Troubleshooting

If the outdoor fan motor fails to start and run:

- Check the high-voltage supply. The unit need not be running to check high voltage, but the power must be on.
- If the 230vac is present, use Table 15 to check for proper control voltage output to the fan motor from the control board. The control board sends DC voltage signals to the motor through the terminals labeled PWM1 and PWM2 Set a voltmeter on a DC voltage scale and check across these terminals.
- First check voltage with the motor disconnected. If no control voltage is present, check control-board connections. If connections are good, replace the control board.
- If voltage is present, reconnect the motor and check again. Shut down the unit to reconnect the motor and restart the unit to complete this troubleshooting procedure. If control voltage is no longer present or motor fails to respond, check motor connections.
- If connections are good, replace the motor.

Time Delays

The unit time delays include:

- Five minute time delay to start cooling or heating operation when there is a call from the thermostat or wall control. To bypass this feature, momentarily short and release Forced Defrost pins. Speed up is also possible by pressing the Cool To or Heat To button on the Communicating wall control.
- Five minute compressor re-cycle delay on return from a brown-out condition.
- Two minute time delay to return to standby operation from last valid communication (with Communicating only).
- One minute time delay of outdoor fan at termination of cooling mode when outdoor ambient is greater than or equal to 100°F / 37.78°C.
- Fifteen second delay at termination of defrost before the auxiliary heat (W1) is de-energized.
- Twenty second delay at termination of defrost before the outdoor fan is energized.
- Thirty second compressor delay when quiet shift enabled.
- Seventy and sixty second compressor delays when Quiet Shift-2 is enabled.
- On *CH6 models there is a 1 minute time delay between staging from low to high and from high to low capacity. On *CH6 models there is no delay; the compressor will change from low to high and from high to low capacity “on the fly” to meet the demand.

Pressure Switches

The R-410A two-stage air conditioner contains two pressure switches to prevent system operation if the pressures get excessively high or low. The air conditioner low pressure switch in the suction line opens at 50 PSI and closes at 95 PSI. The high pressure switch opens at 670 PSI and closes at 470 PSI. Both pressure switch settings are considerably higher than on comparably sized R-22 units. The high and low pressure switches can be identified by their pink stripe on the switch’s electrical wires.

The R-410A two-stage heat pump contains a loss of charge switch in the suction line on the *CH6 and *CH9, and in the liquid line on *CH6 models which opens at 23 PSI and closes at 55 PSI. See troubleshooting section for sequence when a pressure switch trip occurs.

Muffler, Accumulator, Reversing Valve (RVS)

The R-410A two-stage air conditioners and heat pumps have a compressor discharge line muffler, to dampen sound pressure pulsations.

The R-410A two-stage heat pumps have a specifically designed reversing valve, for R-410A application and an accumulator for storing excess liquid refrigerant during the heating mode to prevent damaging flood-back.

Thermistors

Outdoor Ambient Thermistor

The R-410A two-speed air conditioner and heat pump units have an outdoor ambient air thermistor. The control board must know the outdoor air temperature so it can activate various functions (See Fig. 47). These functions include:

- Activating the compressor crankcase heater when ever the outdoor unit is in the off cycle.
- The fan motor speed changes for both air conditioner and heat pump on the ECM equipped units.

Outdoor Coil Thermistor (OCT)

The coil or defrost thermistor (See Figure 48) is the same thermistor used to monitor outdoor air temperature, but used in a different configuration. The control board must know the coil temperature so it can activate various functions. These functions include:

- Frost sensing on heat pumps
- Coil-vs-Ambient temperature relationship
- Low ambient cooling operation

Thermistor Curve

The resistance vs. temperature chart enables the service technicians to check thermistor resistance, regardless of the temperature.

For example, at a 0°F / 15.6°C temperature, thermistor resistance should be around 16,000 Ohms. (See Fig. 44.)

We will talk about the thermistor in more detail when we review the control board fault codes.

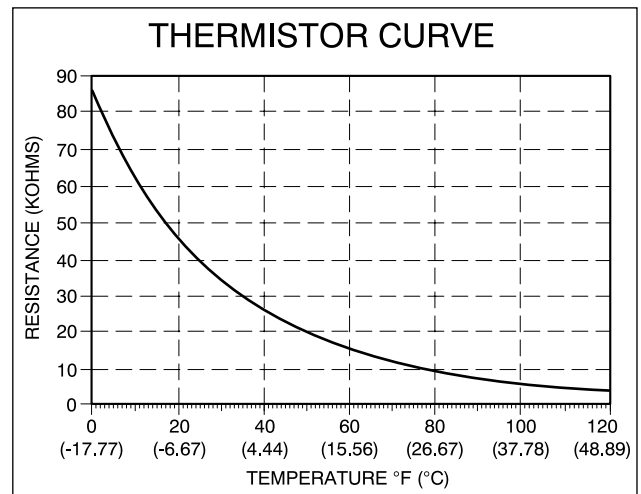

Fig. 44 – Resistance Values Versus Temperature

A08054

Control Box

Contactor And Capacitor

Removal of the control box cover exposes the control components. Both air conditioner and heat pump control boxes will appear to be nearly identical. There are two contactors, two capacitors, a control board and a compressor start assist. The contactors are identical to those used in the standard single speed units. One controls low capacity operation and the second controls high speed. The capacitors also are similar to those used in standard single speed units. You have a fan capacitor for the outdoor fan motor, and a run capacitor for the compressor motor. The control board, start capacitor, and start relay control the starting of the compressor. Always replace these devices with the Factory Approved Components.

Incoming Power

! WARNING

ELECTRICAL SHOCK HAZARD

Failure to follow this warning could result in personal injury or death. The outdoor unit must always be grounded through the ground lug to the unit disconnect and from the disconnect to the electrical fuse box.

NOTE: ECM motors are not connected to a capacitor.

Incoming power is attached to the two power wire stripped leads. A ground lug is also provided.

- First check that the model plug is correct for the unit model and size, and that it is installed properly.

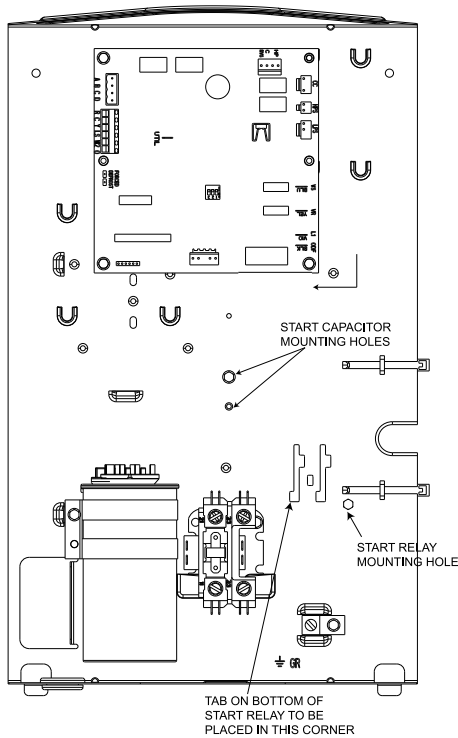

Fig. 45 – Start Relay and Capacitor Mounting Locations A10157
Communicating in Cube Cabinet

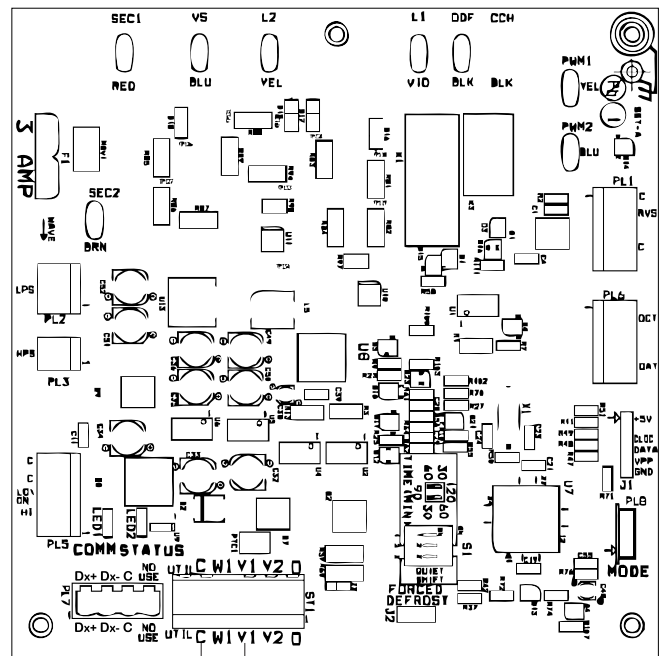
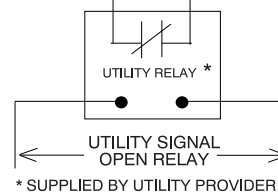
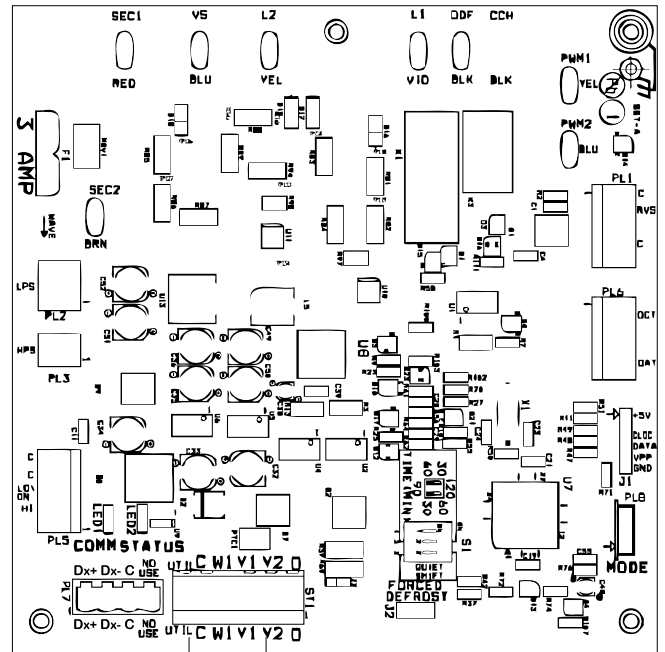

Fig. 46 – 2-Stage Control Board A150063

TROUBLESHOOTING

Troubleshooting circuit board FAST # 1185237, 1186140

The Communicating Series outdoor units all use the same control board. A model plug is used to identify the system type, and set the operating parameters for airflow, start circuit timing etc. (See Model Plug section.)

Replacement boards may have a different part number from the original board. A newer board will always be backward compatible to previous units if it is superseded at Fast Parts. Old boards are not always forward compatible due to new functions, or software changes made to resolve field issues.

Systems Communication Failure

If communication with the Communicating control is lost with the wall control, the control will flash the appropriate fault code. (See Table 17.) Check the wiring to the wall control and the indoor and outdoor units.

Pressure Switch Protection

The outdoor unit is equipped with high- and low-pressure switches. If the control senses the opening of a high- or low-pressure switch, it will respond as follows:

1. De-energize the appropriate compressor contactor.
2. Keep the outdoor fan operating for 15 minutes.
3. Display the appropriate fault code (see Table 17).
4. After a 15 minute delay, if there is a call for cooling or heating and LPS or HPS is reset, the appropriate compressor contactor is energized.
5. If LPS or HPS has not closed after a 15 minute delay, the outdoor fan is turned off. If the open switch closes anytime after the 15 minute delay, then resume operation with a call for cooling or heating.
6. If LPS or HPS trips 3 consecutive cycles, the unit operation is locked out for 4 hours.
7. In the event of a high-pressure switch trip or high-pressure lockout, check the refrigerant charge, outdoor fan operation, and outdoor coil (in cooling) for airflow restrictions, or indoor airflow in heating.
8. In the event of a low-pressure switch trip or low-pressure lockout, check the refrigerant charge and indoor airflow (cooling) and outdoor fan operation and outdoor coil in heating.

Control Fault

If the outdoor unit control board has failed, the control will flash the appropriate fault code (see Table 17). The control board should be replaced.

Brown-Out Protection

If the line voltage is less than 187v for at least 4 seconds, the appropriate compressor contactor and fan relay are de-energized. Compressor and fan operation are not allowed until voltage is a minimum of 190v. The control will flash the appropriate fault code (see Table 17).

230v Brown-Out Protection Defeated

The brownout feature can be defeated if needed for severe noisy power conditions. This defeat should always be a last resort to solving the problem. Defeat is available for Communicating systems on the wall control or outside board, or it can be initiated through the forced defrost pins for non-communicating systems as follows:

The brownout toggle is accomplished by shorting the defrost pins from power up with the OAT and OCT sensor connector removed. After 3 seconds, the status of the force defrost short and the OAT/OCT as open will be checked. If correct, then the brownout will be toggled.

- Status code 6 shows the brownout is disabled.
- Status code 5 shows the brownout is active.

After the brownout defeat is set, power down and reinstall the OAT/OCT sensor and remove the short from the forced defrost pins. As long as the short on the forced defrost remains, the OAT and OCT faults will not be cleared. The code will continue to be flashed.

The control is shipped with the brownout active. The change in status is remembered until toggled to a new status. A power down/power up sequence will not reset the status. It may be necessary to do the toggle twice to cycle to the desired state of the defeat.

230V Line (Power Disconnect) Detection

If there is no 230v at the compressor contactor(s) when the indoor unit is powered and cooling or heating demand exists, the appropriate fault code is displayed. Verify the disconnect is closed and 230v wiring is connected to the unit.

Compressor Voltage Sensing

The control board input terminals labeled VS, and L2 on *CA7, *CA9, *CH6, and *CH9 models (see Fig. 46) are used to detect compressor voltage status and alert the user of potential problems. The control continuously monitors the high voltage on the run capacitor of the compressor motor. Voltage should be present any time the compressor contactor is energized and voltage should not be present when the contactor is de-energized.

Contactors Shorted Detection

If there is compressor voltage sensed when there is no demand for compressor operation, the contactor may be stuck closed or there may be a wiring error. The control will flash the appropriate fault code.

Compressor Thermal Cutout - *CA7, *CA9, *CH6, *CH9

If the control senses the compressor voltage after start-up and is then absent for 10 consecutive seconds while cooling or heating demand exists, the thermal protector is open. The control de-energizes the compressor contactor for 15 minutes, but continues to operate the outdoor fan. The control Status LED will flash the appropriate code shown in Table 17. After 15 minutes, with a call for low or high stage cooling or heating, the compressor contactor is energized. If the thermal protector has not re-set, the outdoor fan is turned off. If the call for cooling or heating continues, the control will energize the compressor contactor every 15 minutes. If the thermal protector closes, (at the next 15 minute interval check) the unit will resume operation.

If the thermal cutout trips for three consecutive cycles, then unit operation is locked out for 4 hours and the appropriate fault code is displayed.

Low or High Contactor Open / No 230V at Compressor Contactor - *CA7, *CA9, *CH6, *CH9

If the compressor voltage is not sensed when the compressor should be starting, the appropriate contactor may be stuck open or there is a wiring error. The control will flash the appropriate fault code. Check the contactor and control box wiring.

Troubleshooting units for proper switching between low & high stages - *CA7, *CA9, *CH6, *CH9

Check the suction pressures at the service valves. Suction pressure should be reduced by 3-10% when switching from low to high capacity.

NOTE: The liquid pressures are very similar between low and high stage operation, so liquid pressure should not be used for troubleshooting.

Compressor current should increase 20-45% when switching from low to high stage. The compressor solenoid when energized in high stage, should measure 24vac.

When the compressor is operating in low stage the 24v DC compressor solenoid coil is de-energized. When the compressor is operating in high stage, the 24v DC solenoid coil is energized. The solenoid plug harness that is connected to the compressor HAS an internal rectifier that converts the 24v AC signal to 24v DC. **DO NOT INSTALL A PLUG WITHOUT AN INTERNAL RECTIFIER.**

Unloader Test Procedure - *CA7, *CA9, *CH6, *CH9

The unloader is the compressor internal mechanism, controlled by the DC solenoid, that modulates between high and low stage. If it is suspected that the unloader is not working, the following methods may be used to verify operation.

1. Operate the system and measure compressor amperage. Cycle the unloader on and off at 30 second plus intervals at the UI (from low to high stage and back to low stage). Wait 5 seconds after staging to high before taking a reading. The compressor amperage should go up or down at least 20 percent.
2. If the expected result is not achieved, remove the solenoid plug from the compressor and with the unit running and the UI calling for high stage, test the voltage output at the plug with a DC voltmeter. The reading should be 24 volts DC.
3. If the correct DC voltage is at the control circuit molded plug, measure the compressor unloader coil resistance. The resistance should be approximately 330 or 1640 ohms depending on unloader coil supplier. If the coil resistance is infinite or is grounded, the compressor must be replaced.

Temperature Thermistors

Thermistors are electronic devices which sense temperature. As the temperature increases, the resistance decreases. Thermistors are used to sense outdoor air (OAT) and coil temperature (OCT). Refer to Fig. 44 for resistance values versus temperature.

If the outdoor air or coil thermistor should fail, the control will flash the appropriate fault code. (See Table 17)

IMPORTANT: The outdoor air thermistor and coil thermistor should be factory mounted in the final locations. Check to ensure thermistors are mounted properly per Fig. 47 and Fig. 48.

Thermistor Sensor Comparison

The control continuously monitors and compares the outdoor air temperature sensor and outdoor coil temperature sensor to ensure proper operating conditions. The comparison is:

- In cooling if the outdoor air sensor indicates } 10°F warmer than the coil sensor (or) the outdoor air sensor indicates } 20°F cooler than the coil sensor, the sensors are out of range.
- In heating if the outdoor air sensor indicates } 35°F warmer than the coil sensor (or) the outdoor air sensor indicates } 10°F cooler than the coil sensor, the sensors are out of range.

If the sensors are out of range, the control will flash the appropriate fault code as shown in Table 17.

The thermistor comparison is not performed during low ambient cooling or defrost operation.

Failed Thermistor Default Operation

Factory defaults have been provided in the event of failure of outdoor air thermistor (OAT) and/or outdoor coil thermistor (OCT).

If the OAT sensor should fail, low ambient cooling will not be allowed and the one-minute outdoor fan off delay will not occur. Defrost will be initiated based on coil temperature and time.

If the OCT sensor should fail, low ambient cooling will not be allowed. Defrost will occur at each time interval during heating operation, but will terminate after 5 minutes.

If there is a thermistor out of range error, defrost will occur at each time interval during heating operation, but will terminate after 5 minutes.

Count the number of short and long flashes to determine the appropriate flash code. Table 17 gives possible causes and actions related to each error.

OAT Thermistor must be locked in place with spherical nib end facing towards the front of the control box

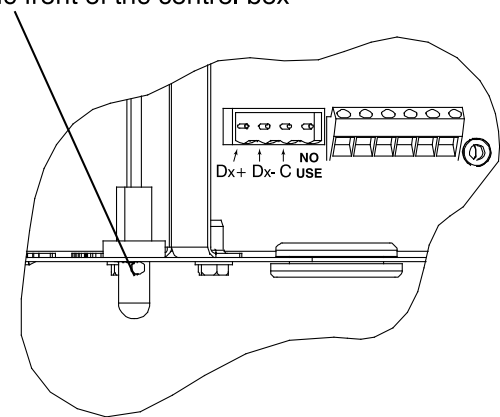
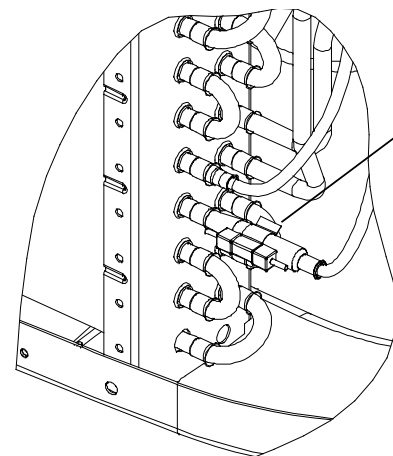

Fig. 47 – Outdoor Air Thermistor (OAT) Attachment

A150065



OCT Thermistor must be secured tight on stub tube.

Fig. 48 – Outdoor Coil Thermistor (OCT) Attachment

A05408

**Table 16 – Two-Stage Compressor Resistances
(Winding Resistance at 70°F ±20°)**

Winding	024	036	048	060
Start (S-C)	1.64	1.52	1.86	1.63
Run (R-C)	1.30	0.88	0.52	0.39

Status Codes

Table 17 shows the status codes flashed by the amber status light. Most system problems can be diagnosed by reading the status code as flashed by the amber status light on the control board.

The codes are flashed by a series of short and long flashes of the status light. The short flashes indicate the first digit in the status code, followed by long flashes indicating the second digit of the error code.

The short flash is 0.25 seconds ON and the long flash is 1.0 second ON. Time between flashes is 0.25 seconds. Time between short flash and first long flash is 1.0 second. Time between code repeating is 2.5 seconds with LED OFF.

EXAMPLE:

3 short flashes followed by 2 long flashes indicates a 32 code. Table 17 shows this to be low pressure switch open.

Table 17 – TROUBLESHOOTING

OPERATION	FAULT	AMBER LED FLASH CODE	POSSIBLE CAUSE AND ACTION
Standby – no call for unit operation	None	On solid, no flash	Normal operation
Low Stage Cool/Heat Operation	None	1, pause	Normal operation
High Stage Cool/Heat Operation	None	2, pause	Normal operation
Brown out protection is Disabled	None	5, pause	User made selection, see instructions for more detail
Brown out protection is Active	None	6, Pause	User made selection, see instructions for more detail
	System Communications Failure	16	Communication with wall control lost. Check wiring to wall control, indoor and outdoor units
	Invalid Model Plug	25	Control does not detect a model plug or detects an invalid model plug. Unit will not operate without correct model plug.
	High Pressure Switch or Discharge Temp Switch Open	31*	High-pressure switch trip. Check refrigerant charge, outdoor fan operation and coils for airflow restrictions.
	Low Pressure Switch Open	32*	Low-pressure switch trip. Check refrigerant charge and indoor air flow.
	Control Fault	45	Outdoor unit control board has failed. Control board needs to be replaced.
	Brown Out (230 v)	46	Line voltage < 187v for at least 4 seconds. Compressor and fan operation not allowed until voltage ≥ 190v. Verify line voltage.
	No 230v at Unit	47	There is no 230v at the contactor when indoor unit is powered and cooling/heating demand exists. Verify the disconnect is closed and 230v wiring is connected to the unit.
	Outdoor Air Temp Sensor Fault	53	Outdoor air sensor not reading or out of range. Ohm out sensor and check wiring.
	Outdoor Coil Sensor Fault	55	Coil sensor not reading or out of range. Ohm out sensor and check wiring.
	Thermistors out of range	56	Improper relationship between coil sensor and outdoor air sensor. Ohm out sensors and check wiring.
	Low Stage Thermal Cutout	71*	Compressor operation detected then disappears while low stage demand exists. Possible causes are internal compressor overload trip or start relay and capacitor held in circuit too long (if installed).
	High Stage Thermal Cutout	72*	Compressor operation detected then disappears while high stage demand exists. Possible causes are internal compressor overload trip or start relay and capacitor held in circuit too long (if installed).
	Contactor Shorted	73	Compressor voltage sensed when no demand for compressor operation exists. Contactor may be stuck closed or there is a wiring error.
	No 230V at Compressor	74	Compressor voltage not sensed when compressor should be starting. Contactor may be stuck open or there is a wiring error.
	Low Stage Thermal Lockout	81	Thermal cutout occurs in three consecutive low/high stage cycles. Low stage locked out for 4 hours or until 24v power recycled.
	High Stage Thermal Lockout	82	Thermal cutout occurs in three consecutive high/low stage cycles. High stage locked out for 4 hours or until 24v power recycled.
	Low-Pressure Lockout	83	Low pressure switch trip has occurred during 3 consecutive cycles. Unit operation locked out for 4 hours or until 24v power recycled.
	High-Pressure Lockout	84	High pressure switch trip has occurred during 3 consecutive cycles. Unit operation locked out for 4 hours or until 24v power recycled.

*. Sequence: Compressor contactor is de-energized and outdoor fan is energized for up to 15 minutes. If demand still exists, control will energize compressor contactor after 15 minute delay. If fault is cleared, unit will resume operation. If fault still exists, fan shuts off, and error code continues to flash. Control will attempt re-start every 15 minutes. Cycling low voltage defeats the 15 minute delay.

CARE AND MAINTENANCE

To assure high performance and minimize possible equipment malfunction, it is essential that maintenance be performed periodically on this equipment. The frequency with which maintenance is performed is dependent on such factors as hours of operation, geographic location, and local environmental conditions.

WARNING

ELECTRICAL SHOCK HAZARD

Failure to follow this warning could result in personal injury or death. Disconnect all electrical power to unit before performing any maintenance or service on outdoor unit. Remember to disconnect power supply to air handler as this unit supplies low-voltage power to the outdoor unit.

The minimum maintenance that should be performed on this equipment is as follows:

1. Check outdoor coil for cleanliness each heating and cooling season and clean as necessary.
2. Check fan motor and blade for cleanliness each month during cooling season and clean as necessary.
3. Check electrical connections for tightness and controls for proper operation each cooling season and service as necessary.

CAUTION

UNIT DAMAGE HAZARD

Failure to follow this caution may result in equipment damage or improper operation.

Because of possible damage to the equipment or personal injury, maintenance should be performed by qualified personnel only.

Desert and Seacoast Locations

Special consideration must be given to installation and maintenance of condensing units installed in coastal or desert locations. This is because salt and alkali content of sand adheres to aluminum fins of coil and can cause premature coil failure due to corrosion.

Preventive measures can be taken during installations, such as:

4. Locate unit on side of structure opposite prevailing winds.
5. Elevate unit to height where drifting sand cannot pile up against coil. Mounting feet, 4 in. high, are available as accessories and can be used to elevate unit.
6. Addition of coastal filter (See Product Specifications accessory listing).

Maintenance in desert and seacoast locations:

1. Frequent inspection of coil and basepan especially after storms and/or high winds.
2. Clean coil by flushing out sand from between coil fins and out of basepan as frequently as inspection determines necessary.
3. In off season, cover with covering that allows air to circulate through but prevents sand from sifting in (such as canvas material). Do not use plastic as plastic will hold moisture possibly causing corrosion.

Cleaning Coil

CAUTION

UNIT DAMAGE HAZARD

Failure to follow this caution may result in equipment damage or improper operation.

Coil fin damage can result in higher operating costs or compressor damage. Do not use flame, high-pressure water, steam, volatile or corrosive cleaners on fins or tubing.

1. Clean coil using vacuum cleaner and its crevice tool. Move crevice tool vertically, close to area being cleaned, making sure tool touches only dirt on fins and not fins. To prevent fin damage, do not scrub fins with tool or move tool horizontally against fins.
2. If oil deposits are present, spray coil with ordinary household detergent. Wait 10 minutes, and proceed to next step.
3. Using garden hose, spray coil vertically downward with constant stream of water at moderate pressure. Keep nozzle at a 15- to 20° angle, about 3 in. from coil face and 18 in. from tube. Spray so debris is washed out of coil and basepan.
4. Reinstall top cover and position blade.
5. Reconnect electrical power and check for proper operation.

Cleaning Outdoor Fan Motor and Blade

1. Remove fan motor and blade. Be careful not to bend or dent fan blade.
2. Clean motor and blade with soft brush or cloth. Be careful not to disturb balance weights on fan blade.
3. Check fan blade setscrew for tightness.
4. Reinstall fan motor and blade to top cover and check for alignment.
5. Reinstall top cover and position blade.
6. Reconnect electrical power and check for proper operation.

Electrical Controls and Wiring

1. Disconnect power to both outdoor and indoor units.
2. Check all electrical connections for tightness. Tighten all screws on electrical connections. If any connections appear to be burned or smoky, disassemble the connection, clean all parts and stripped wires, and reassemble. Use a new connector if old one is burned or corroded, and crimp tightly.
3. Reconnect electrical power to indoor and outdoor units and observe unit through 1 complete operating cycle.
4. If there are any discrepancies in operating cycle, troubleshoot to find cause and correct.

Refrigerant Circuit

1. Check refrigerant charge using the superheat method, and if low on charge, check unit for leaks using an electronic leak detector.
2. If any leaks are found, remove and reclaim or isolate charge (pumpdown) if applicable. Make necessary repairs.
3. Evacuate, recharge, and observe unit through 1 complete operating cycle.

Final Check-Out

After the unit has been operating, the following items should be checked.

1. Check that unit operational noise is not excessive due to vibration of component, tubing, panels, etc. If present, isolate problem and correct.
2. Check to be sure caps are installed on service valves and are tight.
3. Check to be sure tools, loose parts, and debris are removed from unit.
4. Check to be sure all panels and screws are in place and tight.

AIR CONDITIONER TROUBLESHOOTING CHART

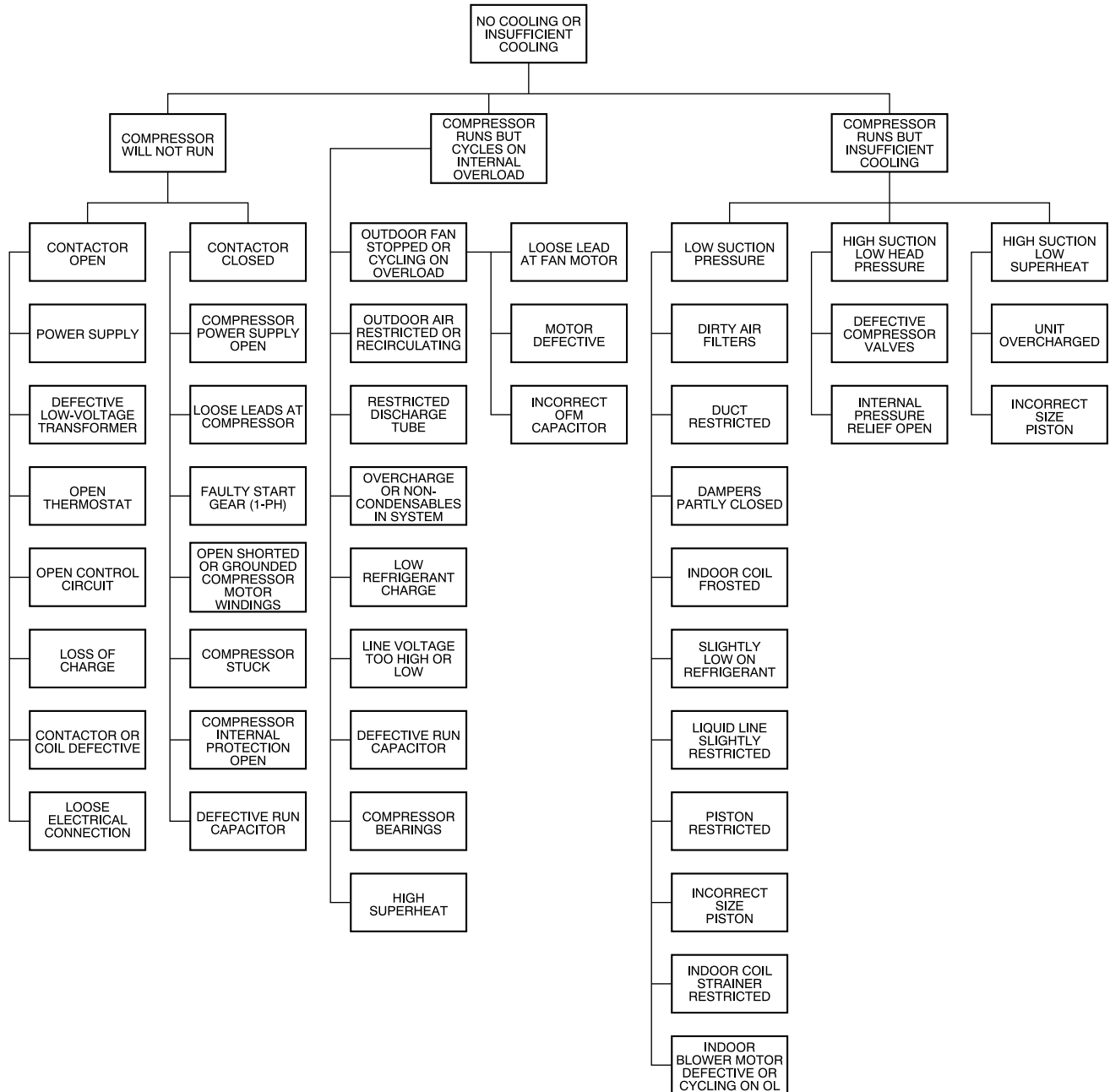

Fig. 49 – Air Conditioner Troubleshooting Chart

A90208

HEAT PUMP TROUBLESHOOTING HEATING CYCLE

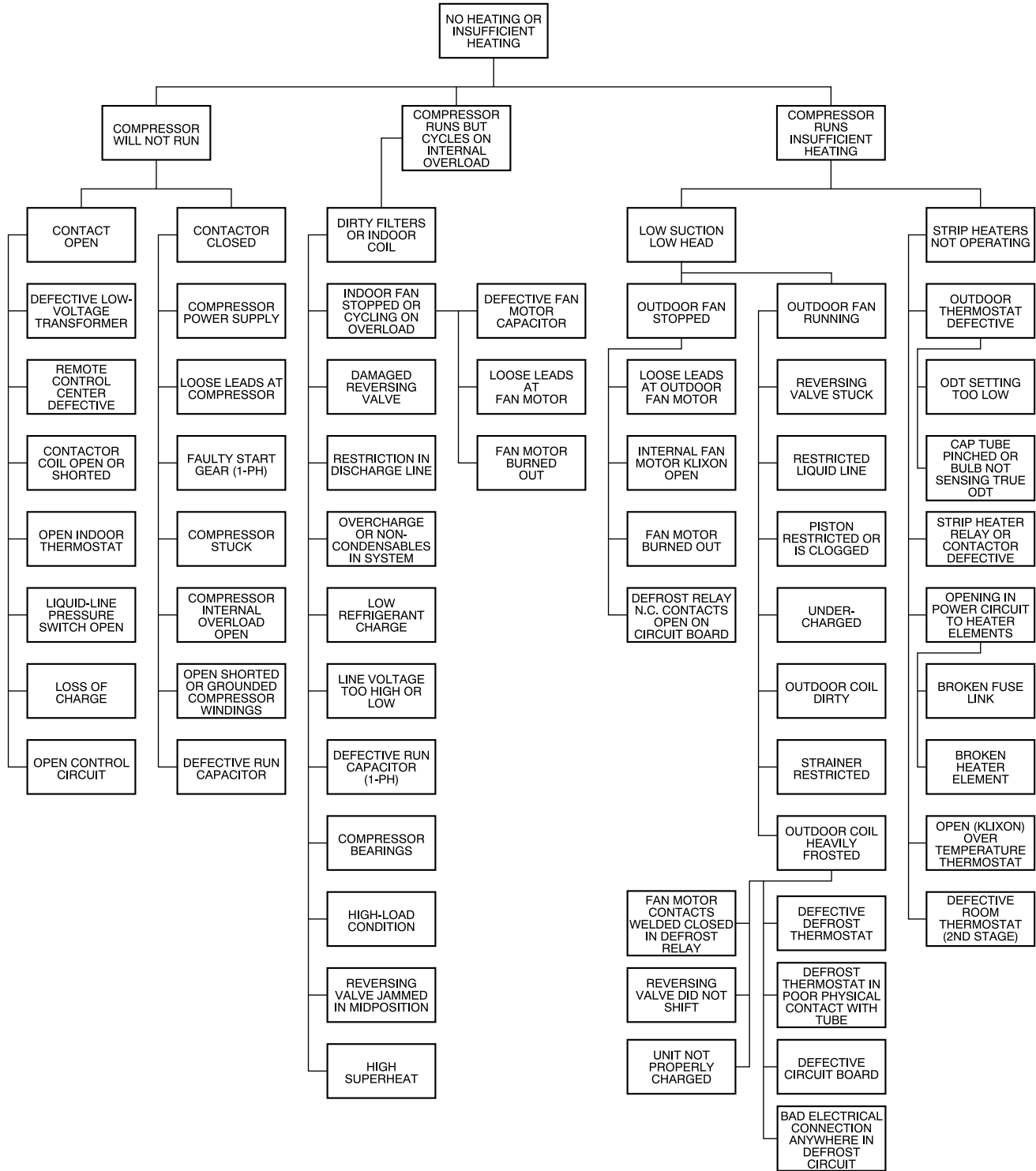

Fig. 50 – Heat Pump Troubleshooting - Heating Cycle

A90206

HEAT PUMP TROUBLESHOOTING COOLING CYCLE

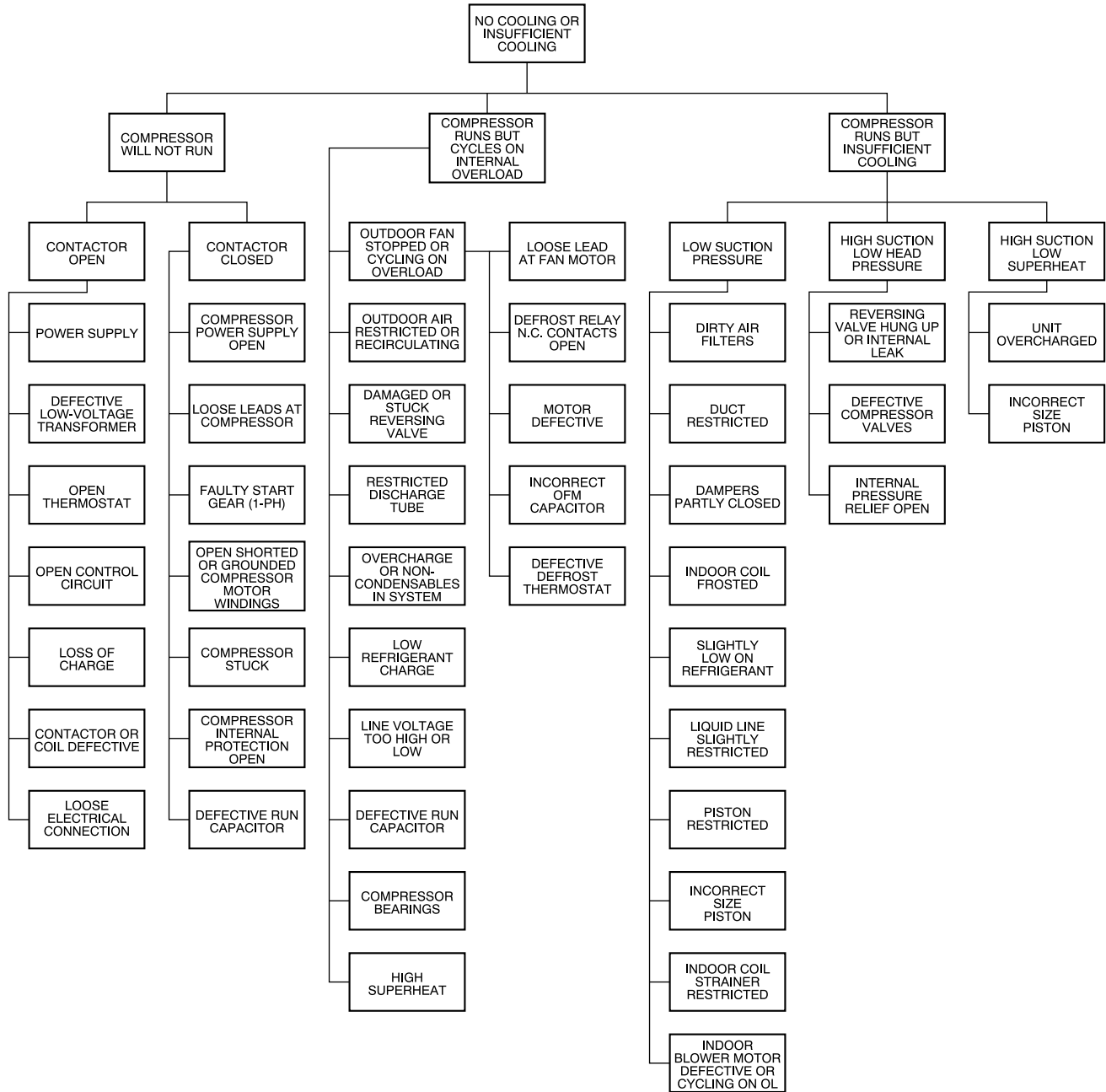

Fig. 51 – Heat Pump Troubleshooting - Cooling Cycle

A90207

INDEX OF TABLES

Air Conditioner and Heat Pump Model Number Nomenclature	2
Defrost Control Speed-Up Timing Sequence	12
ECM Fan Motor Wires	14
Fitting Losses in Equivalent Feet.....	30
R-410A System Suction Pressure Drop.....	31
R-22 System Suction Pressure Drop.....	32
R-410A Refrigerant Pressure Temperature Chart.....	33
R-22 Refrigerant Pressure Temperature Relationship	34
Puron Subcooling Chart.....	35
R-410A Superheat Chart.....	36
R-22 Subcooling Chart	37
R-22 Superheat Chart.....	37
Status Codes.....	46
Model Plug Information.....	50
Outdoor Fan Motor PWM Outdoor Temp (DC volts, Tolerance +/- 2%).....	53
Two-Stage Compressor Resistances (Winding Resistance at 70°F ±20°).....	58
TROUBLESHOOTING.....	58