

NFBUP-S Damper Actuator Technical Data Sheet

On/Off, Spring Return, AC 24...240 V



Technical Data

Power Supply	24...240 VAC, -20% / +10%, 50/60 Hz, 24...125 VDC, ±10%
Power consumption in operation	6 W
Power consumption in rest position	2.5 W
Transformer sizing	6 VA @ AC 24 V (class 2 power source), 6.5 VA @ AC 120 V, 9.5 VA @ AC 240 V
Shaft Diameter	1/2...1.05" round, centers on 1/2" and 3/4" with insert, 1.05" without insert
Electrical Connection	(2) 18 GA appliance cables with 1/2" conduit connectors, 3 ft [1 m],
Overload Protection	electronic throughout 0...95° rotation
Electrical Protection	actuators are double insulated
Angle of rotation	95°, adjustable with mechanical end stop, 35...95°
Torque motor	90 in-lb [10 Nm]
Direction of motion motor	selectable by ccw/cw mounting
Direction of motion fail-safe	reversible with cw/ccw mounting
Position indication	Mechanical
Manual override	5 mm hex crank (3/16" Allen), supplied
Running Time (Motor)	75 s
Running time fail-safe	<20 s @ -4...122°F [-20...50°C], <60 s @ -22°F [-30°C]
Ambient humidity	max. 95% r.H., non-condensing
Ambient temperature	-22...122°F [-30...50°C]
Storage temperature	-40...176°F [-40...80°C]
Degree of Protection	IP54, NEMA 2, UL Enclosure Type 2
Housing material	Galvanized steel and plastic housing
Agency Listing	cULus acc. to UL60730-1A/-2-14, CAN/CSA E60730-1:02, CE acc. to 2014/30/EU and 2014/35/EU
Noise level, motor	50 dB(A)
Noise level, fail-safe	62 dB(A)
Servicing	maintenance-free
Quality Standard	ISO 9001
Weight	5.3 lb [2.4 kg]
Auxiliary switch	2 x SPDT, 3 A resistive (0.5 A inductive) @ AC 250 V, one set at 10°, one adjustable 10...90°

†Rated Impulse Voltage 4kV, Type of Action 1.AA.B, Control Pollution Degree 3.

Torque min. 90 in-lb, for control of air dampers.

Application

For On/Off, fail-safe control of dampers in HVAC systems. Actuator sizing should be done in accordance with the damper manufacturer's specifications. Control is On/Off from an auxiliary contact or a manual switch. The actuator is mounted directly to a damper shaft up to 1.05" in diameter by means of its universal clamp. A crank arm and several mounting brackets are available for applications where the actuator cannot be direct coupled to the damper shaft.

Operation

The NF.UP-S series actuators provide true spring return operation for reliable failsafe application and positive close off on air tight dampers. The spring return system provides constant torque to the damper with, and without, power applied to the actuator. The NF.UP-S series provides 95° of rotation and is provided with a graduated position indicator showing 0° to 95°. The actuator may be stalled anywhere in its normal rotation without the need of mechanical end switches. The NF.UP-S versions are provided with two built-in auxiliary switches. These SPDT switches provide safety interfacing or signaling, for example, for fan startup. The switching function at the fail-safe position is fixed at 10°, the other switch function is adjustable between 10° to 90°. The NF.UP-S actuator is shipped at 5° (5° from full fail-safe) to provide automatic compression against damper gaskets for tight shut-off.

Dimensions (Inches[mm])

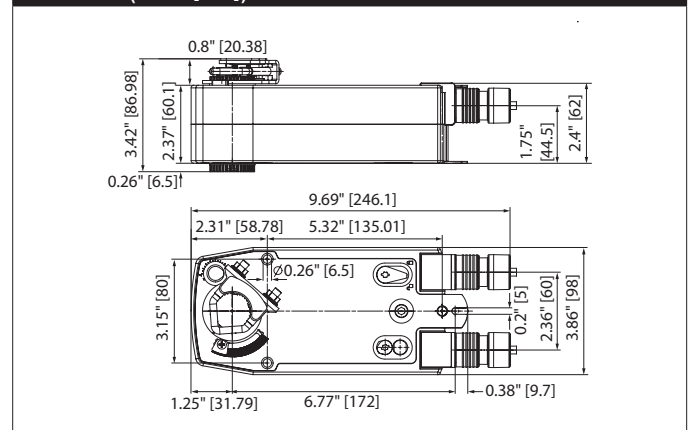

Accessories	
AF-P	Anti-rotation bracket AF/NF.
AV8-25	Shaft extension
IND-AFB	End stop indicator
K7-2	Shaft clamp reversible
KG10A	Ball joint
KG8	Ball joint
KH10	Damper crank arm
KH8	Damper crank arm
KH-AFB	Actuator arm
SH10	Push rod for KG10A ball joint (36" L, 3/8" diameter).
SH8	Push rod for KG6 & KG8 ball joints (36" L, 5/16" diameter).
TOOL-06	8 mm and 10 mm wrench.
ZG-100	Univ. right angle bracket 17"x11-1/8"x6" (HxWxbase).
ZG-101	Univ. right angle bracket 13x11x7-7/16" (HxWxbase).
ZG-109	Right angle bracket for ZS-260.
ZG-110	Stand-off bracket for ZS-260.
ZG-118	AFB(X)/NFB(X) U bracket 5-7/8x5-1/2x2-19/32" (HxWxD).
ZG-120	Jackshaft mounting bracket.
ZG-AFB	Mounting kit for linkage operation
ZG-AFB118	AFB(X)/NFB(X) crankarm adaptor kit.
ZG-DC1	Damper clip for damper blade, 3.5" width.
ZG-DC2	Damper clip for damper blade, 6" width.
ZG-JSA-1	1" diameter jackshaft adaptor (11" L).
ZG-JSA-2	1-5/16" diameter jackshaft adaptor (12" L).
ZG-JSA-3	1.05" diameter jackshaft adaptor (12" L).
ZS-100	Weather shield - galvaneal 13x8x6" (LxWxD).
ZS-101	Base plate for ZS-100.
ZS-150	Weather shield - PC w/ foam seal 16x8-3/8x4" (LxWxD).
ZS-260	Explosion proof housing.
ZS-300	NEMA 4X, 304 stainless steel enclosure.
ZS-300-5	NEMA 4X, 316L stainless steel enclosure.
ZS-300-C1	1/2" shaft adaptor, standard with ZS-300(-5).
ZS-300-C2	3/4" shaft adaptor for ZS-300(-5).
ZS-300-C3	1" shaft adaptor for ZS-300(-5).
Z-SF	Base plate extension
P475	Shaft mount, non-Mercury aux. switch for 1/2" dia. shafts.
P475-1	Shaft mount, non-Mercury aux. switch for 1" dia. shafts.
PS-100	Low voltage and control signal simulator.
TF-CC US	Cable conduit connector, 1/2".

Typical Specification

On/Off spring return damper actuators shall be direct coupled type which require no crank arm and linkage and be capable of direct mounting to a jackshaft up to a 1.05" diameter. The actuators must be designed so that they may be used for either clockwise or counter clockwise fail-safe operation. Actuators shall be protected from overload at all angles of rotation. If required, two SPDT auxiliary switch shall be provided having the capability of one being adjustable. Actuators with auxiliary switches must be constructed to meet the requirements for Double Insulation so an electrical ground is not required to meet agency listings. Actuators shall be cULus listed and have a 5 year warranty, and be manufactured under ISO 9001 International Quality Control Standards. Actuators shall be as manufactured by Belimo.

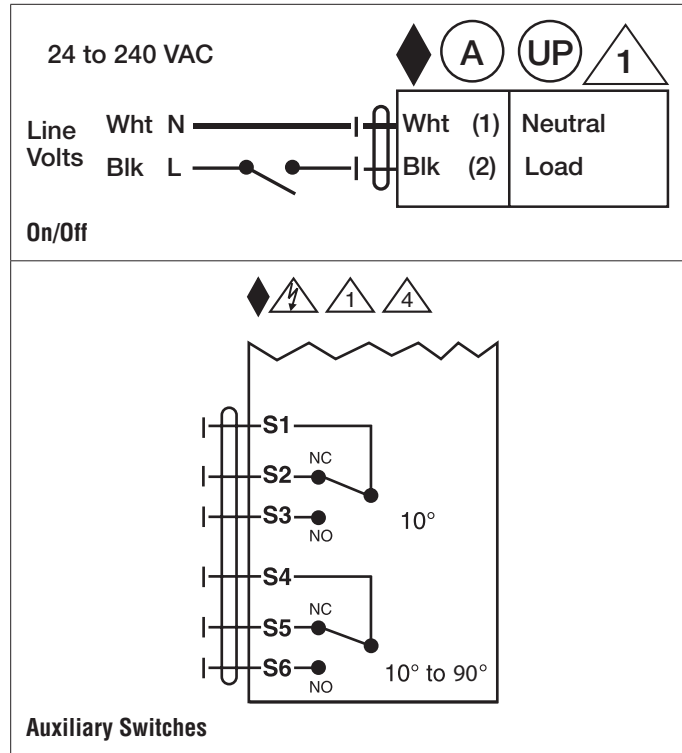

NFBUP-S Damper Actuator Technical Data Sheet

On/Off, Spring Return, AC 24...240 V

Wiring Diagrams



WARNING! LIVE ELECTRICAL COMPONENTS!

During installation, testing, servicing and troubleshooting of this product, it may be necessary to work with live electrical components. Have a qualified licensed electrician or other individual who has been properly trained in handling live electrical components perform these tasks. Failure to follow all electrical safety precautions when exposed to live electrical components could result in death or serious injury.



Meets cULus requirements without the need of an electrical ground connection.



Apply only AC line voltage or only UL-Class 2 voltage to the terminals of auxiliary switches. Mixed or combined operation of line voltage/safety extra low voltage is not allowed.



Actuators with appliance cables are numbered.



Universal Power Supply (UP) models can be supplied with 24 VAC up to 240 VAC, or 24 VDC up to 125 VDC.



Provide overload protection and disconnect as required.



Two built-in auxiliary switches (2x SPDT), for end position indication, interlock control, fan startup, etc.