

## System 350™ P352AB Electronic Pressure Control Series

The P352AB controls are On/Off electronic pressure controls with Single-Pole, Double-Throw (SPDT) relay output and Light-Emitting Diode (LED) indication. The P352AB controls are designed with Reverse or Direct Acting mode of operation, adjustable differential, and an interchangeable pressure transducer. The P352AB control will accept S352A Stage Modules to control stages of Heating, Ventilating, and Air Conditioning (HVAC) and/or refrigeration equipment.

Three models cover the ranges of 0-100 psi, 90-250 psi, and 240-600 psi, covering most common refrigeration and air conditioning applications.

As are all System 350™ products, the P352AB control is housed in a NEMA 1 high-impact thermoplastic enclosure. The modular design provides easy, snap-together connections for quick installation and future expandability.



Figure 1: P352AB Electronic Pressure Control

<b>Features and Benefits</b>	
<input type="checkbox"/> <b>Modular Design</b>	Provides the flexibility to add S352A Stage Modules, D352 Display Module, and Y350R Power Module
<input type="checkbox"/> <b>Plug-together Connectors and 35 mm DIN Rail Mounting</b>	Eliminates wiring between modules and reduces installation costs
<input type="checkbox"/> <b>Three Models Available with Adjustable Setpoint Ranges of 0-100 psi, 90-250 psi, and 240-600 psi</b>	Handles pressures required for most fan cycling and compressor unloading applications
<input type="checkbox"/> <b>Models Available with Adjustable Differential from 2-50 psi and 10-100 psi</b>	Enables user to match the equipment cycle rate and/or sequencing for a given application
<input type="checkbox"/> <b>Field-selectable Direct or Reverse Acting Mode</b>	Energizes relay output on either an increase or a decrease in pressure
<input type="checkbox"/> <b>Interchangeable Pressure Transducer</b>	Increases versatility and serviceability

# Application

The P352AB Electronic Pressure Control can be used as a standalone device or in conjunction with System 350 plug-together accessory modules for single or multiple stage refrigeration and HVAC pressure control applications. Typical applications include:

- condenser fan cycling
- compressor cycling and unloading

**IMPORTANT:** Use this System 350 controls only as an operating control. Where failure or malfunction of the System 350 controls could lead to personal injury or property damage to the controlled equipment or other property, additional precautions must be designed into the control system. Incorporate and maintain other devices, such as supervisory or alarm systems or safety or limit controls, intended to warn of or protect against failure or malfunction of the System 350 controls.

**IMPORTANT:** Utiliser ce System 350 controls uniquement en tant que dispositif de contrôle de fonctionnement. Lorsqu'une défaillance ou un dysfonctionnement du System 350 controls risque de provoquer des blessures ou d'endommager l'équipement contrôlé ou un autre équipement, la conception du système de contrôle doit intégrer des dispositifs de protection supplémentaires. Veiller dans ce cas à intégrer de façon permanente d'autres dispositifs, tels que des systèmes de supervision ou d'alarme, ou des dispositifs de sécurité ou de limitation, ayant une fonction d'avertissement ou de protection en cas de défaillance ou de dysfonctionnement du System 350 controls.

A typical System 350 pressure control setup includes the following:

- P352AB Electronic Pressure Control
- S352A Stage Modules
- D352 Digital Display Module
- Y350R Power Module (or 24 VAC transformer)
- P399 Electronic Pressure Transducer

# Operation

The P352AB Electronic Pressure Control operates on 24 VAC and has an SPDT relay output. A front panel LED lights to indicate when the relay is energized.

The P352AB controls are used with the P399 Electronic Pressure Transducers, which are available

in several pressure ranges, and provide a ratiometric analog signal (0.5 to 4.5 VDC), based on the sensed pressure.

**IMPORTANT:** The P352AB controls use an input signal from the P399 Electronic Pressure Transducer to determine pressure in psi (pounds per square inch). The P399 transducer uses a sealed-reference of one atmosphere to determine 0 psi. For more information on interpreting control pressure readings, refer to the *P399 Electronic Pressure Transducer Product/Technical Bulletin, LIT-125515.*

## Setpoint

Setpoint is defined as the pressure at which the relay de-energizes. The setpoint is adjustable between 0 to 100, 90 to 250, and 240 to 600 psi, depending on the model ordered. (See Table 1.)

**Table 1: Setpoint Adjustment Range**

P352AB Model No.	Setpoint Range
P352AB-2	0 to 100 psi
P352AB-3	90 to 250 psi
P352AB-4	240 to 600 psi

## Differential

Differential is defined as the difference in pressure between energization and de-energization of the output relay. The differential is adjustable between 2 to 50 and 10 to 100 psi, depending on the control model. (See Table 2.)

**Table 2: Differential Adjustment Range**

P352AB Model No.	Differential Range
P352AB-2	2 to 50 psi
P352AB-3	10 to 100 psi
P352AB-4	10 to 100 psi

## Direct/Reverse Acting Mode

The P352AB controls utilize jumpers (at Jumper Terminal J1) to select the operation mode. (See *Adjustments (P352AB Control)* section and Figure 3.)

When in **Direct Acting (DA) mode**, the relay de-energizes when the pressure drops below the setpoint. When the pressure rises above the setpoint *plus* the differential, the relay energizes and the “ON” LED illuminates.

When in **Reverse Acting (RA) mode**, the relay de-energizes when the sensed pressure rises above the setpoint. When the pressure drops below the setpoint *minus* the differential, the relay energizes and the “ON” LED illuminates.

Note: The P352AB controls are configured for DA mode at the factory.

Refer to Figure 5 for an example of a typical Direct Acting/Reverse Acting application.

## Dimensions

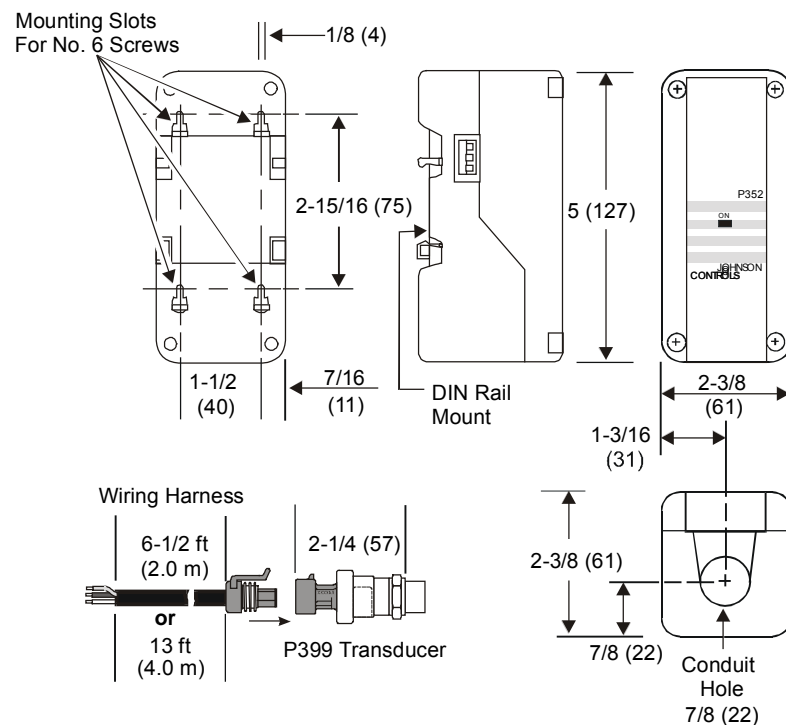

Figure 2: P352AB Control Dimensions, in. (mm)

## Mounting

The P352AB Electronic Pressure Control is housed in a compact NEMA 1 plastic enclosure designed for standard 35 mm DIN-rail mounting. Four key-slot mounting holes on the back of the control case are provided for surface mounting. (See Figure 2.)

Note: When mounting the P352AB control (or any System 350 Module) to rigid conduit, attach the hub to the conduit before securing the hub to the control enclosure.

## Adjustments (P352AB Control)

Perform the following steps to adjust the P352AB control settings. (See Figure 3.) Refer to Figure 5 for an example of the P352AB control in a typical Direct Acting/Reverse Acting application.



**WARNING: Risk of Electrical Shock.**

Disconnect the power supply before making electrical connections. Contact with components carrying hazardous voltage can cause electric shock and may result in severe personal injury or death.

**AVERTISSEMENT: Risque de décharge électrique.**

Débrancher l'alimentation avant de réaliser tout branchement électrique. Tout contact avec des composants conducteurs de tensions dangereuses risque d'entraîner une décharge électrique et de provoquer des blessures graves, voire mortelles.

1. Ensure all power to system is off.
2. Remove the P352AB control cover by loosening the four captive cover screws.

3. **Set the mode of operation** by positioning the jumpers (at Jumper Terminal J1) horizontally for Direct Acting or vertically for Reverse Acting.

Note: The P352AB controls are configured in the DA mode at the factory.

4. **Adjust the differential** using the potentiometer marked DIFF ADJUST to the desired setting. Clockwise rotation increases the differential.
5. **Adjust the setpoint** using the setpoint adjustment dial to the desired setting.

After power is applied to the control, a more accurate setting of the setpoint can be made by utilizing the D352A Pressure Display Module.

6. Replace the cover on the control and fasten in place with screws.
7. Restore power to system.

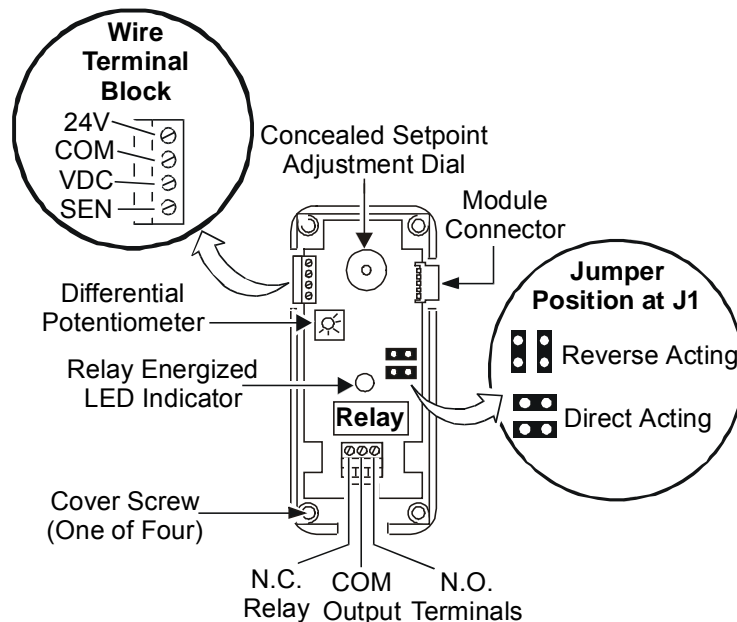

**Figure 3: Interior View and Typical Wiring of the P352AB Control**

## Add-On Modules

The Y350R Power Module, D352 Digital Pressure Display, and S352A Stage Modules snap together and plug into the P352AB Electronic Pressure Control via connectors on both sides of each add-on module.

### Y350R Power Module

The Y350R Power Module provides a convenient method of powering System 350 modules from a 120 or 240 VAC power source.

The Y350R Power Module can be plugged into the right side of the P352AB controls or any of the add-on modules. The Y350R Power Module is capable of providing power to a P352AB control, a D352 Display Module, and up to five S352A Stage Modules. (Refer to the *System 350™ Y350R Power Module Product/Technical Bulletin, LIT-930090*, for more information.)

### D352 Digital Pressure Display Module

The D352 Display Module receives power, sensor, and setpoint information from the P352AB control. A three digit Liquid Crystal Display (LCD) gives a continuous readout of the sensed pressure. Pushing the PRESS FOR SETPOINT button displays the setpoint of the adjoining P352AB control. The button must be pressed for approximately three seconds. (Refer to the *System 350™ Display Modules Product/Technical Bulletin, LIT-930070*, for more information.)

### S352A Pressure Stage Modules

The S352A Stage Modules receive power, setpoint, and sensor input from the P352AB controls. As many as five S352A Stage Modules can plug into the P352AB controls when powered by the Y350R Power Module. When powered by an external transformer, the P352AB controls can use up to nine S352A Stage Modules. (Refer to the *System 350™ S350A Temperature, S351A Humidity, and S352A Pressure Stage Modules Product/Technical Bulletin, LIT-930080*, for more information.)

Note: When using an external transformer, the Y65 Series or other 40 VA Class 2 transformers are recommended.

**IMPORTANT:** Verify that the jumpers are in the proper position before powering System 350 components. If the jumpers on the P352AB control or the S352A Stage Module are in the wrong position, the device will activate the relay in response to the opposite signal. The DA/RA relay will remain energized until the error is corrected.

## Adjustments (S352A Stage Module)

Perform the following steps to adjust the S352A stage module settings. (See Figure 4.) Refer to Figure 5 for an illustration of the S352A Stage Modules in a typical Direct Acting/Reverse Acting application.



**WARNING: Risk of Electrical Shock.**

Disconnect the power supply before making electrical connections. Contact with components carrying hazardous voltage can cause electric shock and may result in severe personal injury or death.

**AVERTISSEMENT: Risque de décharge électrique.**

Débrancher l'alimentation avant de réaliser tout branchement électrique. Tout contact avec des composants conducteurs de tensions dangereuses risque d'entraîner une décharge électrique et de provoquer des blessures graves, voire mortelles.

1. Ensure all power to system is off.  
Each stage module may be receiving separate power sources. Make sure all power sources to each stage module are off.
2. Remove the stage module cover by loosening the four captive cover screws.
3. **Set the mode of operation** by positioning the jumpers (at Jumper Terminal J2) horizontally for Direct Acting or vertically for Reverse Acting.
4. **Adjust the differential** using the potentiometer marked DIFF to the desired setting.
5. **Adjust the offset** using the potentiometer marked OFFSET to the desired pressure from the P352AB control setpoint at which the stage relay will de-energize (above setpoint with Direct Acting mode selected or below setpoint with Reverse Acting mode selected).

6. Replace the S352A stage module cover and tighten the captive cover screws.
7. Restore power to system.

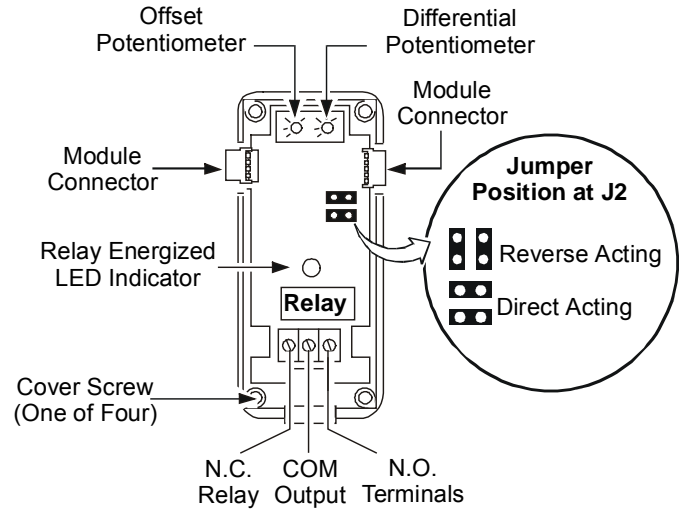

**Figure 4: Interior View and Typical Wiring of the S352A Stage Module**

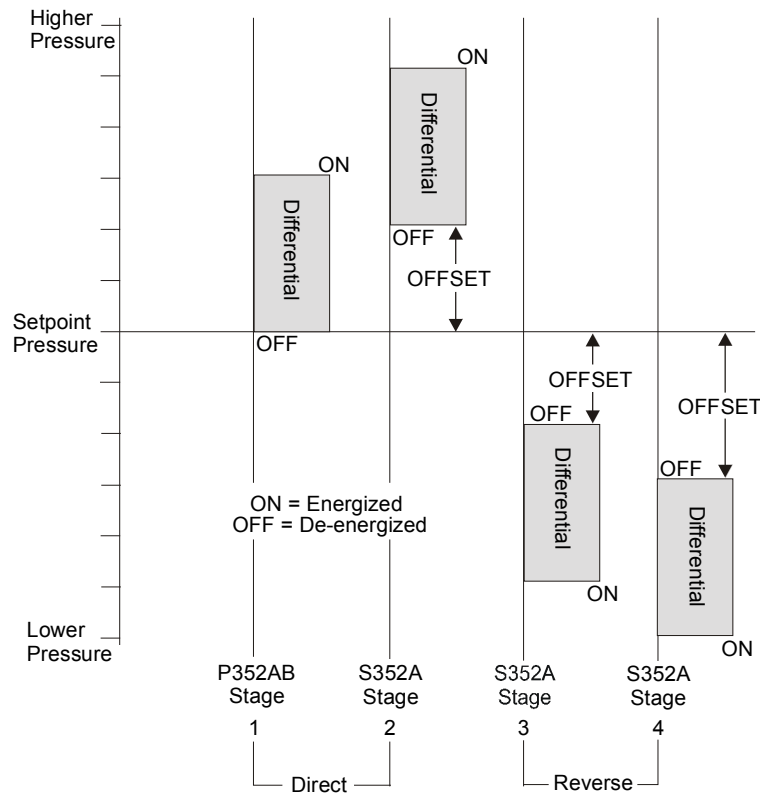

**Figure 5: Typical Direct Acting/Reverse Acting Application Using One P352AB Control and Three S352A Stage Modules**

# Wiring

Refer to the following guidelines and wiring diagrams for proper wiring and terminal designations. (See Table 3 and Figures 6 and 7.)



**WARNING: Risk of Electrical Shock.**

Disconnect the power supply before making electrical connections. Contact with components carrying hazardous voltage can cause electric shock and may result in severe personal injury or death.

**AVERTISSEMENT: Risque de décharge électrique.**

Débrancher l'alimentation avant de réaliser tout branchement électrique. Tout contact avec des composants conducteurs de tensions dangereuses risque d'entraîner une décharge électrique et de provoquer des blessures graves, voire mortelles.

**IMPORTANT:** Make all wiring connections in accordance with the National Electrical Code and all local regulations. Use copper conductors only. Do not exceed the control's electrical ratings.

## Transducer Wiring

The P352AB control supplies 5 VDC power to the P399 Electronic Pressure Transducer. The transducer is wired to three of the four connectors at the terminal block, located at the upper left of the circuit board. (See Figures 6 and 7.)

The transducer wiring harness has a shielded cable. Any additional length of cable should also be shielded cable. Connect the cable shield to the COM terminal on the P352AB control. Do not connect the other end of the cable shield.

**Table 3: Connecting the Transducer to the P352AB Control**

P352AB Control Terminal Designations	P399 Electronic Pressure Transducer Wire Colors
COM	Black (Common and Shield)
SEN	White (Output Signal)
VDC	Red (5 VDC Supply)

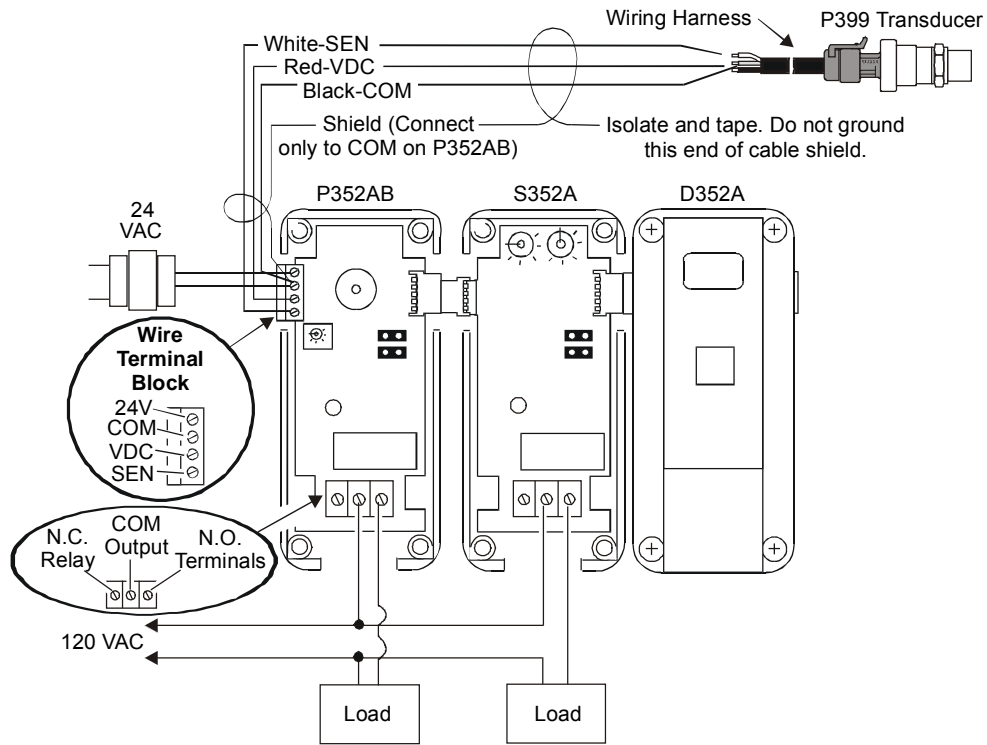

**Figure 6: System 350 Powered by an External Transformer Using 120 VAC Power Supply**

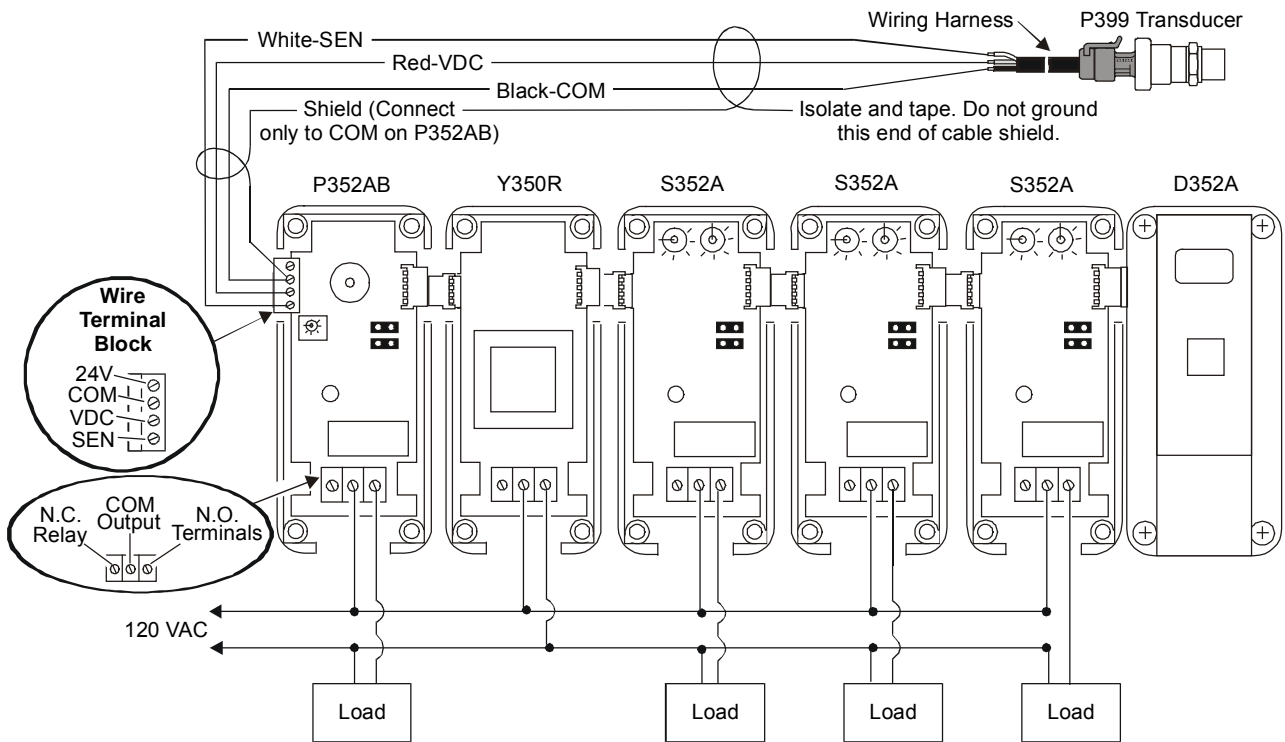

**Figure 7: System 350 Powered by a Y350R Power Module Using 120 VAC Power Supply**



## Checkout Procedure

Before applying power, make sure installation and wiring connections are according to job specifications. After necessary adjustments and electrical connections have been made, put the system in operation and observe at least three complete operating cycles before leaving the installation.

## Troubleshooting

If the System 350 control modules do not appear to function properly, verify that the proper mode (DA or RA) has been selected on each control module. Then perform the following procedures to determine the problem.

**IMPORTANT:** The control and the controlled equipment must be powered and operating at a stable pressure to perform many of the following procedures.

### Equipment Needed:

- A reliable pressure gauge connected near the transducer.
- A reliable and accurate Digital Voltmeter (DVM) capable of measuring AC voltage and DC voltages down to  $\pm 0.1$  VDC in the 0 to 10 VDC range.



### **WARNING: Risk of Electrical Shock.**

Disconnect all electric power sources from the System 350 control before opening the System 350 control cover. Contact with internal components carrying hazardous voltage can cause electric shock and may result in severe personal injury or death.

### **AVERTISSEMENT: Risque de décharge électrique.**

Déconnecter toutes les sources d'alimentation électrique de l' System 350 control avant de ouvrir le capot de l' System 350 control. Tout contact avec des composants internes conducteurs de tensions dangereuses risque d'entraîner une décharge électrique et de provoquer des blessures graves, voire mortelles.

### 1. Check for proper supply voltage to the Control.

- a. Before powering control and equipment, check that all of the wiring is correct and all of the connections are tight.
- b. Apply power to the control.

- c. With the DVM, check the voltage between the 24V and the COM terminals on the terminal block on the upper left side of the control.

**If an external 24 VAC transformer powers the control**, select AC volts on the DVM. The voltage must be between 20 and 30 VAC.

**If a Y350R Power Module powers the control**, select DC volts on the DVM. The voltage must be between 16 and 38 VDC.

- d. If the DVM reading is within the indicated voltage range, proceed to Step 2.
- e. If the DVM reading is **not** within the indicated voltage ranges, replace the external transformer or the Y350R Power Module, and recheck for proper supply voltage.

### 2. Check for proper supply voltage to the pressure transducer.

- a. Select DC volts on the DVM and measure the voltage ( $VDC_S$ ) between VDC and the COM terminals on the terminal block on the upper left side of the control.

The voltage must be 5.0 VDC ( $\pm 0.1$  VDC). If the voltage is in this range proceed to Step 3.

- b. If the voltage is out of this range, power down the controlled equipment and disconnect it from the control. Disconnect the transducer from the control. With the control powered, measure the voltage ( $VDC_S$ ) between VDC and the COM terminals on the terminal block on the upper left side of the control.

The voltage must be 5.0 VDC ( $\pm 0.1$  VDC). If the voltage is in this range, replace the transducer. If the voltage is out of range, replace the control.

### 3. Check pressure transducer for proper output signal voltage.

- a. Measure and record the voltage ( $V_o$ ) between the SEN and the COM terminals on the control terminal block.
- b. At the same time, observe and record the pressure reading ( $psi_T$ ) on the gauge.

- c. The transducer output signal voltage ( $V_O$ ) increases proportionally to an increase in the pressure at the transducer ( $psi_T$ ). Use the graph in Figure 8 to compare the measured signal voltage to the measured pressure or use the formula below to compare the voltage and pressure values.

$$psi_T = \left( V_O - \frac{VDC_S}{10} \right) \times \frac{1.25 \times P_{max}}{VDC_S}$$

$psi_T$  = Pressure measured at transducer

$V_O$  = Transducer output signal voltage (VDC)

$VDC_S$  = Supply voltage to the transducer (measured in step 2a).

$P_{max}$  = Transducer pressure range maximum

**Example:**

The measured pressure at the gauge is approximately 245 psi ( $psi_T$ ), the measured transducer output voltage is 2.5 VDC ( $V_O$ ), the measured supply voltage to the transducer is 5.03 VDC ( $VDC_S$ ), and the transducer's rated range is 0 to 500 psi ( $P_{max}$ ). Use the formula above to calculate the pressure you would expect from the measured voltage.

$$\left( 2.5 - \frac{5.03}{10} \right) \times \frac{1.25 \times 500}{5.03} = 248.1 \text{ psi}$$

Since the measured pressure of 245 psi ( $psi_T$ ) is close to the pressure calculated from the measured voltage of 248.1 psi, the transducer output voltage is considered within the desired range.

Note: Depending on the accuracy of the instrumentation used to measure the actual pressure at the transducer ( $psi_T$ ) and the transducer output voltage ( $V_O$ ), the actual and calculated pressure may not exactly agree.

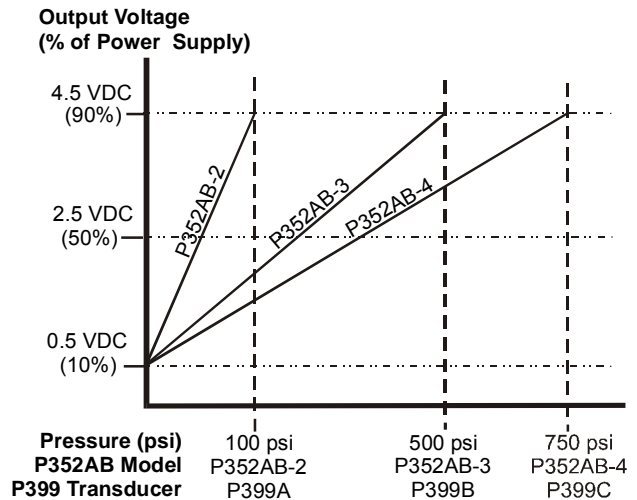

**Figure 8: Pressure vs. Output Voltage**

**4. Check the control for proper operation.**

Perform Steps 1-3 first.

Note: When the LED is lit, the N.O. contacts are closed.

- a. Determine and record if the control is in the DA or RA mode of operation. \_\_\_\_\_
- b. Determine the differential setting. \_\_\_\_\_
- c. Observe and record the system pressure at the gauge. \_\_\_\_\_
- d. **If the control is in the DA mode**, adjust the setpoint setting to a value lower than the observed gauge pressure. If the LED is not lit, turn the setpoint adjustment knob counterclockwise until the LED lights
- e. With the LED lit, slowly turn the setpoint adjustment knob clockwise (to increase the setpoint setting) until the LED goes off. Observe the gauge pressure, which should be the same as the setpoint setting when the LED goes off.
- f. Next turn the setpoint adjustment slowly counterclockwise until the LED lights again. Observe the gauge pressure, which should be equal to the differential setting plus the setpoint setting when the LED lit.

- g. **If the control is in the RA mode**, adjust the setpoint setting to a value higher than the observed gauge pressure. If the LED is not lit, turn the setpoint adjustment knob clockwise until the LED lights.
- h. With the LED lit, slowly turn the setpoint adjustment knob counterclockwise (to decrease the setpoint setting) until the LED goes off. Observe the gauge pressure, which should be the same as the setpoint setting when the LED went off.
- i. Next turn the setpoint adjustment slowly clockwise until the LED lights again. Observe the gauge pressure, which should be equal to the setpoint setting minus the differential setting.

**5. Check the stage modules for proper operation.**

Perform Steps 1-4 first.

If stage modules are not used, proceed to Step 6.

- a. Determine and record if the stage module is in the DA or RA mode of operation. \_\_\_\_\_
- b. Determine the differential setting. \_\_\_\_\_
- c. Observe and record the offset setting. \_\_\_\_\_
- d. Observe and record the system pressure at the gauge. \_\_\_\_\_

- e. Use the procedure outlined in Steps 4a-4i to determine if the stage module is operating properly. Use Table 4 to determine what the On and Off setpoint pressure values are for each module.
- f. If a stage module LED and relay do not perform as expected, adjust the differential and offset potentiometers to their minimum value and repeat the previous checks.
- g. If a stage module still does not perform properly, replace the stage module.

**6. Check the display module for proper operation.**

If there is no display module in the system, skip this step.

Perform Steps 1-5 first.

- a. Check the gauge pressure (psi) at the transducer.
- b. If the display module does **not** display the (approximate) pressure measured at the gauge, replace the display module.
- c. Pressing the button on the display module should display the current setpoint setting.

If the displayed setpoint is out of the control's setpoint pressure range (check scale-plate at the setpoint knob for control's pressure range), replace the control.

**Table 4: S352A Stage Module Relay Troubleshooting**

Operating Mode	LED	N.O. Contact Position	Setpoint Setting Equals Approximately...
Direct Acting (DA)	On	Closed	(psi reading) - offset - differential
Direct Acting (DA)	Off	Open	(psi reading) - offset
Reverse Acting (RA)	On	Closed	(psi reading) + offset + differential
Reverse Acting (RA)	Off	Open	(psi reading) + offset

## Repairs and Replacement

Field repairs or calibration must not be made. Replacement controls and pressure transducers are available through your local Johnson Controls representative.

## Ordering Information

**Table 5: System 350 Products**

Item	Product Code Number	Description
<b>P352AB Electronic Pressure Control Series</b>	P352AB-2C*	SPDT Relay with LED Indication Setpoint Adjustment Range: 0-100 psi Differential Adjustment Range: 2-50 psi
	P352AB-3C*	SPDT Relay with LED indication Setpoint Adjustment Range: 90-250 psi Differential Adjustment Range: 10-100 psi
	P352AB-4C*	SPDT Relay with LED indication Setpoint Adjustment Range: 240-600 psi Differential Adjustment Range: 10 to 100 psi
<b>Electronic Pressure Transducers for the P352AB-2</b>	P399AAA-1C* P399AAC-1C*	0 to 100 psis; 1/8 in. NPT male pressure connection 0 to 100 psis; 1/4 in. SAE female flare pressure connection
<b>Electronic Pressure Transducers for the P352AB-3</b>	P399BAA-1C* P399BAC-1C*	0 to 500 psis; 1/8 in. NPT male pressure connection 0 to 500 psis; 1/4 in. SAE female flare pressure connection
<b>Electronic Pressure Transducers for the P352AB-4</b>	P399CAA-1C* P399CAC-1C*	0 to 750 psis; 1/8 in. NPT male pressure connection 0 to 750 psis; 1/4 in. SAE female flare pressure connection
<b>Wiring Harness</b>	WHA-P399-400C* WHA-P399-200C*	13.1 ft (4.0 m) length 6.6 ft (2.0 m) length
<b>Display Module</b>	D352AA-2C	Digital Pressure Display Module
<b>Stage Module</b>	S352AA-2C	Pressure Stage Module Used with P399 Pressure Transducer
<b>Power Module</b>	Y350R-1C	Rectified 24 VAC from 120/240 VAC Source

\* Electronic Pressure Transducer and Wiring Harness must be ordered separately.

**Table 6: System 350 Accessories**

Item	Product Code Number	Description
<b>Conduit Adaptor</b>	ADP11A-600R	1/2 in. snap-fit EMT conduit adaptor (box of 10)
<b>DIN Rail Sections</b>	BKT287-1R	12 in. (0.3 m) long
	BKT287-2R	39-1/3 in. (1.0 m) long
<b>DIN Rail End Clamp</b>	PLT344-1R	Consists of two end clamps
<b>Cables for Remote Mounting of D352 Display Module</b>	WHA29A-600R*	3 ft (0.9 m)
	WHA29A-603R	25 ft (7.6 m)
	WHA29A-604R	50 ft (15.2 m)

\* WHA29A-600R may be used to link S352A Stage Modules together.

# Specifications

<b>Product</b>	P352AB Electronic Pressure Control Series	
<b>Pressure Setpoint Range</b>	P352AB-2: 0 to 100 psi P352AB-3: 90 to 250 psi P352AB-4: 240 to 600 psi	
<b>Differential Range</b>	P352AB-2: 2 to 50 psi P352AB-3: 10 to 100 psi P352AB-4: 10 to 100 psi	
<b>Supply Voltage*</b>	Y350R Power Module or Class 2 Transformer, 20-30 VAC; 50/60 Hz	
<b>DC Power Supply Output</b>	5 VDC to power the P399 Electronic Pressure Transducer	
<b>Output Relay</b>	SPDT Enclosed Relay	
<b>Power Requirement</b>	1.8 VA maximum	
<b>Input Signal</b>	0.5 to 4.5 VDC Ratiometric Signal from P399 Electronic Pressure Transducer	
<b>Electrical Ratings</b>	Full Load Amperes: 9.8 (120 VAC)	4.9 (208/240 VAC)
	Locked Rotor Amperes: 58.8 (120 VAC)	29.4 (208/240 VAC)
	Non-Inductive Amperes: 10 at 24/240 VAC	
	Pilot Duty: 125 VA at 24/240 VAC	
<b>Ambient Temperature</b>	Operating: -30 to 150°F (-34 to 66°C) Shipping: -40 to 185°F (-40 to 85°C)	
<b>Ambient Humidity</b>	0 to 95% RH (Non-condensing)	
<b>Material</b>	Case, Cover: NEMA 1 High Impact Thermoplastic	
<b>Agency Listing</b>	UL Listed, CCN XAPX, File E27734 UL Listed for Canada, CCN XAPX7, File E27734	

\* Only one voltage source may be used.

#### Add-on Modules:

<b>S352A</b>	Relay Contacts:	SPDT, 10 Amperes Non-inductive, 1/2 hp 120/240 VAC
	DIFF and OFFSET:	2 to 50 psi Differential; 2 to 50 psi Offset
<b>Y350R</b>	Input Voltage:	120/240 VAC, 50/60 Hz
<b>D352</b>	Display Range:	0 to 750 psi

The performance specifications are nominal and conform to acceptable industry standards. For application at conditions beyond these specifications, consult Johnson Controls/Penn Application Engineering at (414) 274-5535. Johnson Controls, Inc. shall not be liable for damages resulting from misapplication or misuse of its products.



**Building Efficiency**  
507 E. Michigan Street, Milwaukee, WI 53202

© Johnson Controls and PENN are registered trademarks of Johnson Controls, Inc. in the United States of America and/or other countries. All other trademarks used herein are the property of their respective owners. © Copyright 2014 by Johnson Controls, Inc. All rights reserved.